

Technical Manual

**Aviation Unit and Intermediate  
Troubleshooting Manual**

for

**ARMY Model  
AH-64A HELICOPTER  
(NSN 1520-01-106-9519) (EIC: RHA)**

CHAPTER 12 UTILITY SYSTEM

CHAPTER 13 ENVIRONMENTAL CONTROL SYSTEM

CHAPTER 14 HOISTS AND WINCHES (Not Applicable)

CHAPTER 15 AUXILIARY POWER UNIT

CHAPTER 16 MISSION EQUIPMENT

**SUPERSEDURE NOTICE:** This manual supersedes TM 55-1520-238-T-3, dated 15 DECEMBER 1985, including all changes.

**DISTRIBUTION STATEMENT A:** Approved for public release; distribution is unlimited.

---

**HEADQUARTERS, DEPARTMENT OF THE ARMY  
30 APRIL 1992**



The **WARNINGS** on these pages are to notify you of operating or maintenance procedures, practices or conditions, which, if not strictly observed, could result in long term health hazards, injury or death to personnel. If injury occurs, seek medical aid immediately. These **WARNINGS** must be obeyed by all personnel using this volume.

**WARNING****NOISE**

Personnel in the area of jet engine operation will wear approved ear protection to protect their hearing.

**WARNING****ELECTRICAL POWER**

- Voltages used may cause arcing. Remove rings, watches, and other jewelry which may cause a shock/burn hazard.
- Voltages used may cause severe shock or death on contact. Use caution to avoid contact with energized components.
- Turn off power before detaching or attaching wires and connectors. Failure to do so could result in death or serious injury.
- When opening a circuit breaker during system checks, tag circuit breaker to prevent unforeseen closing, which may cause injury or death to personnel.
- For artificial respiration, refer to FM 21-11.

**WARNING****FIRE EXTINGUISHING AGENT**

- Fire extinguishing agent can burn eyes and skin or cause oxygen deficiency in a closed environment. Wear safety glasses whenever working around fire bottles. In case of accidental discharge of fire extinguishing agent, wash exposed skin with fresh water and ventilate if discharge occurs in a closed environment. If exposure occurs, seek medical aid immediately.

When using a fire extinguisher in a enclosed area, wear a respirator. If fire extinguisher is discharged, ventilate space as soon as possible. Serious personal injury could occur if vapors are inhaled.



CHANGE }  
NO. 12 }

HEADQUARTERS  
DEPARTMENT OF THE ARMY  
WASHINGTON, D.C., 27 February 2004

TECHNICAL MANUAL  
AVIATION UNIT AND INTERMEDIATE  
TROUBLESHOOTING MANUAL  
FOR  
ARMY MODEL  
AH-64A HELICOPTER  
NSN: (1520-01-106-9519) EIC: (RHA)

DISTRIBUTION STATEMENT A: Approved for public release; distribution is unlimited.

**OZONE DEPLETING CHEMICAL INFORMATION:**

This document has been reviewed for the presence of Class I Ozone depleting chemicals. As of Change 8 dated 19 December 1997, all references to Class I Ozone depleting chemicals have been removed from this document by substitution with chemicals that do not cause atmospheric Ozone depletion.

TM 1-1520-238-T-8, 30 April 1992, is changed as follows:

1. Remove and insert pages as indicated below. New or changed text material is indicated by a vertical bar in the margin. An illustration change is indicated by a miniature pointing hand.

Remove pages	Insert pages
A trough C/(D blank)	A trough C/(D blank)
15-1 and 15-2	15-1 and 15-2
- - - -	15-36.1 through 15-36.8
15-37 and 15-38	15-37 and 15-38

2. Retain this sheet in front of manual for reference purposes.

By Order of the Secretary of the Army:

Official:

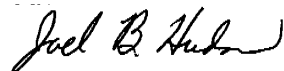

**JOEL B. HUDSON**  
*Administrative Assistant to the  
Secretary of the Army*  
0405501

**PETER J. SCHOOMAKER**  
*General, United States Army  
Chief of Staff*

**DISTRIBUTION:** To be distributed in accordance with Initial Distribution No. (IDN) 313122 requirements for TM 1-1520-238-T-8.



CHANGE }  
NO. 11 }

HEADQUARTERS  
DEPARTMENT OF THE ARMY  
WASHINGTON, D.C., 15 February 2002

TECHNICAL MANUAL  
AVIATION UNIT AND INTERMEDIATE  
TROUBLESHOOTING MANUAL  
FOR  
ARMY MODEL  
AH-64A HELICOPTER  
NSN: (1520-01-106-9519) EIC: (RHA)

DISTRIBUTION STATEMENT A: Approved for public release; distribution is unlimited.

**OZONE DEPLETING CHEMICAL INFORMATION:**

This document has been reviewed for the presence of Class I Ozone depleting chemicals. As of Change 8 dated 19 December 1997, all references to Class I Ozone depleting chemicals have been removed from this document by substitution with chemicals that do not cause atmospheric Ozone depletion.

TM 1-1520-238-T-8, 30 April 1992, is changed as follows:

1. Remove and insert pages as indicated below. New or changed text material is indicated by a vertical bar in the margin. An illustration change is indicated by a miniature pointing hand.

Remove pages	Insert pages
A trough C/(D blank)	A trough C/(D blank)
i and ii	i and ii
12-211 and 12-212	12-211 and 12-212
15-27 and 15-28	15-27 and 15-28
15-37 and 15-38	15-37 and 15-38
15-63 and 15-64	15-63 and 15-64
16-61 and 16-62	16-61 and 16-62

2. Retain this sheet in front of manual for reference purposes.

By Order of the Secretary of the Army:

Official:

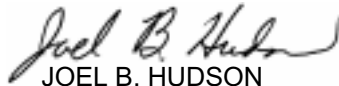

JOEL B. HUDSON  
Administrative Assistant to the  
Secretary of the Army

0201613

ERIC K. SHINSEKI  
General, United States Army  
Chief of Staff

**DISTRIBUTION:** To be distributed in accordance with Initial Distribution No. (IDN) 313122 requirements for TM 1-1520-238-T-8.





CHANGE }  
NO. 10 }

HEADQUARTERS  
DEPARTMENT OF THE ARMY  
WASHINGTON, D.C., 25 May 2001

TECHNICAL MANUAL  
AVIATION UNIT AND INTERMEDIATE  
TROUBLESHOOTING MANUAL  
FOR  
ARMY MODEL  
AH-64A HELICOPTER  
NSN: (1520-01-106-9519) EIC: (RHA)

DISTRIBUTION STATEMENT A: Approved for public release; distribution is unlimited.

TM 1-1520-238-T-8, 30 April 1992, is changed as follows:

1. Remove and insert pages as indicated below. New or changed text material is indicated by a vertical bar in the margin. An illustration change is indicated by a miniature pointing hand.

Remove pages

Insert pages

-----  
12-201 through 12-204

A and B  
12-201 through 12-204

2. Retain this sheet in front of manual for reference purposes.

By Order of the Secretary of the Army:

Official:



JOEL B. HUDSON  
*Administrative Assistant to the  
Secretary of the Army*

0110904

ERIC K. SHINSEKI  
*General, United States Army  
Chief of Staff*

**DISTRIBUTION:**

To be distributed in accordance with Initial Distribution No. (IDN 313122) requirements for TM 1-1520-238-T-8.



CHANGE }  
NO. 9 }

HEADQUARTERS  
DEPARTMENT OF THE ARMY  
WASHINGTON, D.C., 3 May 2000

TECHNICAL MANUAL  
AVIATION UNIT AND INTERMEDIATE  
TROUBLESHOOTING MANUAL  
FOR  
ARMY MODEL  
AH-64A HELICOPTER  
NSN: (1520-01-106-9519) EIC: (RHA)

TM 1-1520-238-T-8, 30 April 1992, is changed as follows:

1. Remove and insert pages as indicated below. New or changed text material is indicated by a vertical bar in the margin. An illustration change is indicated by a miniature pointing hand.

Remove pages

-----  
12-153 through 12-164  
Glossary-1 and Glossary-2  
Index-9 and Index-10  
Index-13 and Index-14

Insert pages

A through C/(D blank)  
12-153 through 12-164  
Glossary-1 and Glossary-2  
Index-9 and Index-10  
Index-13 and Index-14

2. Retain this sheet in front of manual for reference purposes.

By Order of the Secretary of the Army:

Official:



JOEL B. HUDSON  
*Administrative Assistant to the  
Secretary of the Army*

0007003

ERIC K. SHINSEKI  
*General, United States Army  
Chief of Staff*

**DISTRIBUTION:**

To be distributed in accordance with Initial Distribution No. (IDN 313122) requirements for TM 1-1520-238-T-8.



CHANGE }  
NO. 8 }

HEADQUARTERS  
DEPARTMENT OF THE ARMY  
WASHINGTON, D.C., 19 December 1997

TECHNICAL MANUAL  
AVIATION UNIT AND INTERMEDIATE  
TROUBLESHOOTING MANUAL  
FOR  
ARMY MODEL  
AH-64A HELICOPTER  
NSN: (1520-01-106-9519) EIC: (RHA)

TM 1-1520-238-T-8, 30 April 1992, is changed as follows:

1. Remove and insert pages as indicated below. New or changed text material is indicated by a vertical bar in the margin. An illustration change is indicated by a miniature pointing hand.

Remove pages

a/b(blank)  
i and ii  
v and vi  
12-3 and 12-4  
12-103 and 12-104  
12-107 and 12-108  
12-113 through 12-116  
12-119 and 12-120  
12-131 and 12-132  
12-135 and 12-136  
12-193 and 12-194  
12-313 and 12-314  
13-29 through 13-34  
15-47 and 15-48  
15-53 and 15-54

Insert pages

a/b(blank)  
i and ii  
v and vi  
12-3 and 12-4  
12-103 and 12-104  
12-107 and 12-108  
12-113 through 12-116  
12-119 and 12-120  
12-131 and 12-132  
12-135 and 12-136  
12-193 and 12-194  
12-313 and 12-314  
13-29 through 13-34  
15-47 and 15-48  
15-53 and 15-54

2. Retain this sheet in front of manual for reference purposes.

By Order of the Secretary of the Army:

Official:

  
JOEL B. HUDSON

Administrative Assistant to the  
Secretary of the Army  
04572

DENNIS J. REIMER  
General, United States Army  
Chief of Staff

**DISTRIBUTION:**

To be distributed in accordance with Initial Distribution No. (IDN) 313122 requirements for TM 1-1520-238-T-8.



CHANGE }  
NO. 7 }

HEADQUARTERS  
DEPARTMENT OF THE ARMY  
WASHINGTON, D.C., 30 September 1996

TECHNICAL MANUAL  
AVIATION UNIT AND INTERMEDIATE  
TROUBLESHOOTING MANUAL  
FOR  
ARMY MODEL  
AH-64A HELICOPTER  
NSN: (1520-01-106-9519) EIC: (RHA)

TM 1-1520-238-T-8, 30 April 1992, is changed as follows:

1. Remove and insert pages as indicated below. New or changed text material is indicated by a vertical bar in the margin. An illustration change is indicated by a miniature pointing hand.

Remove pages

i and ii  
v and vi  
----  
12-85 and 12-86  
12-121 through 12-124  
12-169 and 12-170  
12-179 and 12-180  
12-183 and 12-184  
12-285 and 12-286  
13-13 and 13-14  
13-39 and 13-40  
15-35 and 15-36  
15-39 and 15-40  
16-27 and 16-28  
16-55 and 16-56

Insert pages

i and ii  
v and vi  
vii/(viii blank)  
12-85 and 12-86  
12-121 through 12-124  
12-169 and 12-170  
12-179 and 12-180  
12-183 and 12-184  
12-285 and 12-286  
13-13 and 13-14  
13-39 and 13-40  
15-35 and 15-36  
15-39 and 15-40  
16-27 and 16-28  
16-55 and 16-56

2. Retain this sheet in front of manual for reference purposes.

By Order of the Secretary of the Army:

Official:

  
JOEL B. HUDSON

*Administrative Assistant to the  
Secretary of the Army*

02541

DENNIS J. REIMER  
*General, United States Army  
Chief of Staff*

**DISTRIBUTION:**

To be distributed in accordance with DA Form 12-31-E, block no. 3122, requirements for TM 1-1520-238-T-8.





CHANGE }  
NO. 6 }

HEADQUARTERS  
DEPARTMENT OF THE ARMY  
WASHINGTON, D.C., 1 February 1996

AVIATION UNIT AND INTERMEDIATE  
TROUBLESHOOTING MANUAL  
FOR  
ARMY MODEL  
AH-64A HELICOPTER  
NSN (1520-01-106-9519) EIC: (RHA)

DISTRIBUTION STATEMENT A: Approved for public release; distribution is unlimited.

TM 1-1520-238-T-8, 30 April 1992, is changed as follows:

1. Remove and insert pages as indicated below. New or changed text material is indicated by a vertical bar in the margin. An illustration change is indicated by a miniature pointing hand.

Remove pages

v and vi  
12-91 and 12-92  
12-113 through 12-116  
12-181 and 12-182  
12-203 through 12-206  
12-215 and 12-216  
15-9 and 15-10  
15-79 and 15-80  
16-57 and 16-58  
Index-1 and Index-2  
Index-7 and Index-8

Insert pages

v and vi  
12-91 and 12-92  
12-113 through 12-116  
12-181 and 12-182  
12-203 through 12-206  
12-215 and 12-216  
15-9 and 15-10  
15-79 and 15-80  
16-57 and 16-58  
Index-1 and Index-2  
Index-7 and Index-8

2. Retain this sheet in front of manual for reference purposes.

By Order of the Secretary of the Army:

Official:

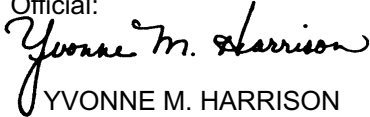

YVONNE M. HARRISON  
*Administrative Assistant to the  
Secretary of the Army*

01264

DENNIS. J. REIMER  
*General, United States Army  
Chief of Staff*

**DISTRIBUTION:**

To be distributed in accordance with DA Form 12-31-E, block no. 3122, requirements for TM 1-1520-238-T-8.

**URGENT**

TM 1-1520-238-T-8  
C 5

CHANGE }  
NO. 5 }

HEADQUARTERS  
DEPARTMENT OF THE ARMY  
WASHINGTON, D.C., 2 AUGUST 1995

AVIATION UNIT AND INTERMEDIATE  
TROUBLESHOOTING MANUAL  
FOR  
ARMY MODEL  
AH-64A HELICOPTER  
NSN: (1520-01-106-9519) EIC: (RHA)

**DISTRIBUTION STATEMENT A: Approved for public release; distribution is unlimited.**

TM 1-1520-238-T-8, 30 April 1992, is changed as follows:

1. Remove and insert pages as indicated below. New or changed text material is indicated by a vertical bar in the margin. An illustration change is indicated by a miniature pointing hand.

Remove pages

Insert pages

12-319 and 12-320

12-319 and 12-320

2. Retain this sheet in front of manual for reference purposes.

By Order of the Secretary of the Army:

Official:



JOEL B. HUDSON

*Administrative Assistant to the  
Secretary of the Army*

00518

DENNIS J. REIMER  
*General, United States Army  
Chief of Staff*

**DISTRIBUTION:** To be distributed in accordance with DA Form 12-31-E, block no. 3122, requirements for TM 1-1520-238-T-8.

**URGENT**



CHANGE }  
NO. 4 }

HEADQUARTERS  
DEPARTMENT OF THE ARMY  
WASHINGTON, D.C., 28 December 1994

AVIATION UNIT AND INTERMEDIATE  
TROUBLESHOOTING MANUAL  
FOR  
ARMY MODEL  
AH-64A HELICOPTER  
NSN (1520-01-106-9519) EIC: (RHA)

DISTRIBUTION STATEMENT A: Approved for public release; distribution is unlimited.

TM 1-1520-238-T-8, 30 April 1992, is changed as follows:

1. Remove and insert pages as indicated below. New or changed text material is indicated by a vertical bar in the margin. An illustration change is indicated by a miniature pointing hand.

Remove pages	Insert pages
12-21 and 12-22	12-21 and 12-22
12-27 through 12-30	12-27 through 12-30
12-39 and 12-40	12-39 and 12-40
12-121 and 12-122	12-121 and 12-122
12-125 through 12-130	12-125 through 12-130
12-313 through 12-320	12-313 through 12-320
- - - -	12-320.1 and 12-320.2
12-321 and 12-322	(12-321 blank)/12-322
- - - -	12-334.1/(12-334.2 blank)
13-1 and 13-2	13-1 and 13-2
13-29 and 13-30	13-29 and 13-30
13-51 and 13-52	13-51 and 13-52
13-55 and 13-56	13-55 and 13-56
15-37 and 15-38	15-37 and 15-38
15-41 and 15-42	15-41 and 15-42
15-45 and 15-46	15-45 and 15-46
15-55 and 15-56	15-55 and 15-56

2. Retain this sheet in front of manual for reference purposes.

By Order of the Secretary of the Army:

Official:

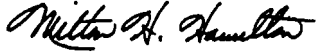

MILTON H. HAMILTON  
*Administrative Assistant to the  
Secretary of the Army*  
07877

GORDON R. SULLIVAN  
*General, United States Army  
Chief of Staff*

**DISTRIBUTION:**

To be distributed in accordance with DA Form 12-31-E, block no. 3122, requirements for  
TM 1-1520-238-T-8.

CHANGE }  
NO. 3 }

HEADQUARTERS  
DEPARTMENT OF THE ARMY  
WASHINGTON, D.C., 31 August 1993

Aviation Unit and Intermediate  
Troubleshooting Manual  
For  
ARMY MODEL  
AH-64A HELICOPTER  
NSN: (1520-01-106-9519) EIC: (RHA)

DISTRIBUTION STATEMENT A: Approved for public release; distribution is unlimited.

TM 1-1520-238-T-8, 30 April 1992, is changed as follows:

1. Remove and insert pages as indicated below. New or changed text material is indicated by a vertical bar in the margin. An illustration change is indicated by a miniature pointing hand.

Remove pages

iii through vi  
12-21 and 12-22  
12-27 thru 12-36  
12-229 and 12-230  
15-37 and 15-38  
15-41 and 15-42

Insert pages

iii through vi  
12-21 and 12-22  
12-27 thru 12-36  
12-229 and 12-230  
15-37 and 15-38  
15-41 and 15-42

2. Retain this sheet in front of manual for reference purposes.

By Order of the Secretary of the Army:

Official:

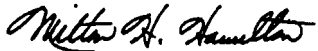

MILTON H. HAMILTON  
*Administrative Assistant to the  
Secretary of the Army*  
05323

GORDON R. SULLIVAN  
*General, United States Army  
Chief of Staff*

**DISTRIBUTION:**

To be distributed in accordance with DA Form 12-31-E, block no. 3122, requirements for  
TM 1-1520-238-T-8.





CHANGE }  
NO. 2 }

HEADQUARTERS  
DEPARTMENT OF THE ARMY  
WASHINGTON, D.C., 15 JANUARY 1993

Aviation Unit and Intermediate  
Troubleshooting Manual

AH-64A HELICOPTER

TM 1-1520-238-T-8, 30 April 1992, is changed as follows:

1. Remove and insert pages as indicated below. New or changed text material is indicated by a vertical bar in the margin. An illustration change is indicated by a miniature pointing hand.

Remove pages

iii through vi  
12-97 and 12-98  
12-101 and 12-102  
12-127 and 12-128  
12-173 and 12-174  
12-187 and 12-188  
12-191 through 12-194  
12-229 through 12-232  
12-255 through 12-258  
12-295 through 12-300  
12-323 and 12-324  
12-327 and 12-328  
13-35 through 13-42  
15-27 and 15-28  
15-35 through 15-38  
15-41 and 15-42  
15-45 and 15-46  
16-39 and 16-40

Insert pages

iii through vi  
12-97 and 12-98  
12-101 and 12-102  
12-127 and 12-128  
12-173 and 12-174  
12-187 and 12-188  
12-191 through 12-194  
12-229 through 12-232  
12-255 through 12-258  
12-295 through 12-300  
12-323 and 12-324  
12-327 and 12-328  
13-35 through 13-42  
15-27 and 15-28  
15-35 through 15-38  
15-41 and 15-42  
15-45 and 15-46  
16-39 and 16-40

2. Retain this sheet in front of manual for reference purposes.

By Order of the Secretary of the Army:

Official:

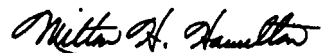

MILTON H. HAMILTON  
*Administrative Assistant to the  
Secretary of the Army*

03322

GORDON R. SULLIVAN  
*General, United States Army  
Chief of Staff*

**DISTRIBUTION STATEMENT A: Approved for public release; distribution is unlimited.**

**DISTRIBUTION:**

To be distributed in accordance with DA Form 12-31-E, block no. 3122, requirements for TM 1-1520-238-T-8.

CHANGE }  
NO. 1 }

HEADQUARTERS  
DEPARTMENT OF THE ARMY  
WASHINGTON, D.C., 15 December 1992

Aviation Unit and Intermediate  
Troubleshooting Manual

For

ARMY MODEL  
AH-64A HELICOPTER

NSN: (1520-01-106-9519) EIC: (RHA)

TM 1-1520-238-T-8, 30 April 1992, is changed as follows:

1. Remove and insert pages as indicated below. New or changed text material is indicated by a vertical bar in the margin. An illustration change is indicated by a miniature pointing hand.

Remove pages

Insert pages

16-1 and 16-2  
Appendix-1 and Appendix-2

16-1 and 16-2  
Appendix-1 and Appendix-2

2. Retain this sheet in front of manual for reference purposes.

By Order of the Secretary of the Army:

Official:

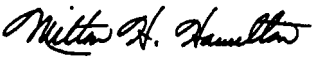
  
MILTON H. HAMILTON  
Administrative Assistant to the  
Secretary of the Army  
03149

GORDON R. SULLIVAN  
General, United States Army  
Chief of Staff

**DISTRIBUTION:** To be distributed in accordance with DA Form 12-31-E, block no. 3122, requirements for TM 1-1520-238-T-8.

DISTRIBUTION STATEMENT A: Approved for public release; distribution is unlimited.



INSERT LATEST CHANGED PAGES: DESTROY SUPERSEDED PAGES.

**LIST OF EFFECTIVE PAGES**

**NOTE:** The portion of the text affected by the changes is indicated by a vertical line in the outer margins of the page. Changes to illustrations are indicated by miniature pointing hands. Changes to wiring diagrams are indicated by shaded areas.

Date of issue for original and change pages are:

Original . . . . . 0 . . . . . 30 April 1992	Change . . . . . 7 . . . . . 30 September 1996
Change . . . . . 1 . . . . . 15 December 1992	Change . . . . . 8 . . . . . 19 December 1997
Change . . . . . 2 . . . . . 15 January 1993	Change . . . . . 9 . . . . . 3 May 2000
Change . . . . . 3 . . . . . 31 August 1993	Change . . . . . 10 . . . . . 25 May 2001
Change . . . . . 4 . . . . . 28 December 1994	Change . . . . . 11 . . . . . 15 September 2002
Change . . . . . 5 . . . . . 2 August 1995	Change . . . . . 12 . . . . . 27 February 2004
Change . . . . . 6 . . . . . 1 February 1996	

**TOTAL NUMBER OF PAGES IN THIS PUBLICATION IS 658, CONSISTING OF THE FOLLOWING:**

<b>Page No.</b>	<b>*Change No.</b>	<b>Page No.</b>	<b>*Change No.</b>
Cover . . . . .	0	12-113 - 12-114 . . . . .	8
Blank . . . . .	0	12-115 . . . . .	6
a . . . . .	8	12-116 . . . . .	8
b Blank . . . . .	8	12-117 - 12-119 . . . . .	0
A - C . . . . .	11	12-120 . . . . .	8
D Blank . . . . .	11	12-121 . . . . .	0
i . . . . .	11	12-122 - 12-123 . . . . .	7
ii - iii . . . . .	0	12-124 . . . . .	0
iv . . . . .	3	12-125 . . . . .	4
v . . . . .	7	12-126 . . . . .	0
vi . . . . .	8	12-127 . . . . .	4
vii . . . . .	7	12-128 . . . . .	0
viii Blank . . . . .	7	12-129 . . . . .	4
12-1 - 12-3 . . . . .	0	12-130 - 12-131 . . . . .	0
12-4 . . . . .	8	12-132 . . . . .	8
12-5 - 12-21 . . . . .	0	12-133 - 12-134 . . . . .	0
12-22 . . . . .	4	12-135 . . . . .	8
12-23 - 12-27 . . . . .	0	12-136 - 12-153 . . . . .	0
12-28 - 12-29 . . . . .	4	12-154 - 12-155 . . . . .	9
12-30 . . . . .	0	12-156 - 12-157 . . . . .	0
12-31 . . . . .	3	12-158 - 12-159 . . . . .	9
12-32 . . . . .	0	12-160 . . . . .	0
12-33 . . . . .	3	12-161 . . . . .	9
12-34 . . . . .	0	12-162 . . . . .	0
12-35 - 12-36 . . . . .	3	12-163 . . . . .	9
12-37 - 12-38 . . . . .	0	12-164 - 12-168 . . . . .	0
12-39 . . . . .	4	12-169 . . . . .	7
12-40 - 12-85 . . . . .	0	12-170 - 12-173 . . . . .	0
12-86 . . . . .	7	12-174 . . . . .	2
12-87 - 12-91 . . . . .	0	12-175 - 12-179 . . . . .	0
12-92 . . . . .	6	12-180 . . . . .	7
12-93 - 12-96 . . . . .	0	12-181 - 12-182 . . . . .	6
12-97 . . . . .	2	12-183 . . . . .	7
12-98 - 12-100 . . . . .	0	12-184 - 12-187 . . . . .	0
12-101 . . . . .	2	12-188 . . . . .	2
12-102 - 12-103 . . . . .	0	12-189 - 12-190 . . . . .	0
12-104 . . . . .	8	12-191 - 12-193 . . . . .	2
12-105 - 12-106 . . . . .	0	12-194 . . . . .	8
12-107 - 12-108 . . . . .	8	12-195 - 12-200 . . . . .	0
12-109 - 12-112 . . . . .	0	12-201 . . . . .	10

\*Zero in this column indicates an original page.

INSERT LATEST CHANGED PAGES: DESTROY SUPERSEDED PAGES.

**LIST OF EFFECTIVE PAGES**

Page No.	*Change No.	Page No.	*Change No.
12-202	0	13-57 - 13-63	0
12-203 - 12-204	10	13-64 Blank	0
12-205 - 12-206	6	14-1	0
12-207 - 12-210	0	14-2 Blank	0
12-211 - 12-212	11	15-1	12
12-213 - 12-215	0	15-2 - 15-8	0
12-216	6	15-9	6
12-217 - 12-228	0	15-10 - 15-27	0
12-229	3	15-28	11
12-230 - 12-231	2	15-29 - 15-34	0
12-232 - 12-254	0	15-35	7
12-255 - 12-257	2	15-36	2
12-258 - 12-285	0	15-36.1 - 15-36.8 Added	12
12-286	7	15-37	12
12-287 - 12-294	0	15-38	11
12-295 - 12-298	2	15-39	0
12-299	0	15-40	7
12-300	2	15-41 - 15-42	4
12-301 - 12-312	0	15-43 - 15-44	0
12-313	8	15-45	4
12-314 - 12-315	0	15-46	2
12-316 - 12-319	4	15-47	8
12-320	5	15-48 - 15-53	0
12-320.1 - 12-320.2 Added	4	15-54	8
12-321 Blank	4	15-55	4
12-322	4	15-56 - 15-62	0
12-323	0	15-63	11
12-324	2	15-64 - 15-79	0
12-325 - 12-326	0	15-80	6
12-327 - 12-328	2	15-81	0
12-329 - 12-334	0	15-82 Blank	0
12-334.1 Added	4	16-1	1
12-334.2 Blank	4	16-2 - 16-27	0
12-335 - 12-357	0	16-28	7
12-358 Blank	0	16-29 - 16-39	0
13-1	0	16-40	2
13-2	4	16-41 - 16-54	0
13-3 - 13-12	0	16-55	7
13-13	7	16-56	0
13-14 - 13-28	0	16-57 - 16-58	6
13-29 - 13-33	8	16-59 - 16-61	0
13-34	0	16-62	11
13-35	2	16-63 - 16-83	0
13-36	0	16-84 Blank	0
13-37 - 13-38	2	A-1 - A-2	1
13-39	0	Glossary-1	9
13-40	7	Glossary-2 - Glossary-22	0
13-41	2	Index-1	0
13-42 - 13-50	0	Index-2	6
13-51	4	Index-3 - Index-7	0
13-52 - 13-55	0	Index-8	6
13-56	4	Index-9	0

\*Zero in this column indicates an original page.

INSERT LATEST CHANGED PAGES: DESTROY SUPERSEDED PAGES.

**LIST OF EFFECTIVE PAGES**

Page No.	*Change No.	Page No.	*Change No.
Index-10 .....	9		
Index-11 - Index-12 .....	0		
Index-13 - Index-14 .....	9		
Index-15 - Index-16 .....	0		

\*Zero in this column indicates an original page.





HEADQUARTERS  
DEPARTMENT OF THE ARMY  
WASHINGTON, D. C., 30 April 1992

TECHNICAL MANUAL  
AVIATION UNIT AND INTERMEDIATE  
TROUBLESHOOTING MANUAL  
FOR  
ARMY MODEL  
AH-64A HELICOPTER  
NSN: (1520-01-106-9519) EIC: (RHA)

**REPORTING ERRORS AND RECOMMENDING IMPROVEMENTS**

You can help improve this manual. If you find any mistakes or if you know of a way to improve these procedures, please let us know. Mail your letter or DA Form 2028 (Recommended Changes to Publications and Blank Forms) located in the back of this manual, directly to: Commander, U.S. Army Aviation and Missile Command, ATTN: AMSAM-MMC-MA-NP, Redstone Arsenal, AL 35898-5000. A reply will be furnished to you. You may also provide DA Form 2028 information to AMCOM via e-mail, fax, or the World Wide Web. Our fax number is: DSN 788-6546 or Commercial 256-842-6546. Our e-mail address is: [2028@redstone.army.mil](mailto:2028@redstone.army.mil). Instructions for sending an electronic 2028 may be found at the back of this manual immediately preceding the hard copy 2028. For the World Wide Web use: <https://amcom2028.redstone.army.mil>.

**OZONE DEPLETING CHEMICAL INFORMATION:**

This document has been reviewed for the presence of Class I Ozone depleting chemicals. As of Change 8 dated 19 December 1997, all references to Class I Ozone depleting chemicals have been removed from this document by substitution with chemicals that do not cause atmospheric Ozone depletion.

**TABLE OF CONTENTS**

	<u>Title</u>	<u>Page No.</u>
	HOW TO USE THIS VOLUME .....	iii
CHAPTER 12	UTILITY SYSTEM	
	Section I Equipment Description and Data .....	12-3
	Section II Theory of Operation .....	12-29
	Section III Troubleshooting Procedures .....	12-51
CHAPTER 13		
	Section I Equipment Description and Data .....	13-2
	Section II Theory of Operation .....	13-11
	Section III Troubleshooting Procedures .....	13-16

\* **SUPERSEDURE NOTICE:** This manual supersedes TM 55-1520-238-T-8, dated 15 DECEMBER 1985, including all changes.

TABLE OF CONTENTS

	<u>Title</u>	<u>Page No.</u>
CHAPTER 14	HOISTS AND WINCHES (Not Applicable) .....	14-1
CHAPTER 15	AUXILIARY POWER UNIT	
Section I	Equipment Description and Data .....	15-2
Section II	Theory of Operation .....	15-12
Section III	Troubleshooting Procedures .....	15-14
CHAPTER 16	MISSION EQUIPMENT	
Section I	Equipment Description and Data .....	16-2
Section II	Theory of Operation .....	16-8
Section III	Troubleshooting Procedures .....	16-13
APPENDIX A	REFERENCES .....	A-1
GLOSSARY		
Section I	Abbreviations and Acronyms .....	Glossary-1
Section II	Common Names .....	Glossary-12
ALPHA INDEX .....		Index-1

**HOW TO USE THIS VOLUME**

**OVERVIEW**

If you can't find information, you can't do the job. Learn how to use the integrated troubleshooting manual series and this volume. Refer to TM 1-1520-238-T-2 for instructions on how to use the troubleshooting manual system and TM 1-1520-238-T-4 for instructions on how to use this volume.

**USING AH-64A HELICOPTER EFFECTIVITY CODES**

Helicopter effectivity codes designate differences between helicopters by helicopter serial numbers. These codes consist of 3 letters representing various helicopter serial number blocks. They are used throughout this volume as necessary to aid the helicopter troubleshooting effort.

The codes are used to designate serial number block differences as follows:

- When used within narrative text and fault isolation procedures (FIPs), effectivity codes appear within parentheses.  
For Example: Example: Narrative text and FIPs (AAA)
- When used inside wiring interconnect diagrams, effectivity codes appear within triangular borders and are placed on the line which represents that particular helicopter's configuration.

For Example: Example: Wiring interconnect diagram 

This volume uses these effectivity codes and corresponding helicopter serial numbers for reference.

To use the helicopter effectivity codes, note the helicopter serial number on the left-hand side of the fuselage directly below the CPG window. Use this serial number to determine which procedure or path in a wiring interconnect diagram or FIP to use.

The effectivity codes and helicopter serial number blocks applicable to this volume are as follows:

<b><u>Effectivity Code</u></b>	<b><u>Helicopter Serial No.</u></b>
AAA	82-23355 thru 82-23365
AAB	82-23355 thru 83-23798
AAC	82-23355 thru 83-23814
AAD	85-25424 and subsequent
AAE	82-23355 thru 84-24231
AAF	84-24216 and subsequent
AAG	82-23355 thru 84-24289
AAH	82-23355 thru 85-25398
AAJ	85-25351 and subsequent
AAK	82-23355 thru 85-25488
AAL	88-0215 and subsequent
AAM	85-25465 and subsequent
AAN	83-23787 thru 85-25415

---

**HOW TO USE THIS VOLUME (cont)**

---

**Effectivity Code****Helicopter Serial No.**

AAP	82-23355 thru 88-0214
AAQ	82-23355 thru 84-24311
AAR	82-23355 thru 84-24239
AAS	84-24240 and subsequent
AAT	82-23355 thru 83-23804
AAU	83-23787 and subsequent
AAV	83-23805 and subsequent
AAW	83-23799 and subsequent
AAX	83-23799 thru 84-24245
AAZ	83-23799 thru 85-25470 (Before MWO 1-1520-238-50-37)
ABA	83-23815 and subsequent
ABB	84-24200 and subsequent
ABC	84-24246 and subsequent
ABD	84-24290 and subsequent
ABE	82-23355 thru 85-25415
ABF	82-23355 thru 84-24295
ABG	84-24296 and subsequent
ABH	85-25399 and subsequent
ABJ	82-23355 thru 84-24245
ABK	85-25447 and subsequent
ABL	82-23355 thru 85-24446
ABM	82-23355 thru 89-0215
ABN	84-24290 thru 88-0199
ABP	89-0192 and subsequent
ABQ	85-25471 and subsequent
ABR	86-8940 and subsequent
ABS	82-23344 thru 84-24232
ABT	84-24233 and subsequent
ABU	82-23355 thru 83-23816
ABV	83-23817 thru 85-25415
ABW	84-24246 thru 85-25398
ABX	82-23355 thru 83-23795
ABY	83-23796 and subsequent
	With T700-GE 701 engines

---

**HOW TO USE THIS VOLUME (cont)**

---

<u>Effectivity Code</u>	<u>Helicopter Serial No.</u>
ABZ	With T700-GE 701C engines
ACA	82-23355 thru 88-0199
ACB	88-0200 and subsequent
ACC	82-23355 thru 83-23834
ACD	85-25416 and subsequent
ACE	82-23355 thru 86-9011
ACF	82-23355 thru 88-0284
ACG	89-0192 and subsequent
ACH	82-23355 thru 85-25423
ACJ	82-23355 thru 90-0290, 90-0292 thru 90-0301 (Before MWO 1-1520-238-50-07)
ACK	82-23355 thru 90-0290, 90-0292 thru 90-0301 (After MWO 1-1520-238-50-07) 90-0291, 90-0302 and subsequent
ACL	82-23355 thru 83-23814
ACM	83-23815 and subsequent
ACN	85-25471 thru 90-0448 (Before MWO 1-1520-238-50-37)
ACP	85-25471 thru 90-0448 (After MWO 1-1520-238-50-37) 90-0449 and subsequent
ACQ	82-23355 thru 90-0448 (Before MWO 1-1520-238-50-36)
ACR	82-23355 thru 90-0448 (After MWO 1-1520-238-50-36) 90-0449 and subsequent
ACS	82-23355 thru 90-0437
ACT	90-0438 and subsequent
ACU	82-23355 thru 90-0436
ACV	89-0192 thru 90-0434 with T700-GE-701C engines (Before MWO 1-1520-238-50-38)
ACW	89-0192 thru 90-0434 with T700-GE-701C engines (After MWO 1-1520-238-50-38) 90-0435 and subsequent with T700-GE-701C engines
ACY	82-23355 thru 92-0485 (Before MWO 9-1230-476-50-01)
ACZ	82-23355 thru 92-0485 (After MWO 9-1230-476-50-01) 86-08940 and subsequent
ADC	Before MWO 1-1520-238-50-49

**HOW TO USE THIS VOLUME (cont)**

**Effectivity Code**

**Helicopter Serial No.**

ADD	After MWO 1-1520-238-50-49
ADJ	82-233355 thru 82-23361
ADK	82-233361 and subsequent

**USING THE ELECTRICAL COMPONENT LOCATION AND CONFIGURATION (ECLC) INDEX**

The ECLC index will help you find electrical components and their connectors on the helicopter during troubleshooting. The ECLC is located at the beginning of the troubleshooting procedures of each chapter (when applicable). This index is a list of connectors and applicable component or wiring harnesses which are illustrated by component location. Component locations are shown from the helicopter's forward sections to its aft sections by horizontal and vertical grid numbers. Connectors are listed numerically in the **FROM COLUMN Connector Ref Des** column of the index. Every connector is referenced to a grid area within the illustrations.

**EXAMPLE OF ECLC INDEX**

<b>FROM COLUMN</b>		<b>TO COLUMN</b>		<b>Grid Area</b>	<b>Access</b>
<b>Connector Ref Des</b>	<b>Component/Harness</b>	<b>Connector Ref Des</b>	<b>Component/Harness</b>		
P910	W102	J910	W211	48B	R295 DOOR
P916	W118	J916	W119	1D	CPG STATION
P941	W268	J1	L44	44D	B200

Use the index to find connectors on the aircraft by first locating the connector reference designator number in the **FROM COLUMN Connector Ref Des** column of the index. Then, cross-reference the **FROM COLUMN Connector Ref Des** column with the following:

- **FROM COLUMN Component/Harness** column to locate the component or wire harness number.
- **TO COLUMN Connector Ref Des** column to locate the mating connector number.
- **TO COLUMN Component/Harness** column to locate the mating component or wire harness number.
- **Grid Area** column to find the grid zone (within the illustration) depicting the location of the connector on the aircraft.
- **Access** column to find where access to the connector can be obtained (TM 1-1520-238-23).

---

**HOW TO USE THIS VOLUME (cont)**

---

For example, to locate connector P910 on the aircraft find connector P910 in the **FROM COLUMN Connector Ref Des** column, and then refer to the **FROM COLUMN Component/Harness** column. This column shows that P910 is part of wire harness W102. The **TO COLUMN Connector/Ref Des** column shows that P910 connects to J910 on wire harness W211. The **Grid Area** column indicates that P910 is depicted at illustration grid zone 48B, and that **Access** to the connector is obtained through the R295 DOOR.





# CHAPTER 12

## UTILITY SYSTEMS

### CHAPTER INDEX

<u>Para Title</u>	<u>Para No.</u>
<b>SECTION I. EQUIPMENT DESCRIPTION AND DATA</b>	
Equipment Characteristics, Capabilities, and Features .....	12-1
Location and Description of Major Components .....	12-2
Equipment Data .....	12-3
Equipment Configuration .....	12-4
Safety, Care and Handling of Equipment .....	12-5
Controls and Indicators .....	12-6
<b>SECTION II. THEORY OF OPERATION</b>	
System Description .....	12-7
Multiplex Read Codes .....	12-8
<b>SECTION III. TROUBLESHOOTING PROCEDURES</b>	
Electrical Component Location and Configuration (ECLC) Index .....	12-9
Canopy Defog and Anti-Ice - Power Up .....	12-10
Canopy Defog and Anti-Ice - Power Down .....	12-11
Canopy Defog and Anti-Ice - Maintenance Operational Check .....	12-12
Canopy Defog and Anti-Ice - Wiring Interconnect Diagram .....	12-13
Engine Anti-Ice - Maintenance Operational Check .....	12-25
Engine Anti-Ice - Wiring Interconnect Diagram .....	12-26
Pitot Anti-Ice - Power Up .....	12-54
Pitot Anti-Ice - Power Down .....	12-55
Pitot Anti-Ice - Maintenance Operational Check .....	12-56
Pitot Anti-Ice - Wiring Interconnect Diagram .....	12-57
Rotor Blades De-Ice - Maintenance Operational Check .....	12-62
Rotor Blades De-Ice - Wiring Interconnect Diagram .....	12-63
Windshield Wipers - Power Up .....	12-85
Windshield Wipers - Power Down .....	12-86
Windshield Wipers - Maintenance Operational Check .....	12-87
Windshield Wipers - Wiring Interconnect Diagram .....	12-88
Engine 1 Fire Detection - Power Up .....	12-97
Engine 1 Fire Detection - Power Down .....	12-98

CHAPTER INDEX (cont)

<u>Para Title</u>	<u>Para No.</u>
Engine 1 Fire Detection - Maintenance Operational Check .....	12-99
Engine 1 Fire Detection - Wiring Interconnect Diagram .....	12-100
Engine 2 Fire Detection - Power Up .....	12-1 10
Engine 2 Fire Detection - Power Down .....	12-1 11
Engine 2 Fire Detection - Maintenance Operational Check .....	12-1 12
Engine 2 Fire Detection - Wiring Interconnect Diagram .....	12-1 13
APU Fire Detection - Power Up .....	12-121
APU Fire Detection - Power Down .....	12-122
APU Fire Detection - Maintenance Operational Check .....	12-123
APU Fire Detection - Wiring Interconnect Diagram .....	12-124
Fire Extinguishers - Power Up .....	12-131
Fire Extinguishers - Power Down .....	12-132
Fire Extinguishers - Maintenance Operational Check .....	12-133
Fire Extinguishers - Wiring Interconnect Diagram .....	12-134

## SECTION I. EQUIPMENT DESCRIPTION AND DATA

---

### 12-1. EQUIPMENT CHARACTERISTICS, CAPABILITIES, AND FEATURES

---

12-1

#### a. Characteristics.

(1) **Canopy Defog and Anti-Ice System.** The canopy defog system removes fog by blowing hot air on the pilot and copilot/gunner (CPG) windshields. The anti-ice system prevents ice using electrical heating elements in the aircraft windshields, target acquisition designation sight (TADS) windows and pilot night vision sensor (PNVS) window.

(2) **Engine Anti-Ice System.** The engine anti-ice system uses electrical heating elements and compressor bleed air to prevent engine ice.

(3) **Pitot Anti-Ice System.** The pitot anti-ice system uses electrical heating elements to prevent ice accumulation.

(4) **Rotor Blades De-Ice System.** The rotor blades de-ice system provides controlled ice removal from the main and tail rotor blades using electrically heated blankets that are bonded to the blades.

(5) **Windshield Wipers.** The windshield wipers remove moisture from the pilot and CPG windshields using wiper blades.

(6) **Engine 1 Fire Detection System.** The engine 1 fire detection system uses optical sensing devices to detect fire.

(7) **Engine 2 Fire Detection System.** The engine 2 fire detection system uses optical sensing devices to detect fire.

(8) **Auxiliary Power Unit (APU) Fire Detection System.** The APU fire detection system uses optical sensing devices to detect fire.

(9) **Fire Extinguishers System.** The fire extinguishers system uses a pressurized chemical fire extinguishing agent to extinguish fires in the engine and APU compartments.

#### b. Capabilities and Features.

(1) **Canopy Defog and Anti-Ice System.** The canopy defog system allows the pilot to control the flow of hot air on the windshields to remove fog. The anti-ice system allows the pilot to control heating elements in the windshields and TADS/PNVS windows to prevent or remove ice.

(2) **Engine Anti-Ice System.** The engine anti-ice system prevents engine ice by directing compressor bleed air onto engine components and electrically heating the nose gearbox (NGB). Compressor bleed air flow is directed to the engine components by control valves and air temperature sensing switches. The NGB and upper aft fairing heaters maintain the NGB and upper aft fairing temperature between 225°F (107°C) and 235°F (113°C) through control units.

(3) **Pitot Anti-Ice System.** The Pitot anti-ice system uses heating elements, mounted in the left and right Pitot tubes, to prevent ice accumulation when energized. The pilot controls the operation of the heating elements.

(4) **Rotor Blades De-Ice System.** The rotor blades de-ice system provides ice removal in trace to moderate icing conditions. The main and tail rotor blades can be de-iced automatically or manually.

12-1. EQUIPMENT CHARACTERISTICS, CAPABILITIES, AND FEATURES (cont)

12-1

(5) **Windshield Wipers.** The windshield wipers can be operated at low and high speeds and provide windshield clearing in heavy rain conditions of up to 1.6 inches per hour at airspeeds of up to 204 knots.

(6) **Engine 1 Fire Detection System.** The engine 1 fire detection system senses fire and lights engine 1 fire pull handle on pilot L/H instrument panel and the CPG L/H glareshield fire extinguisher panel.

(7) **Engine 2 Fire Detection System.** The engine 2 fire detection system senses fire and lights engine 2 fire pull handle on pilot L/H instrument panel and the CPG L/H glareshield fire extinguisher panel.

(8) **APU Fire Detection System.** The APU fire detection system senses fire and lights the APU fire pull handle on the APU panel on the pilots R/H aft console and the APU fire indicator on the pilot and CPG master caution/warning panels.

(9) **Fire Extinguishers System.** The fire extinguishers system allows the pilot and CPG to discharge stored fire extinguishing agent to extinguish fires in the engine and APU compartments.

12-2. LOCATION AND DESCRIPTION OF MAJOR COMPONENTS

12-2

a. **Canopy Defog and Anti-Ice System.** The canopy defog and anti-ice system consists of the defog shutoff valve, canopy heating elements, canopy temperature sensor, canopy temperature control, TADS heating elements and PNVs heating element.

(1) **Defog Shutoff Valve.** The defog shutoff valve (fig. 12-1), located in the aft equipment bay on the left engine louver housing, is a normally closed, 28 VDC electrically actuated air operated poppet valve. The defog shutoff valve provides on/off control of hot air to the windshields.

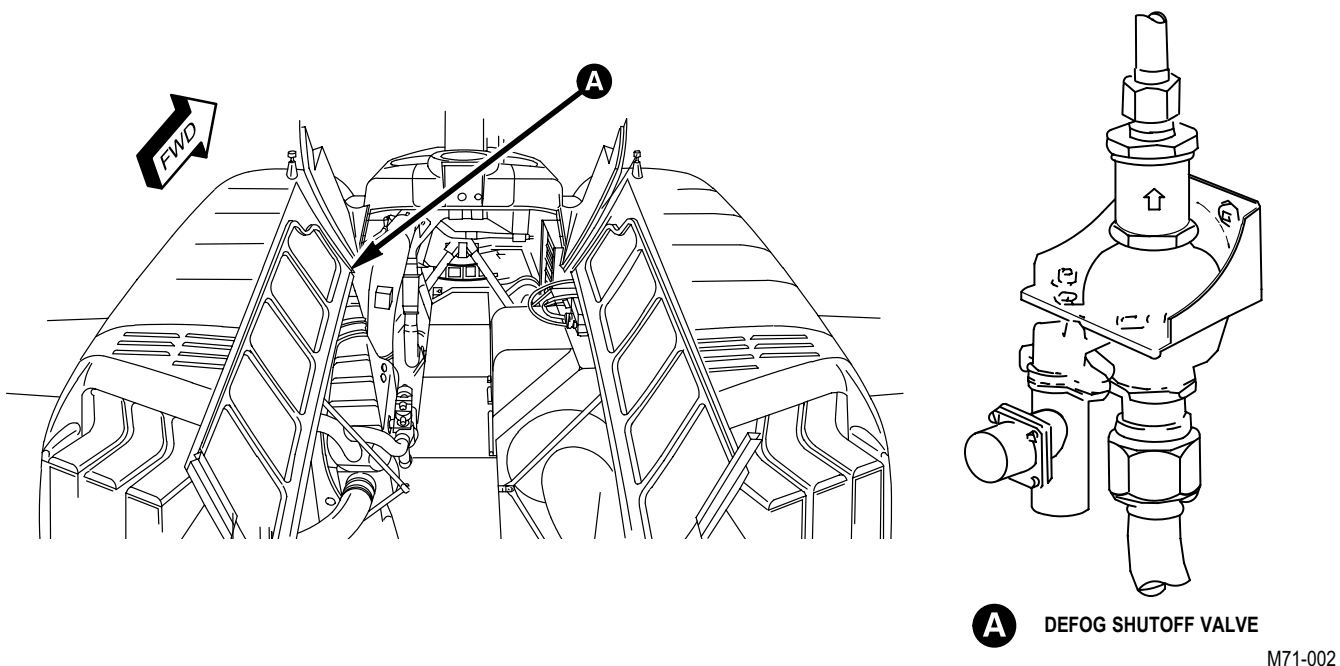

Figure 12-1. Defog Shutoff Valve Location

(2) **Canopy Heating Elements.** Canopy heating elements (fig. 12-2), bonded between the inner and outer plies of the pilot and CPG windshields, are joined together in a 3-phase, 115/200 VAC delta connection.

12-2. LOCATION AND DESCRIPTION OF MAJOR COMPONENTS (cont)

12-2

(3) **Canopy Temperature Sensor.** The canopy temperature sensor, bonded between the inner and outer plies of the pilot windshield, is a sensing element with a positive temperature coefficient that monitors canopy temperature.

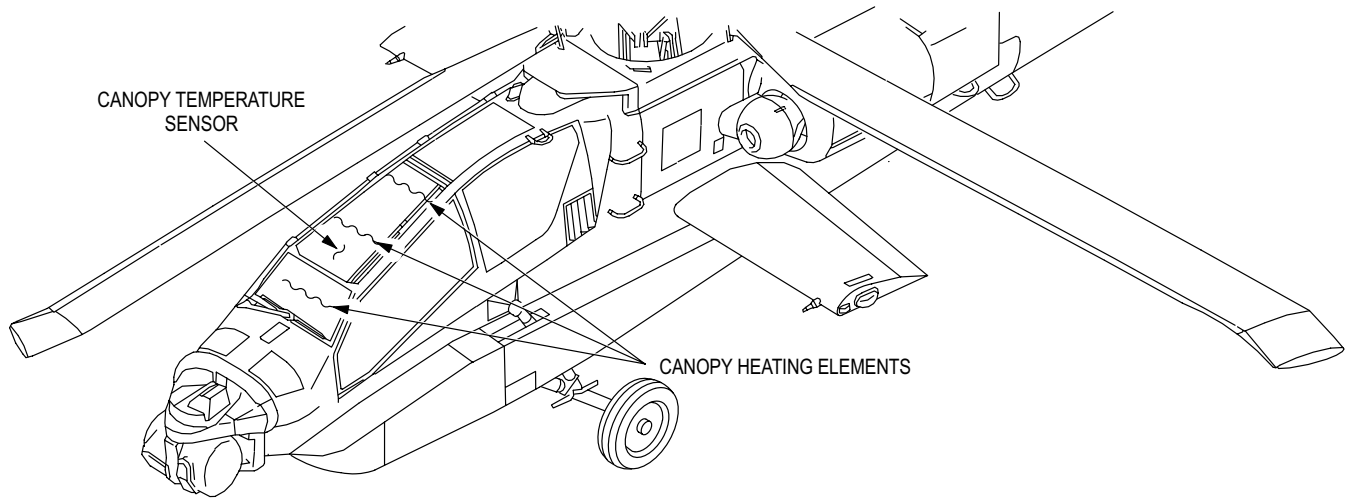

M71-001

**Figure 12-2. Canopy Heating Elements and Canopy Temperature Sensor Location**

(4) **Canopy Temperature Control.** The canopy temperature control (fig. 12-3), located in the CPG left console under the recorder control panel, is a solid state unit using 28 VDC control power and 3-phase 115/200 VAC heating element power. The canopy anti-ice temperature control unit monitors and controls canopy temperature.

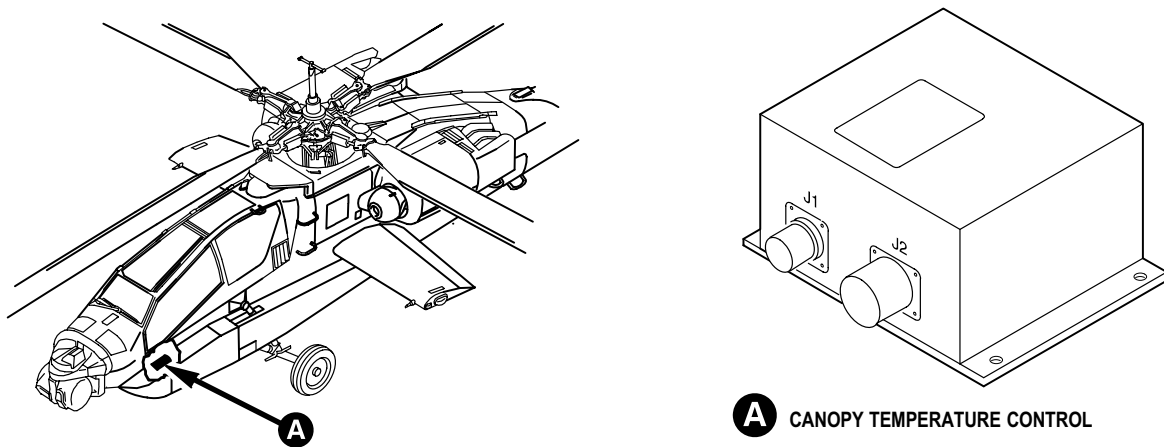

M71-004A

**Figure 12-3. Canopy Temperature Control Location**

(5) **TADS Heating Elements.** TADS heating elements (fig. 12-4), bonded between the inner and outer plies of the TADS windows, use 3-phase 115/200 VAC power.

(6) **PNVS Heating Element.** The PNVS heating element, bonded between the inner and outer plies of the PNVS window, uses single phase 115 VAC power.

## 12-2. LOCATION AND DESCRIPTION OF MAJOR COMPONENTS (cont)

12-2

b. **Engine Anti-Ice System.** The engine anti-ice system consists of the engine anti-ice bleed/start valve, thermal switch, engine inlet anti-ice valve, NGB heater, upper aft fairing heater, control unit and bleed air relay.

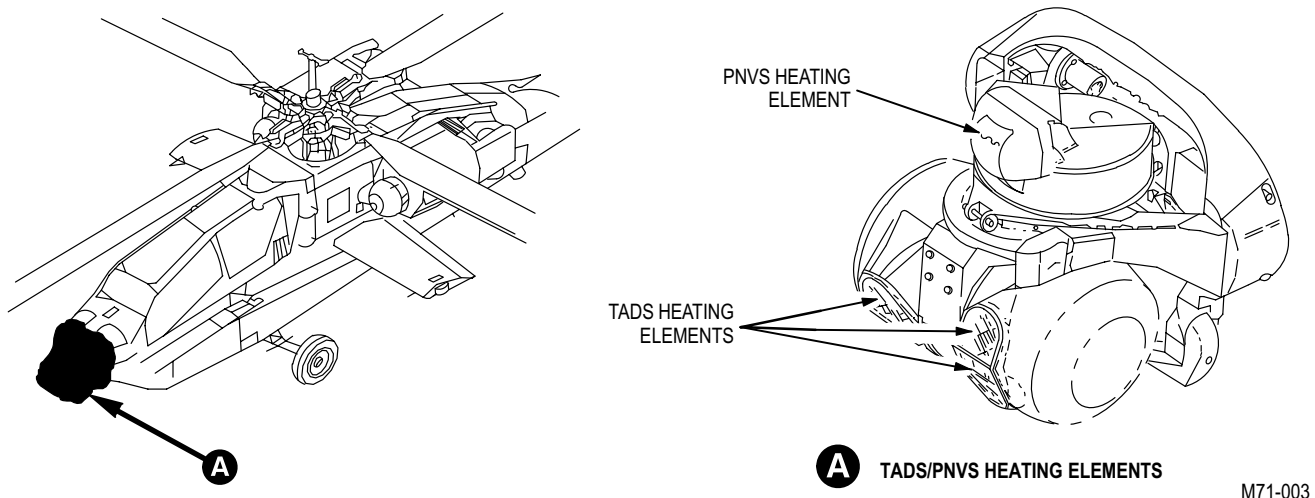

Figure 12-4. TADS/PNVS Heating Elements Location

(1) **Engine Anti-Ice Bleed/Start Valve.** The engine anti-ice bleed/start valve (fig. 12-5), located on the lower left side of the compressor stator of each engine, is a spring loaded open valve that controls anti-icing airflow to the engine and bleeds air from the compressor during start and low engine speeds. The engine anti-ice bleed/start valve is controlled mechanically by a variable geometry actuator and electrically by a solenoid valve.

(2) **Thermal Switch.** The thermal switch (fig. 12-6), mounted in the bleed air tube between the engine inlet anti-ice valve and engine inlet fairing of each engine, energizes the bleed air relay. It is a normally open switch that will respond to a temperature change in 40 seconds or less.

(3) **Engine Inlet Anti-Ice Valve.** The engine inlet anti-ice valve, located on the outboard side of the main cold frame section of each engine, controls anti-icing airflow to the engine inlet fairings. The engine inlet anti-ice valve is an electrically controlled, spring loaded open pneumatic valve.

(4) **NGB Heater.** The NGB heater (fig. 12-7) is an integral part of the forward and aft NGB fairings. The heater elements require 3-phase 115/200 VAC power.

(5) **Upper Aft Fairing Heater.** The upper aft fairing heater, an integral part of the upper aft fairing, require 3-phase 115/200 VAC power.

(6) **Control Unit.** The control unit, an integral part of the forward NGB fairing, consists of a control sensor and a safety sensor which controls the operation of the NGB and upper aft fairing heaters.

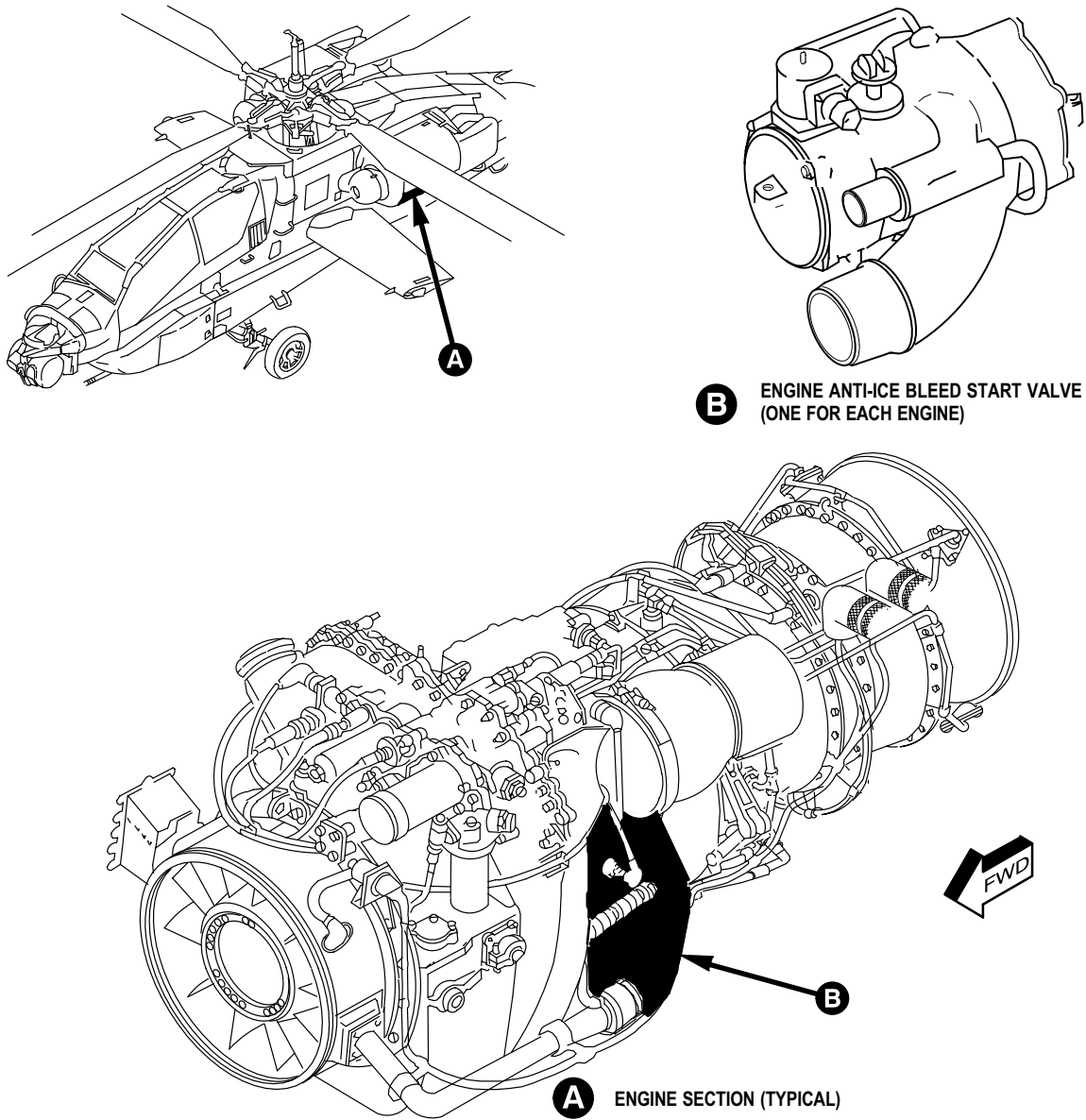

M71-025

Figure 12-5. Engine Anti-Ice Bleed/Start Valve Location

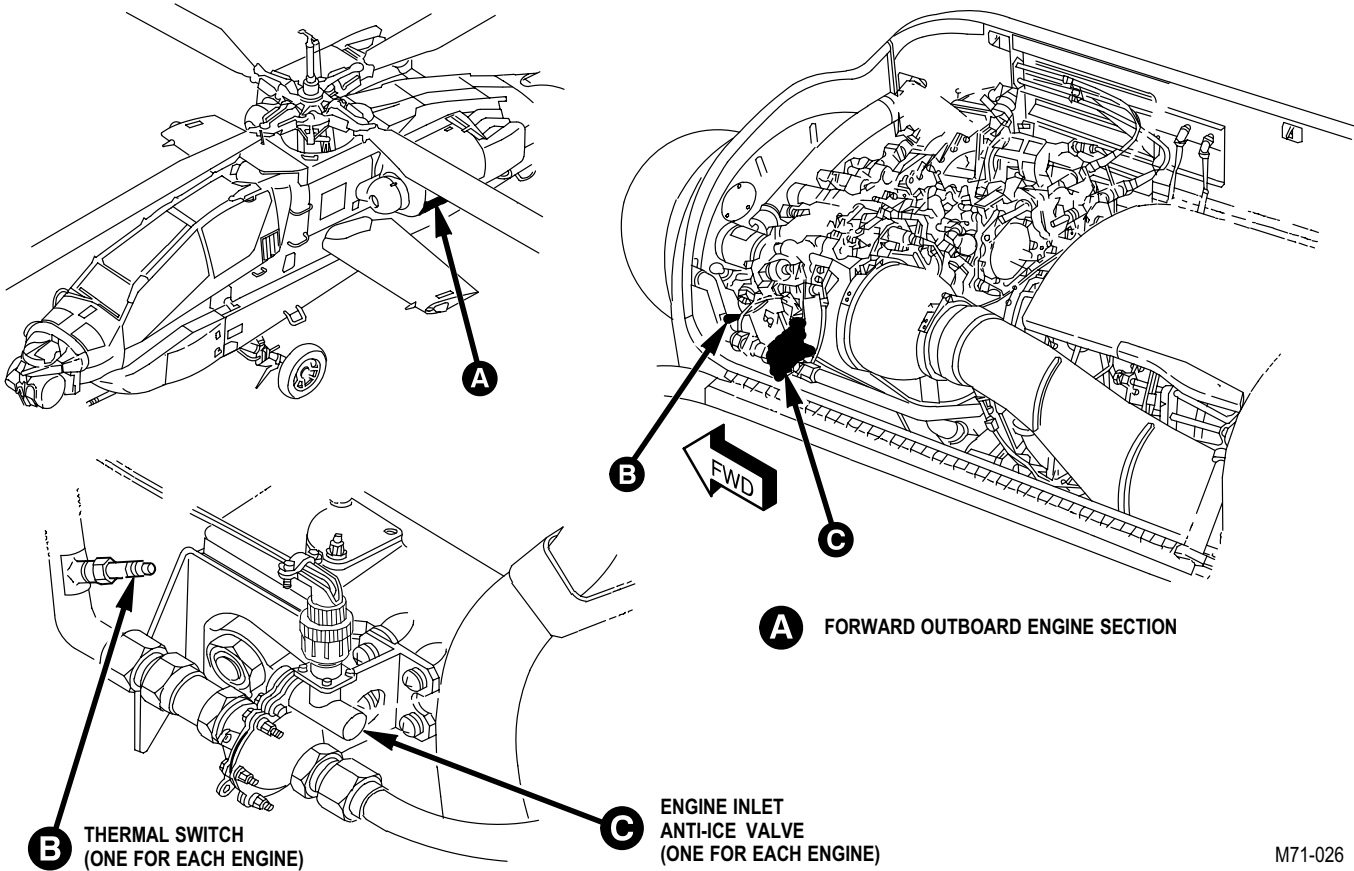

M71-026

Figure 12-6. Thermal Switch and Engine Inlet Anti-Ice Valve Location

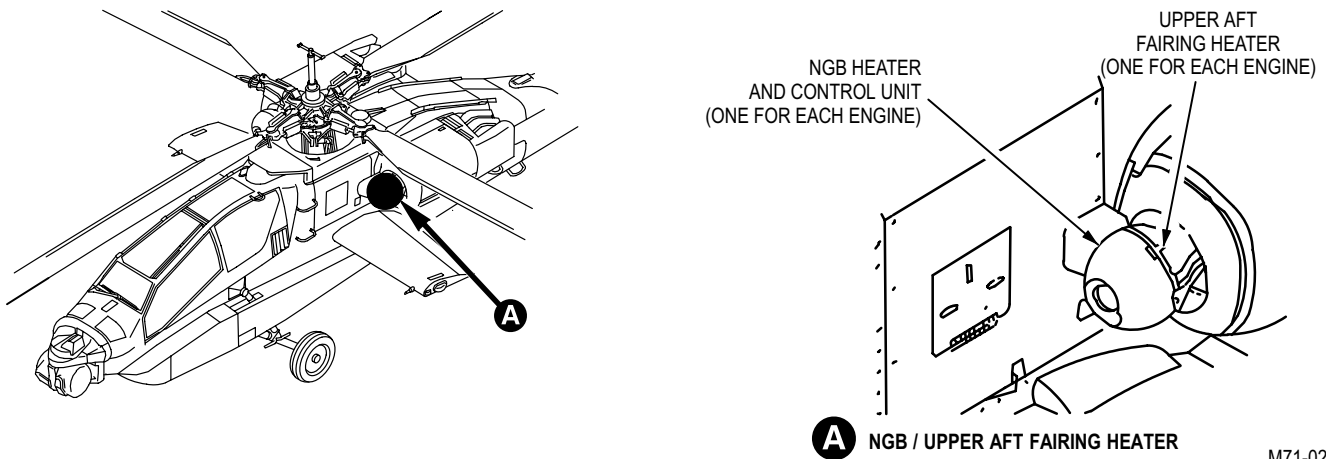

M71-024

Figure 12-7. NGB Heater, Upper Aft Fairing Heater And Control Unit Location

(7) **Bleed Air Relay.** The engine 1 bleed air relay (K1-1) and engine 2 bleed air relay (K1-2) (fig. 12-8), located on left side aft catwalk, energize the applicable **ENG ANTI ICE** indicator on the pilot and CPG caution/warning panels.



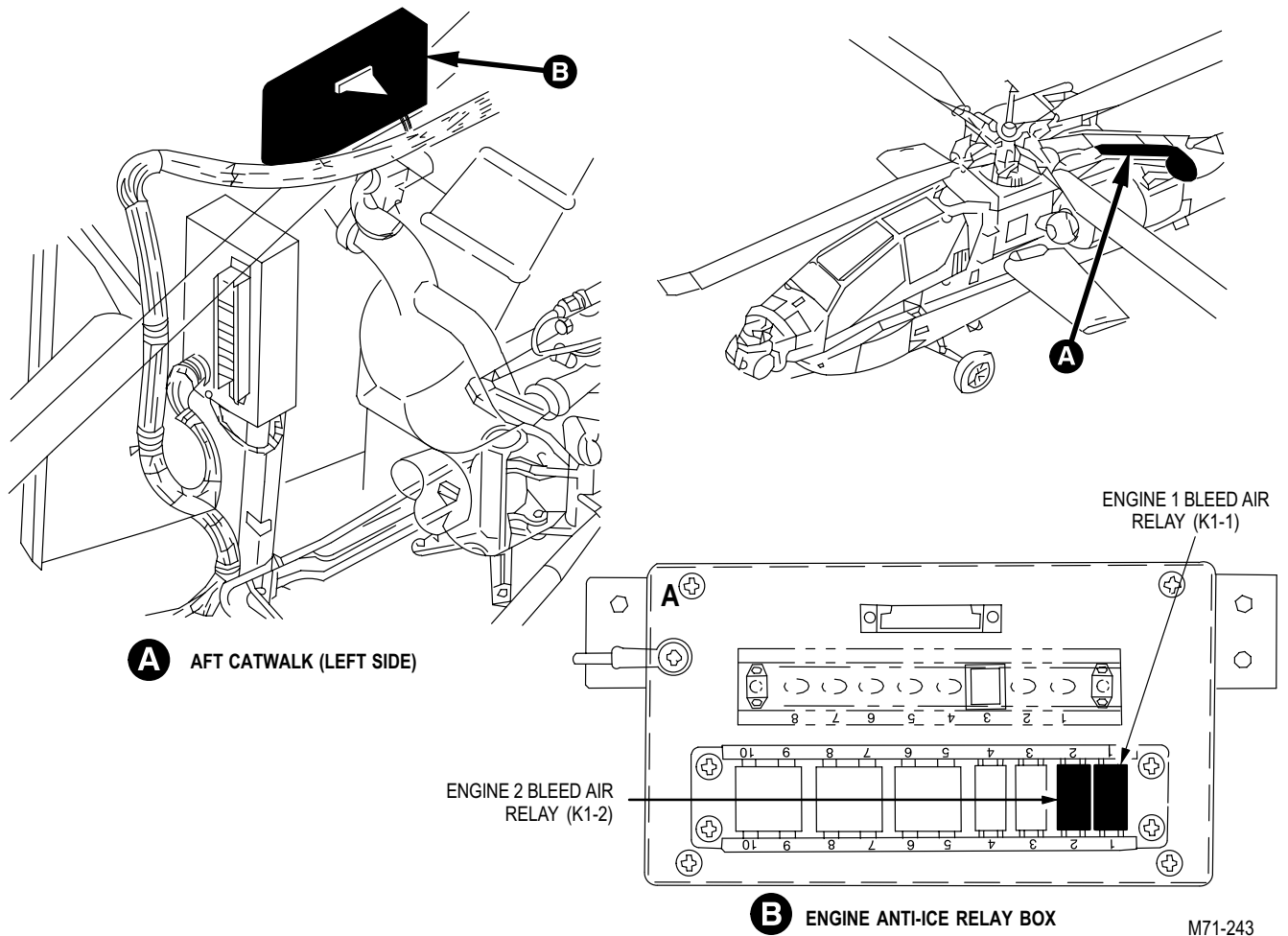

Figure 12-8. Bleed Air Relay Location

c. **Pitot Anti-Ice System.** The Pitot anti-ice system consists of electrical heating elements mounted in the Pitot tubes. Pitot tube heaters (fig. 12-9) are 28 VDC resistive heating elements located in the Pitot tubes on the left and right wings.

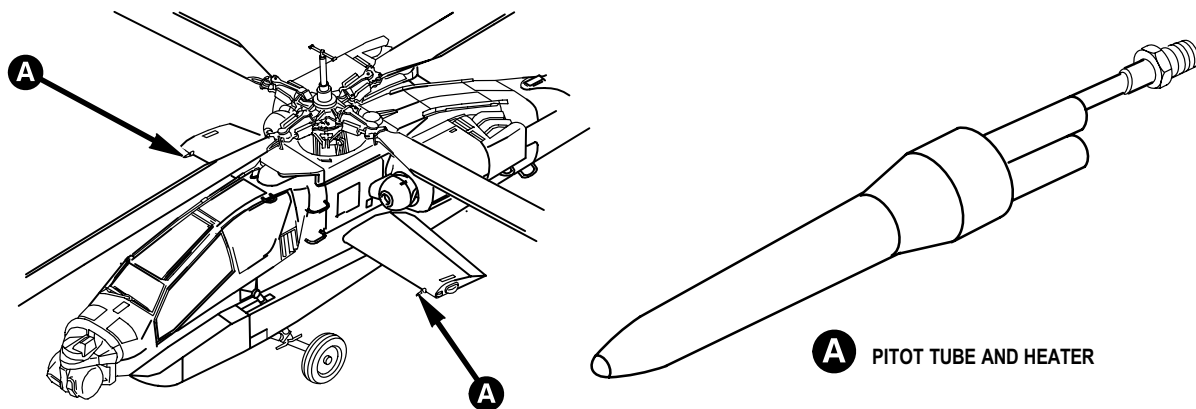

Figure 12-9. Pitot Tube Heater Location

---

**12-2. LOCATION AND DESCRIPTION OF MAJOR COMPONENTS (cont)**

---

12-2

d. **Rotor Blade De-Ice System.** The rotor blade de-ice system consists of the ice detector relay (K5-10), blade de-ice relay (K1-6), blade de-ice remote control circuit breaker (RCCB) (K-3), rotor blade de-ice controller, outside air temperature (OAT) sensor, ice detector sensor, ice detector signal processor, ice detector warm air supply valve, main rotor blade de-ice blankets, tail rotor blade de-ice blankets, main rotor slip ring assembly, main rotor distributor assembly and tail rotor slip ring assembly.

(1) **Ice Detector Relay.** The ice detector relay (K5-10) (fig. 12-10), located in the electrical power distribution box, connects 28 VDC and 115 VAC to rotor blade de-ice components.

(2) **Blade De-Ice Relay.** The blade de-ice relay (K1-6), located in the electrical power distribution box, provides a ground to energize the blade de-ice RCCB (K3).

(3) **Blade De-Ice RCCB.** The blade de-ice RCCB, located in the electrical power distribution box, provides power and control connections to the rotor blade de-ice controller.

(4) **Rotor Blade De-Ice Controller.** The rotor blade de-ice controller (fig. 12-11), located in the forward right side of the main transmission bay, determines main and tail rotor heater operating times and rectifies 115/200 VAC input to  $\pm 134$  VDC heater voltage.

(5) **OAT Sensor.** The OAT sensor, located between the right wing and engine 2 nacelle, is a resistive temperature sensor that provides OAT information to the rotor blade de-ice controller.

(6) **Ice Detector Sensor.** The ice detector sensor, located on the upper right side of the fuselage forward of the rotor head, is a vibrating probe enclosed in a housing that provides a signal to the ice detector signal processor.

(7) **Ice Detector Signal Processor.** The ice detector signal processor (fig. 12-12), located on the top center firewall of the engine 1 nacelle, contains a solid state inverter which inverts 28 VDC to  $5 \pm 1$  VAC for the ice detector sensor vibrating probe.

(8) **Ice Detector Warm Air Supply Valve.** The ice detector warm air supply valve, located on the upper fairing in the left side of the aft equipment bay inboard of engine 1, is solenoid operated open and spring loaded closed. The ice detector warm air supply valve, part of the pressurized air system (PAS), controls PAS airflow to the ice detector sensor housing.

(9) **Main Rotor Blade De-Ice Blankets.** The main rotor blade de-ice blankets (fig. 12-13) are thermally conductive composite blankets that contain etched foil heating elements. The blankets are internally bonded to the top and bottom of the main rotor blades.

(10) **Tail Rotor Blade De-Ice Blankets.** The tail rotor blade de-ice blankets are thermally conductive composite blankets that contain etched foil heating elements. The blankets are internally bonded to the top and bottom of the tail rotor blades.

12-2. LOCATION AND DESCRIPTION OF MAJOR COMPONENTS (cont)

12-2

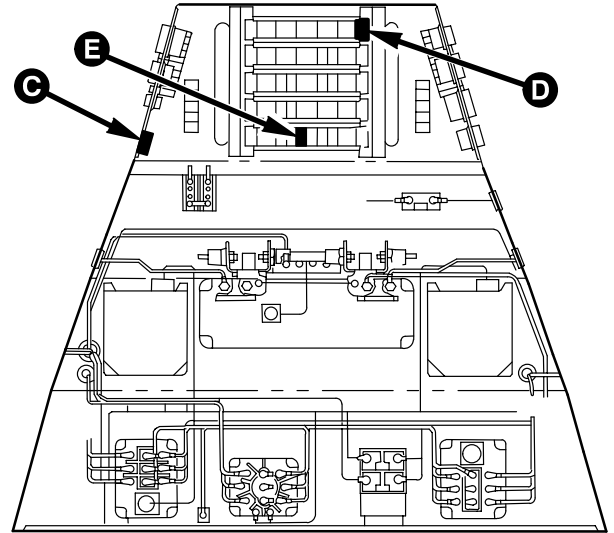
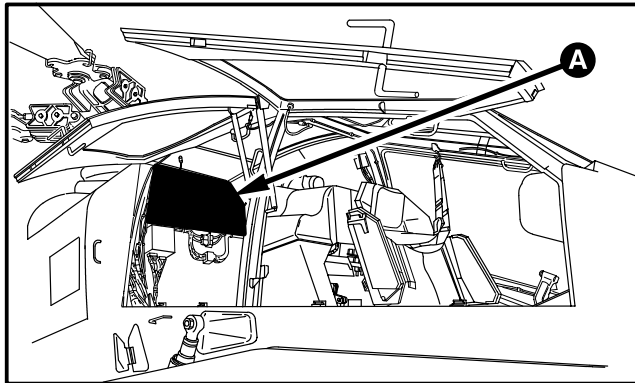

**B** ELECTRICAL POWER DISTRIBUTION BOX (RIGHT SIDE)

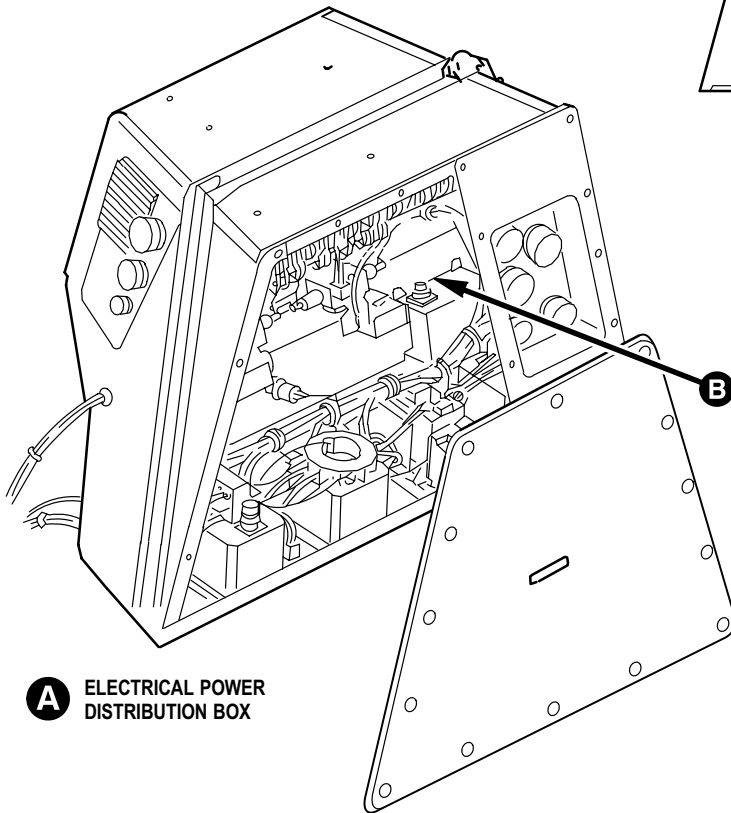

**A** ELECTRICAL POWER DISTRIBUTION BOX

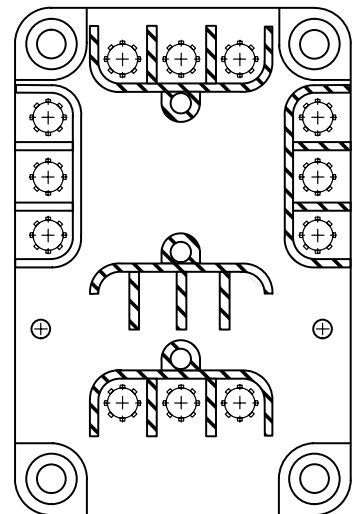

**C** BLADE DE-ICE RCCB (K-3)

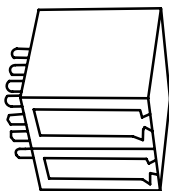

**E** BLADE DE-ICE RELAY (K1-6)

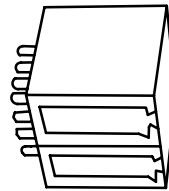

**D** ICE DETECTOR RELAY (K5-10)

M71-045

Figure 12-10. RCCB And Relay Location

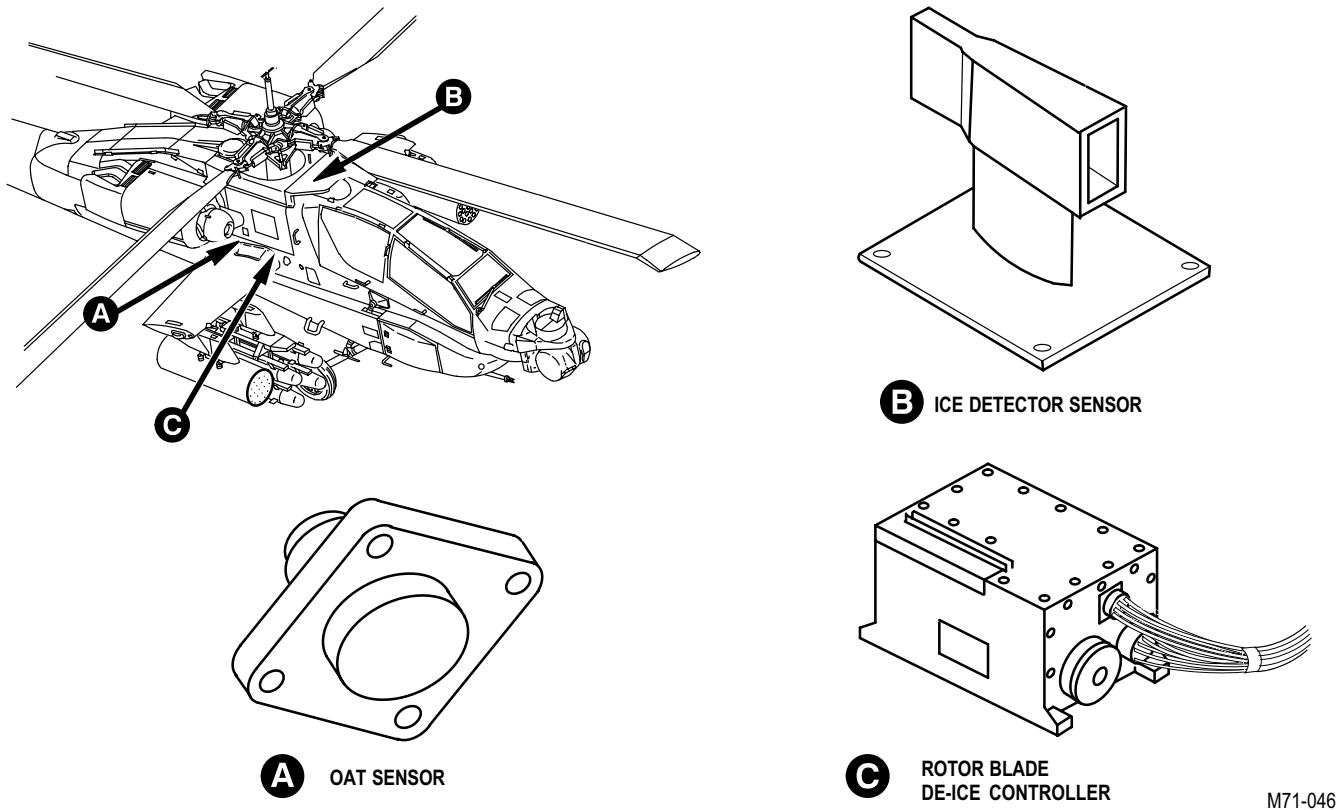

Figure 12-11. Rotor Blades De-Ice Major Component Location

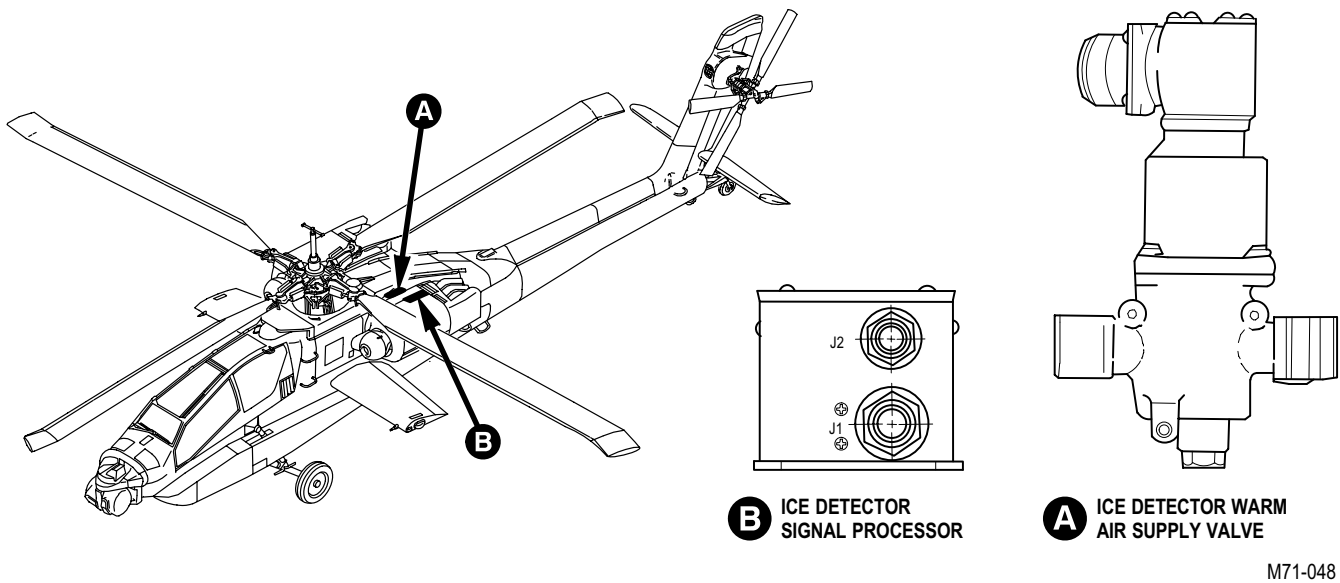
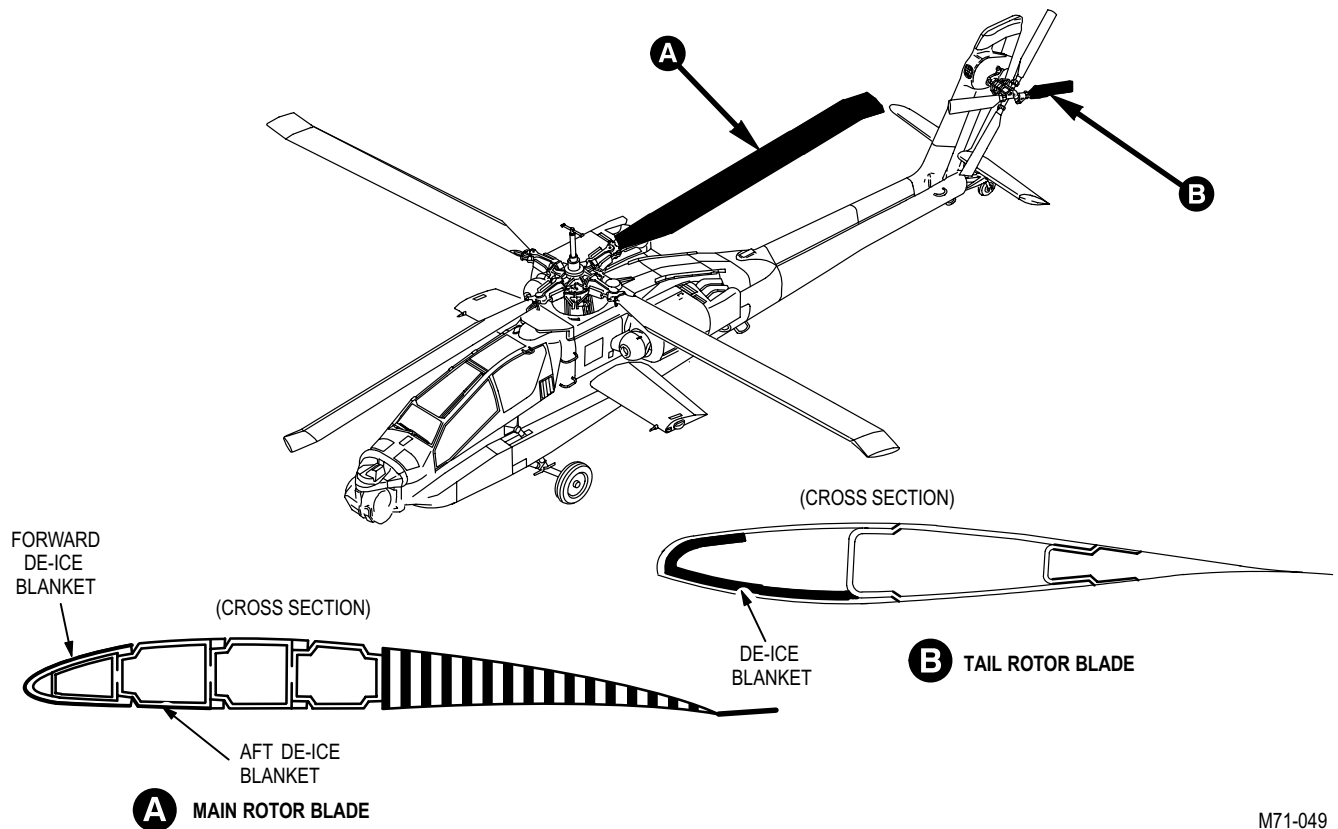

Figure 12-12. Ice Detector Signal Processor And Ice Detector Warm Air Supply Valve Location



M71-049

**Figure 12-13. Rotor Blade De-Ice Blankets Location**

(11) **Main Rotor Slip Ring Assembly.** The main rotor slip ring assembly (fig. 12-14), located on the main rotor, consists of a stationary ring and two rotating slip rings and carbon brushes. The main rotor slip ring assembly connects +134 VDC to -134 VDC from the rotor blade de-ice controller to the main rotor distributor assembly.

(12) **Main Rotor Distributor Assembly.** The main rotor distributor assembly, part of the main rotor slip ring assembly, is a cylindrical, environmentally sealed housing containing a stepper switch. The main rotor distributor assembly supplies +134 VDC to -134 VDC to the main rotor blades de-ice blankets.

(13) **Tail Rotor Slip Ring Assembly.** The tail rotor slip ring assembly, located on the tail rotor, consists of a stationary housing assembly and two rotating slip rings and carbon brushes. The tail rotor slip ring assembly connects +134 VDC to -134 VDC from the rotor blade de-ice controller to the tail rotor blades de-ice blankets.

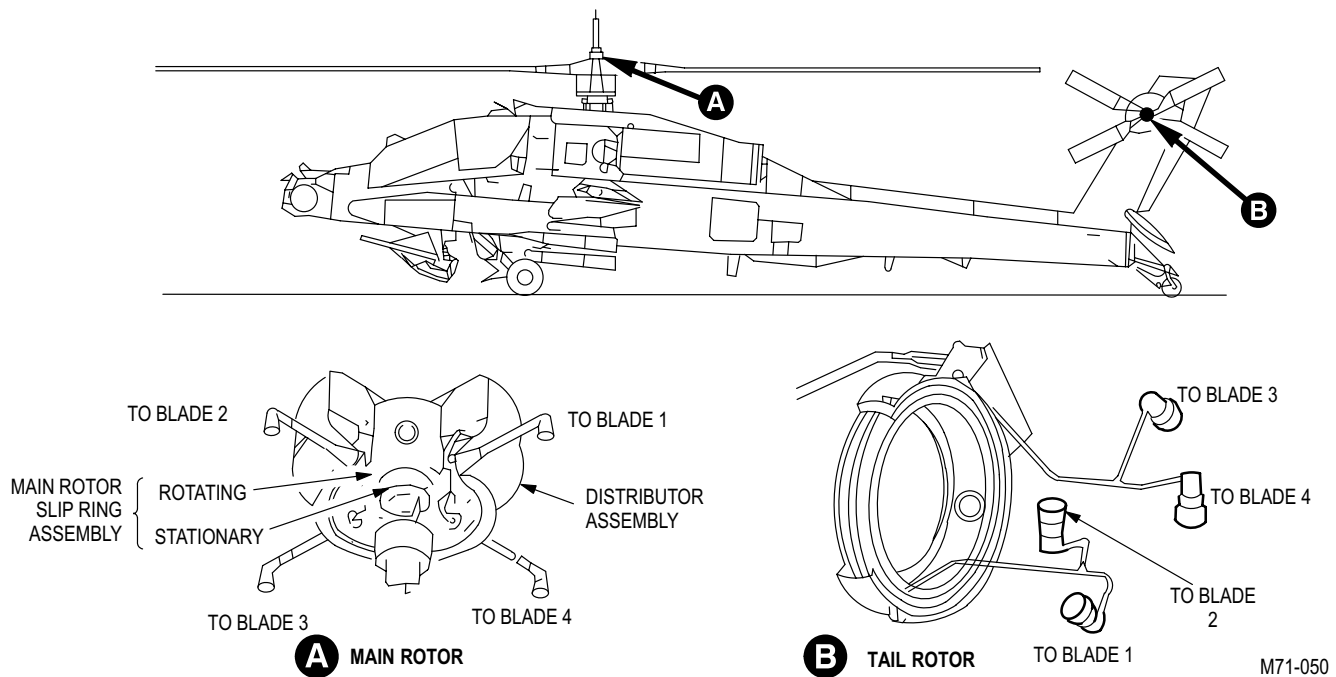

**Figure 12-14. Slip Ring Assemblies and Main Rotor Distributor Assembly Location**

e. **Windshield Wipers.** The windshield wipers (fig. 12-15) consists of the pilot and CPG windshield wiper assemblies, pilot and CPG wiper motors, pilot and CPG converters and pilot and CPG flexdrives.

(1) **Windshield Wiper Assemblies.** The windshield wiper assemblies, located on the pilot and CPG windshields, consist of a wiper arm, link and wiper blade.

(2) **Wiper Motors.** The wiper motors, located in the left and right nose equipment bays, are unidirectional, noise filtered continuous duty motors which drive the windshield wiper assemblies.

(3) **Flexdrives.** The flexdrives, connected between the pilot and CPG wiper motors and converters, are flexible driveshafts which transmit the rotary output of each motor to the converters.

(4) **Converters.** The converters, located at the base of the pilot and CPG windshield wiper assemblies, convert rotary motion to oscillating motion.

f. **Engine 1 Fire Detection System.** The engine 1 fire detection system (fig. 12-16) consists of flame detectors and a flame detector amplifier.

(1) **Flame Detector.** The flame detector, located in the lower forward outboard section and upper aft inboard section of the engine 1 compartment, is an optical sensing device that uses photocells to produce an electrical signal when flame is detected.

(2) **Flame Detector Amplifier.** The flame detector amplifier, located on the inboard side of the engine 1 firewall in the aft equipment bay, controls circuitry for the fire warning indicators.

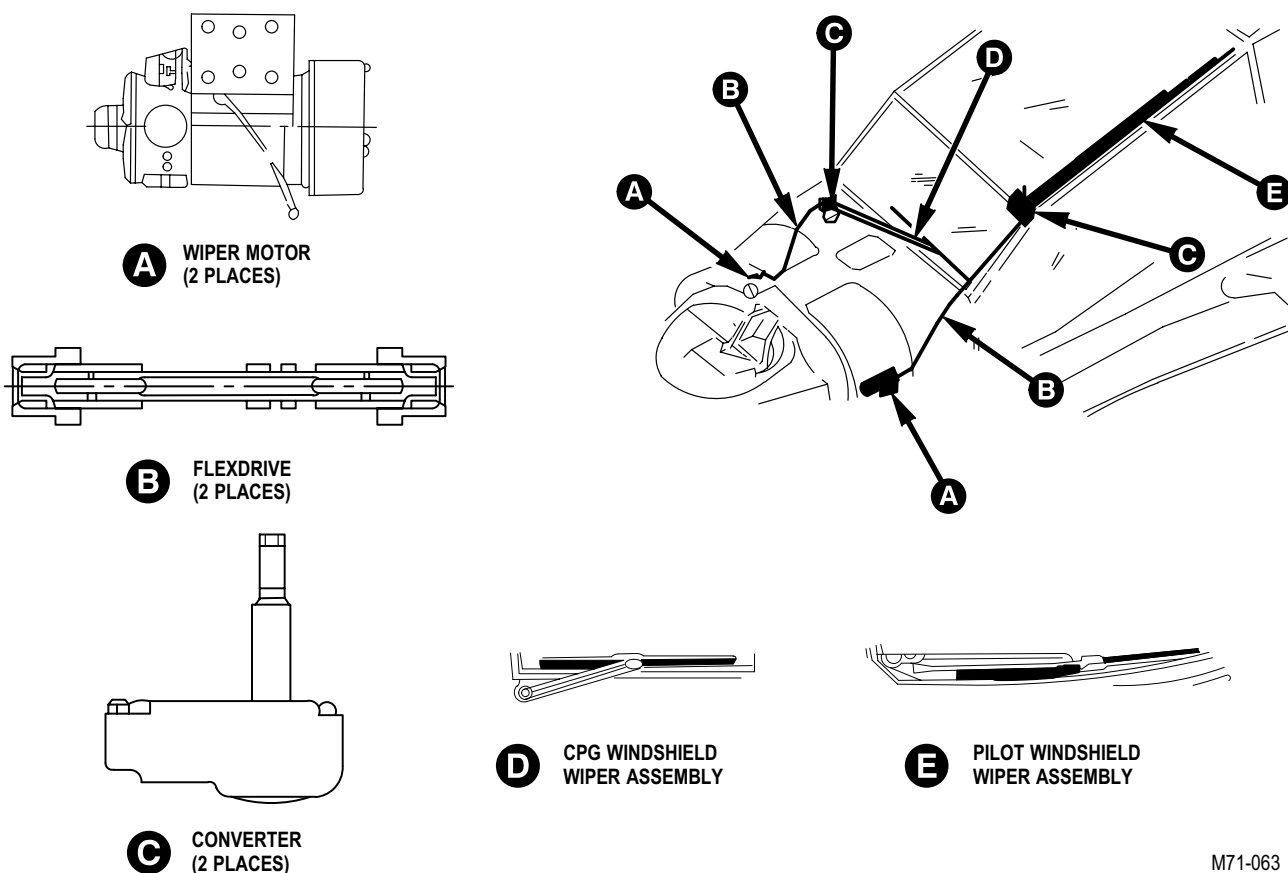

M71-063

**Figure 12-15. Windshield Wiper System Major Components Location**

**g. Engine 2 Fire Detection System.** The engine 2 fire detection system (fig. 12-17) consists of flame detectors and a flame detector amplifier.

(1) **Flame Detector.** The flame detector, located in the lower forward outboard section and upper aft inboard section of the engine 2 compartment, is an optical sensing device that uses photocells to produce an electrical signal when flame is detected.

(2) **Flame Detector Amplifier.** The flame detector amplifier, located on the inboard side of the engine 2 firewall in the aft equipment bay, controls circuitry for the fire warning indicators.

**h. APU Fire Detection System.** The APU fire detection system consists of flame detectors, a flame detector amplifier and fire/overheat detectors.

(1) **Flame Detector.** The flame detector (fig. 12-18), located in the upper forward and lower aft sections of the APU shroud, is an optical sensing device that uses photocells to produce an electrical signal when flame is detected.

(2) **Flame Detector Amplifier.** The flame detector amplifier, located in the aft equipment bay above the APU shroud, controls circuitry for the fire warning indicator.

(3) **Fire/Overheat Detectors.** The fire/overheat detectors (fig. 12-19), located over the main deck and on the right and left engine firewall louvers, senses fire in the APU/shaft driven compressor (SDC) area of the aft equipment bay.

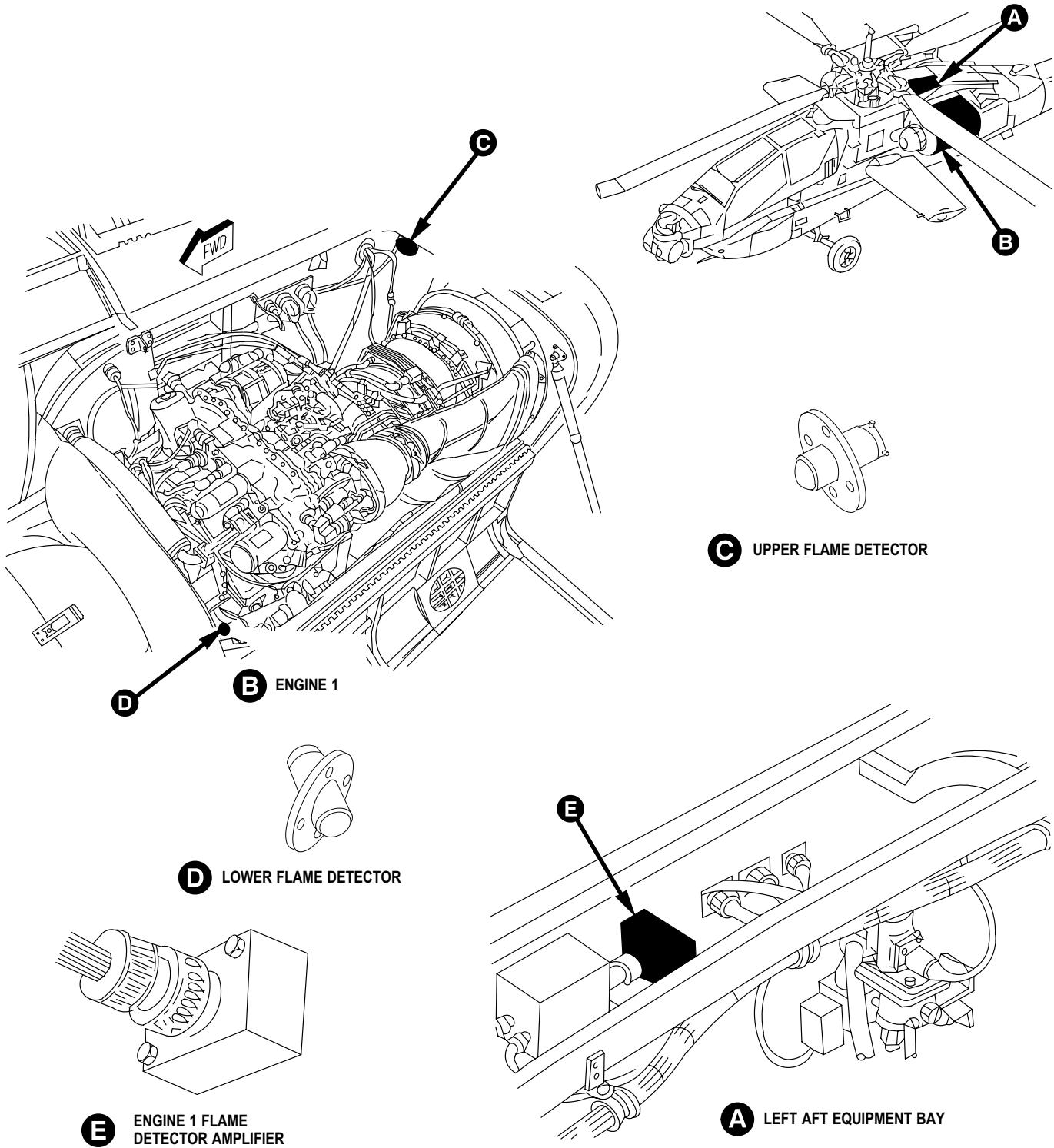

M71-075

Figure 12-16. Engine 1 Flame Detectors and Flame Detector Amplifiers Location



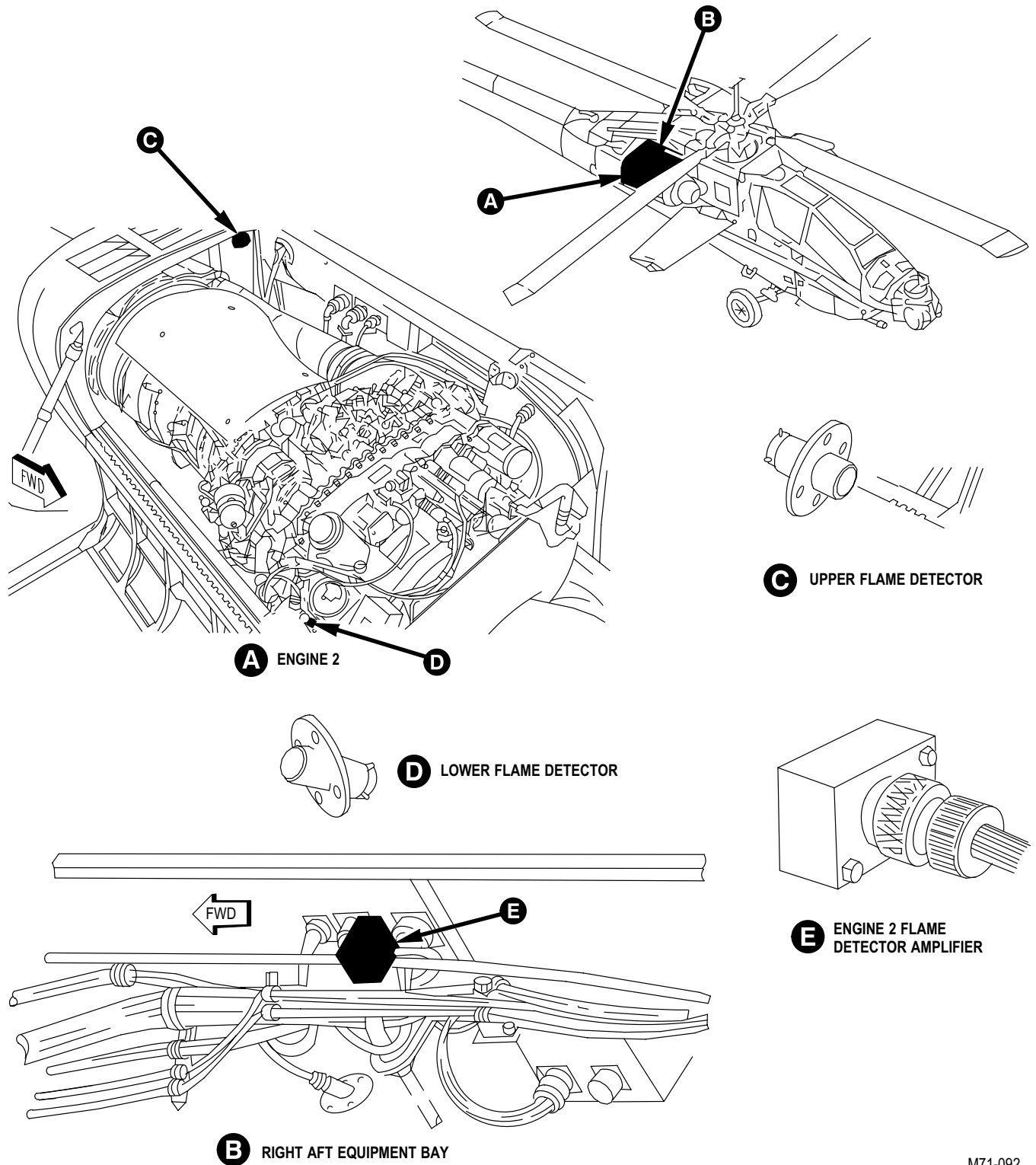

M71-092

Figure 12-17. Engine 2 Flame Detector and Flame Detector Amplifier Location

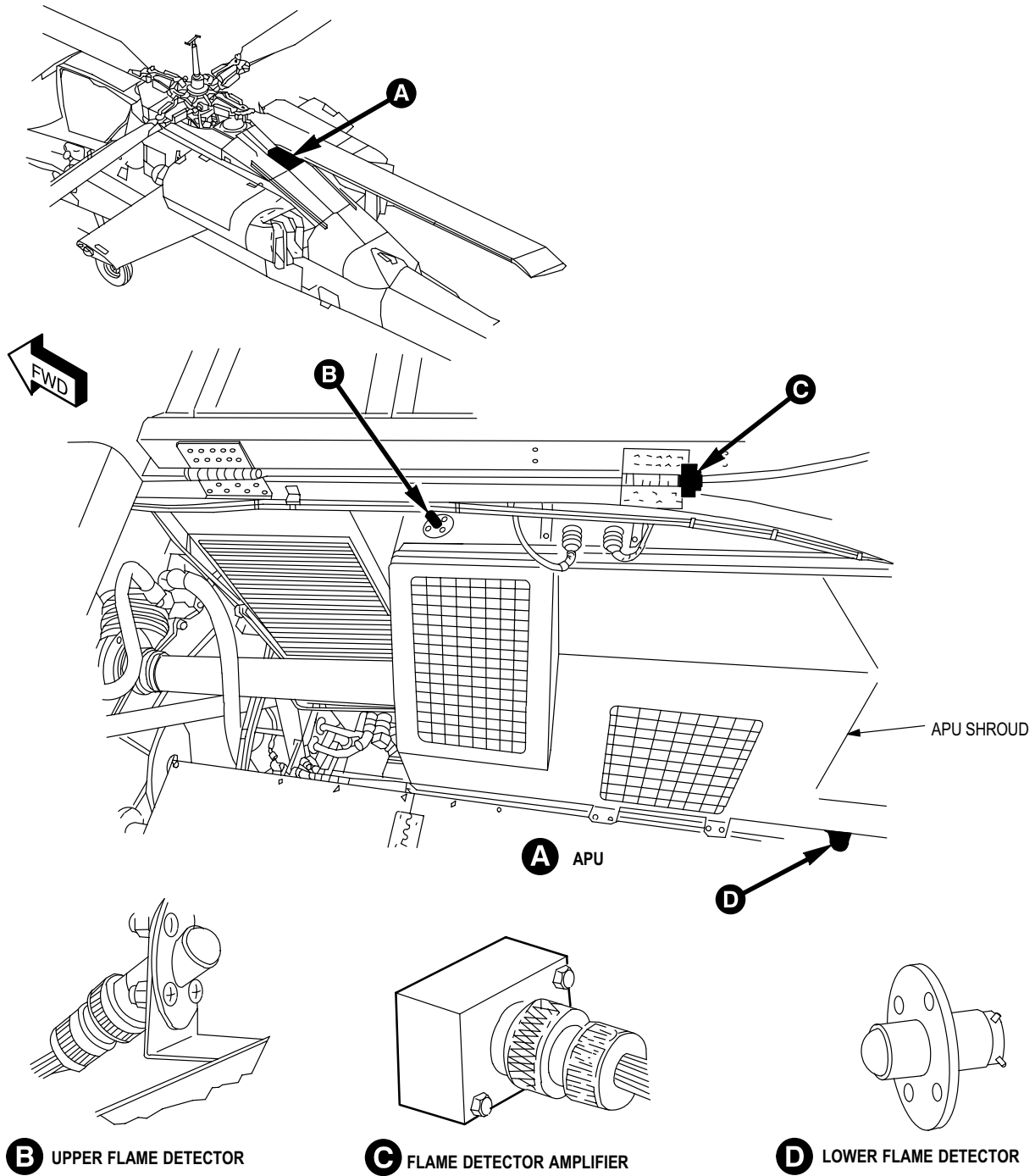

M71-107

Figure 12-18. APU Flame Detectors and Flame Detector Amplifier Location

12-2. LOCATION AND DESCRIPTION OF MAJOR COMPONENTS (cont)

12-2

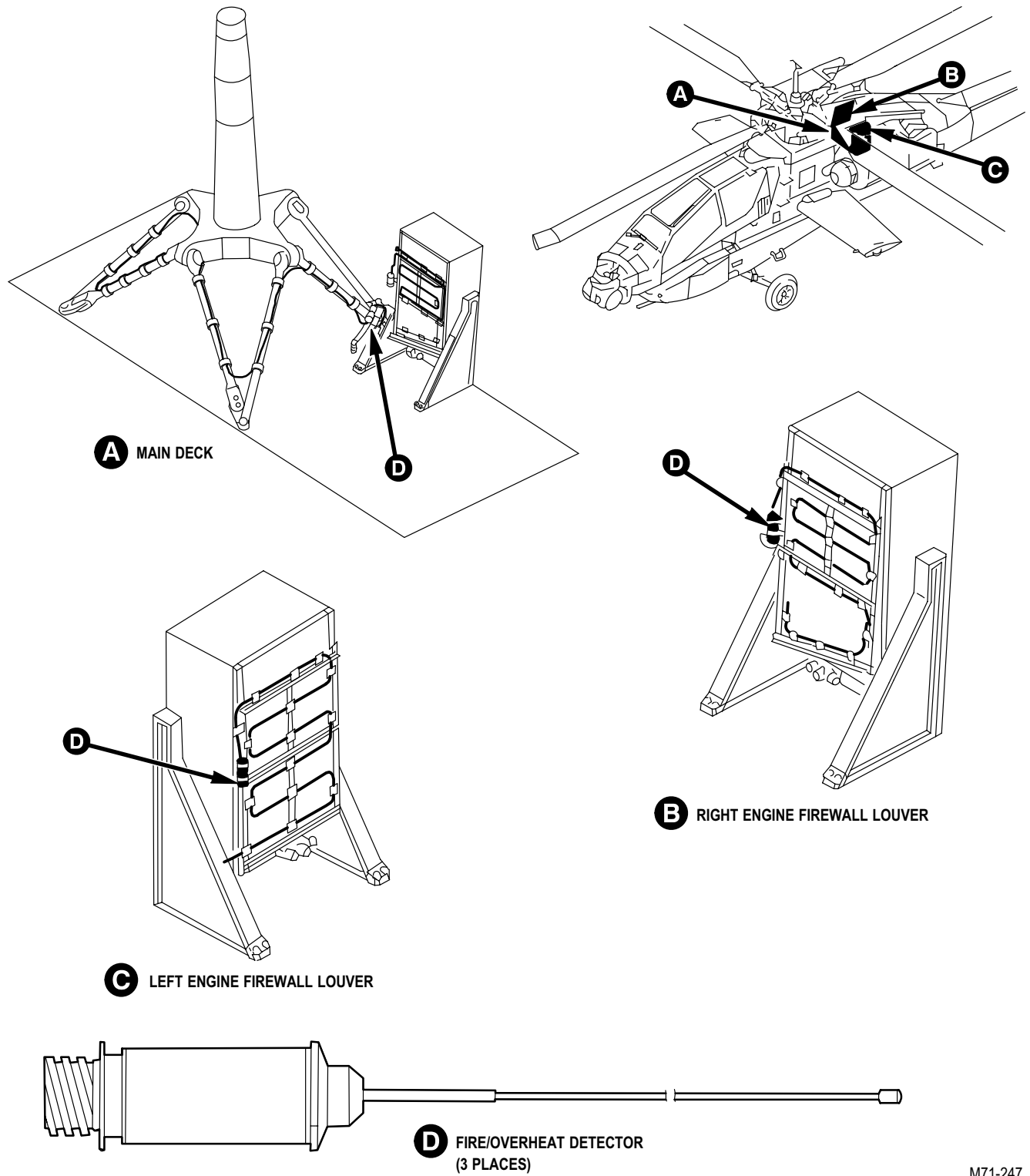

M71-247

Figure 12-19. Fire/Overheat Detectors Location

i. **Fire Extinguishers System.** The fire extinguishers system consists of primary and reserve fire bottle assemblies and a fire bottle thermal discharge indicator.

(1) **Primary Fire Bottle Assembly.** The primary fire bottle assembly (fig. 12-20), located in the aft equipment bay, is a corrosion resistant steel container filled with 1.5 lbs. of bromotrifluoromethane pressurized by nitrogen to 600 psi.

(2) **Reserve Fire Bottle Assembly.** The reserve fire bottle assembly, located in the aft equipment bay on the left firewall, is identical to and used as a backup for the primary fire bottle assembly.

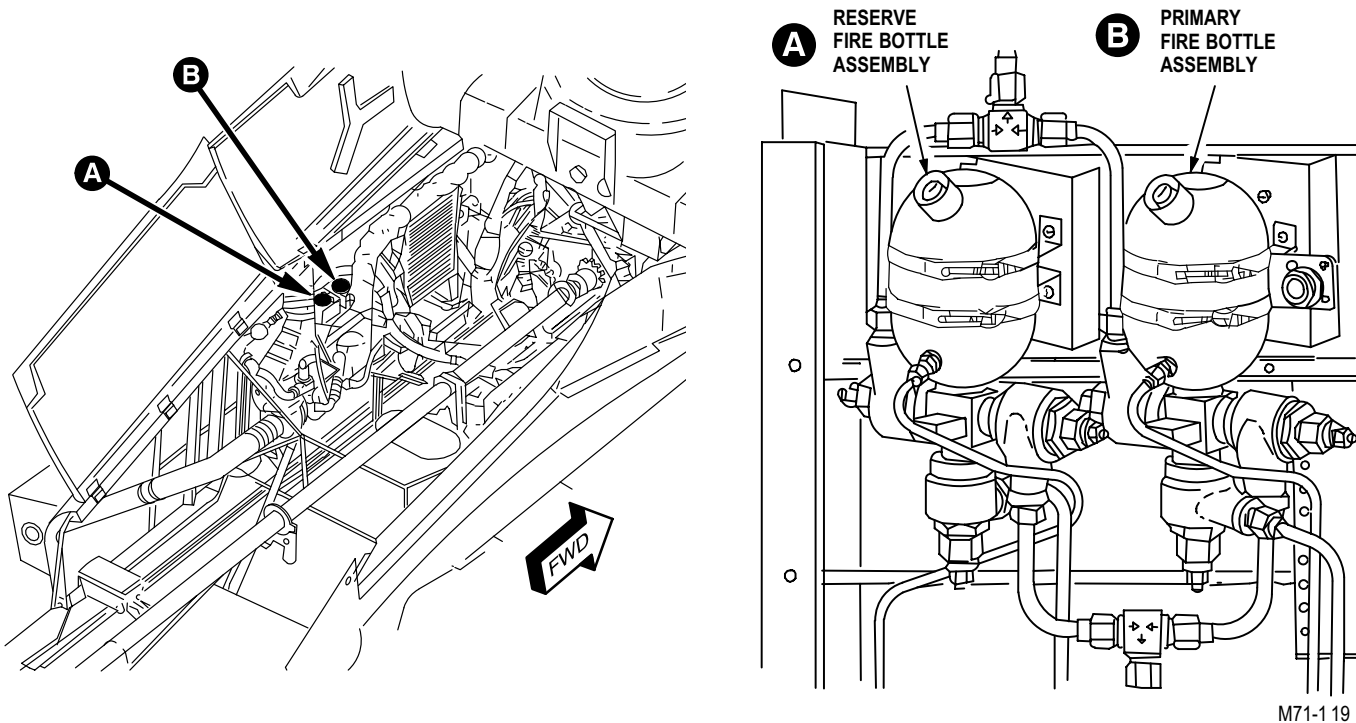

M71-119

Figure 12-20. Fire Bottle Assemblies Location

(3) **Fire Bottle Thermal Discharge Indicator.** The fire bottle thermal discharge indicator (fig. 12-21), located on the left side of the fuselage beneath engine 1, is a yellow disk that is discarded when the temperature in either fire bottle reaches 215° to 226° F (102° to 108° C).

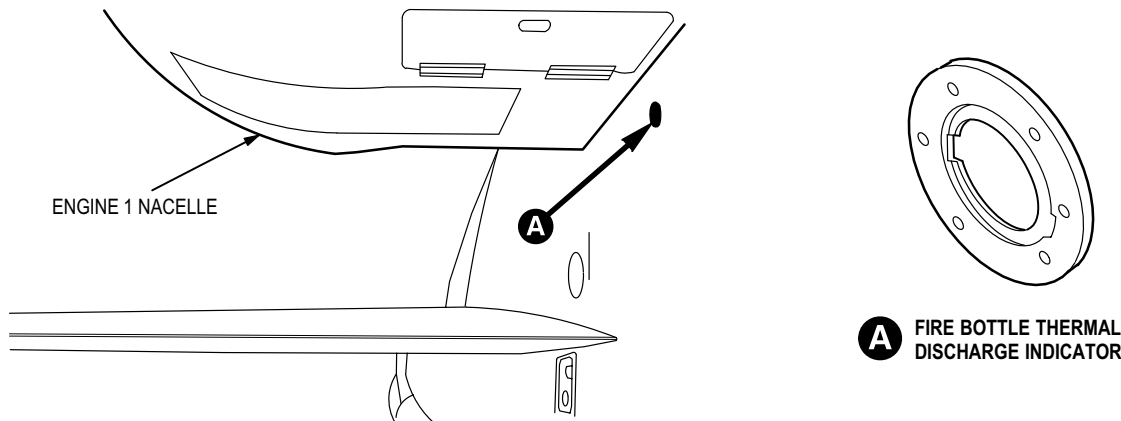

M71-120

Figure 12-21. Fire Bottle Thermal Discharge Indicator Location

**12-3. EQUIPMENT DATA**

**12-3**

Not applicable.

**12-4. EQUIPMENT CONFIGURATION**

**12-4**

Not applicable.

**12-5. SAFETY, CARE AND HANDLING OF EQUIPMENT**

**12-5**

Not applicable.

**12-6. CONTROLS AND INDICATORS**

**12-6**

The utility system receives mode selects and remote switch inputs from various controls located within the pilot station (fig. 12-22) and CPG station (fig. 12-23). Table 12-1 provides a listing of the controls, switches and associated indicators pertaining to the utility system along with a description of their function.

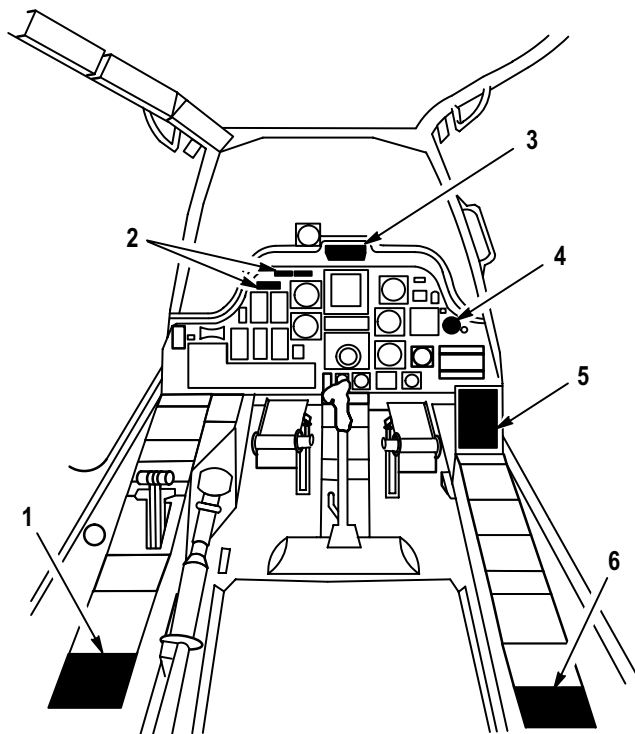

1. PILOT ANTI ICE PANEL
2. PILOT FIRE EXTINGUISHER PANEL
3. PILOT MASTER CAUTION/WARNING PANEL
4. PILOT ICING SEVERITY METER
5. PILOT CAUTION/WARNING PANEL
6. PILOT APU FIRE TEST PANEL

M71-005A

**Figure 12-22. Pilot Station**

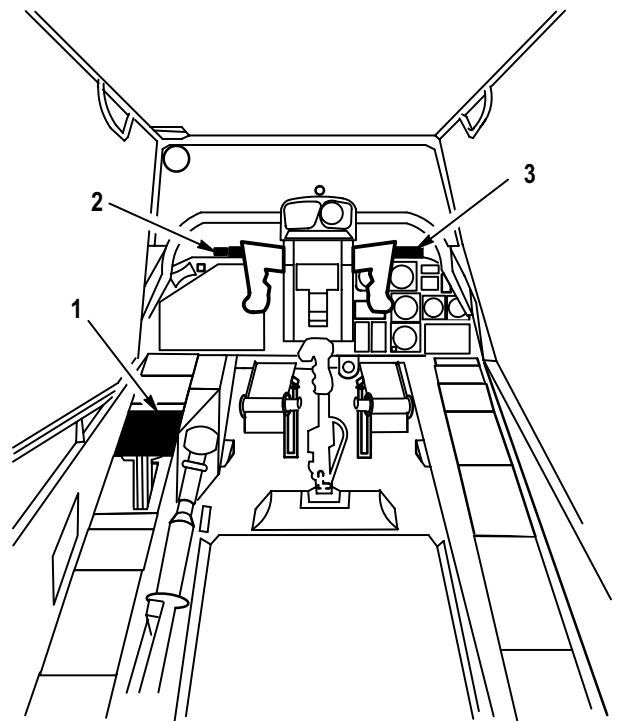

1. CPG AUX/ANTI - ICE PANEL
2. CPG GLARESHIELD FIRE EXTINGUISHER PANEL
3. CPG MASTER CAUTION/WARNING PANEL

M71-006A

**Figure 12-23. CPG Station**

*Table 12-1. Utility System Controls and Indicators*

Pilot ANTI ICE Panel		
SWITCH/INDICATOR	POSITION	FUNCTION
TADS/PNVS switch	<b>GND</b>	Energizes heating elements in the TADS/PNVS windows while the helicopter is on the ground.
	<b>ON</b>	Energizes heating elements in the TADS/PNVS windows while the helicopter is airborne.
	<b>OFF</b>	De-energizes heating elements.
DEFOG switch	<b>ON</b>	Opens canopy defog shutoff valve.
	<b>OFF</b>	Closes canopy defog shutoff valve.
HTR switch	<b>ON</b>	Energizes heating elements in the pilot and CPG windshields.
	<b>OFF</b>	De-energizes heating elements.
PITOT ICE DET AD SNSR switch	<b>ON</b>	Energizes pitot tube heater and the ice detector relay (K5-10), which provides 115 VAC and PAS air to the blade de-ice sensor.
	<b>OFF</b>	De-energizes pitot heater and the ice detector relay.
BLADE ON indicator	GREEN	Lights when power is applied to the rotor de-ice heating elements.
AUTO/TRACE/LT/MOD switch	<b>AUTO</b>	Activates automatic blade de-icing.
	<b>TRACE</b>	Activates manual mode for trace icing conditions.
	<b>LT</b>	Activates manual mode for light icing conditions.
	<b>MOD</b>	Activates manual mode for moderate icing conditions.
WSHLD WIPER switch	<b>PARK</b>	Stops windshield wipers in the stowed position.
	<b>OFF</b>	De-energizes windshield wipers.
	<b>LOW</b>	Enables windshield wipers to operate at low speed.
	<b>HIGH</b>	Enables windshield wipers to operate at high speed.
ENGINE INLET ON/OFF switch	<b>ON</b>	Removes 28 VDC from the engine anti-ice and start bleed valve (allows hot air to enter engine inlets). Applies 28 VDC to both NGB heater control units (activates NGB heater blankets).
	<b>OFF</b>	Applies 28 VDC to close the engine anti-ice and start bleed valve and the engine inlet anti-ice valve.
ON/OFF/TEST switch	<b>ON</b>	Energizes blade anti-ice system.

Table 12-1. Utility System Controls and Indicators (cont)

Pilot ANTI ICE Panel (cont)		
SWITCH/INDICATOR	POSITION	FUNCTION

<b>ENG INLET ENG 1 and ENG 2</b> indicators	<b>GREEN</b>	Lights when the engine and NGB anti-icing system is operating properly.
<b>ON/OFF/TEST</b> switch	<b>OFF</b>	De-energizes blade anti-ice system.
	<b>TEST</b>	Activates blade anti-ice system test.

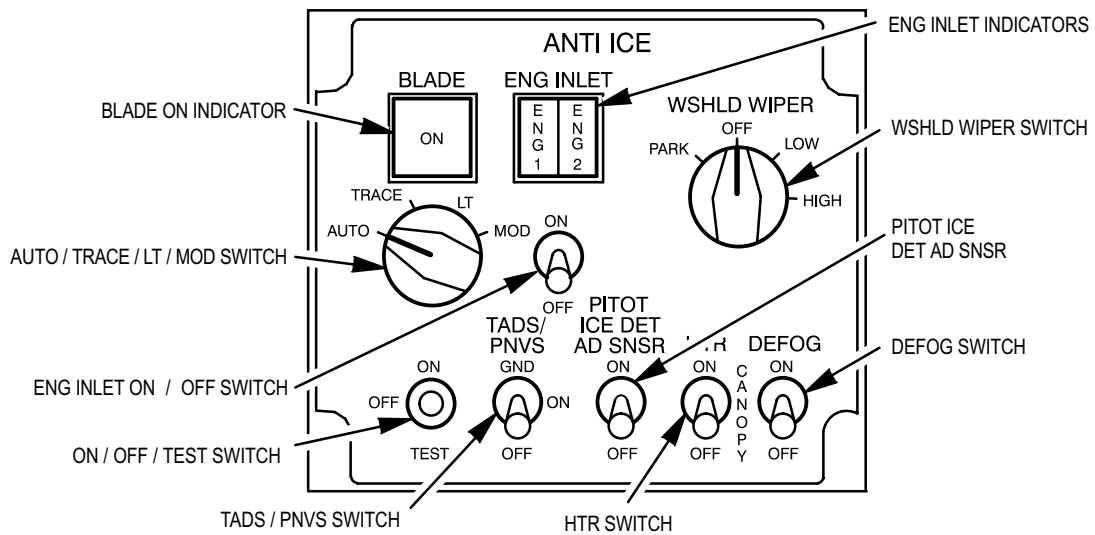

M71-007A

Pilot ANTI ICE Panel

CPG AUX/ANTI-ICE Panel		
SWITCH/INDICATOR	POSITION	FUNCTION

<b>TADS/PNVS</b> switch	<b>GND</b>	Energizes heating elements in the TADS/PNVS windows while the helicopter is on the ground.
	<b>ON</b>	Energizes heating elements in the TADS/PNVS windows while the helicopter is airborne.
	<b>OFF</b>	De-energizes heating elements.
<b>W WIPER</b> switch	<b>CPG</b>	Enables CPG windshield wipers to operate at low speed regardless of pilot <b>WSHLD WIPER</b> switch position.
	<b>PILOT</b>	Enables pilot to control windshield wiper system.

Table 12-1. Utility System Controls and Indicators (cont)

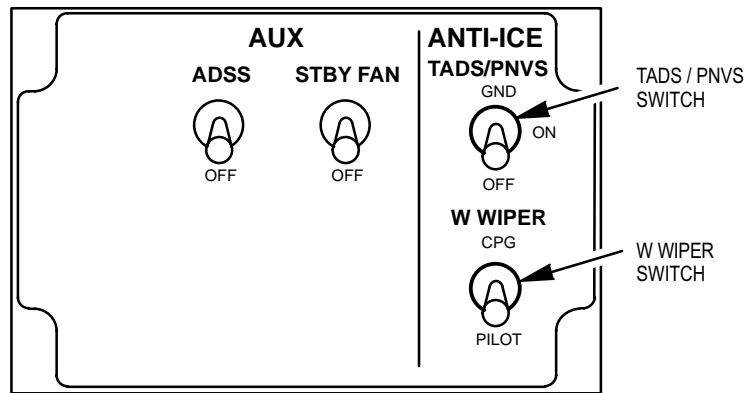

M71-008A

CPG AUX/ANTI-ICE Panel

Pilot Caution/Warning Panel		
SWITCH/INDICATOR	POSITION	FUNCTION

<b>BLADE ANTI ICE FAIL</b> indicator	AMBER	Lights when the rotor blades de-ice system fails.
<b>ENG ICE</b> indicator	AMBER	Lights when ice has been detected by the ice detector sensor.
<b>ENG 1/ENG 2 ANTI ICE</b> indicator	AMBER	Lights when the <b>ANTI ICE ON/OFF</b> switch is set to the <b>ON</b> position, the <b>ENG 1</b> and <b>ENG 2 ANTI ICE</b> indicators light until the respective anti-ice bleed air temperature switch senses 155° F (68° C).
<b>CANOPY ANTI ICE FAIL</b> indicator	AMBER	Lights when the canopy anti-ice system fails.

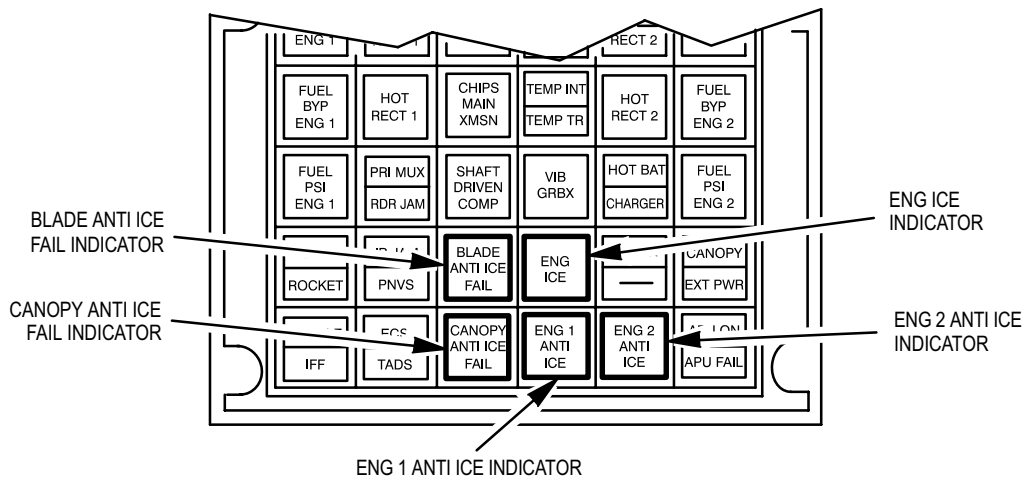

M71-053A

Pilot Caution/Warning Panel



12-6. CONTROLS AND INDICATORS (cont)

12-6

Table 12-1. Utility System Controls and Indicators (cont)

Icing Severity Meter		
SWITCH/INDICATOR	POSITION	FUNCTION

**LWC g/m<sup>3</sup>** pointer

Indicates degree of icing.

**LWC PRESS TO TEST**  
pushbutton

Press to move pointer to the 1.5 mark for testing.

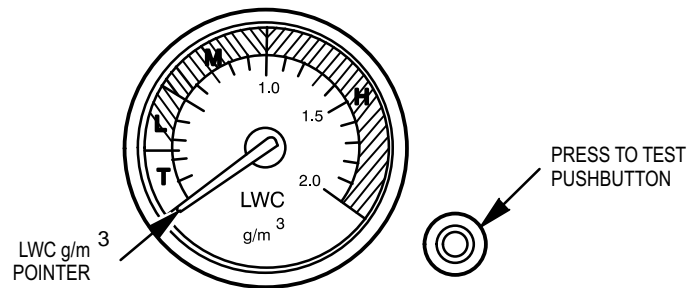

M71-054

Icing Severity Meter

Pilot Fire Extinguisher Panel		
SWITCH/INDICATOR	POSITION	FUNCTION

**ENG 1 FIRE PULL** handle

RED

Lights when fire exists in engine 1 compartment.

Pulled

Arms the appropriate firing squib circuit, closes engine 1 fuel crossfeed valve, closes engine 1 louvers and closes the environmental control system (ECS) shutoff valve.

**ENG 2 FIRE PULL** handle

RED

Lights when fire exists in engine 2 compartment.

Pulled

Arms the appropriate firing squib circuit, closes engine 2 fuel crossfeed valve, closes engine 2 louvers and closes the ECS shutoff valve.

**FIRE BTL** switch

**PRI**

Fires the squib on the primary fire bottle, releasing the extinguishing agent.

Center

De-energizes fire bottles.

**RES**

Fires the squib on the reserve fire bottle, releasing the extinguishing agent.

Table 12-1. Utility System Controls and Indicators (cont)

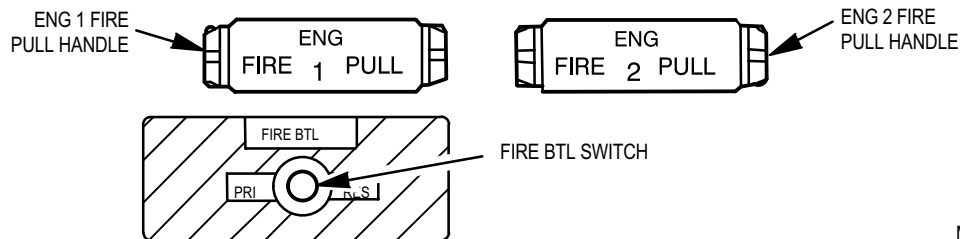

M71-078A

**Pilot Fire Extinguisher Panel**

CPG Fire Extinguisher Panel		
SWITCH/INDICATOR	POSITION	FUNCTION
<b>ENG 1 FIRE PULL</b> handle	RED	Lights when fire exists in engine 1 compartment.
	Pulled	Arms the appropriate firing squib circuit, closes engine 1 fuel crossfeed valve, closes engine 1 louvers and closes the ECS shutoff valve.
<b>ENG 2 FIRE PULL</b> handle	RED	Lights when fire exists in engine 2 compartment.
	Pulled	Arms the appropriate firing squib circuit, closes engine 2 fuel crossfeed valve, closes engine 2 louvers and closes the ECS shutoff valve.
<b>FIRE BTL</b> switch	<b>PRI</b>	Fires the squib on the primary fire bottle, releasing the extinguishing agent.
	Center	De-energizes fire bottles.
	<b>RES</b>	Fires the squib on the reserve fire bottle, releasing the extinguishing agent.

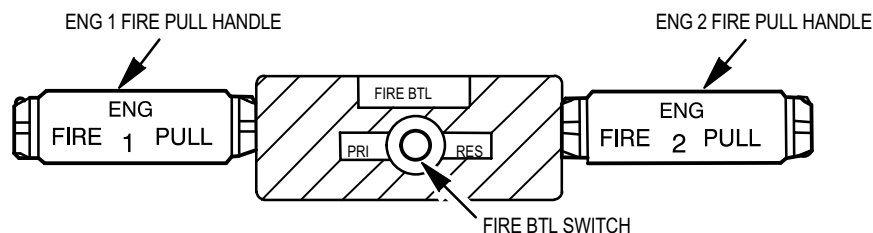

M71-079A

**CPG Fire Extinguisher Panel**

## 12-6. CONTROLS AND INDICATORS (cont)

12-6

Table 12-1. Utility System Controls and Indicators (cont)

Pilot APU Fire Test Panel		
SWITCH/INDICATOR	POSITION	FUNCTION
<b>FIRE TEST DET</b> switch	<b>OFF</b>	De-energizes fire detection test circuitry.
	<b>1</b>	Lights pilot and CPG <b>ENG 1 FIRE PULL, ENG 2 FIRE PULL, APU FIRE PULL</b> handles and <b>FIRE APU</b> master caution indicators during operation of the engine upper flame detectors, the upper APU flame detector, and the left and right firewall louver door fire detector circuits and components.
	<b>2</b>	Lights pilot and CPG <b>ENG 1 FIRE PULL, ENG 2 FIRE PULL, APU FIRE PULL</b> handles and <b>FIRE APU</b> master caution indicators during operation of the engine lower flame detectors, the lower APU flame detector, main transmission support fire detector circuits and components.
<b>APU FIRE PULL</b> handle	<b>DET</b>	Not used.
	RED	Lights when fire exists in the APU shroud.
	Pulled	Arms the appropriate firing squib circuit, closes the APU fuel valve.
<b>FIRE BTL</b> switch	<b>PRI</b>	Fires the squib on the primary fire bottle, releasing the extinguishing agent.
	Center	De-energizes fire bottles.
	<b>RES</b>	Fires the squib on the reserve fire bottle, releasing the extinguishing agent.
<b>PRI DISCH</b> indicator	GREEN	Lights when the primary fire bottle has discharged.
<b>RES DISCH</b> indicator	GREEN	Lights when the reserve fire bottle has discharged.

Table 12-1. Utility System Controls and Indicators (cont)

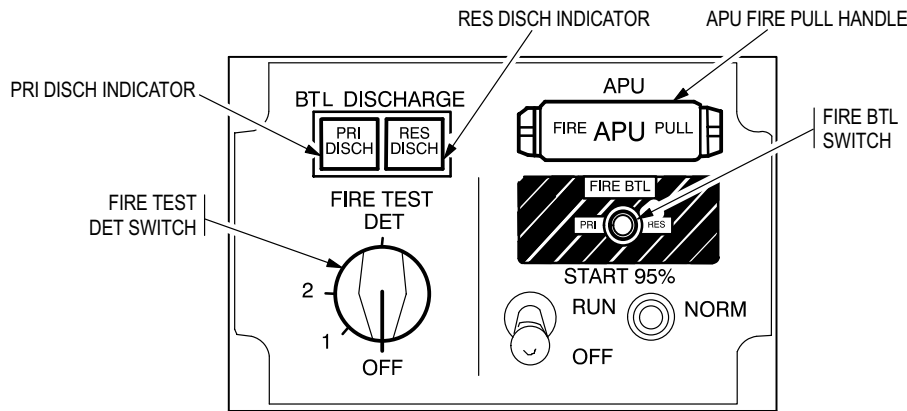

M71-080A

Pilot APU Fire Test Panel

Pilot/CPG Master Caution/Warning Panels		
SWITCH/INDICATOR	POSITION	FUNCTION

<b>PRESS TO TEST</b> switch	WHITE	Lights master caution/warning panel indicators, caution/warning panel indicators, <b>FIRE PULL</b> handles, <b>APU FIRE PULL</b> handle and <b>FIRE APU</b> indicator for test.
<b>FIRE APU</b> indicator	RED	Lights when fire exists in the APU shroud or when the fire/overheat detector senses overtemp condition in the mast base support strut area and the engine firewall louvers.

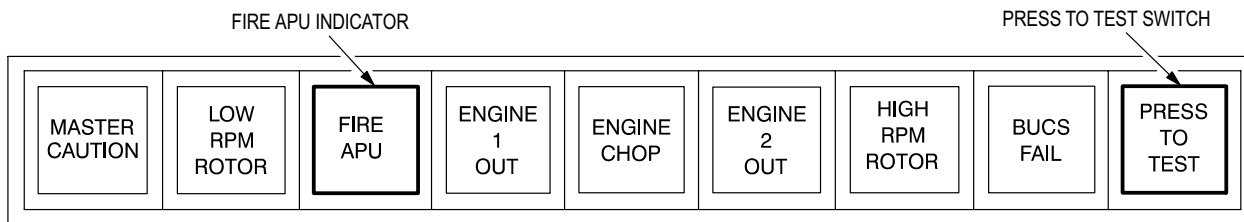

M71-215A

Master Caution/Warning Panel

## SECTION II. THEORY OF OPERATION

### 12-7. SYSTEM DESCRIPTION

12-7

a. **Utility System.** The utility system (fig. 12-24) consists of the canopy defog and anti-ice system, engine anti-ice system, pitot anti-ice system, rotor blades de-ice system, windshield wipers, fire detection and extinguishing system, and the canopy jettison system.

(1) The canopy anti-ice system heats the canopy panels to prevent or remove ice build-up. When the temperature decreases, the heaters are switched on to provide uniform windshield heating. System control is located on the pilot **ANTI ICE** panel. A failure in the system lights the **CANOPY ANTI ICE FAIL** indicator on the pilot caution/warning panel. The TADS/PNVS anti-ice system prevents the formation of ice on the PNVS window and on the TADS system day, night, and boresight module windows. The controls for the system are on the pilot **ANTI ICE** panel and the CPG **AUX/ANTI-ICE** panel. The system is disabled on the ground by the squat switch and a ground test function is available. The canopy defog system removes fog from the inside of the crew canopies. Control for this system is on the pilot **ANTI ICE** panel; the CPG does not have control of the defog system. When the system is operating, the hot air is mixed with the crew station conditioned air to partially cool it before it is directed against the side panels to defog them.

(2) The engine anti-ice system prevents ice build-up on the NGB fairings and in the engine inlet area. The control is located on the pilot **ANTI ICE** panel. Operation of the system is automatic when the switch is set to **ON**. The NGB heater blanket is electrically heated and the engine inlet is heated with bleed air from the engine itself, both of which try to maintain a constant temperature in their respective areas. The pilot **ANTI ICE** panel contains two green lights, labeled **ENG INLET ENG 1** and **2** to indicate that the system is operating. The pilot and CPG caution/warning panels contain the **ENG ICE** indicators, which light when the ice detector senses ice. The **ENG 1** and **ENG 2 ANTI ICE** indicators light when the engine anti-ice system malfunctions (lights momentarily when engine anti-ice system is switched on until the engine thermal switches sense 155° F (68° C)).

(3) The pitot and ADS anti-ice systems prevent ice from forming on the pitot tubes and the air data sensor. The controls are the **PITOT/ICE DET/AD SNSR** switch on the pilot **ANTI ICE** panel and the **ADSS** switch on the CPG **AUX/ANTI-ICE** panel. The pitot tubes, ice detector sensor, and the omnidirectional airspeed sensor (OAS) have internal heaters.

(4) The rotor blade de-ice system provides main and tail rotor ice removal during light to moderate icing conditions. The operating controls are on the pilot **ANTI ICE** panel. The system contains an OAT sensor and a rotor blade de-ice controller that vary the main and tail rotor heater "on" time as required. The ice detector sensor sends a signal proportional to the amount of ice present to the ice detector signal processor to initiate the de-ice sequence through the rotor blade de-ice controller. The icing severity meter is driven by the ice detector signal processor. There is a press-to-test function on the icing severity meter. The main and tail rotor heater blankets are internally bonded to the blades to ensure uniform heating. A failure of the rotor blade de-ice system causes the **BLADE ANTI ICE FAIL** indicator on the pilot caution/warning panel to light. The **BLADE ON** indicator on the pilot **ANTI ICE** panel advises the pilot that the system is operating.

(5) The windshield wipers remove moisture from the pilot and CPG windshields. The 2 speed windshield wipers can be fully controlled from the pilot station and partially controlled from the CPG station. The controls are located on the pilot **ANTI ICE** panel and on the CPG **AUX/ANTI-ICE** panel. The windshield wiper motors are located in the left and right nose equipment bays and they drive the windshield wiper assemblies by means of a flexible driveshaft through a converter.

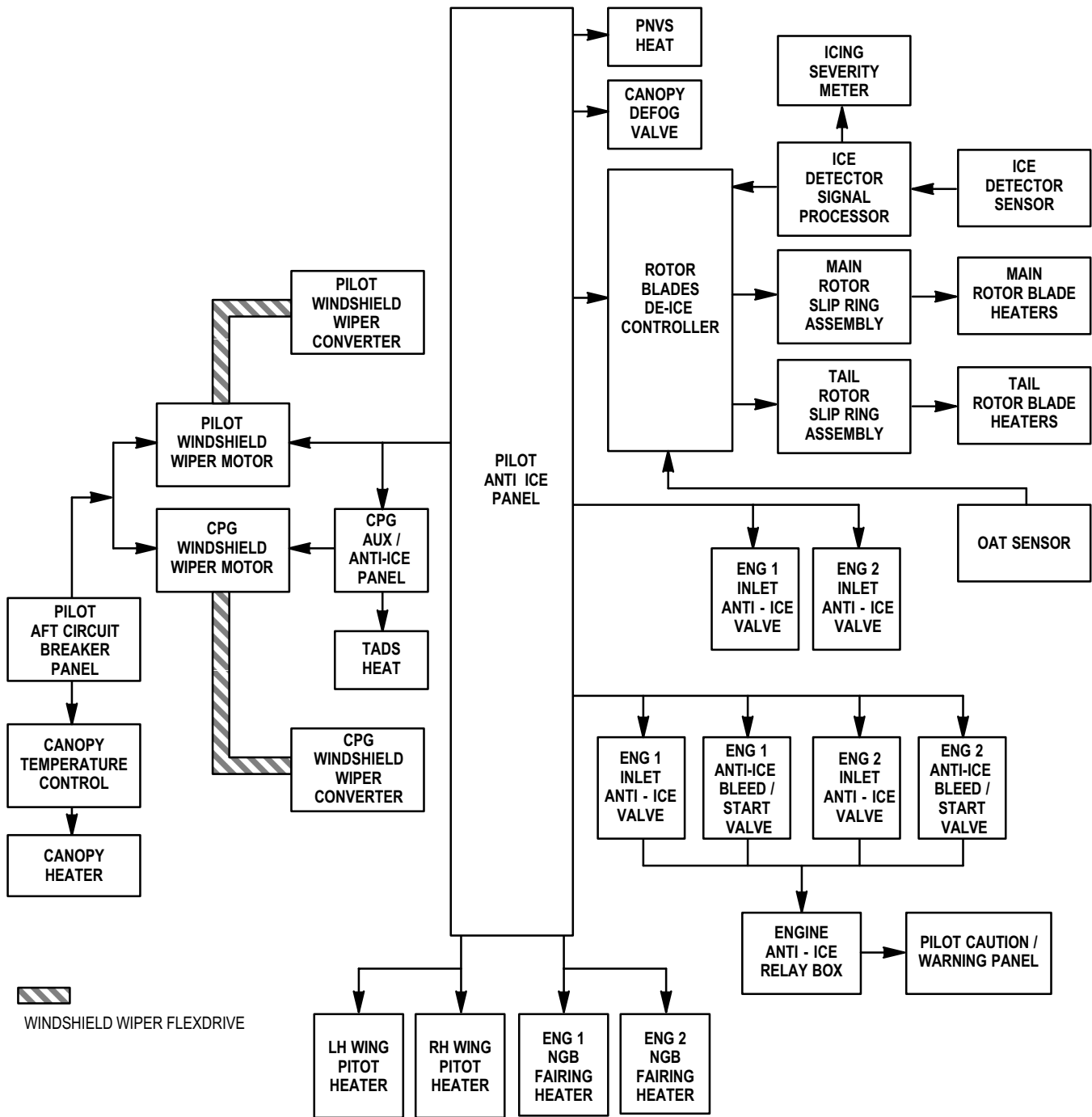

M71-313

Figure 12-24. Utility System Functional Block Diagram

---

**12-7. SYSTEM DESCRIPTION (cont)**

---

12-7

(6) The fire detection and extinguishing system (fig. 12-25) detects and extinguishes fires in the engine and APU compartments. Optical flame detectors detect flames in the engine compartments and send a signal to the flame detector amplifier which lights the respective **FIRE PULL** handle. There are two fire bottle assemblies containing pressurized chemical fire extinguishing agent that can be discharged into either engine nacelle or the APU compartment. The bottles contain a squib cartridge to discharge the agent and are equipped with a pressure relief valve for over-temperature protection. The system is controlled by the **FIRE PULL** handles and the **FIRE BTL** select switches on the pilot and CPG instrument panels and the pilot **APU** fire test panel, located on the pilot's right-hand console. A test function is controlled from the pilot **APU** fire test panel. The discharge indicator, located on the left side of the fuselage beneath the engine compartment, gives a visual indication of bottle discharge due to excessive temperature.

(7) The canopy jettison system (fig. 12-26) provides emergency egress for the crew members by jettisoning the large acrylic panels on each side of the pilot and CPG (4 total). The system is controlled by **CANOPY JETTISON** handles on the upper left pilot and CPG instrument panels and under access door T-50. Activating one of the handles detonates an explosive cartridge which ignites the shielded mild detonation cord (SMDC) which burns to the flexible confined detonating cord (FCDC) around the periphery of the canopy panel. The panel then falls out or is pushed out, providing an egress path. The system is safed on the ground by a safety pin in each jettison handle.

**b. Canopy Defog and Anti-Ice System.**

(1) **Purpose.** The purpose of the canopy defog system is to remove fog from the inside of the crew station canopy. The purpose of the anti-ice system is to prevent the formation of ice on the crew station canopy and the windshield panels.

**(2) System Operation.**

(a) The canopy defog system (fig. 12-27) is enabled when the **CANOPY DEFOG** switch on the pilot **ANTI ICE** panel is placed in the **ON** position. **ECS CANOPY ANTI-ICE CONTR** circuit breaker (CB70) supplies 28 VDC to the defog shutoff valve and is energized open. The canopy side panels are defogged by hot pressurized air passing through the defog shutoff valve, mixing with cabin air, and is directed against the canopy side panels.

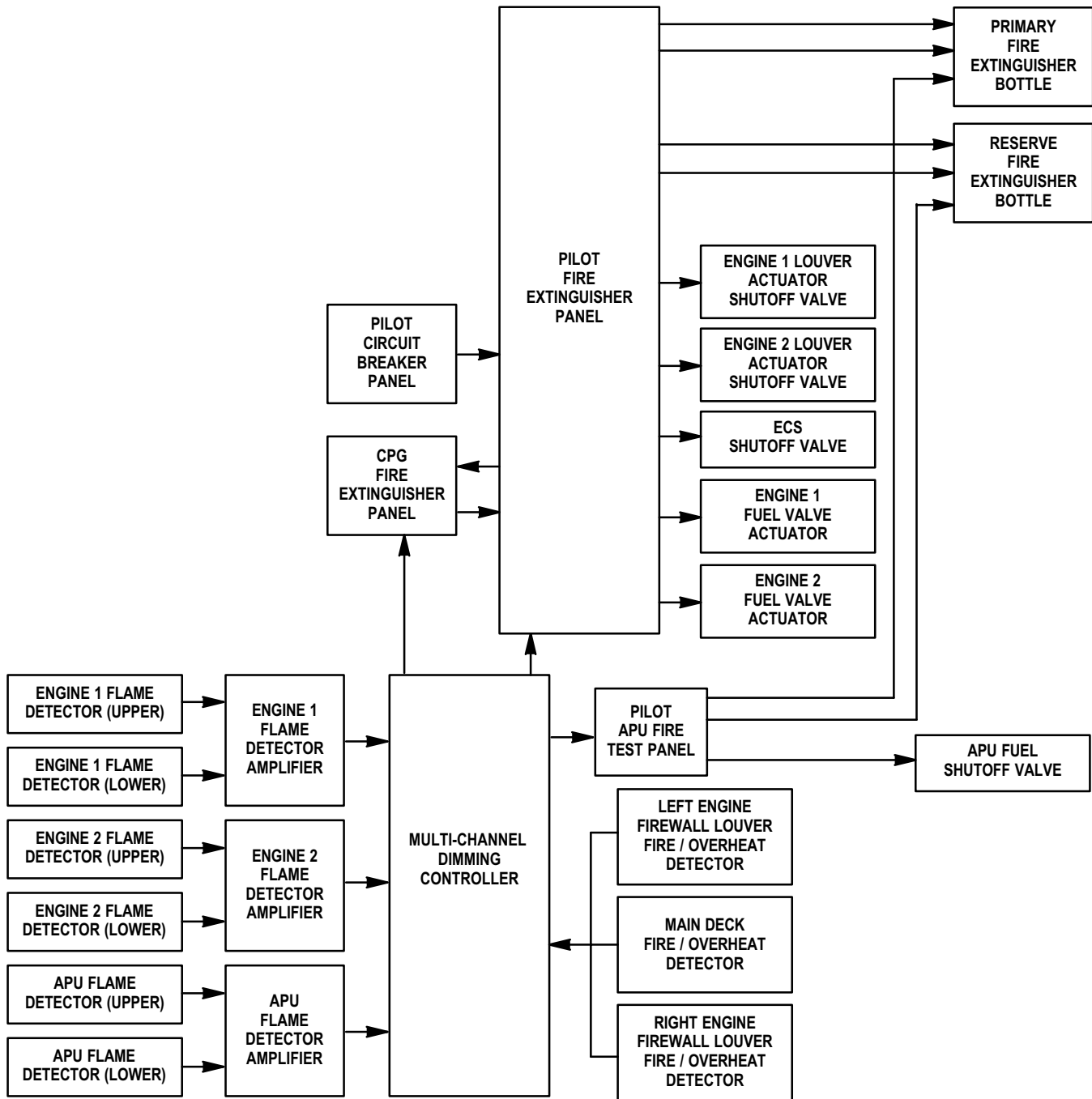

M71-315

Figure 12-25. Fire Detection/Extinguishing System Functional Block Diagram



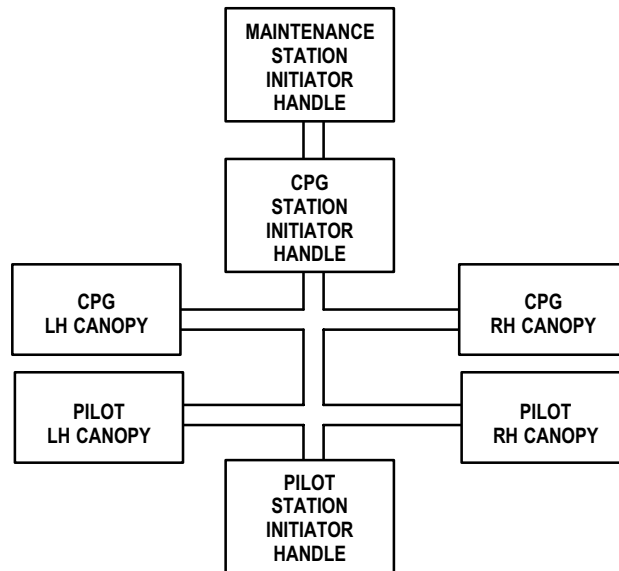

M71-314

Figure 12-26. Canopy Jettison System

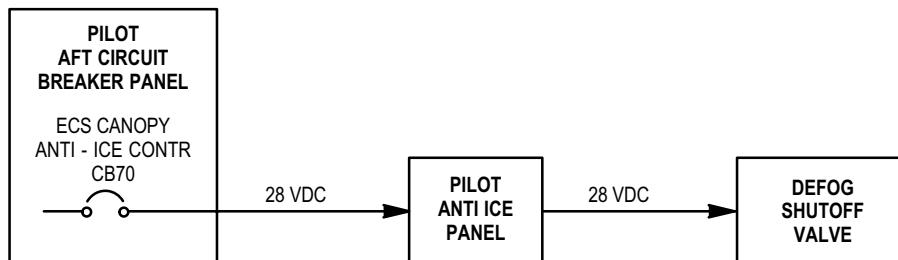

M71-224

Figure 12-27. Canopy Defog Block Diagram

(b) The canopy anti-ice system (fig. 12-28) is enabled when the **CANOPY HTR** switch on the pilot **ANTI ICE** panel is placed in the **ON** position. **ECS CANOPY ANTI-ICE CONTR** circuit breaker (CB70) supplies 28 VDC to the canopy temperature control. The canopy temperature control monitors and controls the application of 115/200 VAC 3-phase power supplied by **ECS CANOPY ANTI-ICE** circuit breaker (CB78) to the canopy heater. The 115/200 VAC 3-phase power is applied to heating elements in the canopy windshields and canopy temperature is sensed by a temperature sensor. The temperature sensor provides feedback to the canopy temperature control, which maintains windshield temperature between 65° F and 85° F (18° C and 30° C).

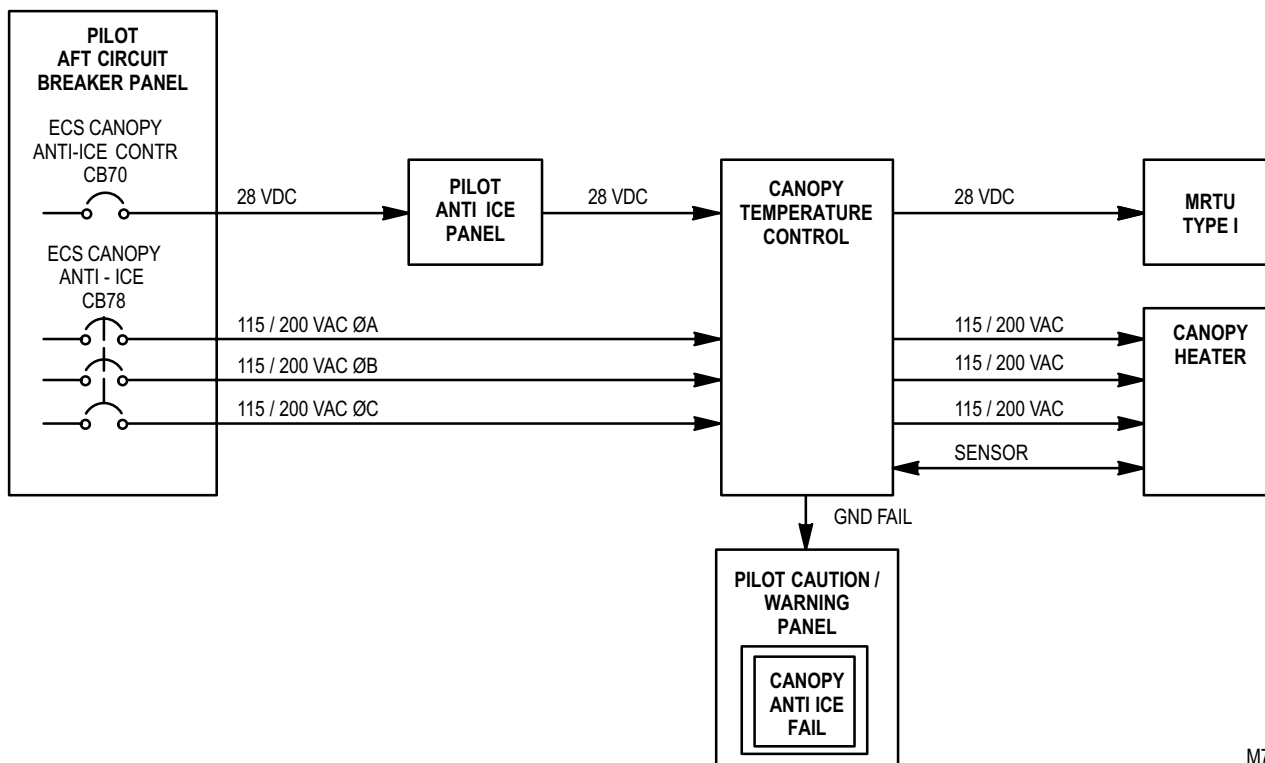

Figure 12-28. Canopy Anti-Ice Functional Block Diagram

(c) If the canopy overheats or the temperature sensor fails, the temperature control unit removes power from the canopy heater. The temperature control unit also monitors the heating elements, input power, and itself. In event of a failure, the canopy temperature control generates a low signal output lighting the **CANOPY ANTI-ICE FAIL** indicator on the pilot caution/warning panel and to the fire control computer (FCC) through the multiplex remote terminal unit (MRTU) type I for use with the maintenance fault detection and location system (FD/LS).

(d) The PNVS anti-ice system (fig. 12-29) is enabled in the air when the **TADS/PNVS** switch on the pilot **ANTI ICE** panel or **CPG AUX/ANTI-ICE** panel is placed in the **ON** position. **ECS CANOPY ANTI-ICE CONTR** circuit breaker (CB70) supplies 28 VDC via the squat switch to the MRTU type I. The MRTU type I provides information to the FCC which instructs the PNVS system to enable PNVS anti-ice function.

(e) The squat switch disables the PNVS anti-ice function on the ground unless the **TADS/PNVS** switch is placed to the **GND** position. The **GND** position is used to check the system on the ground.

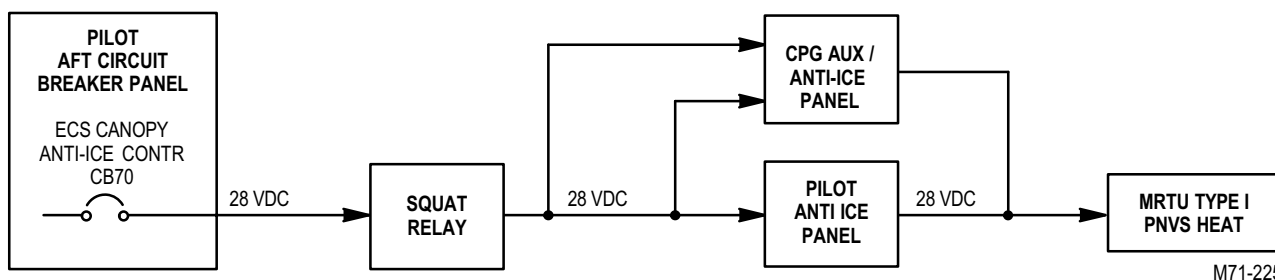

Figure 12-29. PNVS Anti-Ice Functional Block Diagram

## 12-7. SYSTEM DESCRIPTION (cont)

12-7

(f) The TADS anti-ice system (fig. 12-30) is enabled in the air when the **TADS/PNVS** switch on the pilot **ANTI ICE** panel or **CPG AUX/ANTI-ICE** panel is placed to the **ON** position. **ECS CANOPY ANTI-ICE CONTR** circuit breaker (CB70) supplies 28 VDC via the squat switch in the MRTU type III. The MRTU type III provides information to the FCC which instructs the TADS system to enable the TADS anti-ice function.

**NOTE**

The TADS and PNVS anti-ice systems will not operate (regardless of the TADS/PNVS anti-ice switch position) if the TADS and PNVS systems are not turned on.

(g) The squat switch disables the TADS anti-ice function on the ground unless the **TADS/PNVS** switch is placed in the **GND** position. The **GND** position is used to check the system on the ground.

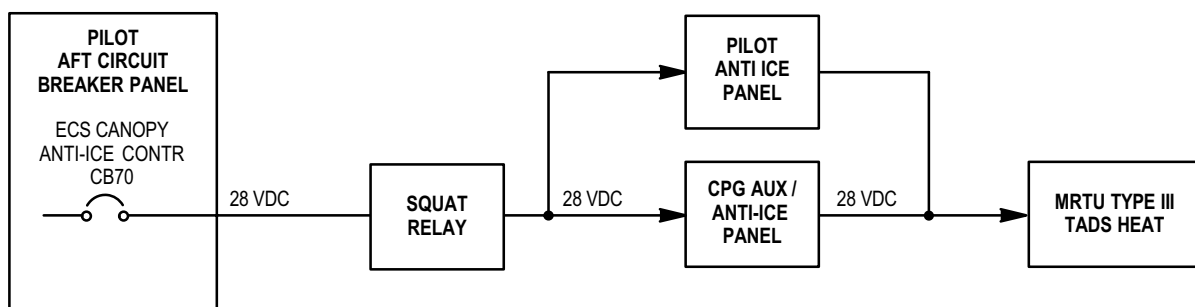

M71-226

**Figure 12-30. TADS Anti-Ice Functional Block Diagram**

**c. Engine Anti-Ice System.**

(1) **Purpose.** The purpose of the engine anti-ice system is to prevent ice build up around the NGB fairings and control anti-icing airflow to the engines.

(2) **System Operation.**

(a) When the **ENG INLET** anti-ice switch is in the **OFF** position (fig. 12-31), 28 VDC is routed to the engine 1 inlet anti-ice valve, engine 1 anti-ice bleed/start valve, engine 1 thermal switch, engine 2 inlet anti-ice valve, engine 2 anti-ice bleed/start valve, engine 2 thermal switch, and engine anti-ice relay. The engine inlet anti-ice valves and the engine anti-ice start/bleed valves are energized closed, but the engine anti-ice start/bleed valves are mechanically held open. When the engine anti-ice start/bleed valves are open, 28 VDC is supplied through the multi-channel dimming controller to the pilot **ANTI ICE** panel, lighting the **ENG 1** and **ENG 2** indicators. When engine speed increases above 91% NG the engine anti-ice start/bleed valves close and extinguish the **ENG 1** and **ENG 2** indicators. If an engine anti-ice start/bleed valve remains open, the appropriate engine indicator remains lighted. The engine thermal switches close at a duct temperature of 155° F (68° C). If either thermal switch closes and the **ENG INLET** anti-ice switch is in the **OFF** position, the appropriate **ENG 1** or **ENG 2 ANTI-ICE** indicator will light on the pilot caution/warning panel and the **ENG ANTI-ICE** indicator will light on the CPG caution/warning panel.

(b) When the **ENG INLET** anti-ice switch is in the **ON** position (fig. 12-32), 28 VDC is removed from the engine anti-ice valves. The open anti-ice bleed/start valves allow fifth stage bleed air to heat engine guide vanes, swirl vanes, and de-swirl vanes. The open inlet anti-ice valves allow fifth stage bleed air to heat the engine inlet fairings. The **ENG ANTI-ICE** indicators on the pilot and CPG caution/warning panels will momentarily light after the engine anti-ice system is switched on, until the thermal switches close at 155° F (68° C). If either thermal switch stays open (below 155° F) and the **ENG INLET** anti-ice switch is in the **ON** position, the appropriate **ENG ANTI-ICE** indicators will light.

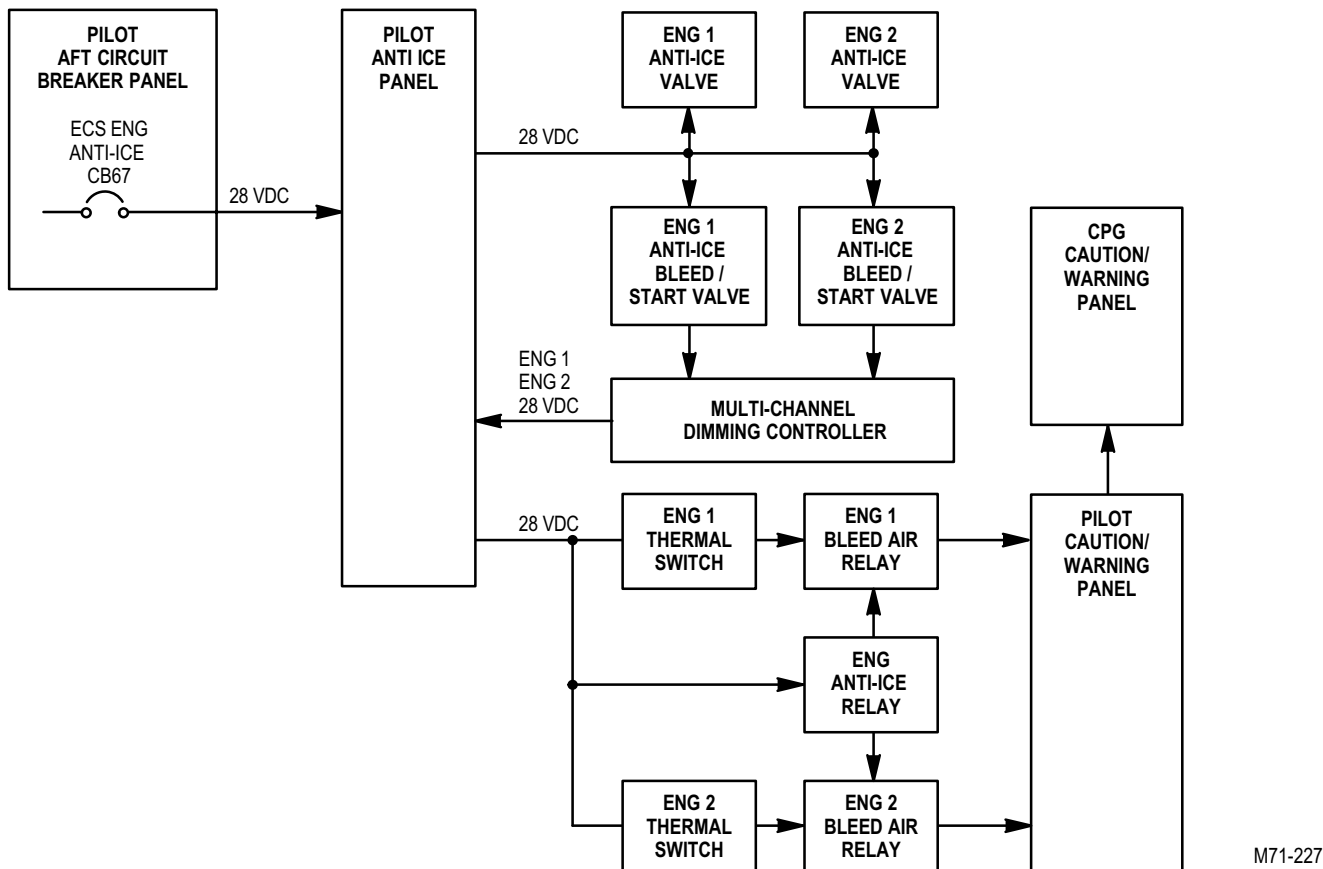
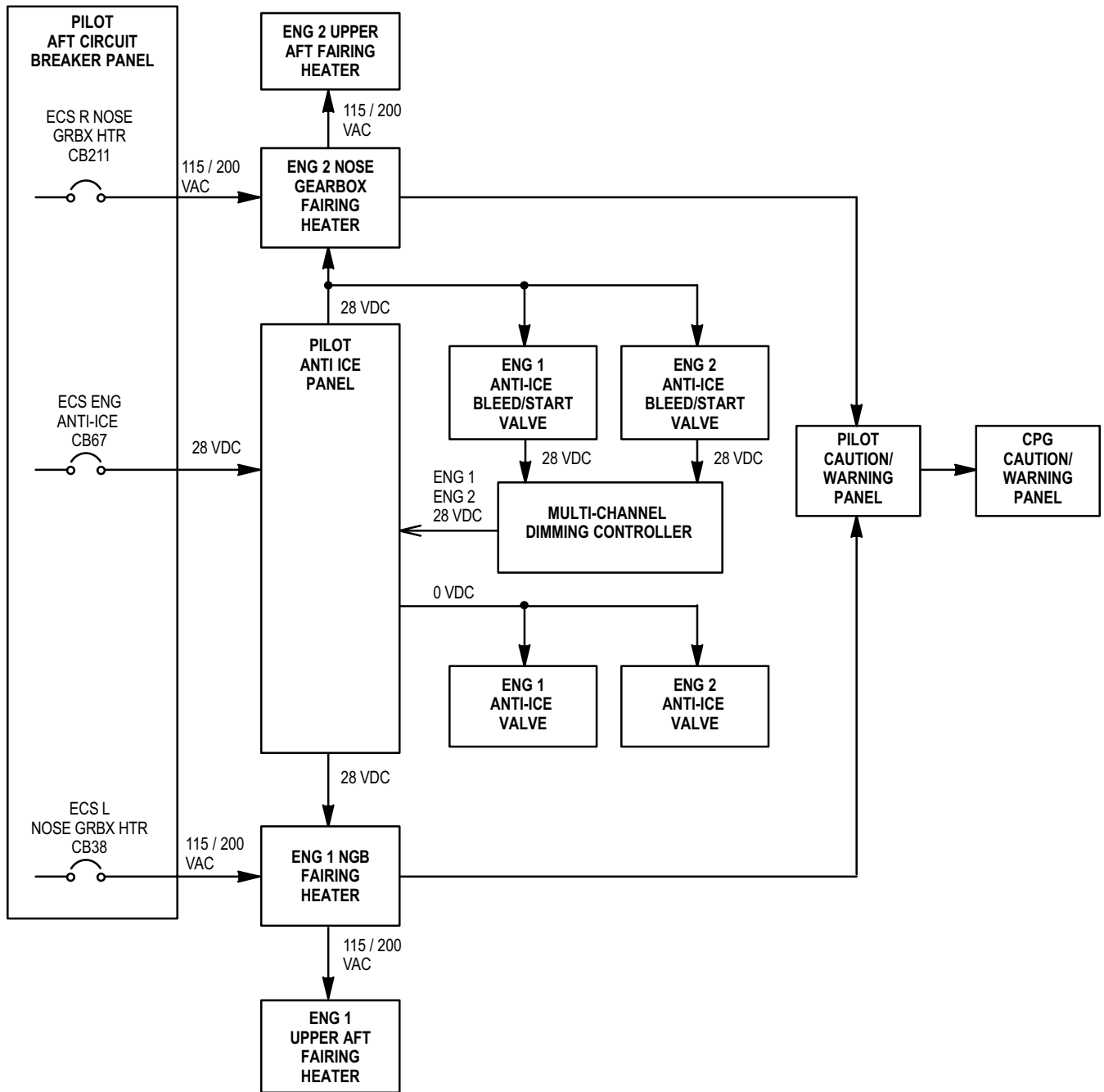

Figure 12-31. Pilot Engine Anti-Ice Off Functional Block Diagram

(c) When the **ENG INLET** anti-ice switch is in the **ON** position, 28 VDC from the **ECS ENG ANTI-ICE** circuit breaker (CB67) is supplied to the engine 1 and engine 2 NGB fairing heater controllers, which are then enabled to supply 115/200 VAC to the appropriate NGB fairing heaters. When the **ENG INLET** anti-ice switch is in the **OFF** position, 28 VDC is removed from the engine NGB fairing heater controllers and the 115/200 VAC to the NGB fairing heaters is also removed.

(d) The engine NGB fairing heaters consist of a heater blanket and controller. When the **ENG INLET** anti-ice switch is in the **ON** position, the engine 1 NGB fairing heater controller enables 115/200 VAC from the **ECS L NOSE GRBX HTR** circuit breaker (CB38) for use with the heater blanket and engine 1 upper aft fairing heater. The engine 2 NGB fairing heater controller enables 115/200 VAC from the **ECS R NOSE GRBX HTR** circuit breaker (CB211) for use with the heater blanket and engine 2 upper aft fairing heater. If the controller senses an open or short, or if an overheat condition exists, the heaters are deactivated and a ground is applied to the pilot and CPG caution/warning panels, lighting the appropriate **ENG ANTI-ICE** indicators.



M71-228

Figure 12-32. Pilot Engine Anti-Ice On Functional Block Diagram

d. Pitot Anti-Ice System.

(1) **Purpose.** The purposes of the Pitot anti-ice system is to prevent ice from forming on the left and right Pitot tubes, enable the OAS anti-ice, enable the ice detector warm air valve and the ice detector sensor.

(2) **System Operation.** The pitot anti-ice system (fig. 12-33) is enabled when the **PITOT ICE DET AD SNSR** switch on the pilot **ANTI ICE** panel is placed to the **ON** position. **PITOT HTR** circuit breaker (CB36) supplies 28 VDC to the left and right Pitot heater and energizes the OAS heater control relay. When the OAS heater control relay is energized, the OAS anti-ice is enabled. **NAV AIR DATA DC** circuit breaker (CB69) supplies 28 VDC to energize the ice detector relay. When the ice detector relay is energized, **ECS ENGINE ANTI-ICE** circuit breaker (CB67) supplies 28 VDC to the ice detector warm air supply valve and **ICE DET HEATER** circuit breaker (CB212) supplies 115 VAC to the ice detector sensor. The ice detector warm air supply valve is used in conjunction with engine anti-ice. The ice detector sensor is used in conjunction with rotor blades de-ice.

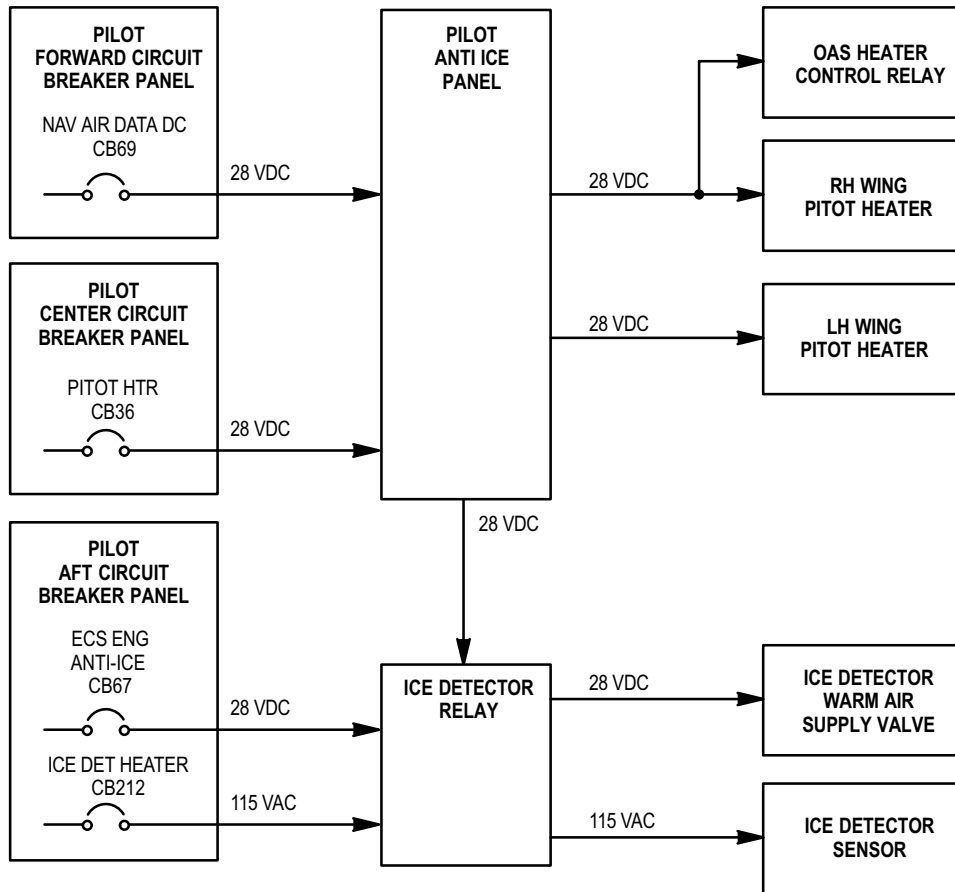

M71-229

Figure 12-33. Pitot Anti-Ice System Functional Block Diagram

e. Rotor Blades De-Ice System.

(1) **Purpose.** The purpose of the rotor blades de-ice system is to provide controlled ice removal from the main and tail rotor blades.

---

**12-7. SYSTEM DESCRIPTION (cont)**

---

12-7

(2) **System Operation.** The rotor blade de-ice system (fig. 12-34) is enabled when the **BLADE** and the **PITOT ICE DET AD SNSR** switches on the pilot **ANTI ICE** panel are placed to the **ON** position. **NAV AIR DATA DC** circuit breaker (CB69) supplies 28 VDC to energize the ice detector relay. When the ice detector relay is energized, **ICE DET HEATER** circuit breaker (CB212) supplies 115 VAC to the ice detector sensor heater and **ECS ENGINE ANTI-ICE** circuit breaker (CB67) supplies 28 VDC to the ice detector warm air supply valve. The ice detector sensor heater prevents icing of the ice detector sensor housing. The ice detector warm air valve is energized open and allows pressurized air to flow through the ice detector sensor housing.

(a) The **ECS BLADE DE-ICE CONTR** circuit breaker (CB83) supplies 28 VDC to the **BLADE ON/OFF/TEST** switch and the rotor blade de-ice controller. The 28 VDC is supplied to energize the blade de-ice relay. The blade de-ice relay supplies a ground to the blade de-ice RCCB. **ECS BLADE DE-ICE** circuit breaker (CB85) supplies 28 VDC enabling the blade de-ice RCCB. When the blade de-ice RCCB is enabled, 115/200 VAC from the generator contactors is applied to the rotor blades de-ice controller. If the input load current exceeds 60 amps for more than 2 seconds the blade de-ice RCCB disconnects the 115/200 VAC from the rotor blades de-ice controller.

(b) The rotor blade de-ice controller rectifies the 115/200 VAC input to  $\pm 134$  VDC heater voltage for the main and tail rotor blades. The heater voltage is transferred to the main and tail rotor blade heater blankets via the main and tail rotor slip ring assemblies. Main and tail rotor heater voltage application is synchronized by the rotor blade de-ice controller to prevent both systems from operating at the same time and creating an overcurrent condition. Heater on time (0 to 22 seconds) is controlled by inputs from the OAT and resistance of the blade heating elements. Heater off time is determined by the **BLADE AUTO/TRACE/LT/MOD** switch. **TRACE** off time is 480 seconds with an output of 1.1 VDC. **LT** off time is 240 seconds with an output of 2.2 VDC. **MOD** off time is 120 seconds with an output of 4.4 VDC. The rotor blade de-ice controller provides outputs to the digital automatic stabilization equipment computer (DASEC) of system status, lights the **BLADE** indicator when de-ice is on, and lights the **BLADE ANTI ICE** indicator on the pilot caution/warning panel in event of failure. In the **AUTO** position, the controller input is 0 to 10.0 VDC determined by the ice detector signal processor. The system will not energize at 0 volts and at 10 volts the off time is less than 60 seconds. The ice detector sensor is supplied 5 volts from the ice detector signal processor, causing the ice detector sensor to vibrate at a specific frequency. PAS air flowing through the ice detector sensor housing draws outside air into the housing. As ice forms on the ice detector sensor, the frequency of the sensor decreases due to the weight of the ice. The frequency is compared to a reference frequency by the ice detector signal processor. If 0.005 to 0.015 inch of ice forms, the ice detector signal processor initiates the blade de-ice sequence which provides 28 VDC to de-ice the ice detector sensor and lights the **ENG ICE** indicator via the multi-channel dimmer controller on the pilot caution/warning panel. When the ice detector sensor is de-iced, the ice detector signal processor removes de-ice power and the sensor is able to detect ice buildup again.

(c) The ice detector signal processor performs built in test (BIT) when instructed by the FCC via the MRTU type I and provides system status to the FCC via the DASEC. A signal output, corresponding to the degree of icing, is provided to the icing severity meter.

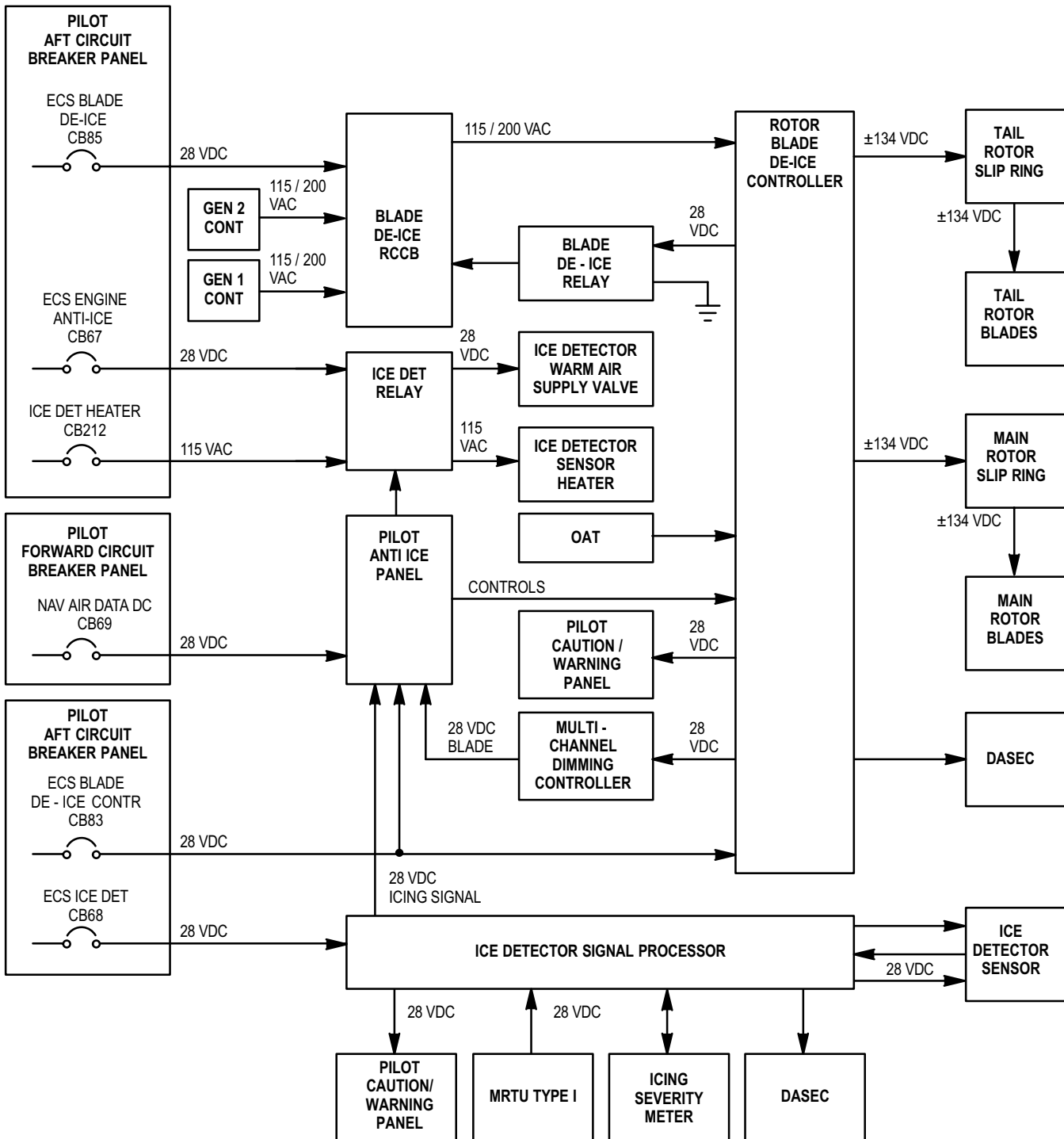

M71-230

Figure 12-34. Rotor Blades De-ice System Functional Block Diagram



f. Windshield Wipers.

(1) **Purpose.** The purpose of the windshield wipers are to remove moisture from the pilot's and CPG's windshields.

(2) **System Operation.** The windshield wiper motors (fig. 12-35) receive 28 VDC power from the **ECS WSHLD WPR** circuit breaker (CB71). The **WSHLD WIPER** switch on the pilot **ANTI ICE** panel operates the wipers at **LOW** speed, **HIGH** speed, and stows the windshield wipers (**PARK**). The **OFF** position removes power from the windshield wipers. The **W WIPER** switch located on the CPG **AUX/ANTI-ICE** panel allows the CPG to select low speed for the CPG windshield regardless of the pilot selection. The windshield wiper motors convert electrical energy to mechanical energy, driving the flexdrives. The flexdrives transmit the rotary output of each motor to the converters. The converters convert the rotary motion to an oscillating motion and reduce the wiper motor input speed.

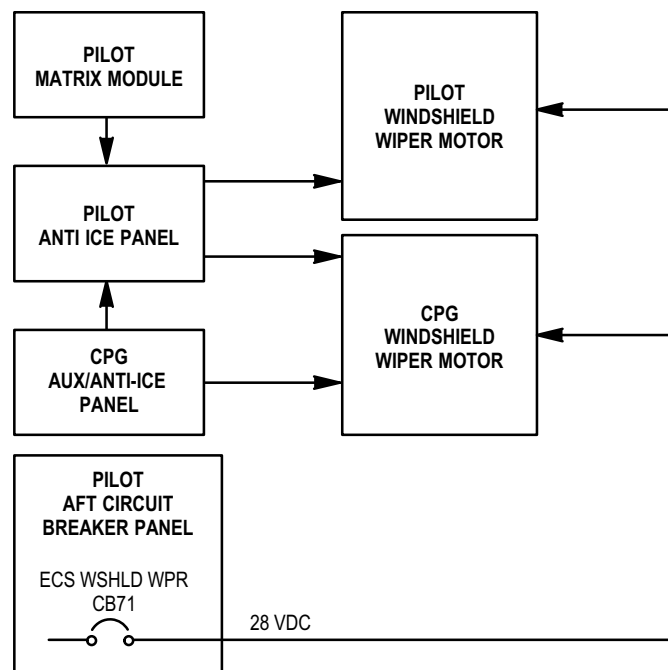

M71-231

Figure 12-35. Windshield Wipers Functional Block Diagram

**g. Engine 1 Fire Detection System.**

(1) **Purpose.** The purpose of the engine 1 fire detection system is to detect fire in the engine 1 compartment.

(2) **System Operation** (fig 12-36). **FIRE DETR ENG 1** circuit breaker (CB12) supplies 28 VDC to engine 1 upper flame detector, engine 1 lower flame detector, engine 1 flame detector amplifier, pilot **APU** fire test panel **FIRE TEST DET** switch and the multi-channel dimming controller. If engine 1 upper or lower flame detectors sense a flame, a signal is generated and sent to engine flame detector amplifier which amplifies the input signal and provides a ground alarm signal to the multi-channel dimming controller. The multi-channel dimming controller provides 28 VDC to light the pilot and CPG **ENG 1 FIRE PULL** handles. The pilot and CPG master caution/warning panels **PRESS TO TEST** is routed through the multi-channel dimming controller to test the **FIRE PULL** handle indicators. When the **FIRE TEST DET** switch is in position **1** it tests engine 1 upper flame detector, position **2** tests engine 1 lower flame detector. If the system is operating properly, all fire pull handles in both crew stations light.

(a) **FIRE EXTGH PLT** circuit breaker (CB25) and **FIRE EXTGH CPG** (CB15) provide 28 VDC to the respective **FIRE BTL** select switches. **FIRE EXTGH CPG** circuit breaker also energizes the light control relays. **FUEL VLV ACTR** circuit breaker (CB14) and **ENG LVR** circuit breaker (CB16) supply 28 VDC to the respective **ENG 1 FIRE PULL** handles.

(b) When the **ENG 1 FIRE PULL** handle is pulled 28 VDC from **ENG LVR** circuit breaker is routed to the engine 1 louver actuator shutoff valve and the environmental control unit (ENCU) relay. The louver actuator shutoff valve energizes, restricting engine compartment airflow. The ENCU relay de-energizes, closing the ENCU shutoff valve. The closed ENCU shutoff valve ensures maximum PAS air for the engine louver system. 28 VDC from **FUEL VLV ACTR** circuit breaker is routed to the pilot **FUEL** panel, actuating the left fuel shutoff valve. Actuation of the left fuel shutoff valve shuts off fuel flow to engine 1.

(c) 28 VDC from the **FIRE BTL** select switch is routed to the selected (**PRI DISCH** or **RES DISCH** switch) fire bottle 1 squib. When the **PRI FIRE BTL** or **RES FIRE BTL** switch is selected, the appropriate squib fires, discharging the contents of the fire bottle into the engine 1 compartment and de-energizes the respective light control relay. When the respective light control relay is de-energized, 28 VDC is routed through the multi-channel dimming controller to light the respective **BTL DISCH** indicator.

12-7. SYSTEM DESCRIPTION (cont)

12-7

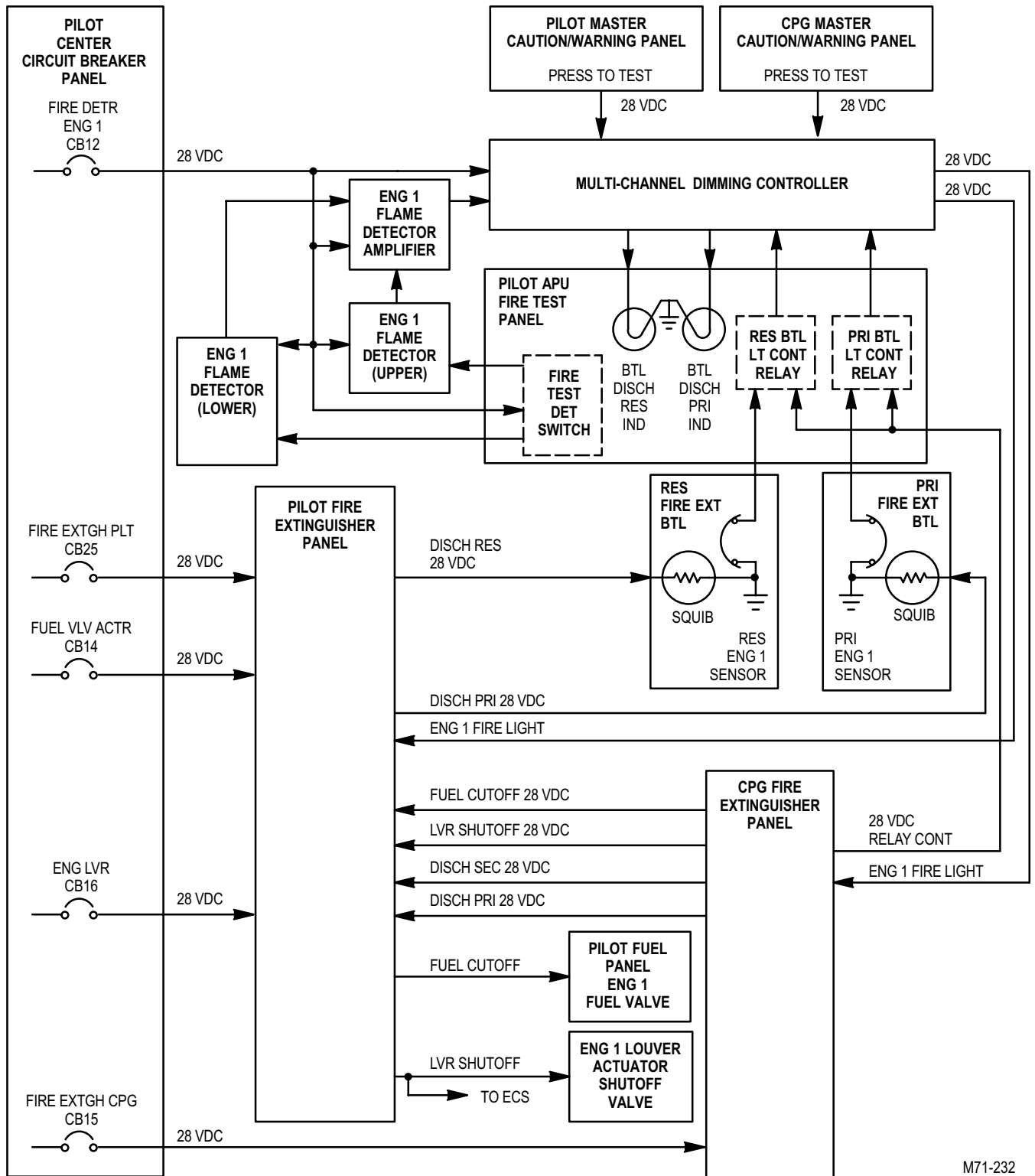

M71-232

Figure 12-36. Engine 1 Fire Detection Functional Block Diagram

#### h. Engine 2 Fire Detection System.

(1) **Purpose.** The purpose of the engine 2 fire detection system is to detect fire in the engine 2 compartment.

(2) **System Operation** (fig 12-37). **FIRE DETR ENG 2** circuit breaker (CB13) supplies 28 VDC to engine 2 upper flame detector, engine 2 lower flame detector, engine 2 flame detector amplifier, and the multi-channel dimming controller. **FIRE DETR ENG 1** circuit breaker (CB12) supplies 28 VDC to pilot **APU** fire test panel **FIRE TEST DET** switch. If engine 2 upper or lower flame detectors sense a flame, a signal is generated and sent to engine 2 flame detector amplifier which amplifier amplifies the input signal and provides a ground alarm signal to the multi-channel dimming controller. The multi-channel dimming controller provides 28 VDC to light the pilot and CPG **ENG 2 FIRE PULL** handles. The pilot and CPG master caution/warning panels **PRESS TO TEST** is routed through the multi-channel dimming controller to test the **FIRE PULL** handle indicators. When the **FIRE TEST DET** switch is in position **1** it tests engine 1 upper flame detector, position **2** tests engine 2 lower flame detector. If the system is operating properly, all fire pull handles in both crew stations light.

(a) **FIRE EXTGH PLT** circuit breaker (CB25) and **FIRE EXTGH CPG** (CB15) provide 28 VDC to the respective **FIRE BTL** select switches. **FIRE EXTGH CPG** circuit breaker also energizes the light control relays. **FUEL VLV ACTR** circuit breaker (CB14) and **ENG LVR** circuit breaker (CB16) supply 28 VDC to the respective **ENG 2 FIRE PULL** handles.

(b) When the **ENG 2 FIRE PULL** handle is pulled, 28 VDC from **ENG LVR** circuit breaker is routed to the engine 2 louver actuator shutoff valve and the ENCU relay. The louver actuator shutoff valve energizes, restricting engine compartment airflow. The ENCU relay de-energizes, closing the ENCU shutoff valve. The closed ENCU shutoff valve ensures maximum PAS air for the engine louver system. 28 VDC from **FUEL VLV ACTR** circuit breaker is routed to the pilot **FUEL** panel, actuating the right fuel shutoff valve. Actuation of the right fuel shutoff valve shuts off fuel flow to engine 2.

(c) 28 VDC from the **FIRE BTL** select switch is routed to the selected (**PRI DISCH** or **RES DISCH**) fire bottle 2 squib. When the **PRI FIRE BTL** or **RES FIRE BTL** switch is selected, the appropriate squib fires, discharging the contents of the fire bottle into the engine 2 compartment and de-energizes the respective light control relay. When the respective light control relay is de-energized, 28 VDC is routed through the multi-channel dimming controller to light the respective **BTL DISCH** indicator.

12-7. SYSTEM DESCRIPTION (cont)

12-7

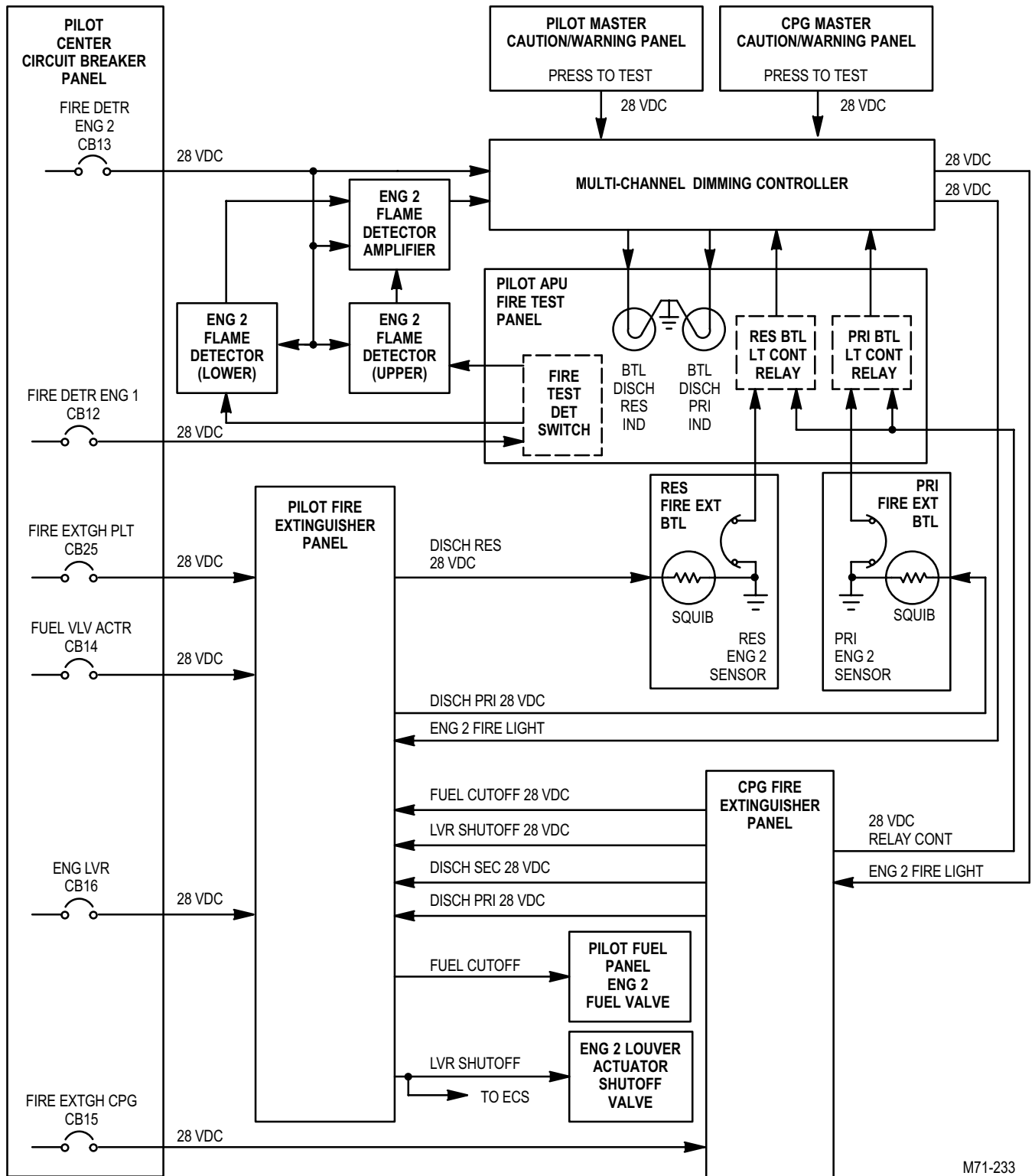

M71-233

Figure 12-37. Engine 2 Fire Detection Functional Block Diagram

i. **APU Fire Detection System.**

(1) **Purpose.** The purpose of the APU fire detection system is to detect fire in the APU and SDC locations in the aft equipment bay.

(2) **System Operation** (fig. 12-38). **FIRE DETR APU** circuit breaker (CB11) supplies 28 VDC to APU upper flame detector, APU lower flame detector, and the APU flame detector amplifier. If APU upper or lower flame detectors, right and left engine firewall louver fire/overheat detectors, or main deck fire/overheat detector senses a flame, a signal is generated and sent to APU fire detector amplifier. The APU fire detector amplifier amplifies the input signal and provides a ground alarm signal to the multi-channel dimming controller. The multi-channel dimming control provides 28 VDC to light the pilot **APU FIRE PULL** handle and the **FIRE APU** segments on the on the master caution/warning panels in both crew stations. The pilot and CPG master caution/warning panels **PRESS TO TEST** are routed through the multi-channel dimming controller to test the **APU FIRE PULL** handle indicator. The CPG caution/warning relay prevents lighting of the **CPG APU FIRE** master caution/warning panel when the pilot master caution/warning **PRESS TO TEST** is initiated.

(a) **FIRE DETR ENG 1** circuit breaker (CB12) supplies 28 VDC to pilot the **APU** fire test panel **FIRE TEST DET** switch. When the **FIRE TEST DET** switch is in position **1** it tests the right engine firewall louver fire/overheat detector, left engine firewall louver fire/overheat detector and APU upper flame detector, position **2** tests main deck fire/overheat detector and APU lower flame detector. If the system is operating properly, the **APU FIRE PULL** handle lights.

(b) **FIRE EXTGH APU** circuit breaker (CB26) provides 28 VDC to the **APU FIRE BTL** select switch. **FIRE EXTGH CPG** circuit breaker (CB15) energizes the reserve and primary light control relays.

(c) When the **APU FIRE PULL** handle is pulled 28 VDC is routed to the APU fuel shutoff valve to shutoff fuel flow to the APU, it also completes a circuit between the selected squib and the **FIRE BTL** select switch. When the **PRI FIRE BTL** or **RES FIRE BTL** switch is selected, 28 VDC is applied to the appropriate fire bottle squib, releasing the fire extinguishing agent. When the fire extinguisher agent is released from the appropriate fire bottle, the fire bottle light control relay is energized. 28 VDC is then routed through the multi-channel dimming controller to light the selected fire extinguisher **BTL DISCH** indicator.

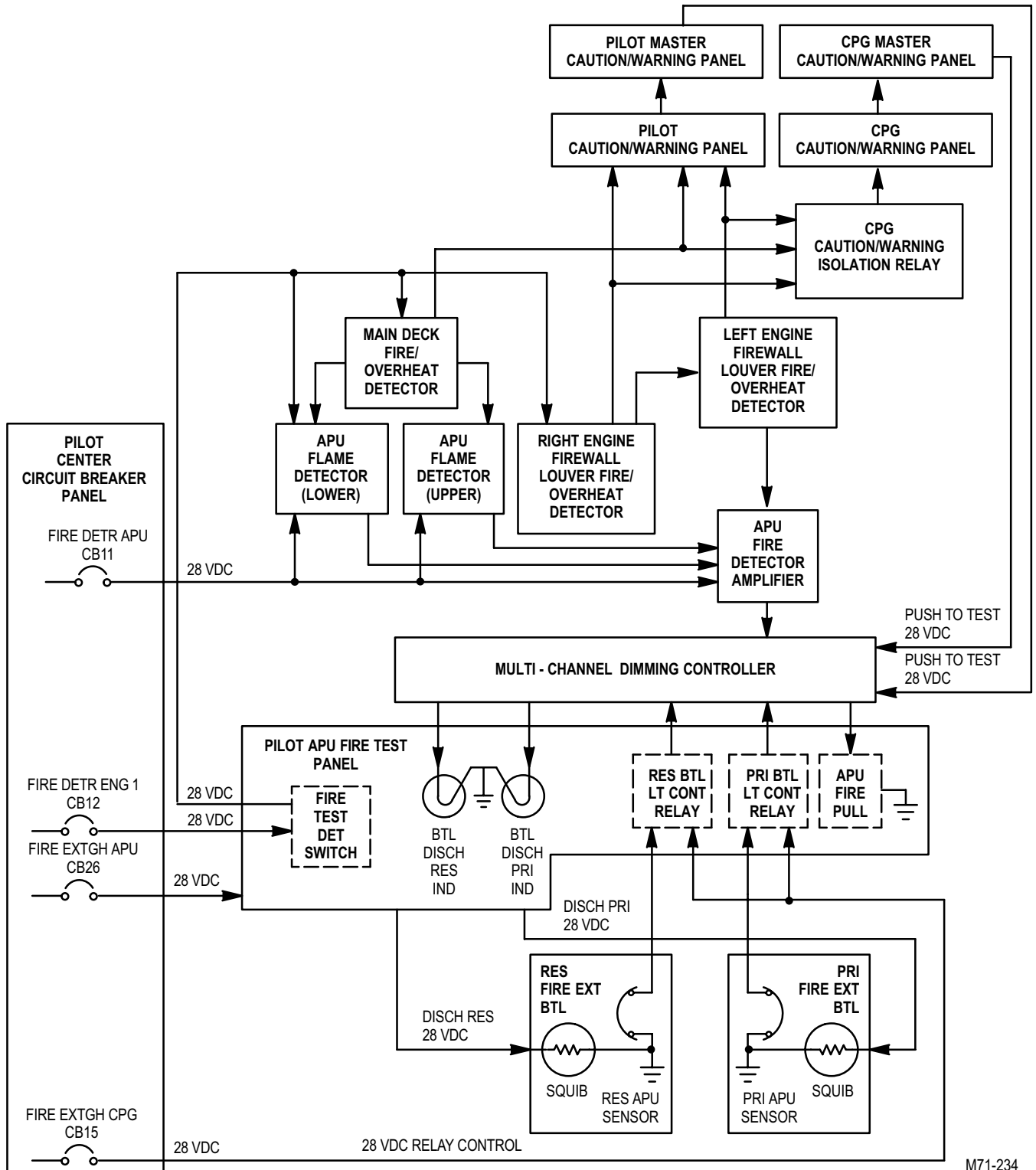

M71-234

Figure 12-38. APU Fire Detection System Functional Block Diagram

**j. Fire Extinguishers.**

(1) **Purpose.** The purposes of the fire extinguishers is to extinguish fire in the engine 1 compartment, engine 2 compartment and APU locations in the aft equipment bay.

(2) **System Operation** (fig. 12-39). **FIRE EXTGH APU** circuit breaker supplies 28 VDC to the **FIRE BTL** switch on the **APU** fire test panel. **FIRE EXTGH PLT** circuit breaker and **FIRE EXTGH CPG** provide 28 VDC to the respective **FIRE BTL** select switches on the fire extinguisher panels. **FIRE EXTGH CPG** circuit breaker also energizes the light control relays. **FUEL VLV ACTR** circuit breaker and **ENG LVR** circuit breaker supply 28 VDC to the **ENG FIRE PULL** handles. When the **ENG FIRE PULL** handle is pulled, 28 VDC from the **ENG LVR** circuit breaker is routed to the appropriate engine louver actuator shutoff valve and the ENCU relay. The louver actuator shutoff valve energizes, restricting engine compartment airflow. The ENCU relay de-energizes, closing the ENCU shutoff valve. The closed ENCU shutoff valve ensures maximum PAS air for the engine louver system. 28 VDC from **FUEL VLV ACTR** circuit breaker is routed to the pilot **FUEL** panel, actuating the right fuel shutoff valve. Actuation of the right fuel shutoff valve shuts off fuel flow to the engine. When the **APU FIRE PULL** handle is pulled 28 VDC is routed to the APU fuel shutoff valve to shutoff fuel flow to the APU, it also completes a circuit between the selected squib and the **FIRE BTL** select switch. When the **PRI FIRE BTL** or **RES FIRE BTL** switch is selected, the appropriate squib fires and 28 VDC is applied to the squib on the appropriate fire bottle, releasing the fire extinguishing agent. When the APU or engine squib fires and the fire extinguisher agent is released from the appropriate fire bottle, the fire bottle light control relay is energized. 28 VDC is then routed through the multi-channel dimming controller to light the selected fire extinguisher **BTL DISCH** indicator.



12-7. SYSTEM DESCRIPTION (cont)

12-7

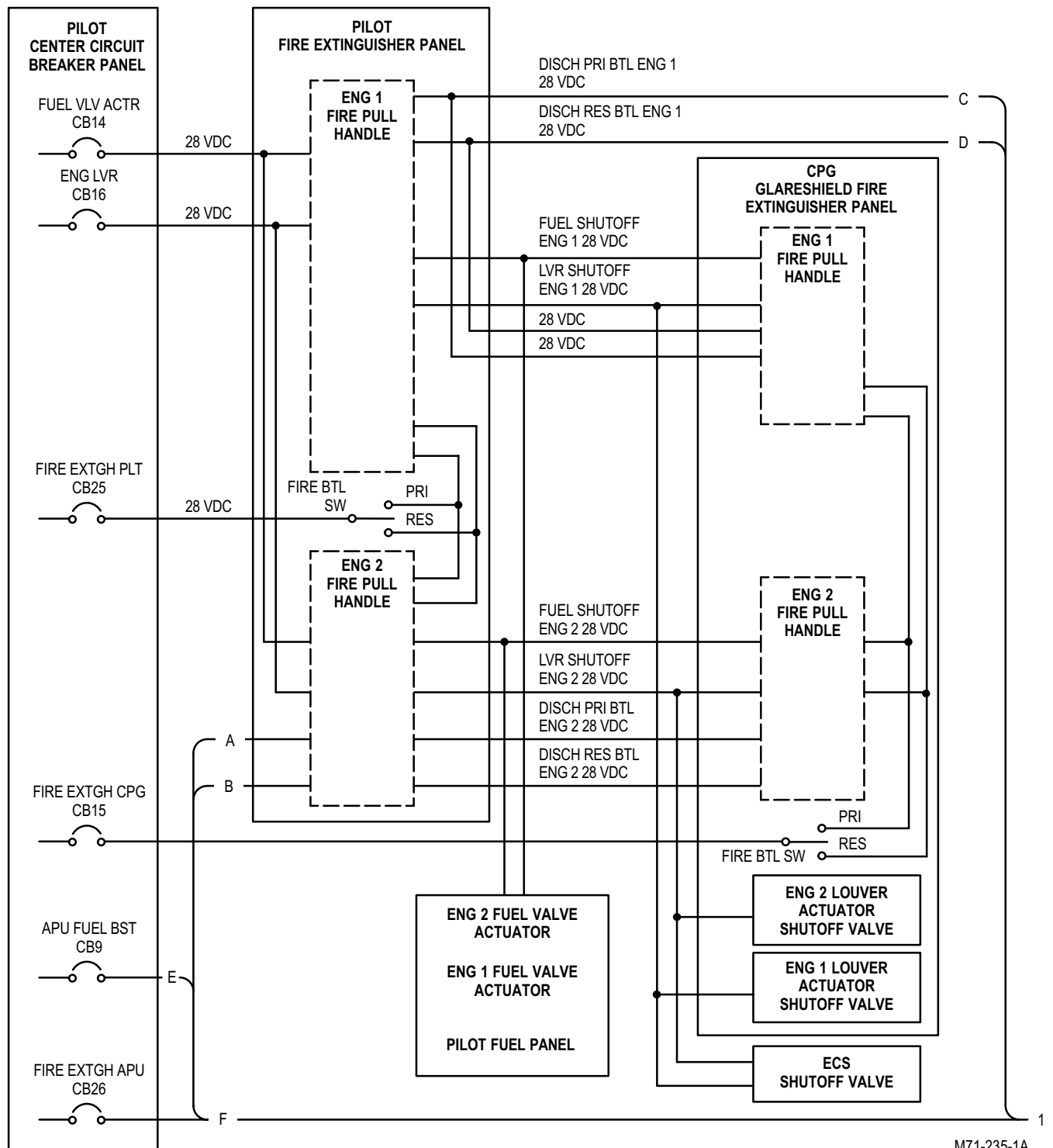

M71-235-1A  
SHEET 1 OF 2

Figure 12-39. Fire Extinguisher Functional Block Diagram (Sheet 1 of 2)

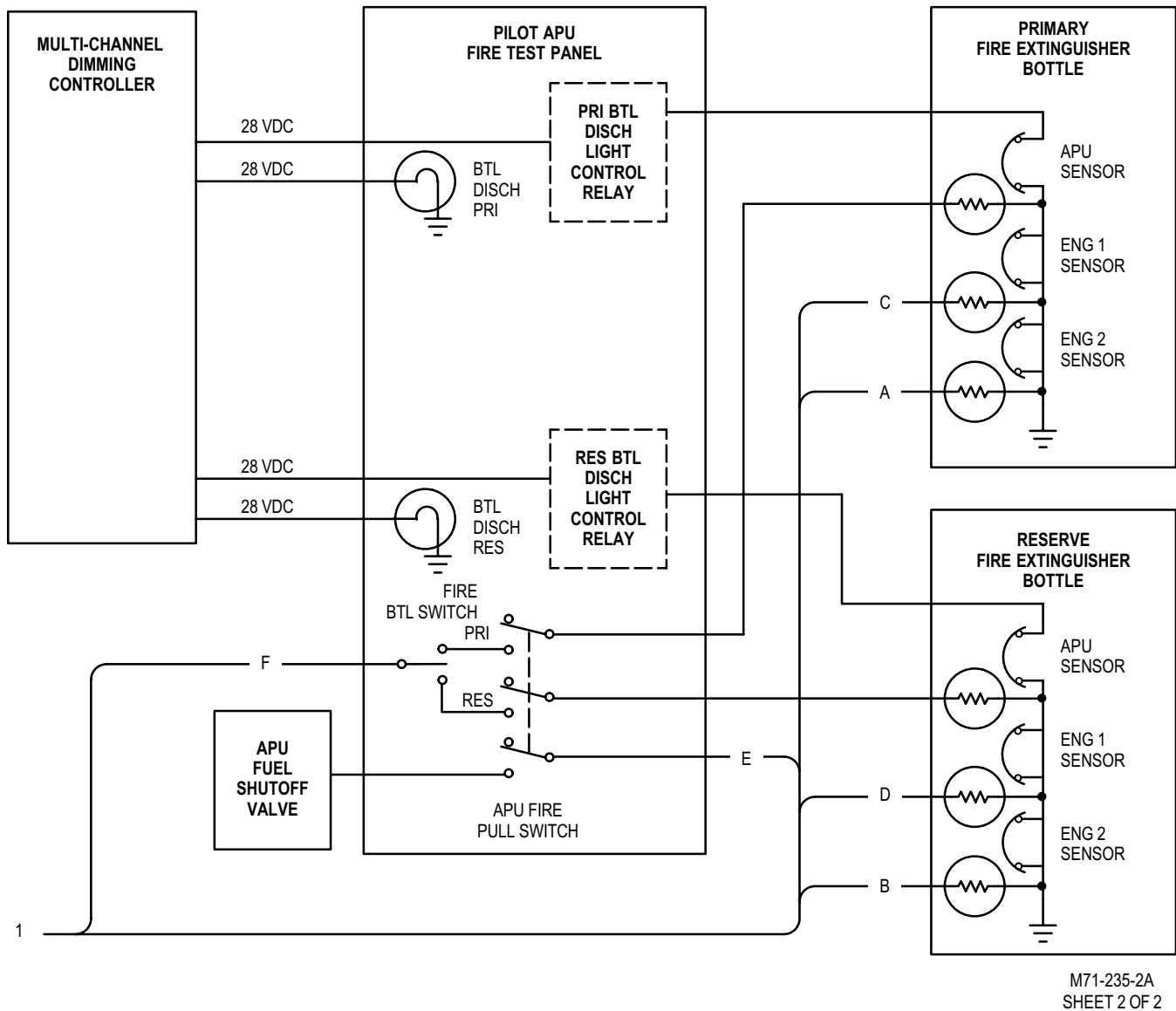

M71-235-2A  
SHEET 2 OF 2

Figure 12-39. Fire Extinguisher Functional Block Diagram (Sheet 2 of 2)

a. The canopy defog and anti-ice system communicates with the FCC. The FCC uses multiplex read codes to issue instructions and to determine system/line replaceable unit (LRU) status. See TM 1-1520-238-T-3 to troubleshoot the canopy defog and anti-ice system.

b. The rotor blades de-ice system communicates with the FCC. The FCC uses multiplex read codes to issue instructions and to determine system/LRU status. See TM 1-1520-238-T-3, to troubleshoot the rotor blades de-ice system.

## SECTION III. TROUBLESHOOTING PROCEDURES

## 12-9. ELECTRICAL COMPONENT LOCATION AND CONFIGURATION (ECLC) INDEX

12-9

Use the information in Table 12-2 to locate the electrical components and their connectors that you have to locate to perform the troubleshooting tasks in this chapter. Table 12-2 includes locator illustrations which supplement the ECLC listing. The entry in the grid area column in the listing tells you where to locate the component in the illustrations.

*Table 12-2. Electrical Component Location and Configuration (ECLC) Index Listing*

FROM COLUMN		TO COLUMN		Grid Area	Access
Connector Ref Des	Component/Harness	Connector Ref Des	Component/Harness		
P1	W605	J1	A402	56A	PLT STATION
P1	SR1	J1	HTR	85D	L200 PANEL
P1	DS28	J164	W118	28C	PLT STATION
P1	DS31	J166	W118	16C	CPG STATION
P1	W221	J757	W119	82E	L200 PANEL
P1	W221	J758	W119	81D	L200 PANEL
P1010	W156	J1	HR5	59C	RIGHT PITOT TUBE
P1034	SR2	J1034	HTR	111C	TAIL ROTOR
P1035	SR2	J1035	HTR	111D	TAIL ROTOR
P1036	SR2	J1036	HTR	110D	TAIL ROTOR
P1042	W118	J1	A176	95A	R325 DOOR
P1087	W211	J1	A337	81C	L200 PANEL
P115	W155	J115	W119	60E	LW10 FAIRING
P116	W156	J116	W118	57A	RW10 FAIRING
P124	W171	J124	W170	106A	R510 FAIRING
P1320	W118	J1	A698	97D	R200 PANEL
P1321	W119	J1	A697	84B	L200 PANEL
P1322	W119	J1	A699	97D	R200 PANEL
P174	W119	J1	A131	42D	PLT STATION

Table 12-2. Electrical Component Location and Configuration (ECLC) Index Listing (cont)

FROM COLUMN		TO COLUMN		Grid Area	Access
Connector Ref Des	Component/Harness	Connector Ref Des	Component/Harness		
P176	WII8	J1	A138	51B	PLT STATION
P178	W119	J1	A135	41B	PLT STATION
P18	W118	J1	A106	45C	PLT STATION
P19	W118	J1	A157	1B	R40 COVER
P2	SR1	J1	HTR	88E	L200 PANEL
P2	W605	J2	A402	56C	PLT STATION
P2	HR3	J2	HR3	61D	LN6
P2	HR4	J2	HR4	72B	RN6
P20	W118	J2	A106	45A	PLT STATION
P208	W115	J1	HR6	57E	LEFT PITOT TUBE
P21	W165	J21	W119	67D	LN1 ENG 1
P213	W149	J213	W119	67D	L200 PANEL
P214	W164	J214	W118	75E	RN1 ENG 2
P22	W166	J22	A118	74E	RN1 ENG 2
P261	W119	J1	A32	81D	L200 PANEL
P289	W119	J1	B4	8B	L40 COVER
P290	W119	J1	B5	2B	R40 COVER
P291	W119	J2	A48	23B	CPG STATION
P292	W119	J1	A48	23B	CPG STATION
P3	SR1	J1	HTR	88D	L200 PANEL
P31	W118	J2	A157	1D	R40 COVER
P33	W165	J1	L2	66D	LN1 ENG 1
P34	W166	J1	L2	76E	RN1 ENG 2
P4	SR1	J1	HTR	85B	L200 PANEL
P403	W119	J403	W117	6B	L40 COVER

## 12-9. ELECTRICAL COMPONENT LOCATION AND CONFIGURATION (ECLC) INDEX (cont)

12-9

Table 12-2. Electrical Component Location and Configuration (ECLC) Index Listing (cont)

FROM COLUMN		TO COLUMN		Grid Area	Access
Connector Ref Des	Component/Harness	Connector Ref Des	Component/Harness		
P429	W119	J23	A402	55E	PLT STATION
P431	W211	J25	A402	53D	PLT STATION
P433	W119	J20	A402	55E	PLT STATION
P437	W119	J25	A402	53E	PLT STATION
P438	W118	J15	A402	54C	PLT STATION
P439	W119	J21	A402	55E	PLT STATION
P440	W118	J16	A402	54C	PLT STATION
P441	W119	J24	A402	55D	PLT STATION
P442	W102	J5	A402	54B	PLT STATION
P448	W118	J448	W119	37D	PLT STATION
P449	W211	J449	W119	79E	T205L FAIRING
P45	W165	J1	E3	65D	LN1 ENG 1
P450	W118	J19	A402	54A	PLT STATION
P455	W170	J455	W211	101E	R295 DOOR
P456	W118	J456	W211	37C	PLT STATION
P457	W119	J22	A402	55E	PLT STATION
P46	W166	J1	E3	73C	RN1 ENG 2
P463	W119	J1	A76	40D	PLT STATION
P465	W119	J2	A326	35C	CPG STATION
P466	W118	J14	A326	33C	CPG STATION
P47	HR3	J47	W119	84C	L325 DOOR
P475	W119	J475	A327	32B	PLT STATION
P473	W119	J6	A326	35C	CPG STATION
P478	W116	J17	A402	54B	PLT STATION
P48	HR4	J48	W118	93C	R325 DOOR

Table 12-2. Electrical Component Location and Configuration (ECLC) Index Listing (cont)

FROM COLUMN		TO COLUMN		Grid Area	Access
Connector Ref Des	Component/Harness	Connector Ref Des	Component/Harness		
P480	W118	J16	A326	33B	CPG STATION
P487	W119	J9	A326	35C	CPG STATION
P488	W118	J18	A402	54C	PLT STATION
P527	W119	J527	A331	32C	PLT STATION
P62	W119	J1	L11	83E	L200 PANEL
P63	W102	J1	L12	95C	R295 DOOR
P670	W255	J1	A61	1E	R40 COVER
P673	W117	J3	A63	9C	L90 DOOR
P685	W117	J2	A63	10D	L90 DOOR
P688	W211	J1	A69	104C	R295 DOOR
P690	W119	J1	A695	86B	R200 PANEL
P691	W119	J2	A32	81D	L200 PANEL
P747	W119	J1	A403	12D	L90 DOOR
P748	W119	J2	A403	12E	L90 DOOR
P762	W119	J1	A417	19C	CPG STATION
P78	W118	J1	A10	99E	L325 DOOR
P79	W118	J1	A11	100B	L325 DOOR
P791	W118	J1	A311	91B	R295 DOOR
P792	W118	J2	A311	91C	R295 DOOR
P82	W164	J1	A16	76C	RN1ENG2
P83	W164	J1	A15	73E	RN1ENG2
P84	W118	J1	AR2	100D	L325 DOOR
P85	W118	J1	AR1	100C	L325 DOOR
P872	W119	J1	L50	77D	T205L FAIRING
P88	W149	J1	A13	65B	LN1 ENG 1

12-9. ELECTRICAL COMPONENT LOCATION AND CONFIGURATION (ECLC) INDEX (cont)

12-9

*Table 12-2. Electrical Component Location and Configuration (ECLC) Index Listing (cont)*

FROM COLUMN		TO COLUMN		Grid Area	Access
<u>Connector Ref Des</u>	<u>Component/Harness</u>	<u>Connector Ref Des</u>	<u>Component/Harness</u>		
P89	W149	J1	A12	68D	LN1 ENG 1
P90	W119	J1	AR3	82E	L200 PANEL
P908	W118	J908	W119	21C	CPG STATION
P914	W118	J914	W119	21C	CPG STATION
P953	W166	J1	S126	76D	RN1 ENG 2
P954	W165	J1	S127	65C	LN1 ENG 1
P956	W119	J1	L45	83B	L200 PANEL
P999	SR2	J999	HTR	111C	TAIL ROTOR

Table 12-2. Electrical Component Location and Configuration (ECLC) Index Listing (cont)

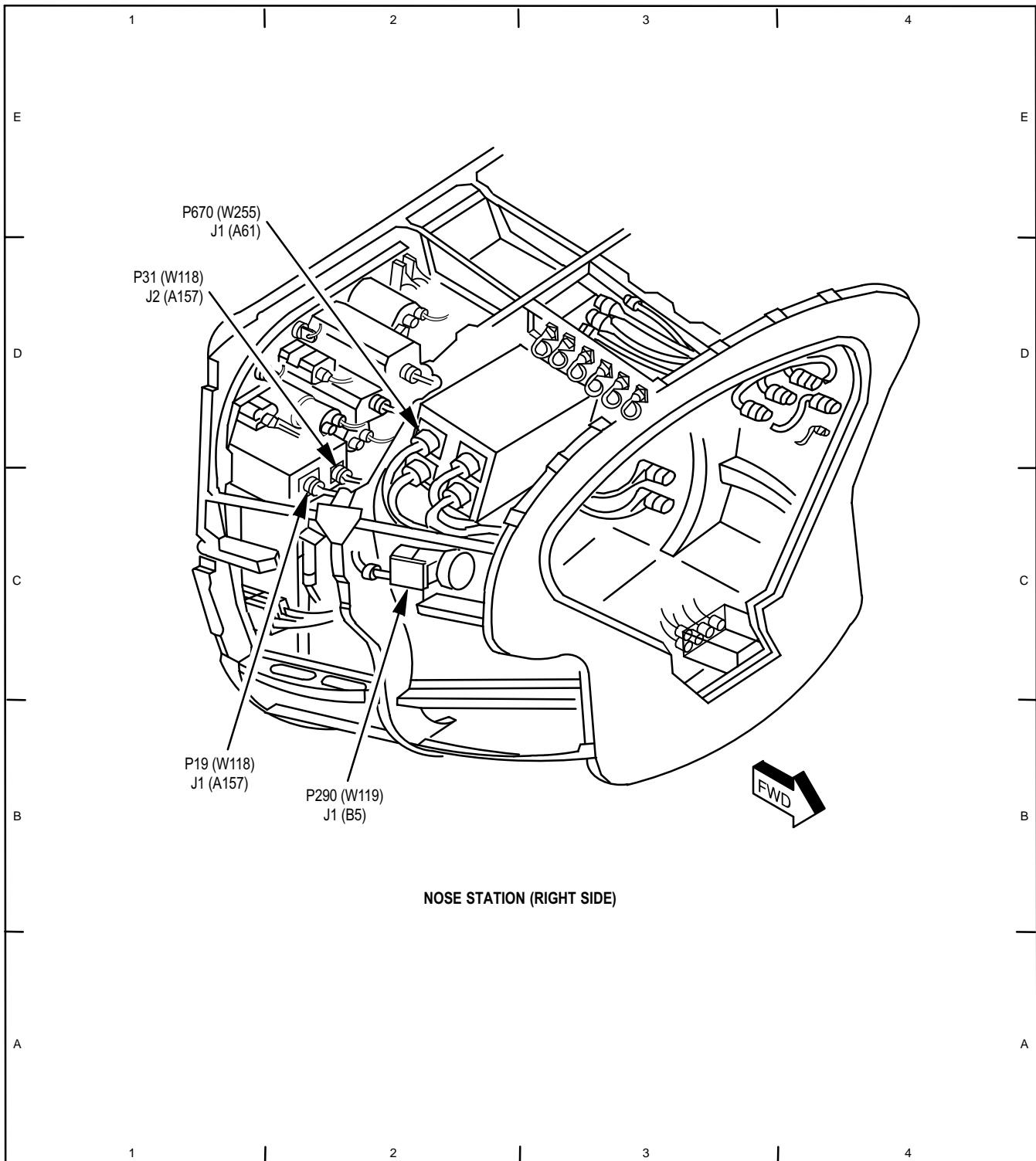

M71-248A



12-9. ELECTRICAL COMPONENT LOCATION AND CONFIGURATION (ECLC) INDEX (cont)

12-9

Table 12-2. Electrical Component Location and Configuration (ECLC) Index Listing (cont)

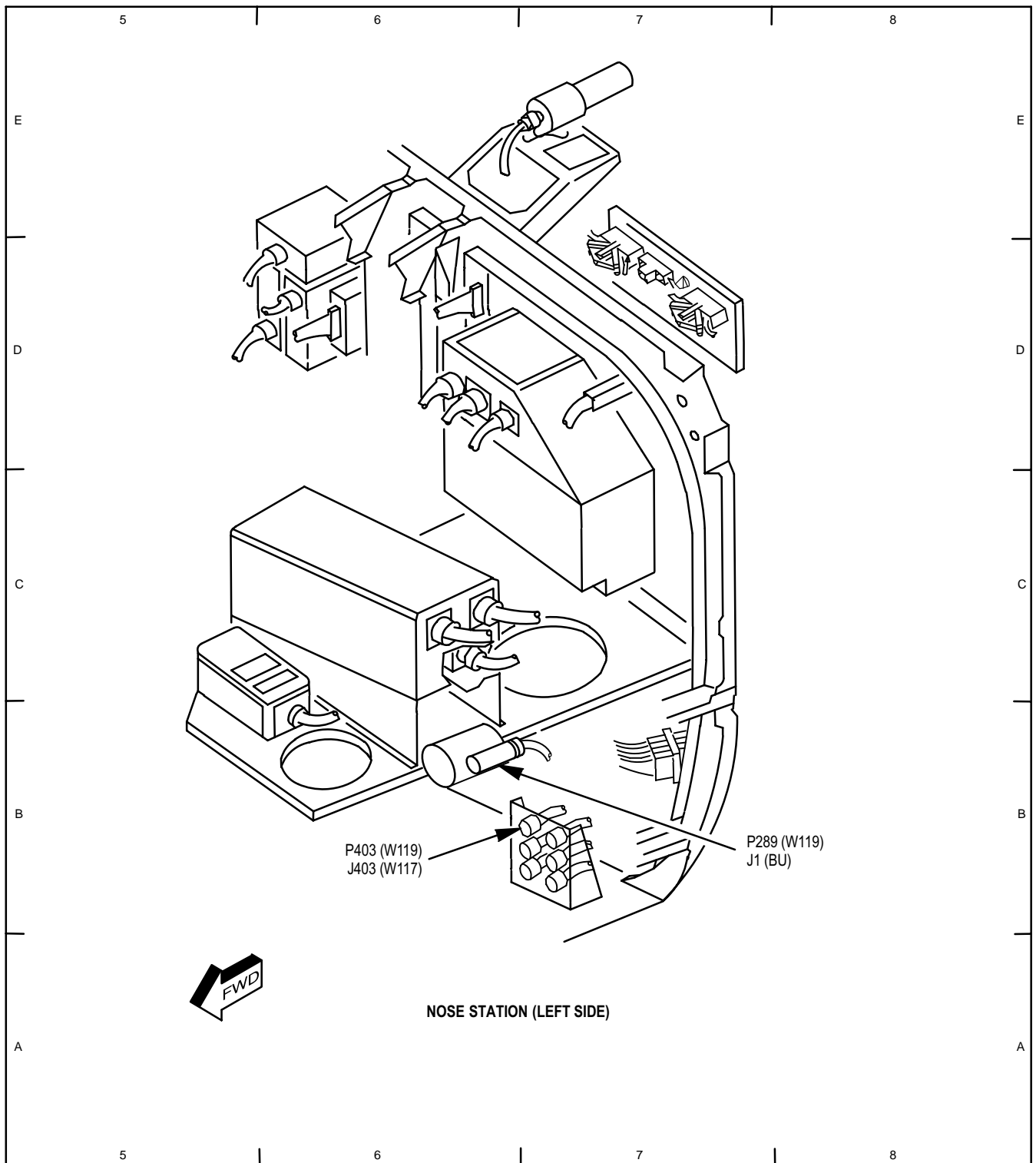

M71-249A

Table 12-2. Electrical Component Location and Configuration (ECLC) Index Listing (cont)

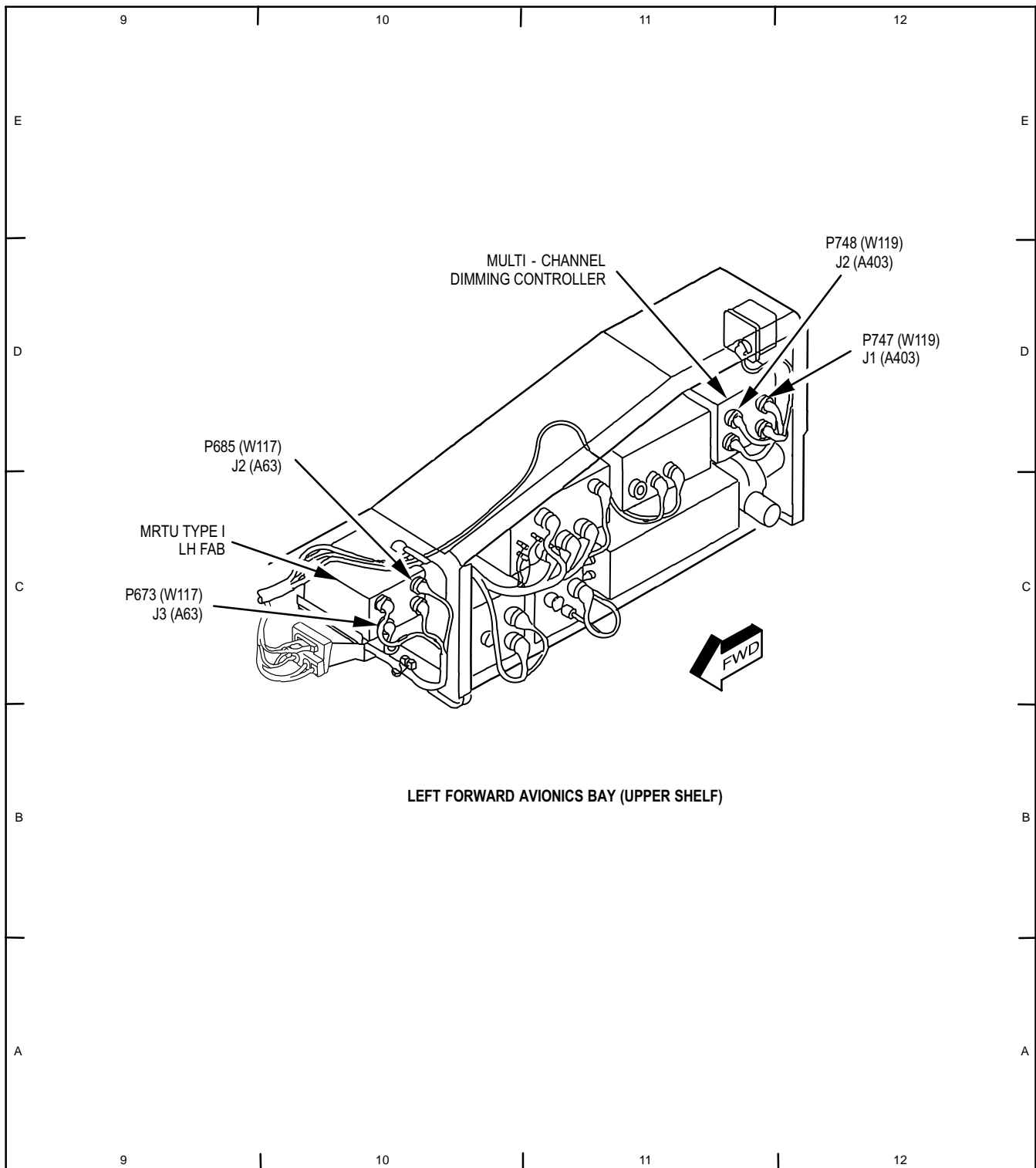

M71-251A

12-9. ELECTRICAL COMPONENT LOCATION AND CONFIGURATION (ECLC) INDEX (cont)

12-9

Table 12-2. Electrical Component Location and Configuration (ECLC) Index Listing (cont)

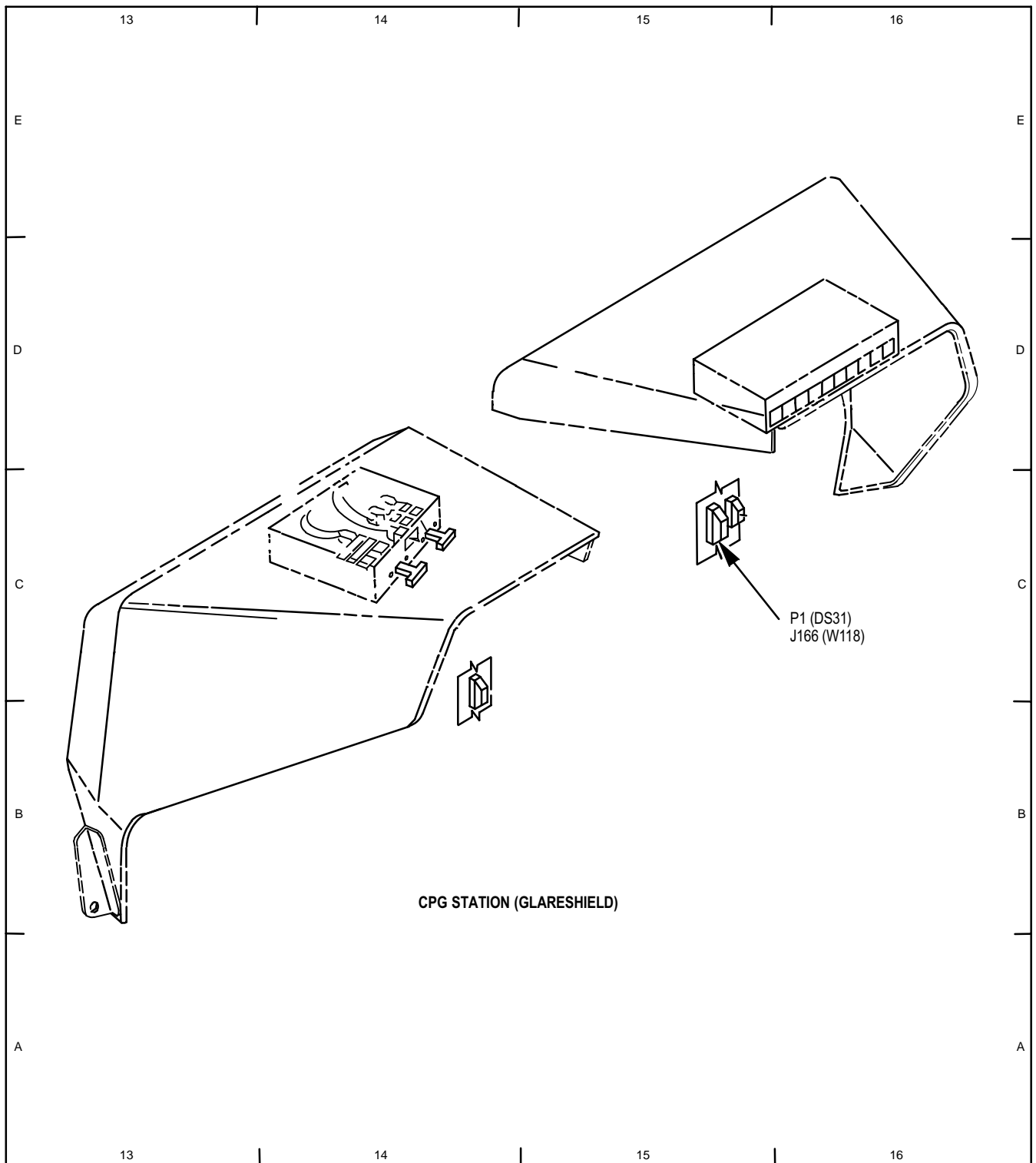

M71-273

Table 12-2. Electrical Component Location and Configuration (ECLC) Index Listing (cont)

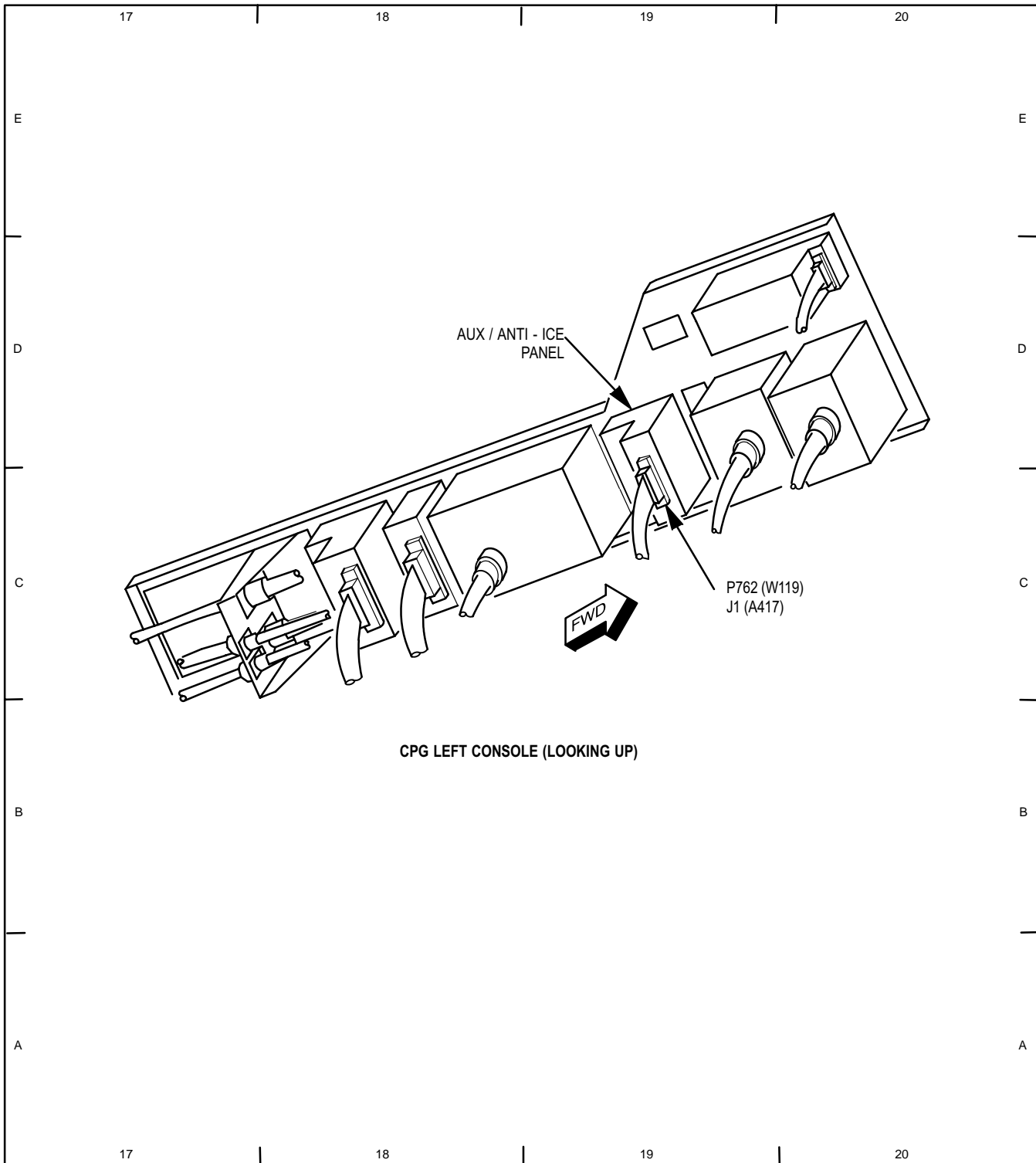

M71-252A

12-9. ELECTRICAL COMPONENT LOCATION AND CONFIGURATION (ECLC) INDEX (cont)

12-9

Table 12-2. Electrical Component Location and Configuration (ECLC) Index Listing (cont)

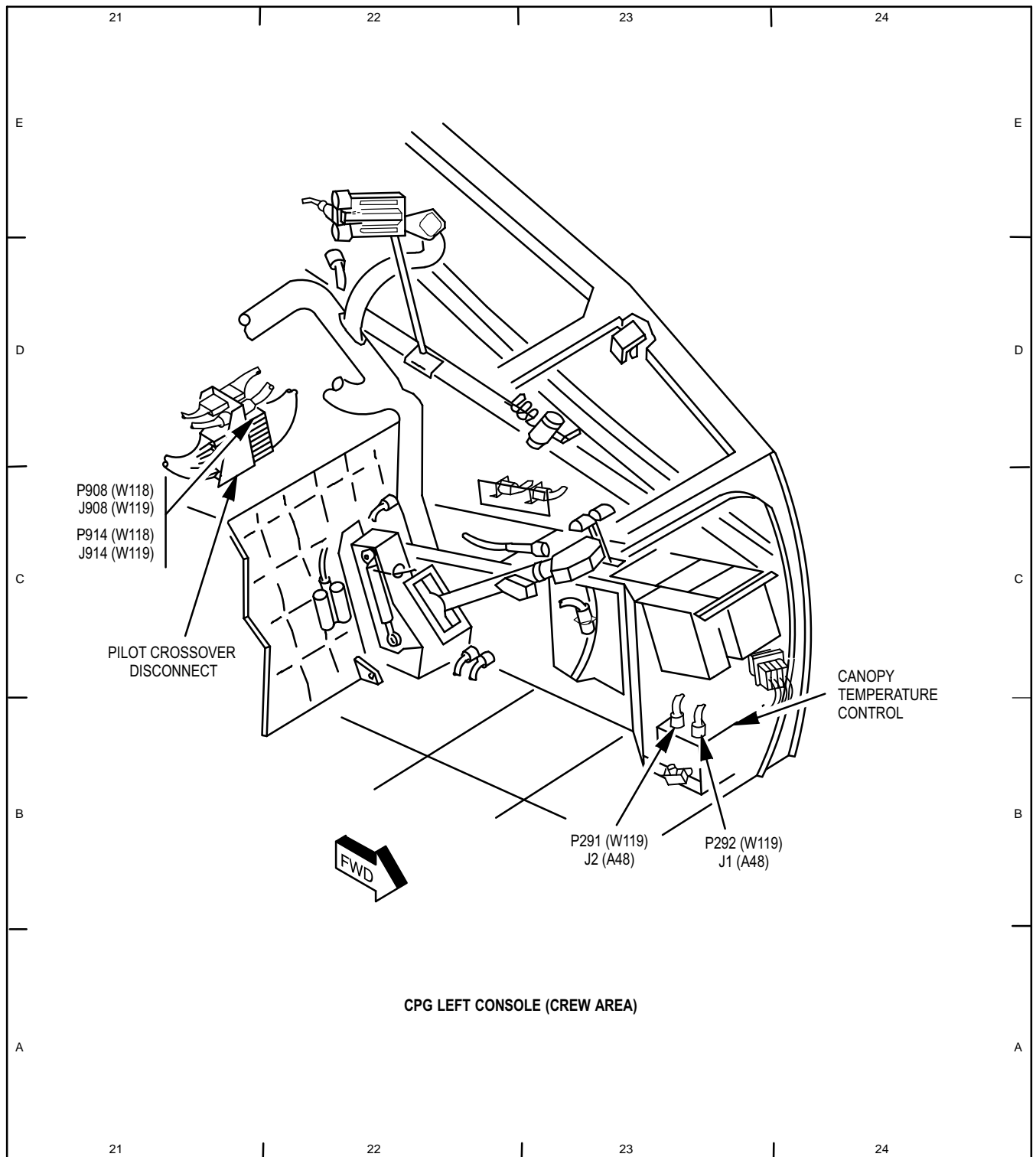

M71-253A

Table 12-2. Electrical Component Location and Configuration (ECLC) Index Listing (cont)

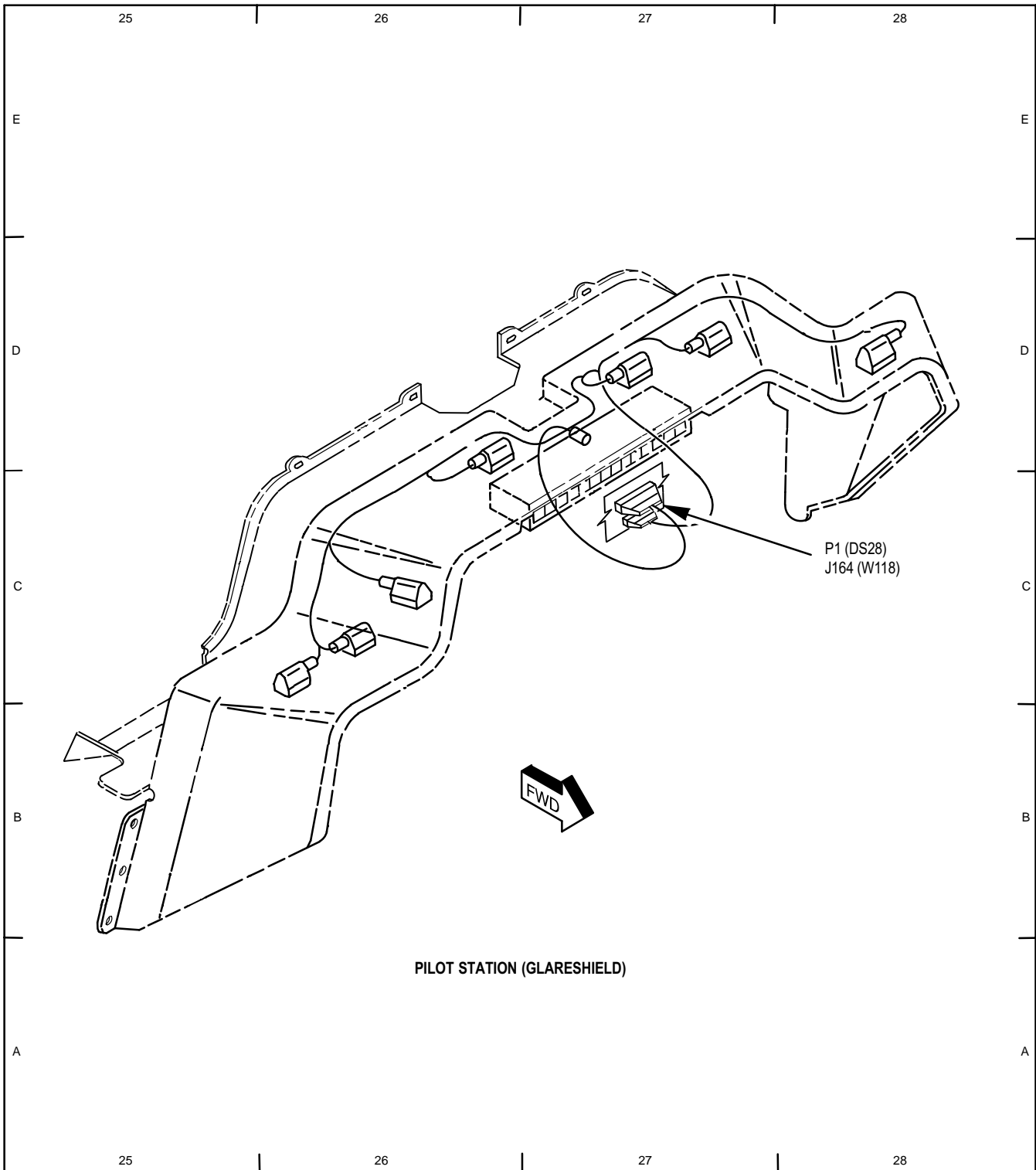

M71-274

12-9. ELECTRICAL COMPONENT LOCATION AND CONFIGURATION (ECLC) INDEX (cont)

12-9

Table 12-2. Electrical Component Location and Configuration (ECLC) Index Listing (cont)

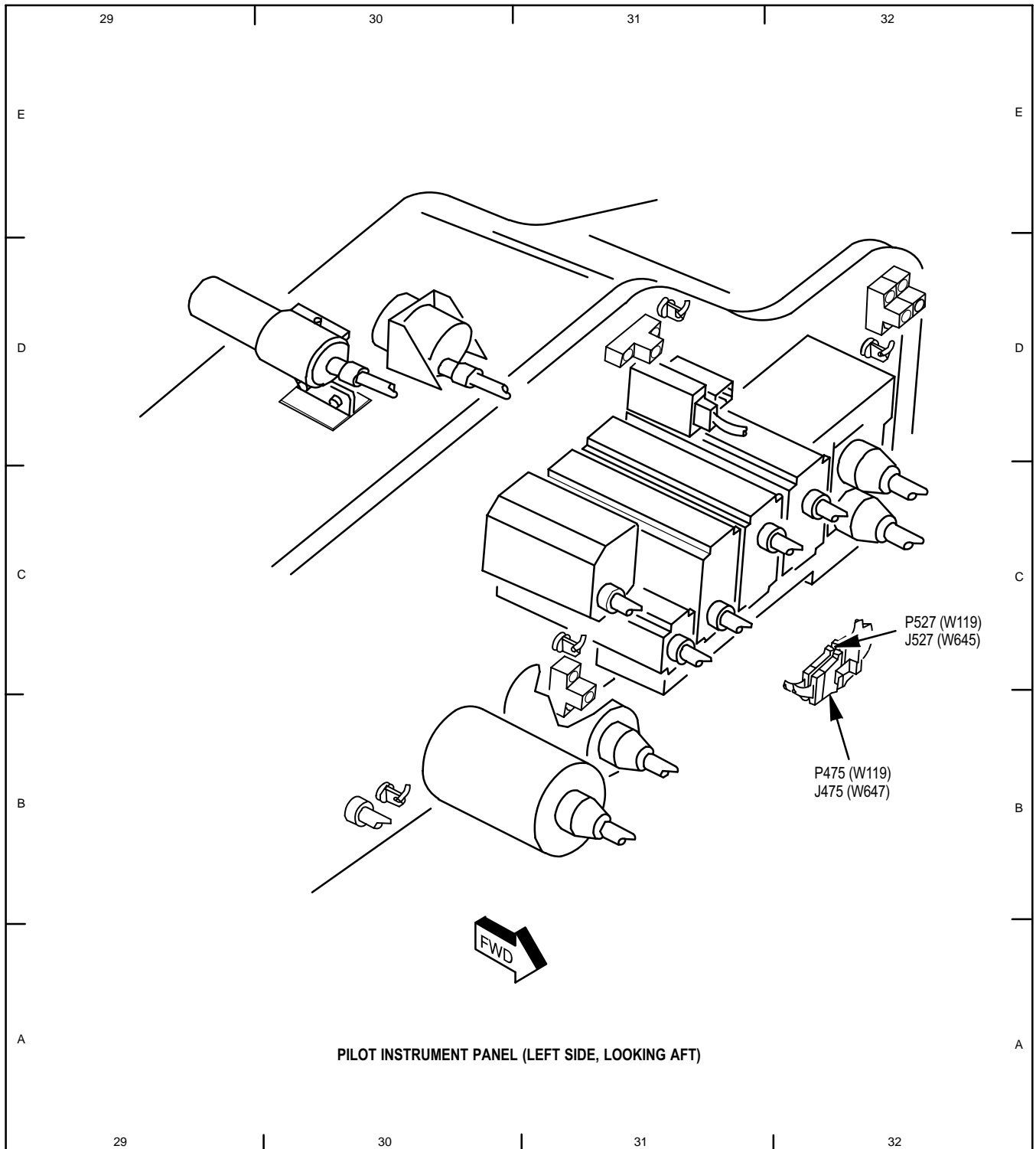

M71-275

Table 12-2. Electrical Component Location and Configuration (ECLC) Index Listing (cont)

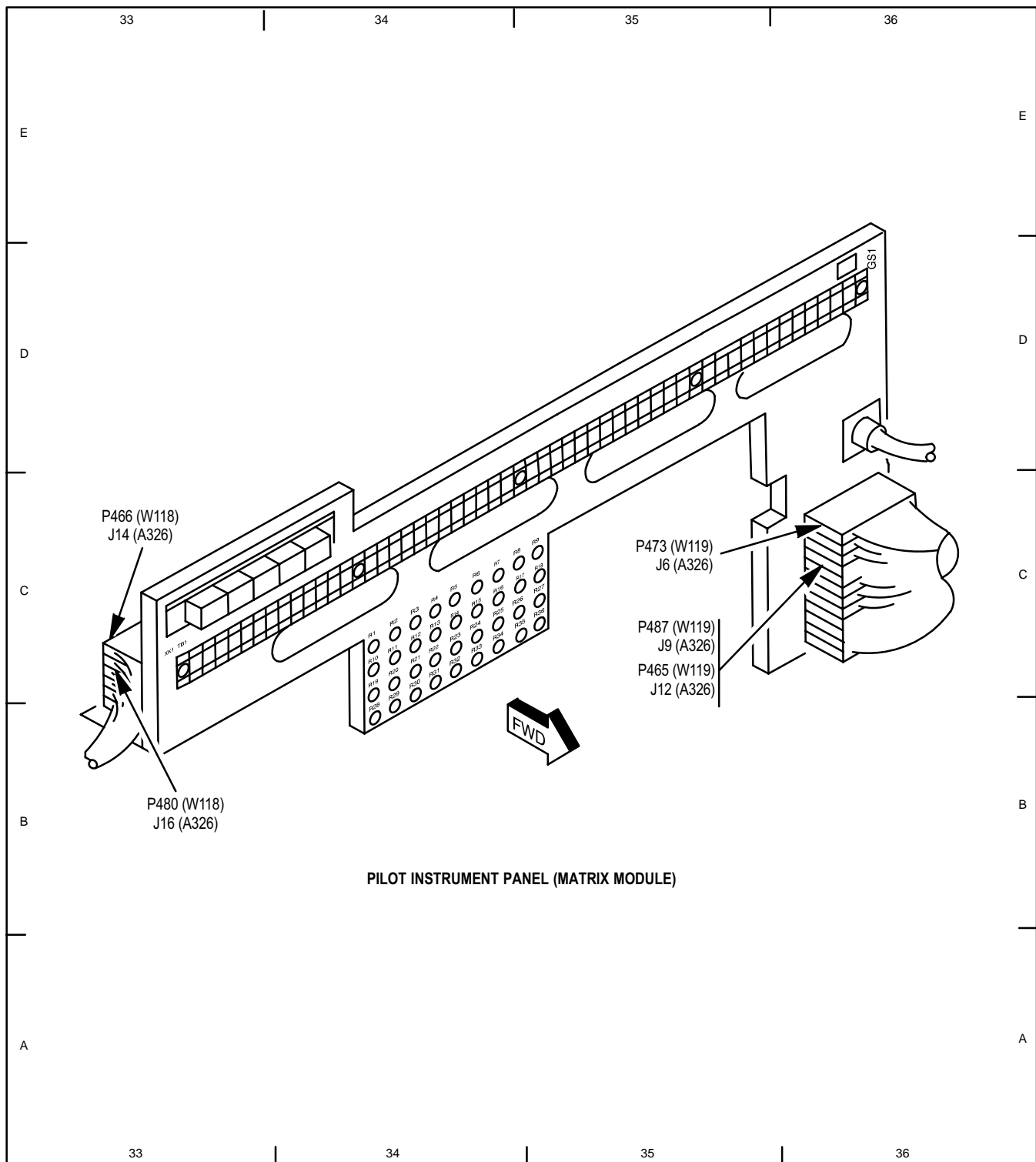

M71-259A



12-9. ELECTRICAL COMPONENT LOCATION AND CONFIGURATION (ECLC) INDEX (cont)

12-9

Table 12-2. Electrical Component Location and Configuration (ECLC) Index Listing (cont)

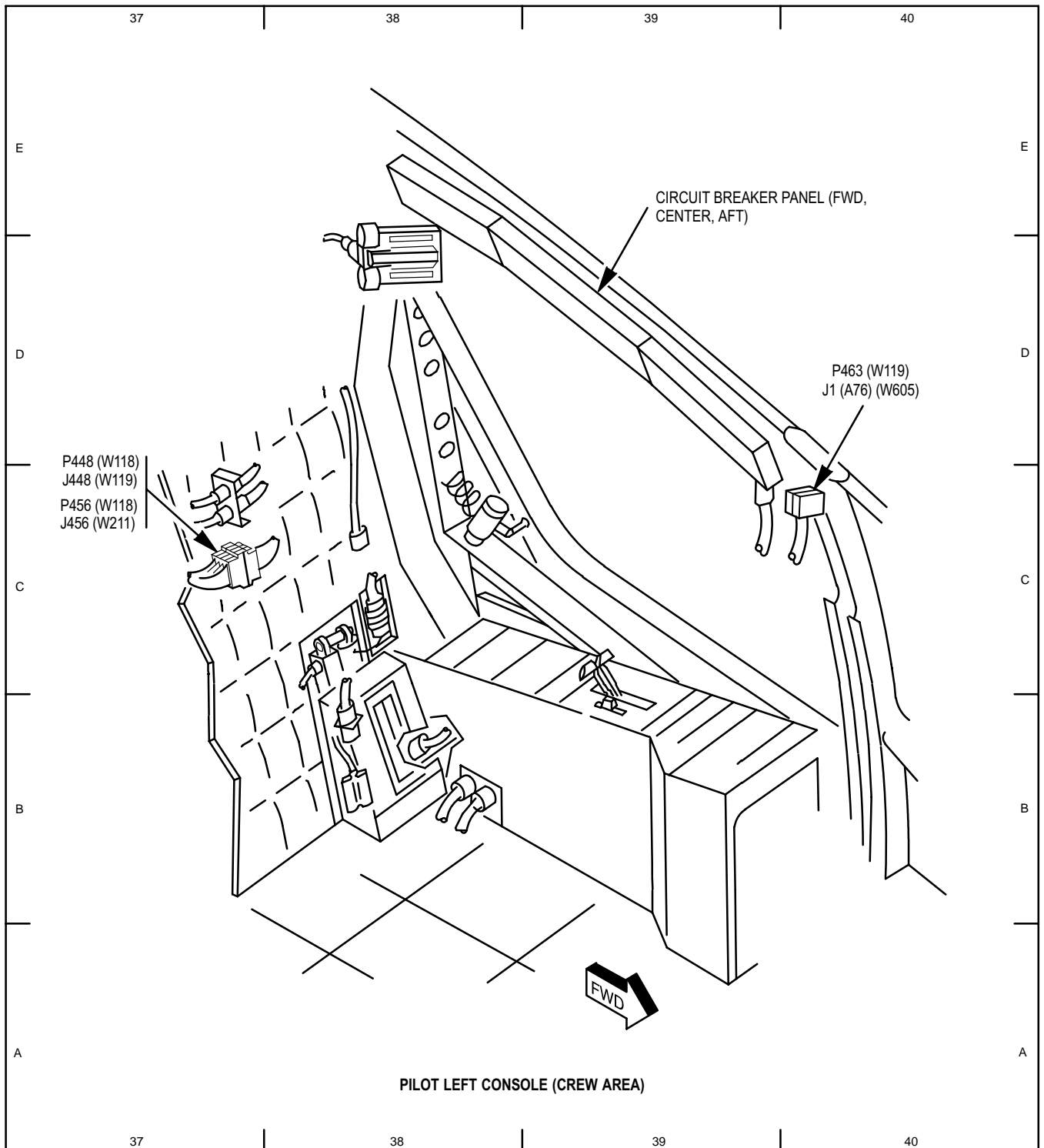

M71-256A

Table 12-2. Electrical Component Location and Configuration (ECLC) Index Listing (cont)

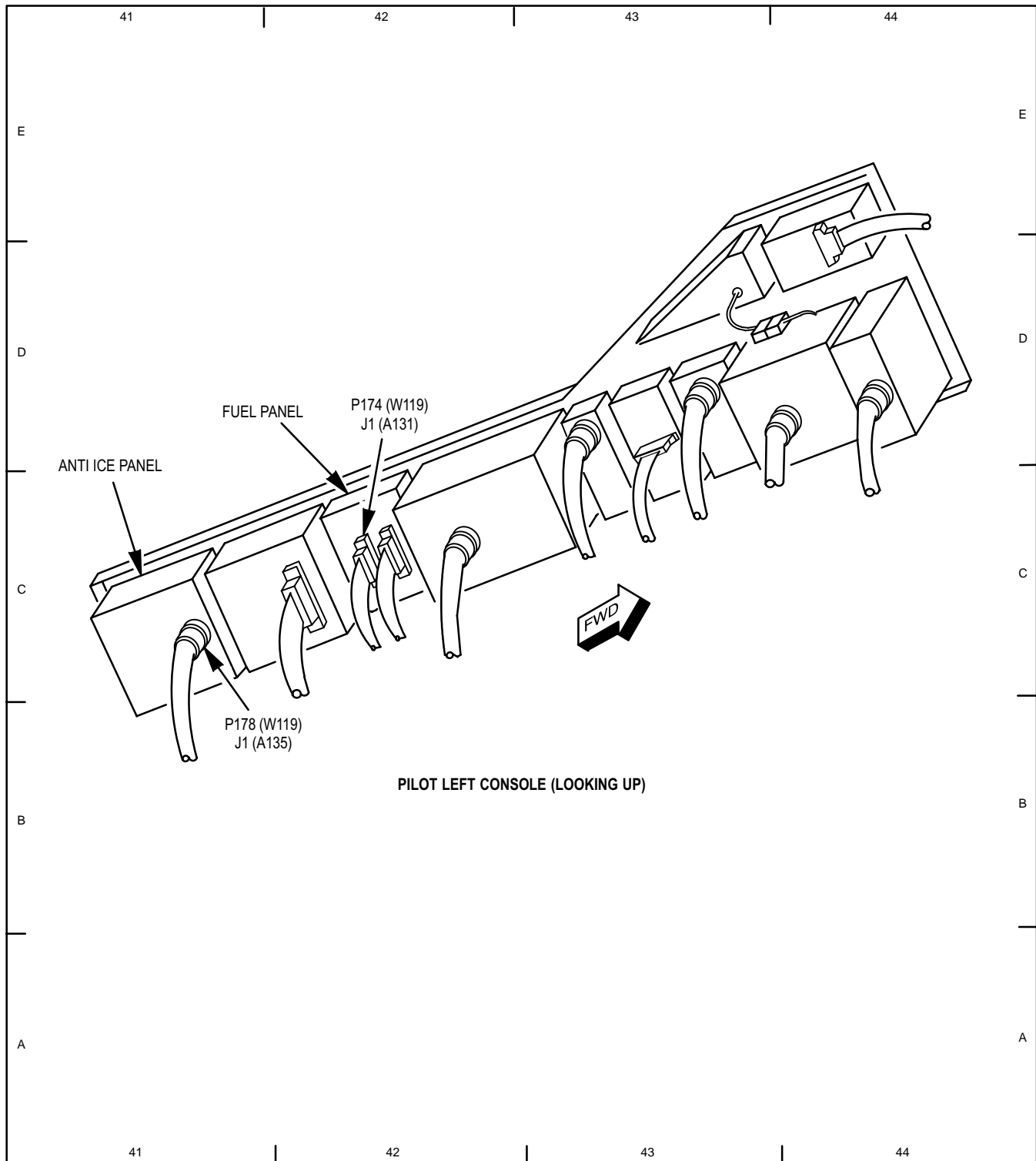

M71-257A

12-9. ELECTRICAL COMPONENT LOCATION AND CONFIGURATION (ECLC) INDEX (cont)

12-9

Table 12-2. Electrical Component Location and Configuration (ECLC) Index Listing (cont)

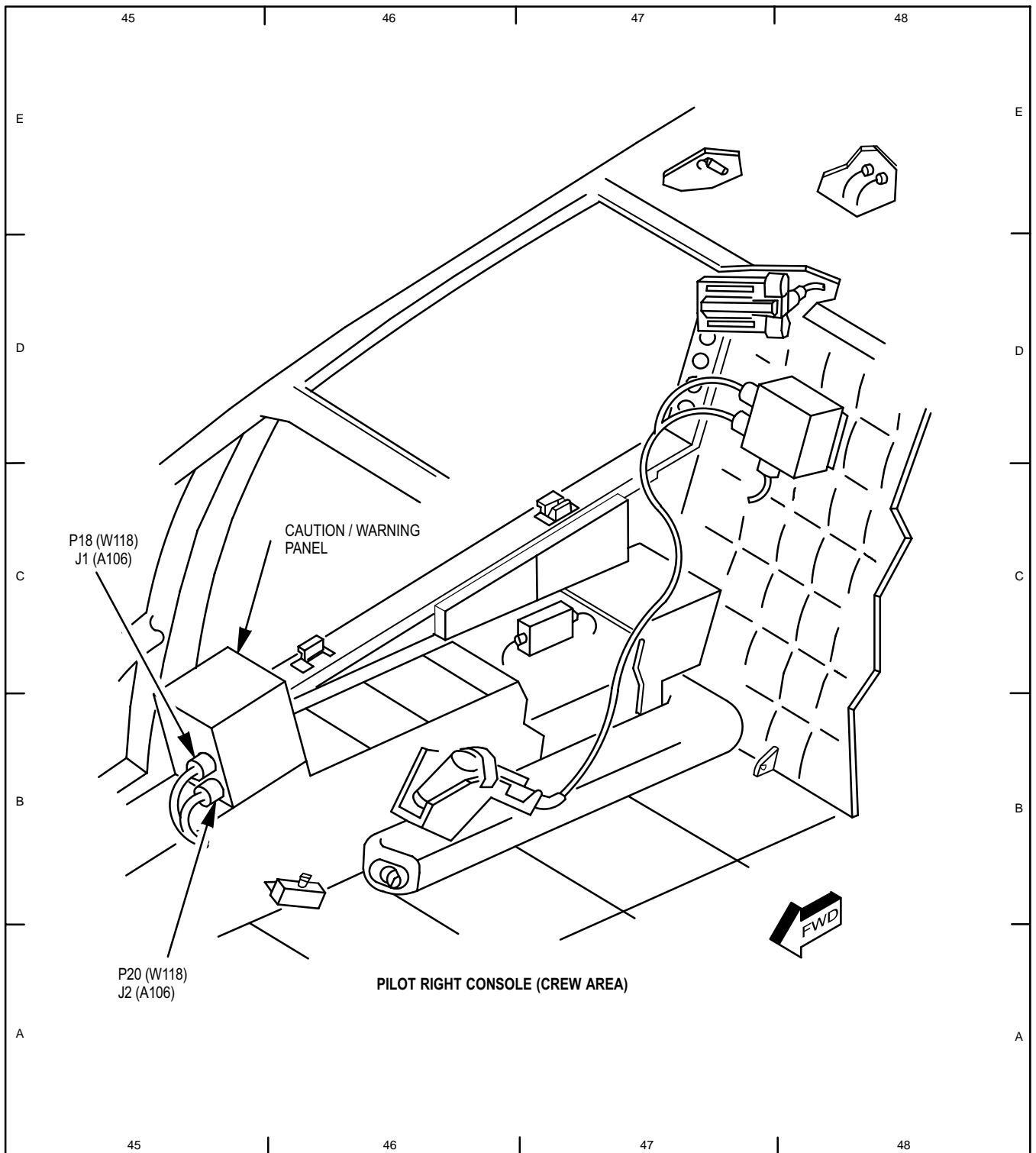

M71-255A

Table 12-2. Electrical Component Location and Configuration (ECLC) Index Listing (cont)

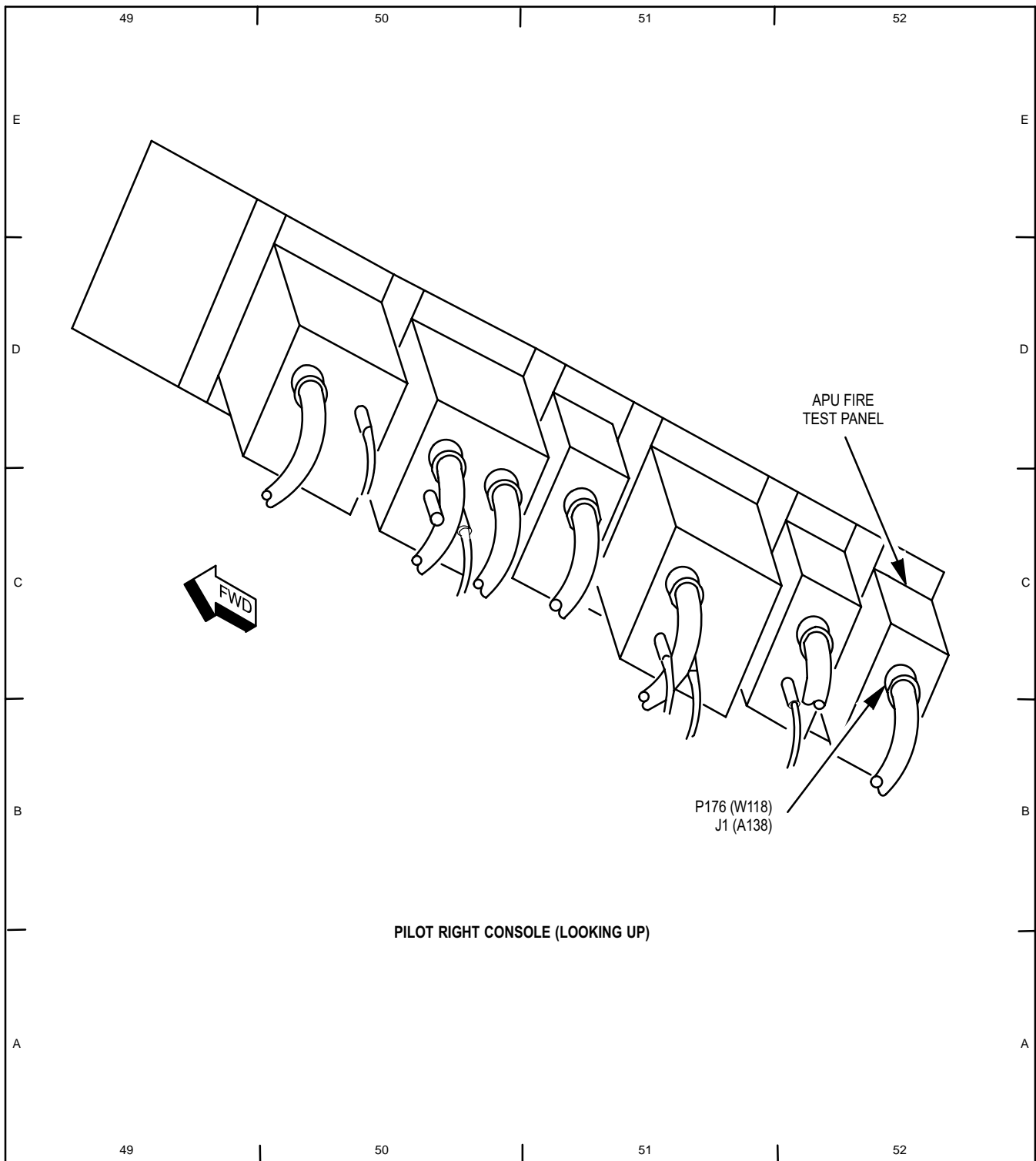

M71-254A

12-9. ELECTRICAL COMPONENT LOCATION AND CONFIGURATION (ECLC) INDEX (cont)

12-9

Table 12-2. Electrical Component Location and Configuration (ECLC) Index Listing (cont)

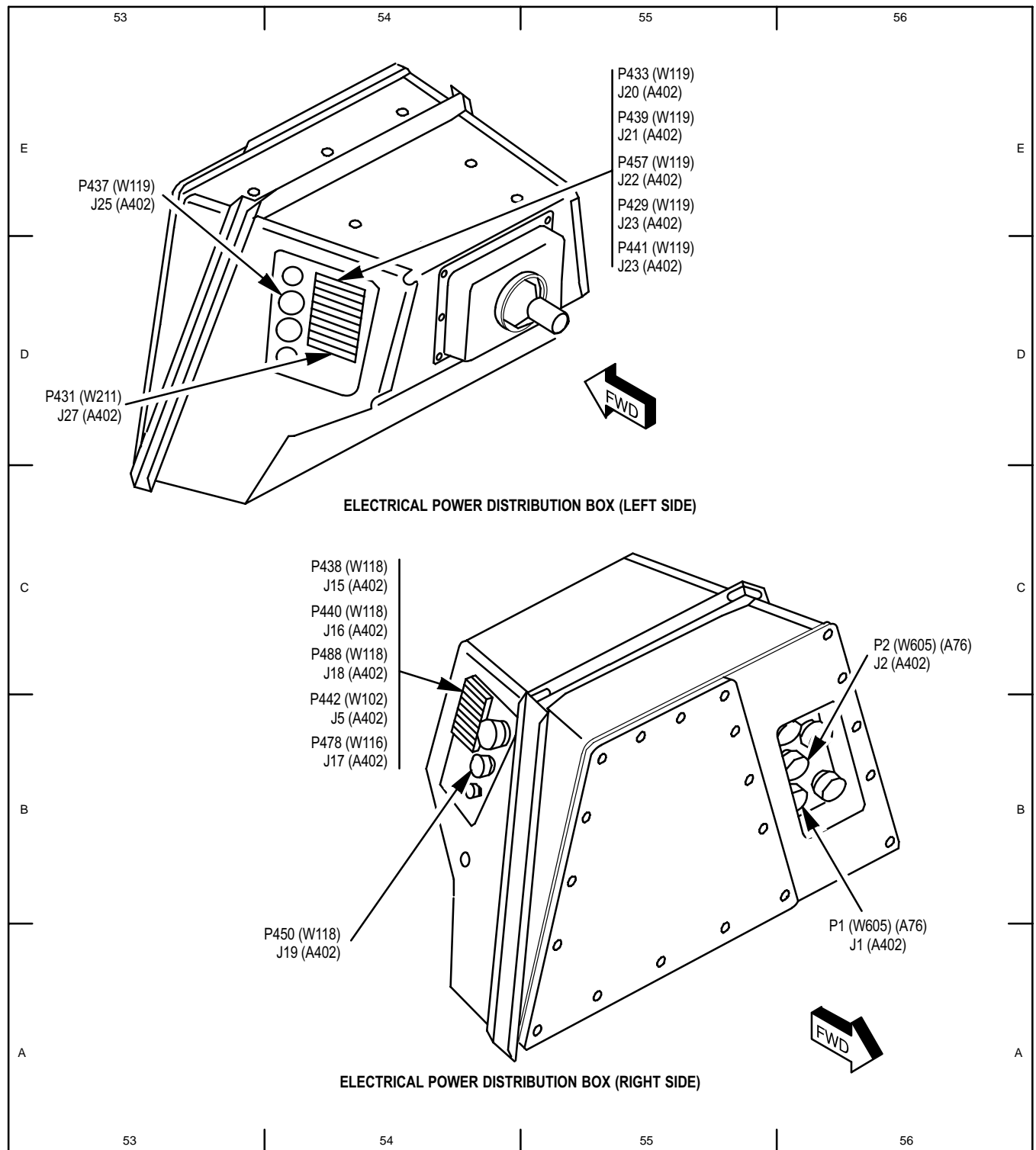

M71-258A

Table 12-2. Electrical Component Location and Configuration (ECLC) Index Listing (cont)

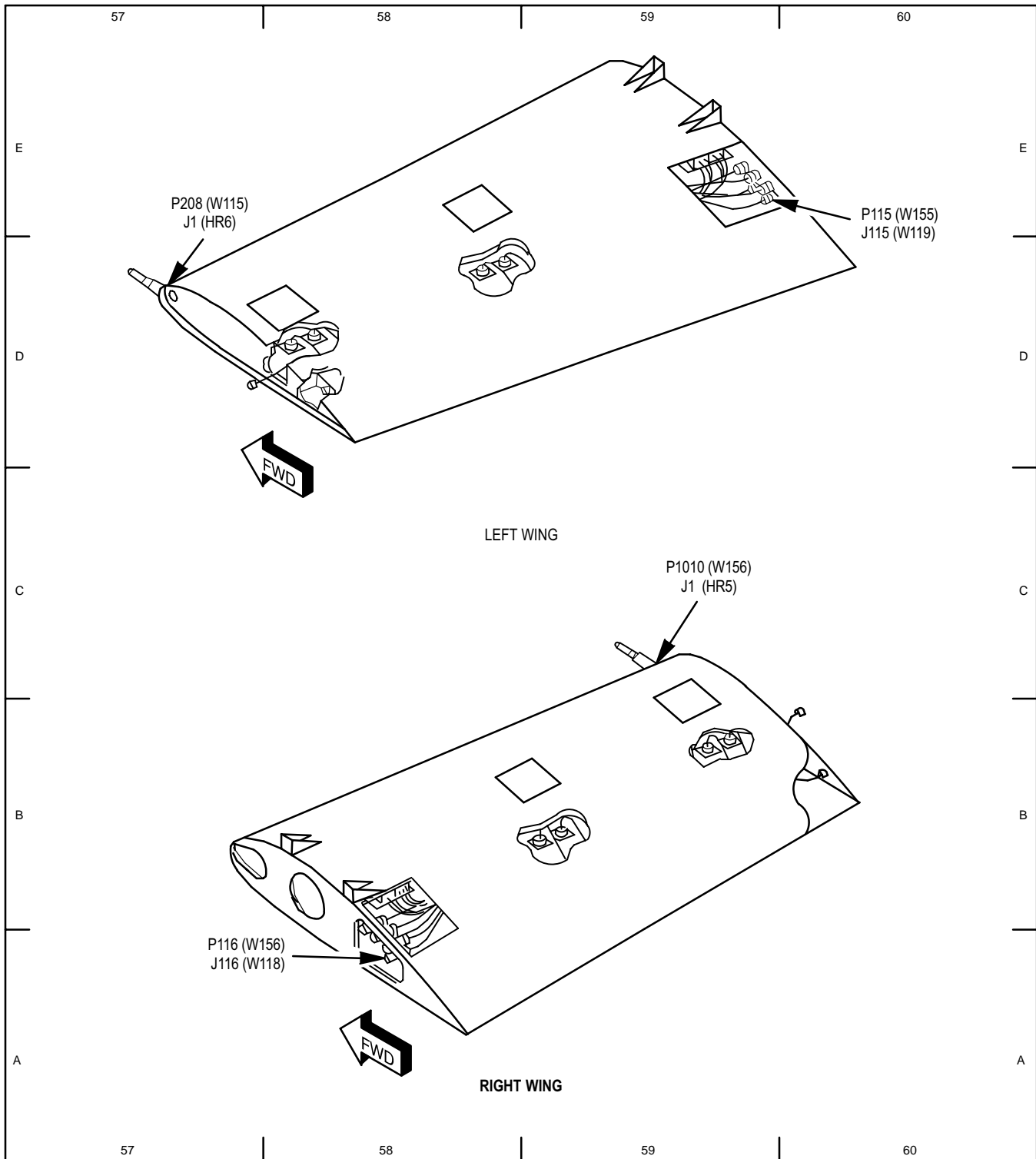

M71-271B

12-9. ELECTRICAL COMPONENT LOCATION AND CONFIGURATION (ECLC) INDEX (cont)

12-9

Table 12-2. Electrical Component Location and Configuration (ECLC) Index Listing (cont)

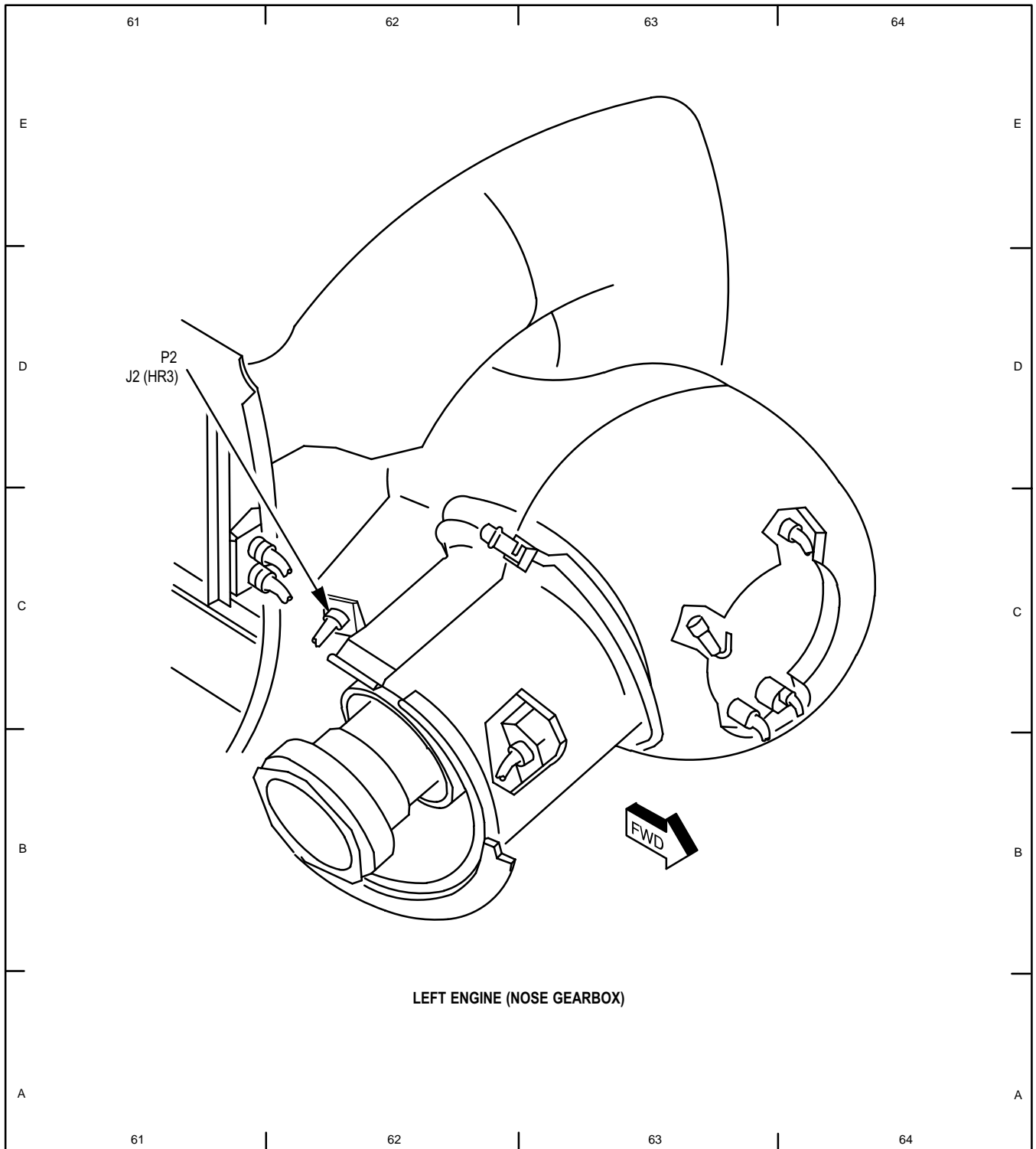

M71-276

Table 12-2. Electrical Component Location and Configuration (ECLC) Index Listing (cont)

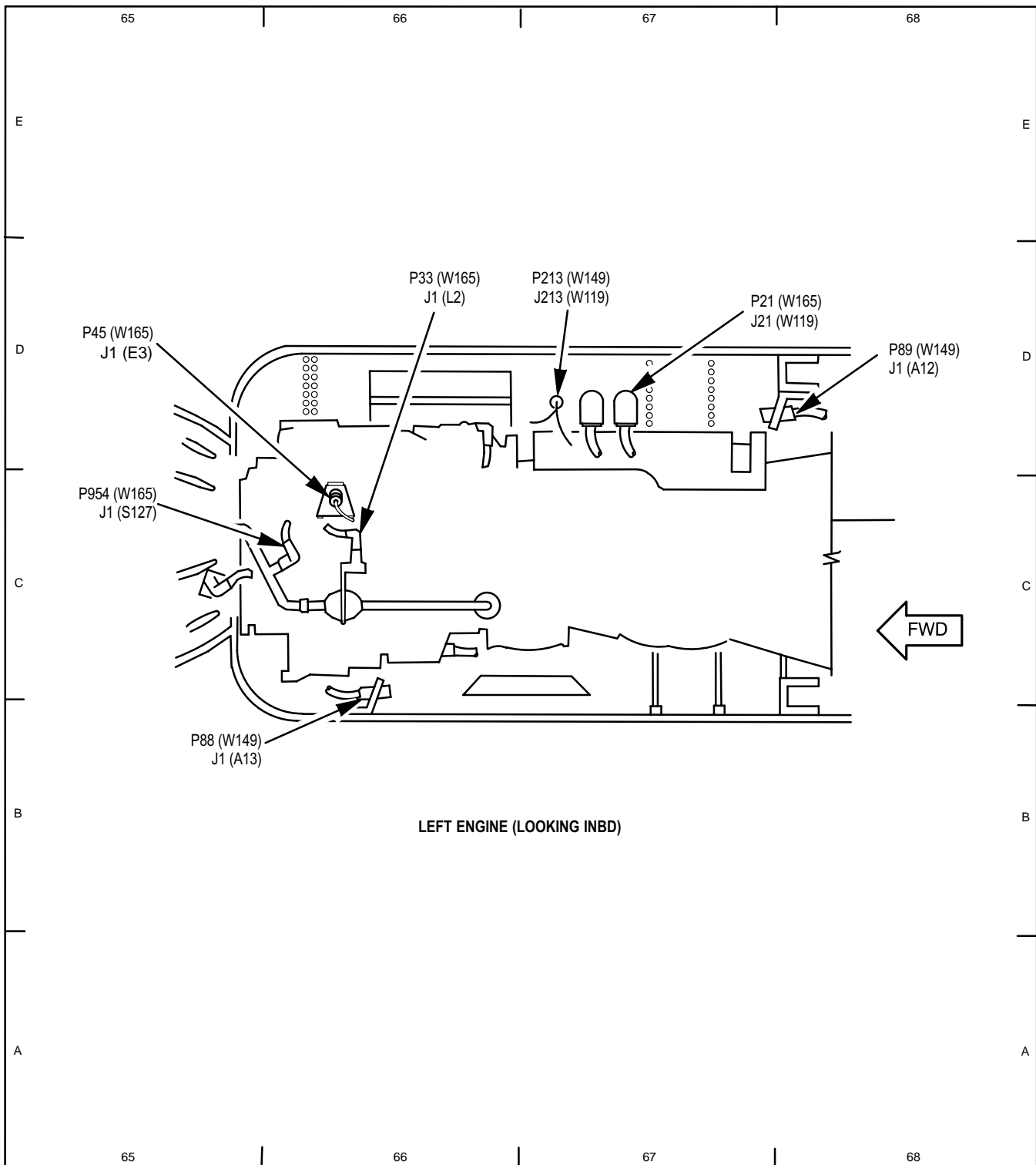

M71-277



12-9. ELECTRICAL COMPONENT LOCATION AND CONFIGURATION (ECLC) INDEX (cont)

12-9

Table 12-2. Electrical Component Location and Configuration (ECLC) Index Listing (cont)

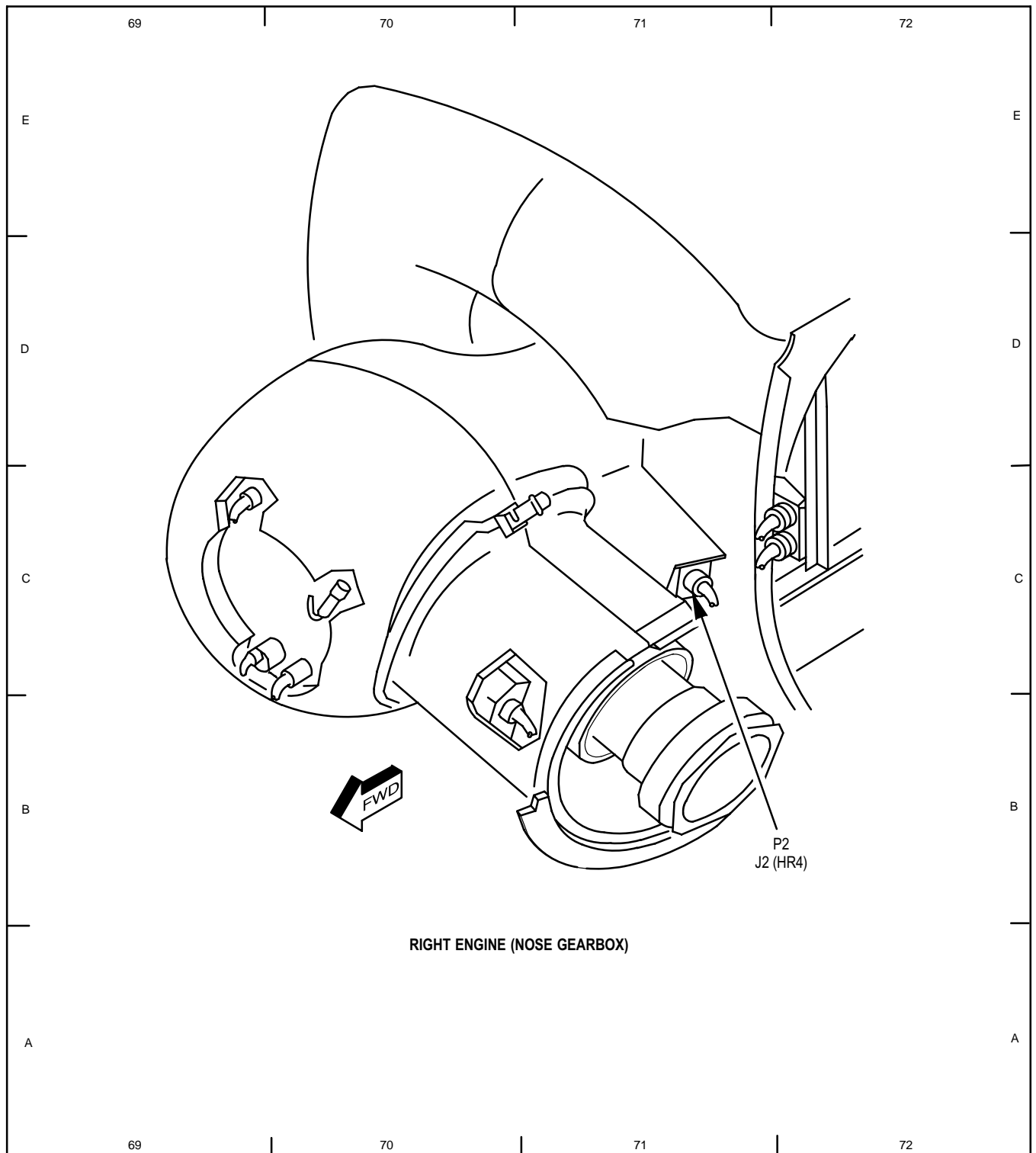

M71-278

**Table 12-2. Electrical Component Location and Configuration (ECLC) Index Listing (cont)**

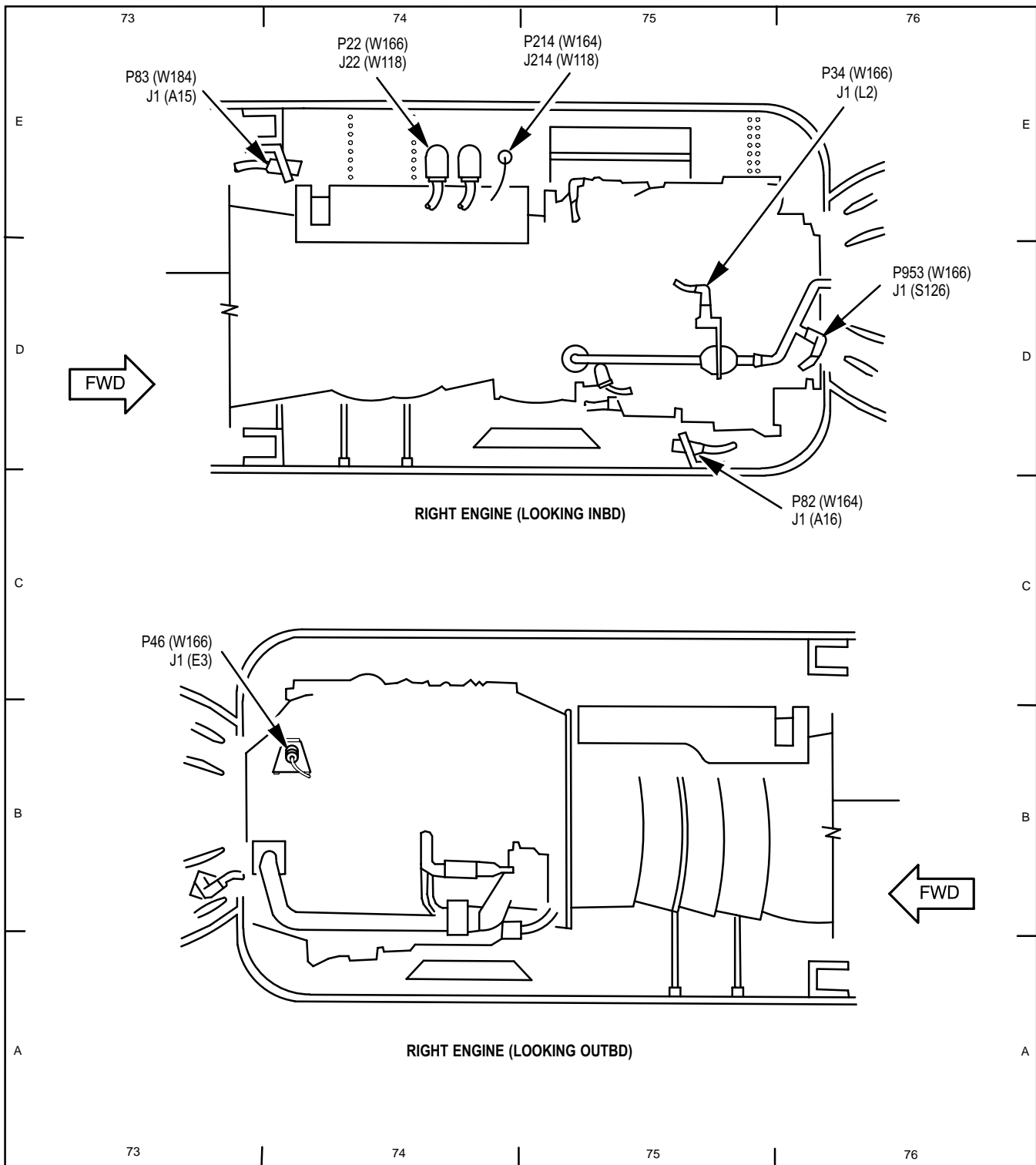

M71-279

12-9. ELECTRICAL COMPONENT LOCATION AND CONFIGURATION (ECLC) INDEX (cont)

12-9

Table 12-2. Electrical Component Location and Configuration (ECLC) Index Listing (cont)

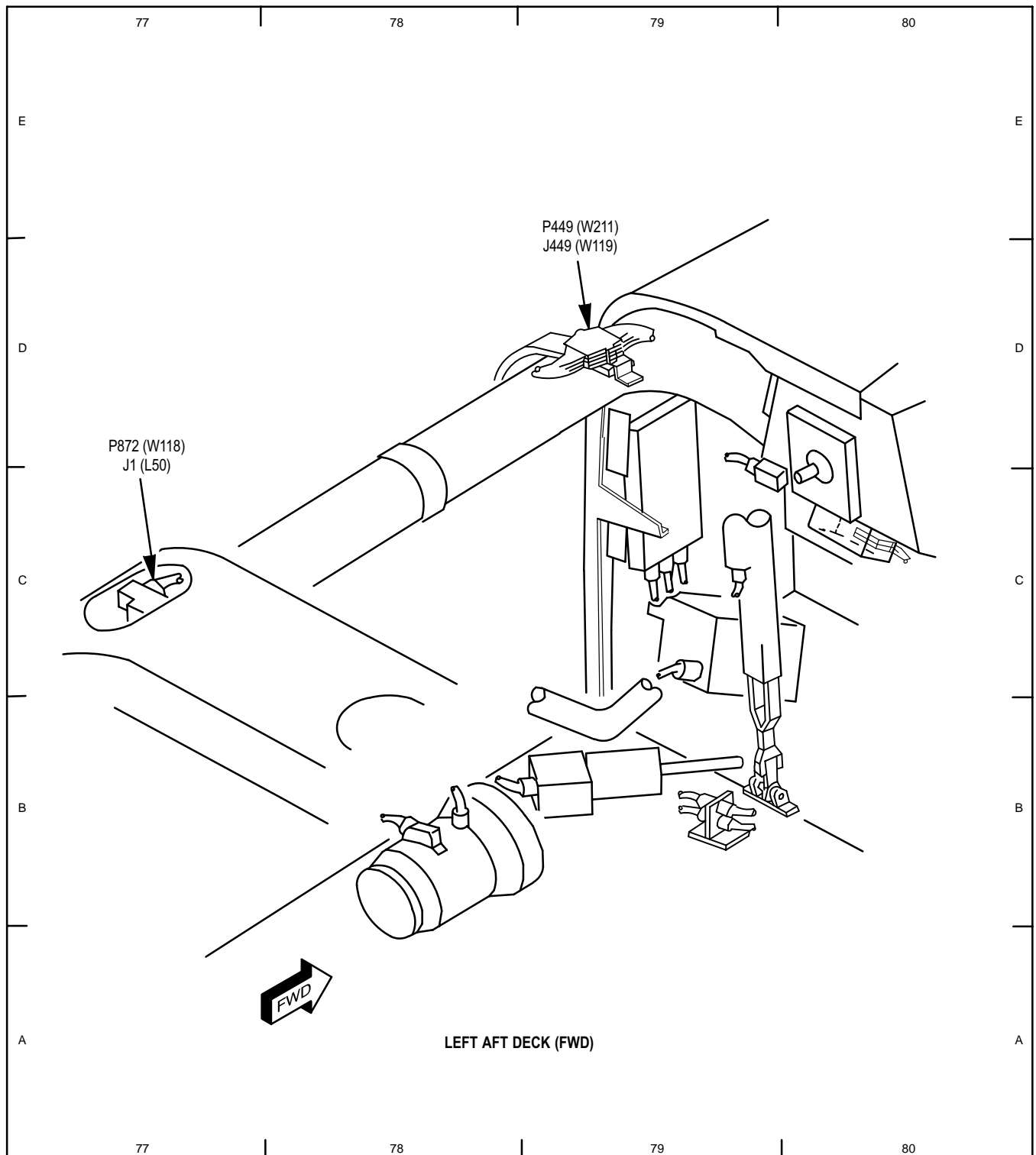

M71-280

Table 12-2. Electrical Component Location and Configuration (ECLC) Index Listing (cont)

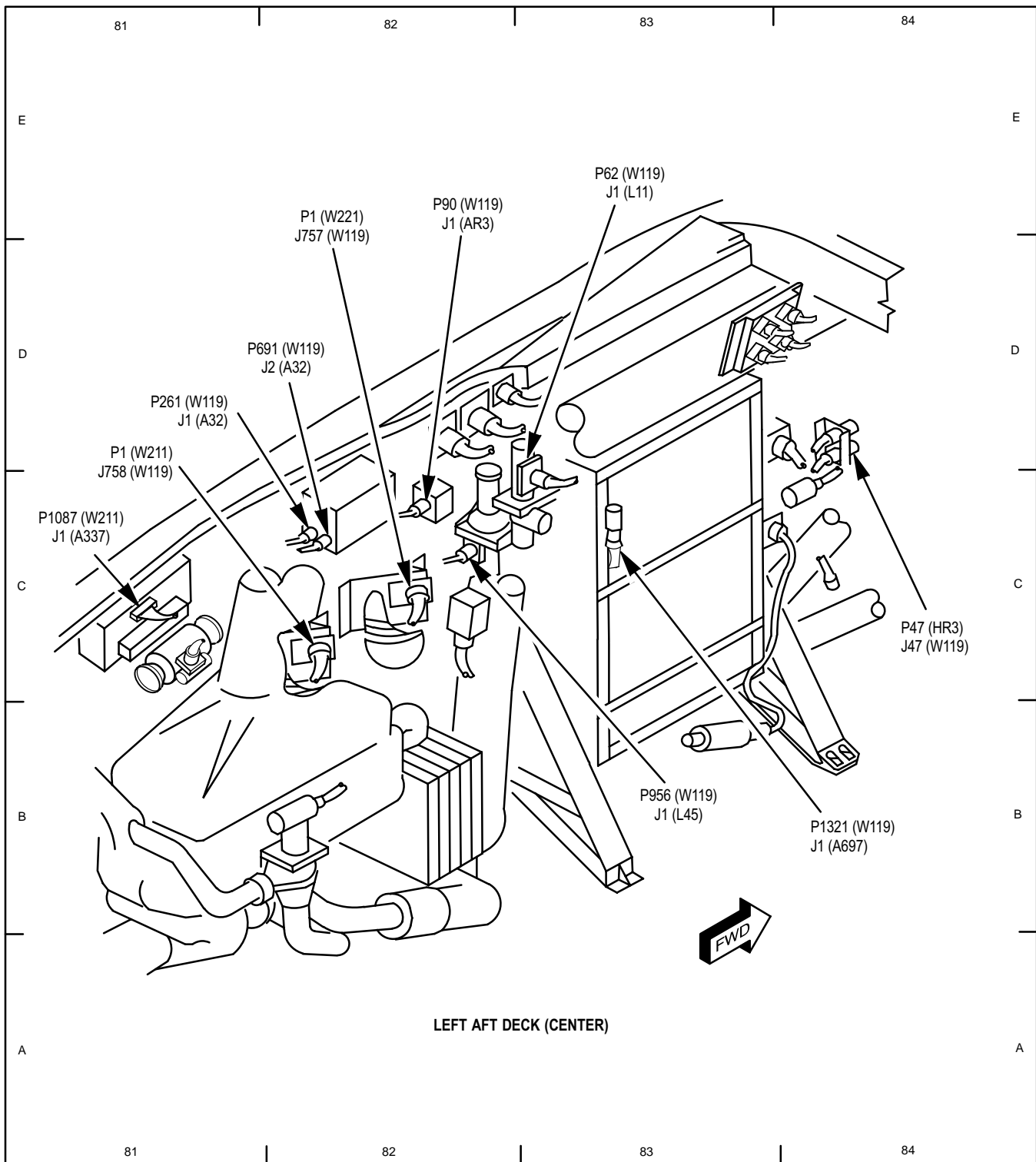

M71-265A

12-9. ELECTRICAL COMPONENT LOCATION AND CONFIGURATION (ECLC) INDEX (cont)

12-9

Table 12-2. Electrical Component Location and Configuration (ECLC) Index Listing (cont)

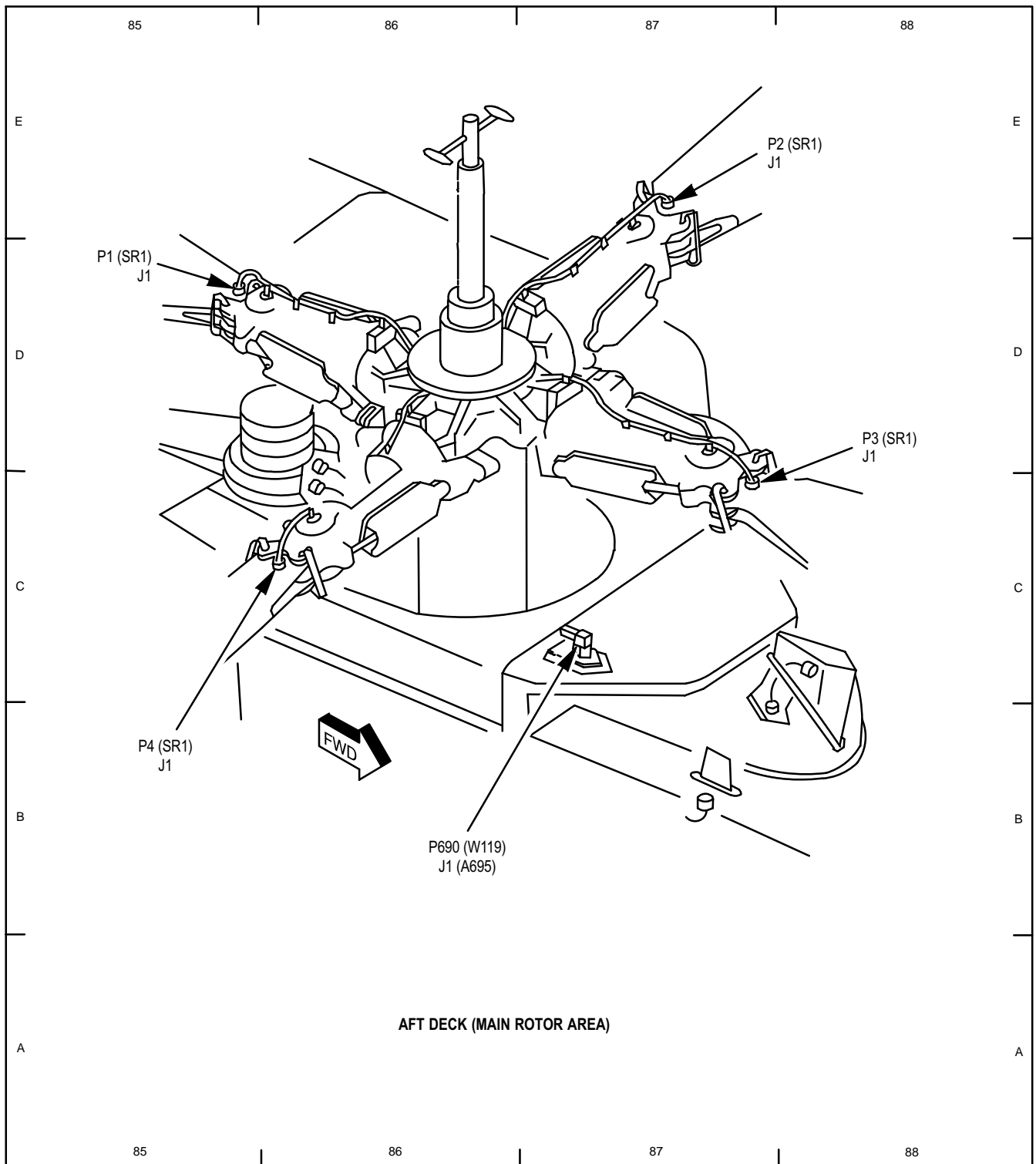

M71-264A

Table 12-2. Electrical Component Location and Configuration (ECLC) Index Listing (cont)

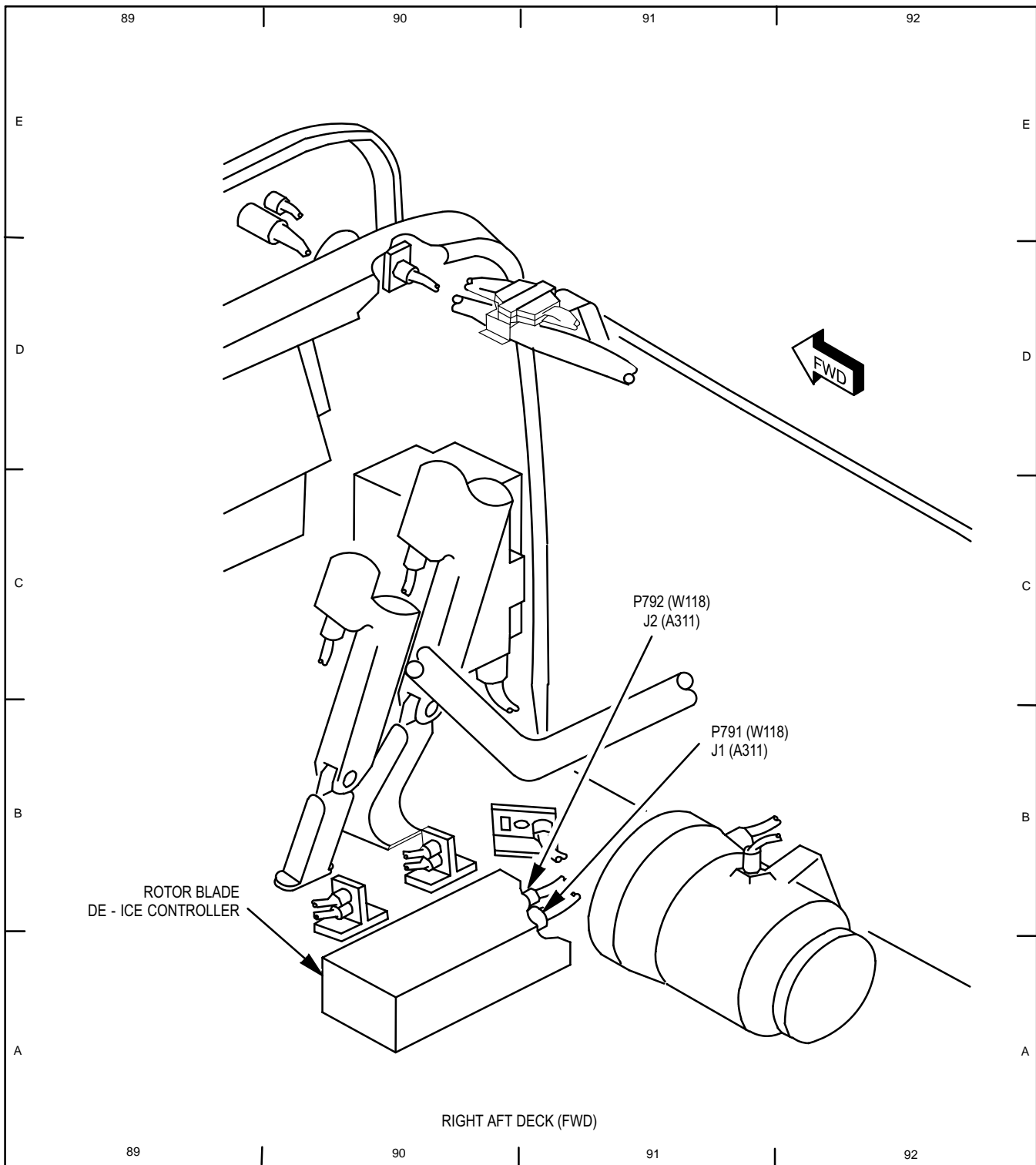

M71-261A

12-9. ELECTRICAL COMPONENT LOCATION AND CONFIGURATION (ECLC) INDEX (cont)

12-9

Table 12-2. Electrical Component Location and Configuration (ECLC) Index Listing (cont)

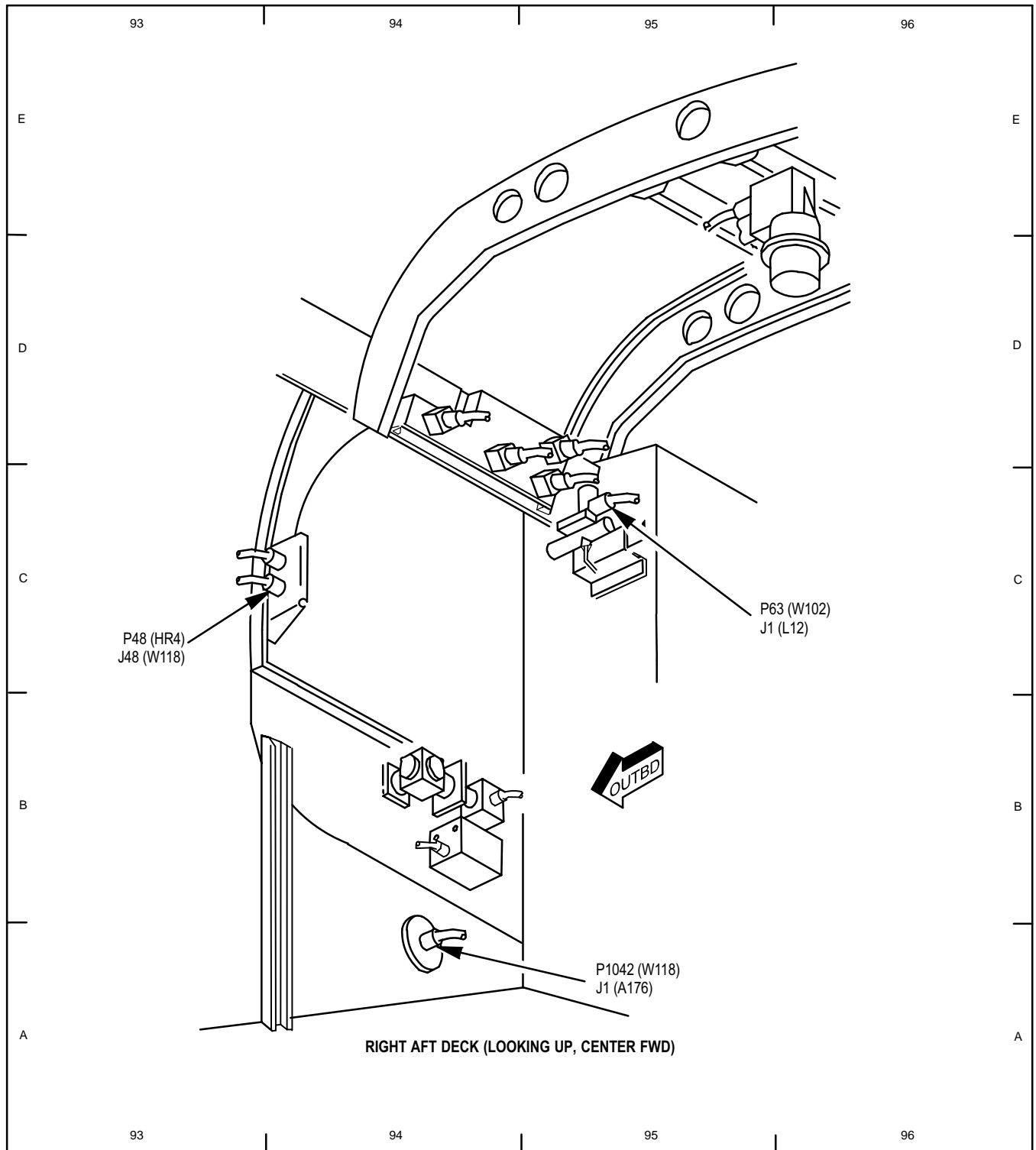

M71-262A

Table 12-2. Electrical Component Location and Configuration (ECLC) Index Listing (cont)

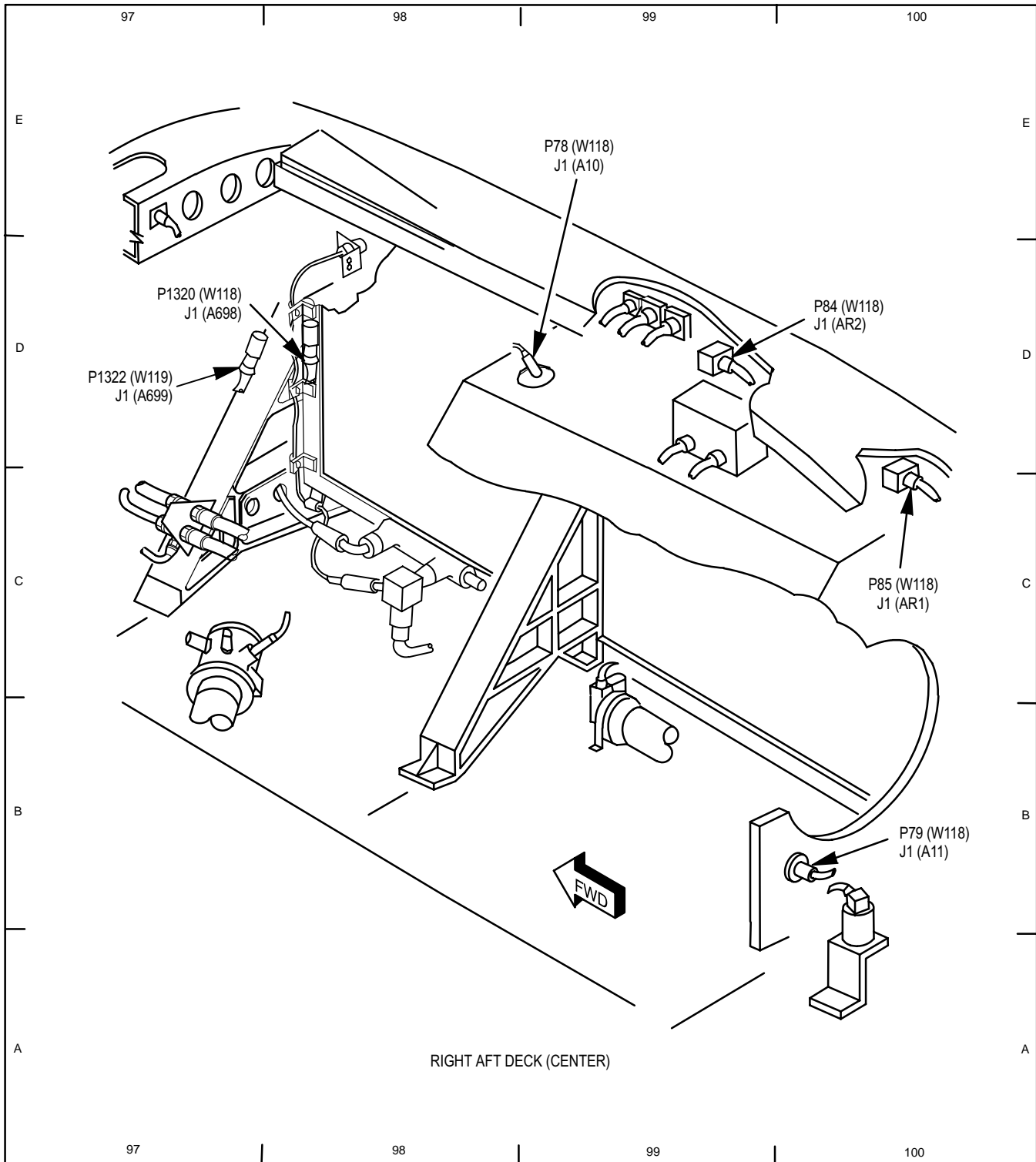

M71-263A



12-9. ELECTRICAL COMPONENT LOCATION AND CONFIGURATION (ECLC) INDEX (cont)

12-9

Table 12-2. Electrical Component Location and Configuration (ECLC) Index Listing (cont)

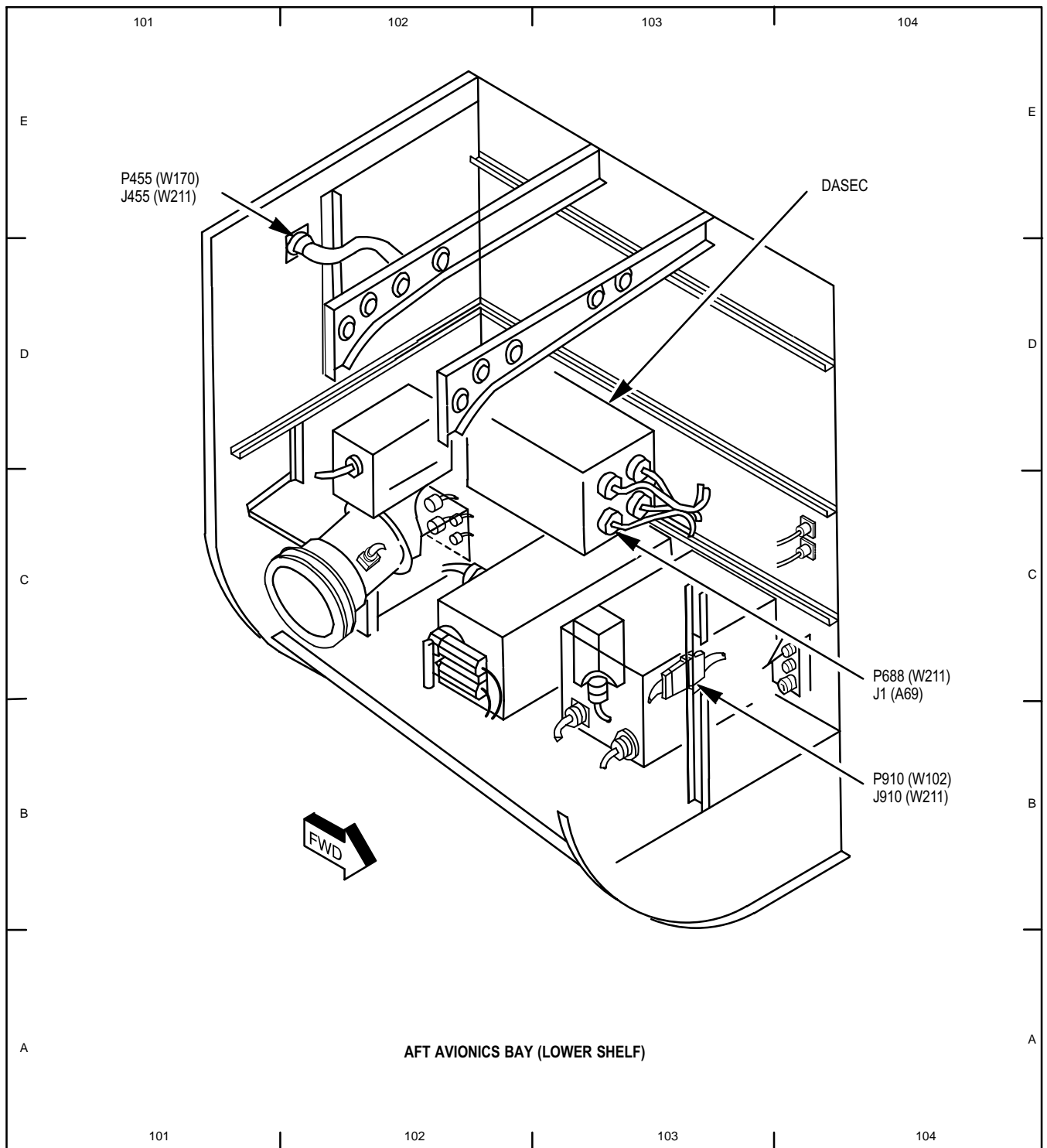

M71-266A

Table 12-2. Electrical Component Location and Configuration (ECLC) Index Listing (cont)

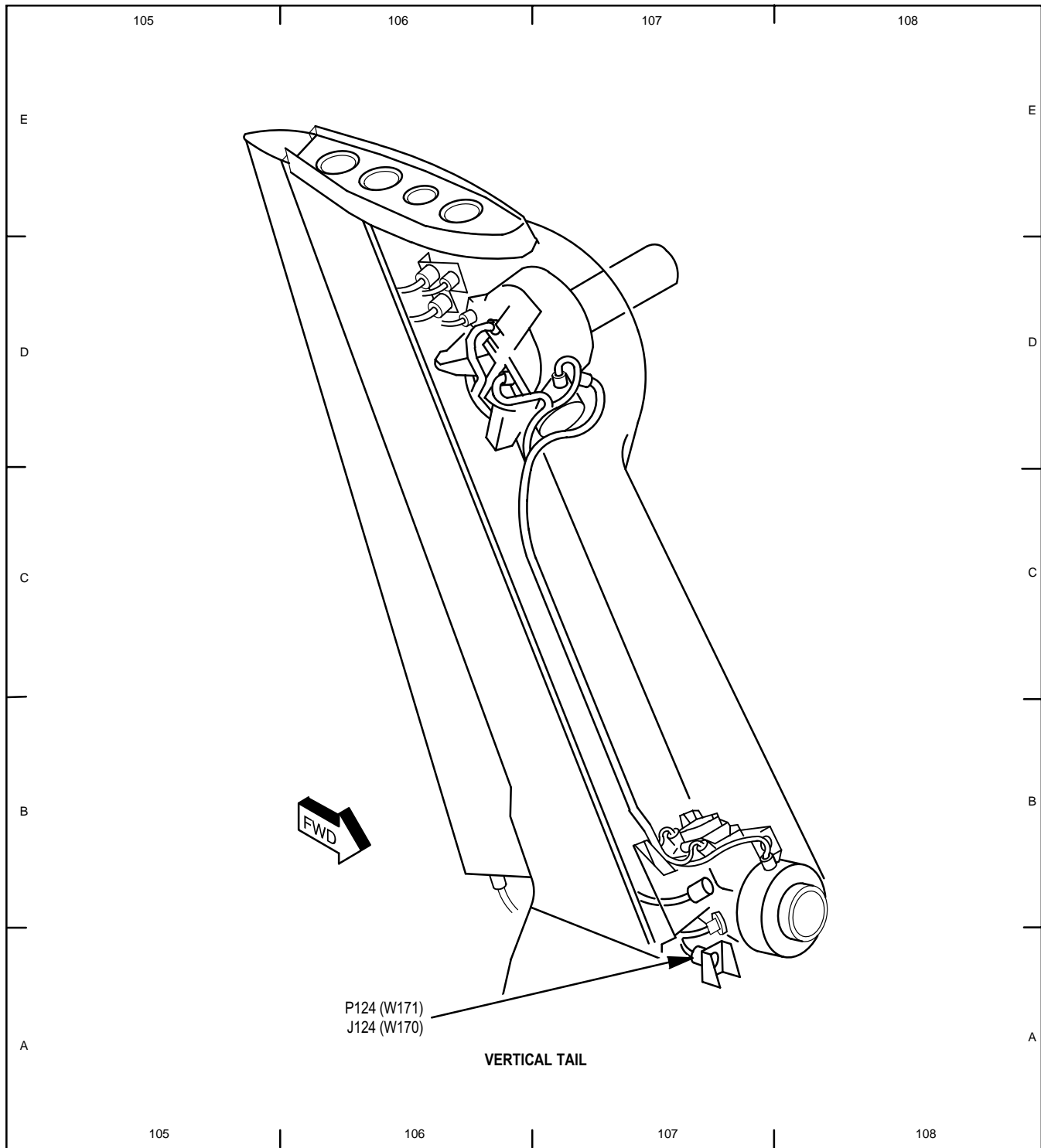

M71-268A

12-9. ELECTRICAL COMPONENT LOCATION AND CONFIGURATION (ECLC) INDEX (cont)

12-9

Table 12-2. Electrical Component Location and Configuration (ECLC) Index Listing (cont)

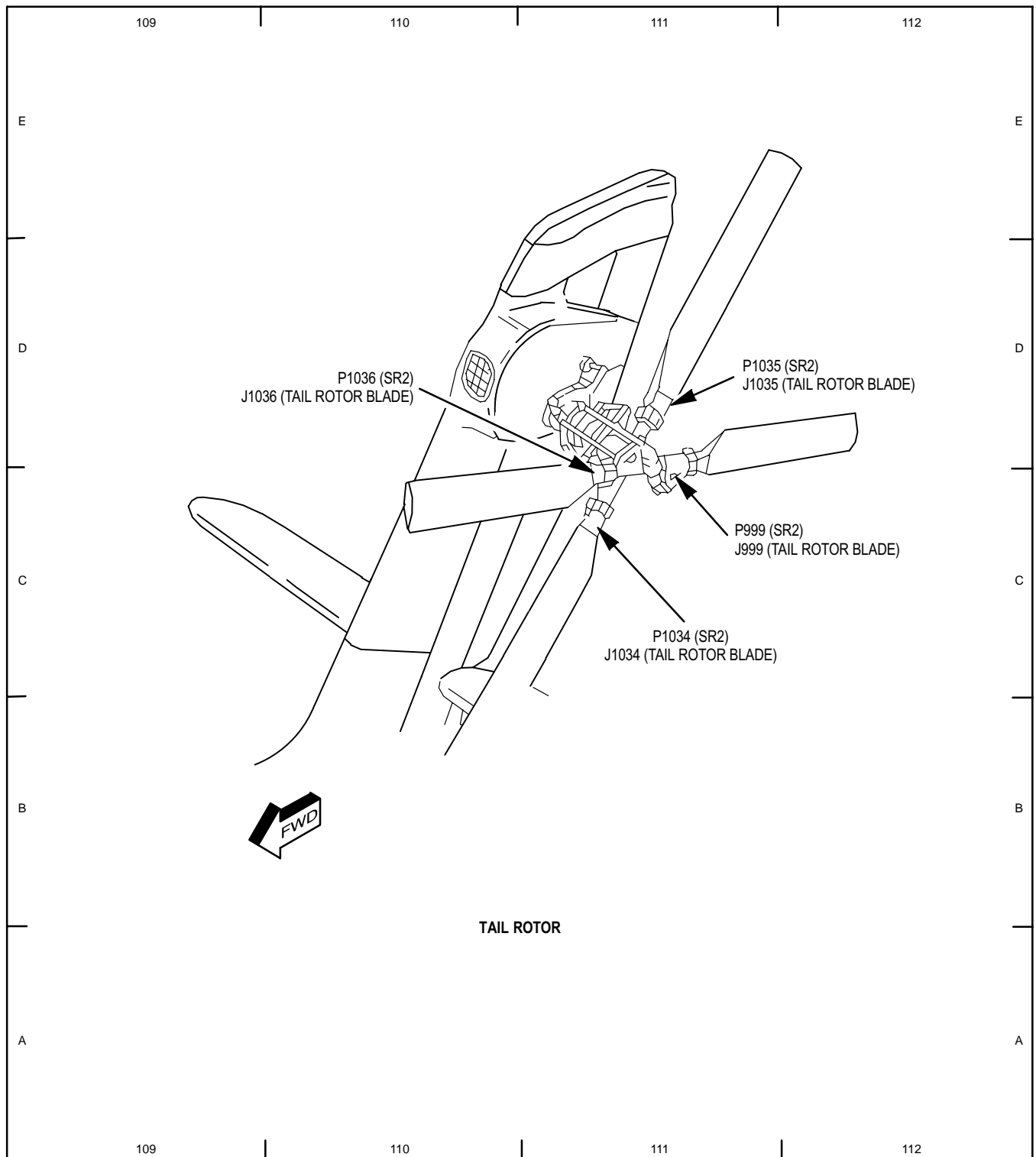

M71-281

12-10. CANOPY DEFOG AND ANTI-ICE - POWER UP

12-10

**Tools:**

Nomenclature	Part Number
Tool Kit, Aircraft Mechanic's	SC518099CLA01

**Equipment Conditions:**

Ref	Condition
TM 1-1520-238-23	Helicopter safed External power application - Electrical - Pressurized air Canopy anti-ice system inspection completed

**Personnel Required:**

67R Attack Helicopter Repairer

**References:**

TM 1-1520-238-23

**NOTE**

Refer to pilot station (fig. 12-40) and CPG station (fig. 12-41) for cockpit configuration and equipment.

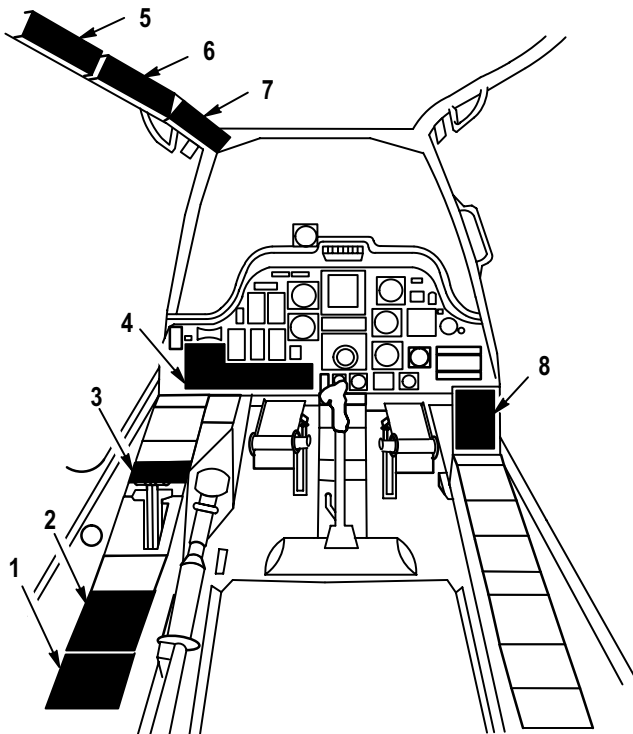

1. PILOT ANTI ICE PANEL
2. PILOT EXT LT/INTR LT PANEL
3. PILOT ELEC PWR PANEL
4. PILOT FIRE CONTROL PANEL
5. PILOT AFT CIRCUIT BREAKER PANEL
6. PILOT CENTER CIRCUIT BREAKER PANEL
7. PILOT FORWARD CIRCUIT BREAKER PANEL
8. PILOT CAUTION/WARNING PANEL

M71-009

Figure 12-40. Pilot Station

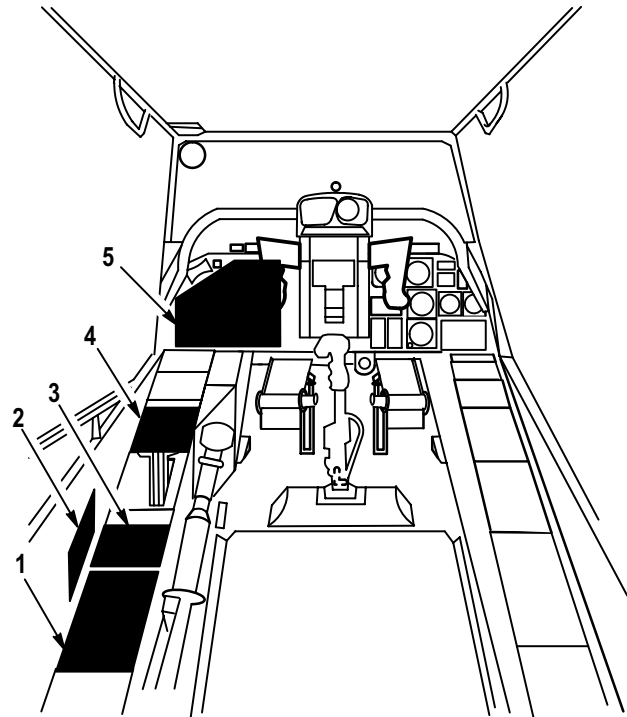

1. CPG CIRCUIT BREAKER PANEL 1
2. CPG CIRCUIT BREAKER PANEL 2
3. CPG INTR LT PANEL
4. CPG AUX/ANTI-ICE PANEL
5. CPG FIRE CONTROL PANEL

M71-010A

Figure 12-41. CPG Station

12-10. CANOPY DEFOG AND ANTI-ICE - POWER UP (cont)

12-10

1. On pilot **ELEC PWR** panel (fig. 12-42), set **BATT/EXT PWR** switch to **EXT PWR**.

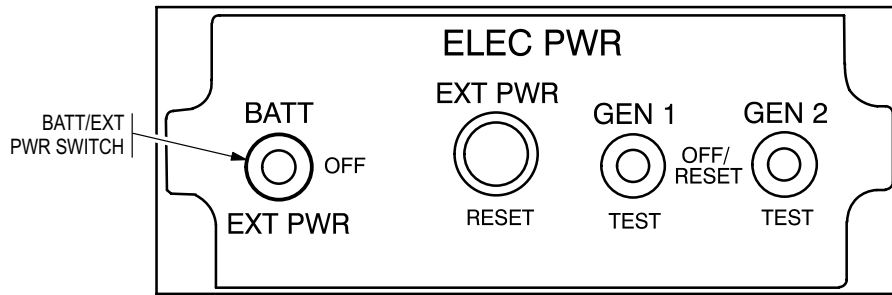

M71-011

Figure 12-42. Pilot ELEC PWR Panel

2. On pilot circuit breaker panels (fig. 12-43), check that the following circuit breakers are closed:

<u>Circuit Breaker Panel</u>	<u>Circuit Breaker</u>	<u>Circuit Breaker Panel</u>	<u>Circuit Breaker</u>
Forward	<b>MISSION FC DC</b>	Aft	<b>ECS AFT FAN</b>
Forward	<b>MISSION FC AC</b>	Aft	<b>ECS FAB FANS</b>
Center	<b>LT CAUT</b>	Aft	<b>ECS CAB</b>
Center	<b>LT PRI</b>	Aft	<b>ECS CANOPY ANTI-ICE CONTR</b>
Aft	<b>ECS CANOPY ANTI-ICE</b>		

3. On CPG circuit breaker panel 1 (fig. 12-44), check that the following circuit breakers are closed:

<u>Circuit Breaker</u>	<u>Circuit Breaker</u>
<b>MUX CPG</b>	<b>FC FCC DC</b>
<b>MUX FAB L</b>	<b>FC FCC AC</b>

4. On CPG **FIRE CONTROL** panel (fig. 12-45), set **PLT/GND** switch to **ORIDE**.

12-10. CANOPY DEFOG AND ANTI-ICE - POWER UP (cont)

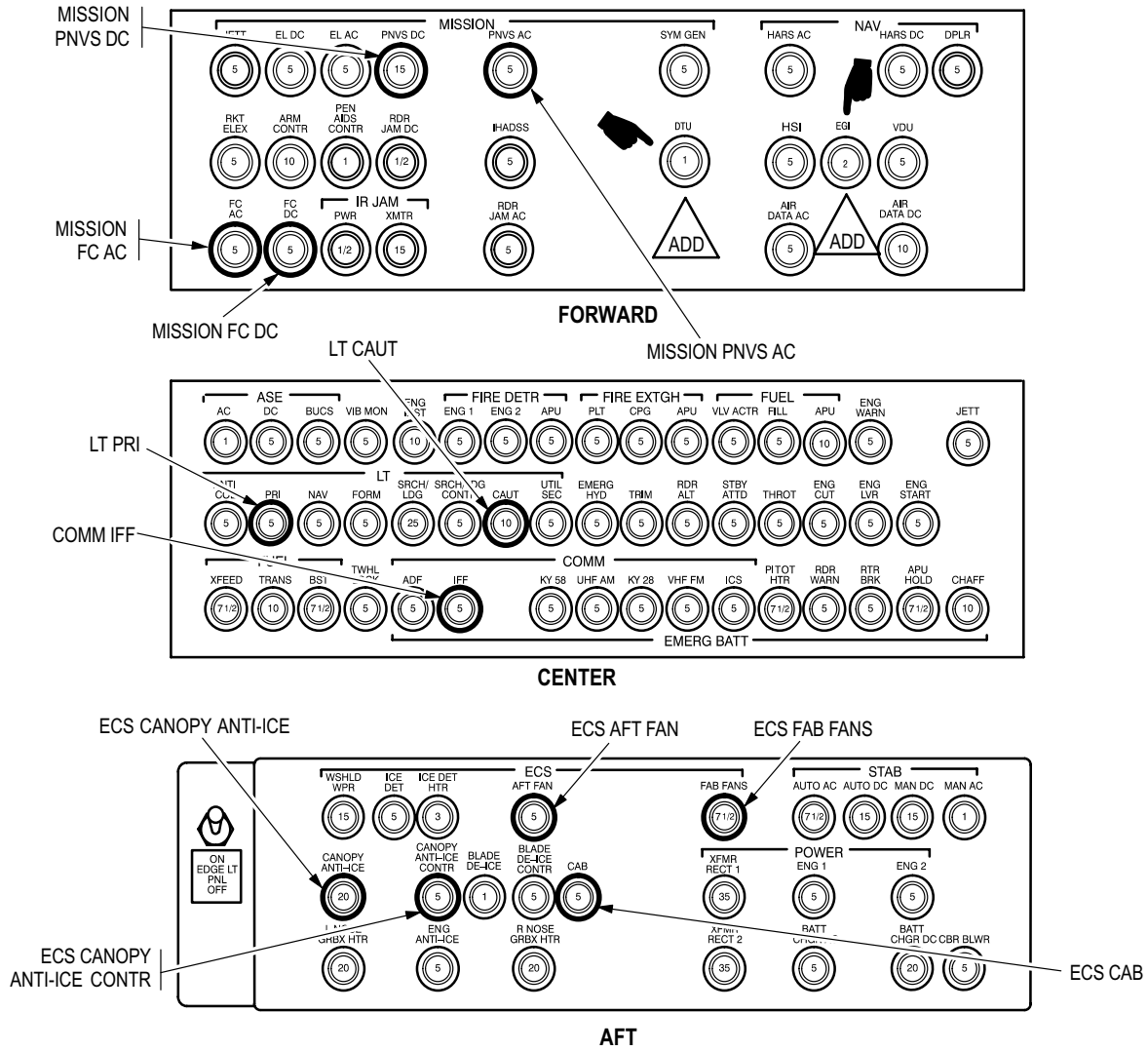
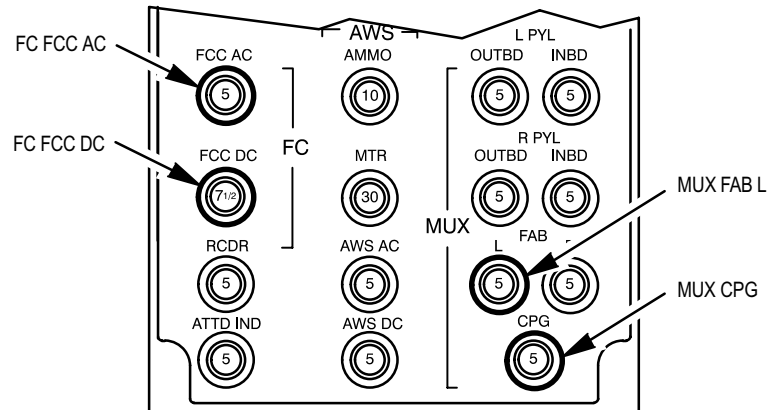

Figure 12-43. Pilot Circuit Breaker Panels

M71-014A



M71-015

Figure 12-44. CPG Circuit Breaker Panel 1

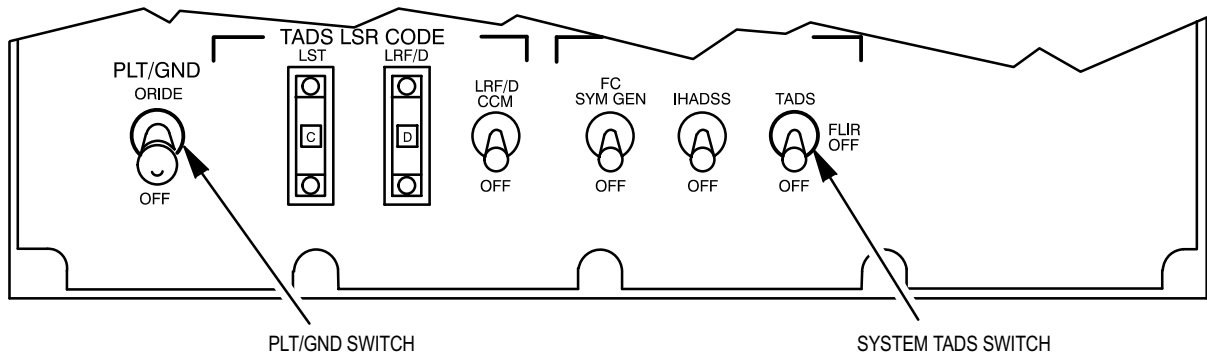

M71-016

Figure 12-45. CPG FIRE CONTROL Panel

---

**12-1 1. CANOPY DEFOG AND ANTI-ICE - POWER DOWN**

---

**12-1 1****Tools:**NomenclaturePart NumberTool Kit, Aircraft  
Mechanic's

SC518099CLA01

**References:**

TM 1-1520-238-23

**Equipment Conditions:**Ref

Paragraph 12-10

ConditionCANOPY DEFOG and  
ANTI-ICE - POWER UP  
completed**Personnel Required:**

67R Attack Helicopter Repairer

---

**NOTE**

Refer to pilot station (fig. 12-40) and CPG station (fig. 12-41) for cockpit configuration and equipment.

1. On CPG **FIRE CONTROL** panel (fig. 12-45), set **PLT/GND** switch to **OFF**.
2. On pilot **ELEC PWR** panel (fig. 12-42), set **BATT/EXT PWR** switch to **OFF**.
3. Remove external power - electrical (TM 1-1520-238-23).

END OF TASK



**12-12. CANOPY DEFOG AND ANTI-ICE - MAINTENANCE OPERATIONAL CHECK**

**12-12**

**Tools:**

<u>Nomenclature</u>	<u>Part Number</u>
Tool Kit, Aircraft Mechanic's Fixture, Squat Switch	SC518099CLA01  7-3621MF002 Make item (TM 1-1520-238-23)

**References:**

TM 1-1520-238-T-1  
TM 1-1520-238-T-4  
TM 1-1520-238-23

**Equipment Conditions:**

<u>Ref</u>	<u>Condition</u>
Paragraph 12-10	CANOPY DEFOG and ANTI-ICE - POWER UP completed
TM 1-1520-238-T-4	Maintenance headset connected

**Personnel Required:**

67R Attack Helicopter Repairer  
One person to assist

**NOTE**

- Refer to pilot station (fig. 12-40) and CPG station (fig. 12-41) for cockpit configuration and equipment.
- If referenced out of one paragraph or volume and into another for additional troubleshooting, upon completion of the task, return to the maintenance operational check for the original paragraph or volume.

1. Perform the maintenance operational check as follows:

<u>Task</u>	<u>Result</u>
a. Perform De-Ice FD/LS check (TM 1-1520-238-T-1).	

**NOTE**

If a discrepancy is noted during the FD/LS check, perform corrective action indicated in TM 1-1520-238-T-1. If the discrepancy still exists after performing the corrective action required, refer to the following listed failure symptoms and perform troubleshooting.

If **CANOPY TEMP CONTROLLER NO-GO CPG COMPARTMENT** appears on HOD and no fault is found during FD/LS check, go to paragraph 12-20 and perform troubleshooting.

If **CANOPY TEMP SENSOR NO-GO CPG FR WINDSHIELD** appears on HOD and no fault is found during FD/LS check, go to paragraph 12-21 and perform troubleshooting.

12-12. CANOPY DEFOG AND ANTI-ICE - MAINTENANCE OPERATIONAL CHECK (cont)

12-12

Task	Result
------	--------

- |   |  |
|---|--|
| <p>b. On pilot <b>EXT LT/INTR LT</b> panel (fig. 12-46), rotate <b>L CSL</b> control between <b>OFF</b> and <b>BRT</b>.</p> | <p>If pilot <b>ANTI ICE</b> panel edge-light does not brighten, go to paragraph 12-14.</p> |
|---|--|

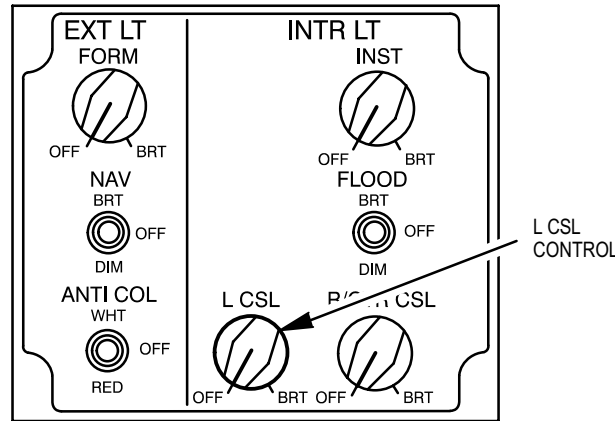

M71-017

Figure 12-46. Pilot EXT LT/INTR LT Panel

- |  |  |
|--|--|
| <p>c. On CPG <b>INTR LT</b> panel (fig. 12-47), rotate <b>L CSL</b> control between <b>OFF</b> and <b>BRT</b>.</p> | <p>If CPG <b>AUX/ANTI-ICE</b> panel edge-light does not brighten, go to paragraph 12-15.</p> |
|--|--|

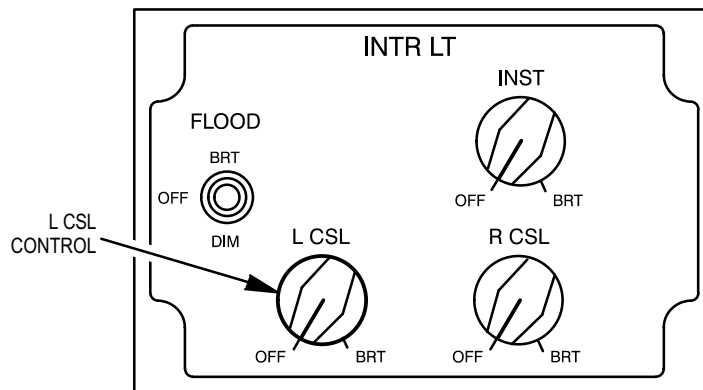

M71-018

Figure 12-47. CPG INTR LT Panel

- d. On pilot **ANTI ICE** panel (fig. 12-48), check that **CANOPY DEFOG** and **CANOPY HTR** switches are set to **OFF**. Place palm of hand on pilot windshield and check surface temperature for reference.

12-12. CANOPY DEFOG AND ANTI-ICE - MAINTENANCE OPERATIONAL CHECK (cont)

12-12

Task	Result
------	--------



**Do not heat canopy any longer than required for testing when air temperature is above icing condition. Prolonged heating in warm air can crack or deform windshields.**

- e. On pilot **ANTI ICE** panel (fig. 12-48), set **CANOPY DEFOG** and **CANOPY HTR** switches to **ON**. Place hands near air mixer outlets to check for defog air flow.

If no air flows (defog shutoff valve does not operate), go to paragraph 12-16.

If **CANOPY ANTI ICE FAIL** indicator on pilot caution/warning panel (fig. 12-49) lights, go to paragraph 12-22.

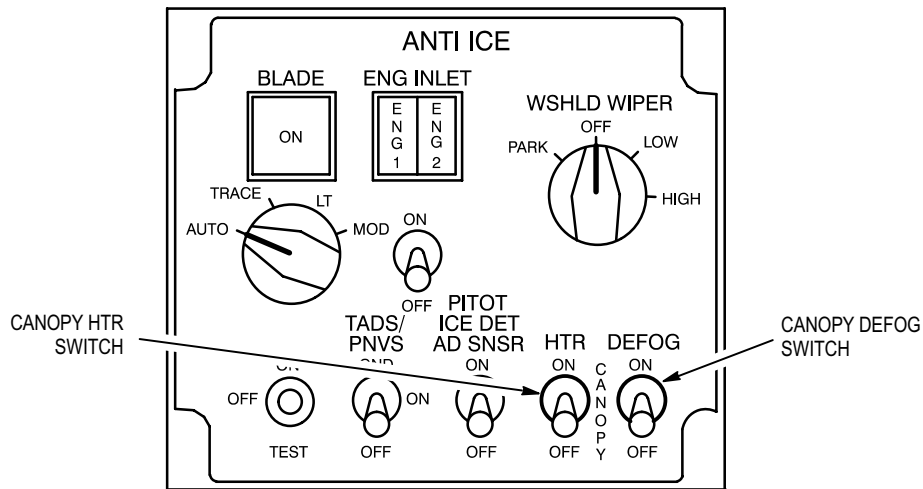

M71-019

Figure 12-48. Pilot ANTI ICE Panel

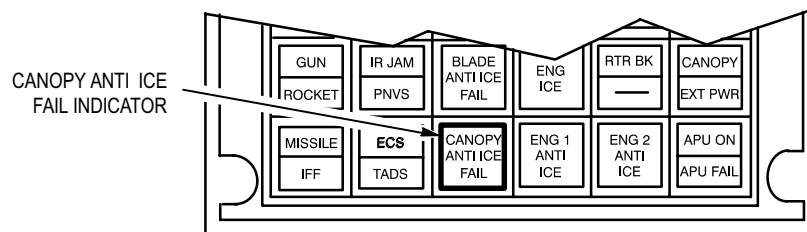

M71-020

Figure 12-49. Pilot Caution/Warning Panel

- f. On pilot **ANTI ICE** panel, set **CANOPY DEFOG** switch to **OFF**. Place hands near air mixer outlets to check for defog air shutoff.

If defog air does not shut off (defog shutoff valve does not operate), go to paragraph 12-16.

12-12. CANOPY DEFOG AND ANTI-ICE - MAINTENANCE OPERATIONAL CHECK (cont)

12-12

Task	Result
------	--------

**NOTE**

**When canopy is heated, windshields get warm but not too hot to touch.**

- |   |   |
|---|---|
| <p>g. Place palm of hand on pilot windshield and on CPG windshield to check for canopy heat.</p>  | <p>If windshields do not get warm (canopy windshield heaters do not heat), go to paragraph 12-19.</p>   |
| <p>h. On pilot <b>ANTI ICE</b> panel (fig. 12-48), set <b>CANOPY HTR</b> switch to <b>ON</b>. On pilot aft circuit breaker panel (fig. 12-43), ensure that <b>ECS CANOPY ANTI-ICE</b> and <b>ECS CANOPY ANTI-ICE CONTR</b> circuit breakers are closed.</p>                                 | <p>If <b>ECS CANOPY ANTI-ICE</b> circuit breaker does not stay closed, go to paragraph 12-17.</p> <p>If <b>ECS CANOPY ANTI-ICE CONTR</b> circuit breaker does not stay closed, go to paragraph 12-18.</p> |
| <p>i. On pilot <b>ANTI ICE</b> panel, set <b>CANOPY HTR</b> switch to <b>OFF</b>. On pilot aft circuit breaker panel, open <b>ECS CANOPY ANTI-ICE</b> and <b>ECS CANOPY ANTI-ICE CONTR</b> circuit breakers. After 3 minutes, place hand on windshields to check for cooling of canopy.</p> | <p>If windshields do not cool, replace canopy temperature controller (TM 1-1520-238-23).</p>  |

**WARNING**

**Do not touch PNVS shroud window. Electrical shock will result. If injury occurs, seek medical aid.**

**CAUTION**

**Do not touch PNVS shroud window. Touching shroud window makes cleaning necessary. Cleaning wears away protective coating on window.**

- j. On pilot center circuit breaker panel, open **COMM IFF** circuit breaker. Close **ECS CANOPY ANTI-ICE** circuit breaker. On pilot **ANTI ICE** panel, check that **TADS/PNVS** switch is set to **OFF**. On pilot **FIRE CONTROL** panel (fig. 12-50), check that **PNVS** switch is set to **OFF**, and **SIGHT SEL** switch is set to **STBY**. Place hand near top and sides of PNVS shroud window and check air temperature.
- k. Install squat switch fixture (TM 1-1520-238-23).

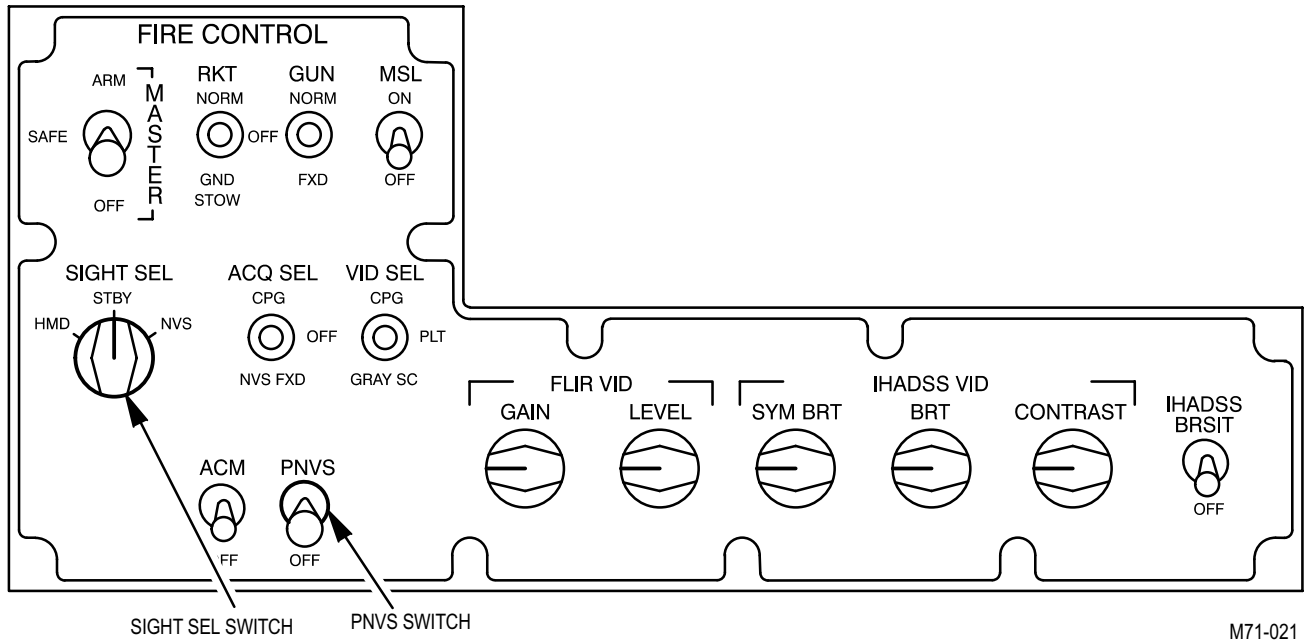

Figure 12-50. Pilot FIRE CONTROL Panel

Task	Result
<p>i. On pilot aft and forward circuit breaker panels (fig. 12-43), close <b>ECS CANOPY ANTI-ICE, MISSION PNVS DC, and MISSION PNVS AC</b> circuit breakers. On pilot <b>FIRE CONTROL</b> panel (fig. 12-50), set <b>PNVS</b> switch to <b>ON</b>. On pilot <b>ANTI ICE</b> panel (fig. 12-48), set <b>TADS/PNVS</b> switch to <b>GND</b>. Place hand near top and sides of PNVS shroud window to check for warmer air temperature.</p>	<p>If air temperature does not get warmer (PNVS shroud window heater does not heat), go to paragraph 12-23.</p>
<p><b>NOTE</b> External communication will not be available when COMM IFF circuit breaker is closed and squat switch fixture is installed.</p>	
<p>m. On pilot center circuit breaker panel, close <b>COMM IFF</b> circuit breaker. On pilot <b>ANTI ICE</b> panel, set <b>TADS/PNVS</b> switch to <b>ON</b>. Place hand near top and sides of PNVS shroud window to check air temperature.</p>	<p>If air temperature is not the same as in step i. (PNVS shroud window heater does not heat), go to paragraph 12-23.</p>

12-12. CANOPY DEFOG AND ANTI-ICE - MAINTENANCE OPERATIONAL CHECK (cont)

12-12

Task	Result
<p>n. On pilot <b>ANTI ICE</b> panel (fig. 12-48), set <b>TADS/PNVS</b> switch to <b>OFF</b>. On pilot <b>FIRE CONTROL</b> panel (fig. 12-50), set <b>PNVS</b> switch to <b>OFF</b>. On pilot center and forward circuit breaker panels (fig. 12-43), open <b>COMM IFF</b>, <b>MISSION PNVS DC</b> and <b>MISSION PNVS AC</b> circuit breakers. After 3 minutes, place hand near PNVS shroud windows to check for cooler air temperature.</p>	<p>If air temperature does not get cooler, go to paragraph 12-23.</p>

**WARNING**

Do not touch TADS shroud windows. Electrical shock will result.

**CAUTION**

Do not touch TADS shroud windows. Touching shroud windows makes cleaning necessary. Cleaning wears away protective coating on windows.

- o. On CPG **AUX/ANTI-ICE** panel (fig. 12-51), check that **TADS/PNVS** switch is set to **OFF**. On CPG **FIRE CONTROL** panel (fig. 12-45), check that **SYSTEM TADS** switch is set to **OFF**. Place hand near top and sides of TADS shroud windows and check air temperature.

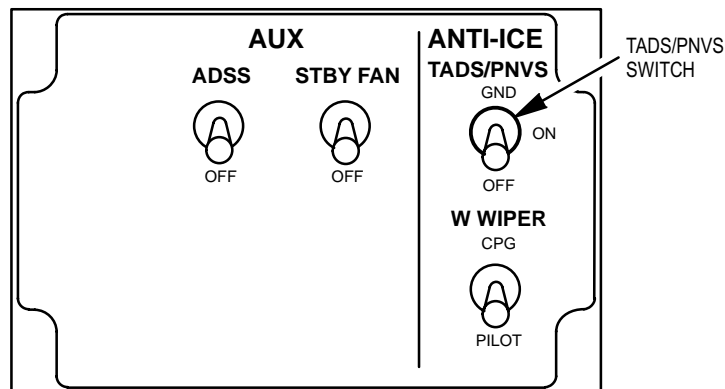

M71-023

Figure 12-51. CPG AUX/ANTI-ICE Panel

12-12. CANOPY DEFOG AND ANTI-ICE - MAINTENANCE OPERATIONAL CHECK (cont)

12-12

Task	Result
<p>p. On CPG circuit breaker panel 2 (fig. 12-52), close <b>TADS DC</b> and <b>TADS AC</b> circuit breakers. On CPG <b>FIRE CONTROL</b> panel (fig. 12-45), set <b>SYSTEM TADS</b> switch to <b>TADS</b>. On CPG <b>AUX/ANTI-ICE</b> panel (fig. 12-51), set <b>TADS/PNVS</b> switch to <b>GND</b>. Place hand near top and sides of TADS shroud windows to check for warmer air temperature.</p>	<p>If air temperature does not get warmer (TADS shroud window heaters do not heat), go to paragraph 12-24.</p>

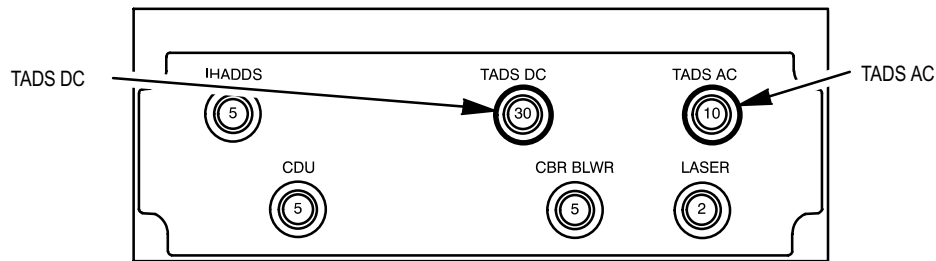

M71-022

Figure 12-52. CPG Circuit Breaker Panel 2

<p>q. On pilot center circuit breaker panel (fig. 12-43), close <b>COMM IFF</b> circuit breaker. On CPG <b>AUX/ANTI-ICE</b> panel, set <b>TADS/PNVS</b> switch to <b>ON</b>. Place hand near top and sides of TADS shroud windows to check air temperature.</p>	<p>If air temperature is not the same as in step p. (TADS shroud window heaters do not heat), go to paragraph 12-24.</p>
<p>r. On CPG <b>AUX/ANTI-ICE</b> panel, set <b>TADS/PNVS</b> switch to <b>OFF</b>. On CPG <b>FIRE CONTROL</b> panel, set <b>SYSTEM TADS</b> switch to <b>OFF</b>. On pilot center and aft circuit breaker panels, open <b>COMM IFF</b>, <b>ECS CANOPY ANTI-ICE CONTR</b>, <b>ECS CANOPY ANTI-ICE</b> circuit breakers. On CPG circuit breaker panel 2, open <b>TADS DC</b> and <b>TADS AC</b> circuit breakers. After 3 minutes, place hand near TADS shroud windows to check for cooler air temperature.</p>	<p>If air temperature does not get cooler, go to paragraph 12-24.</p>
<p>s. Remove squat switch fixture (TM 1-1520-238-23).</p>	

2. Perform CANOPY DEFOG and DE-ICE SYSTEM - POWER DOWN (para 12-11).
3. Disconnect maintenance headset (TM 1-1520-238-T-4).

END OF TASK

12-13. CANOPY DEFOG AND ANTI-ICE - WIRING INTERCONNECT DIAGRAM

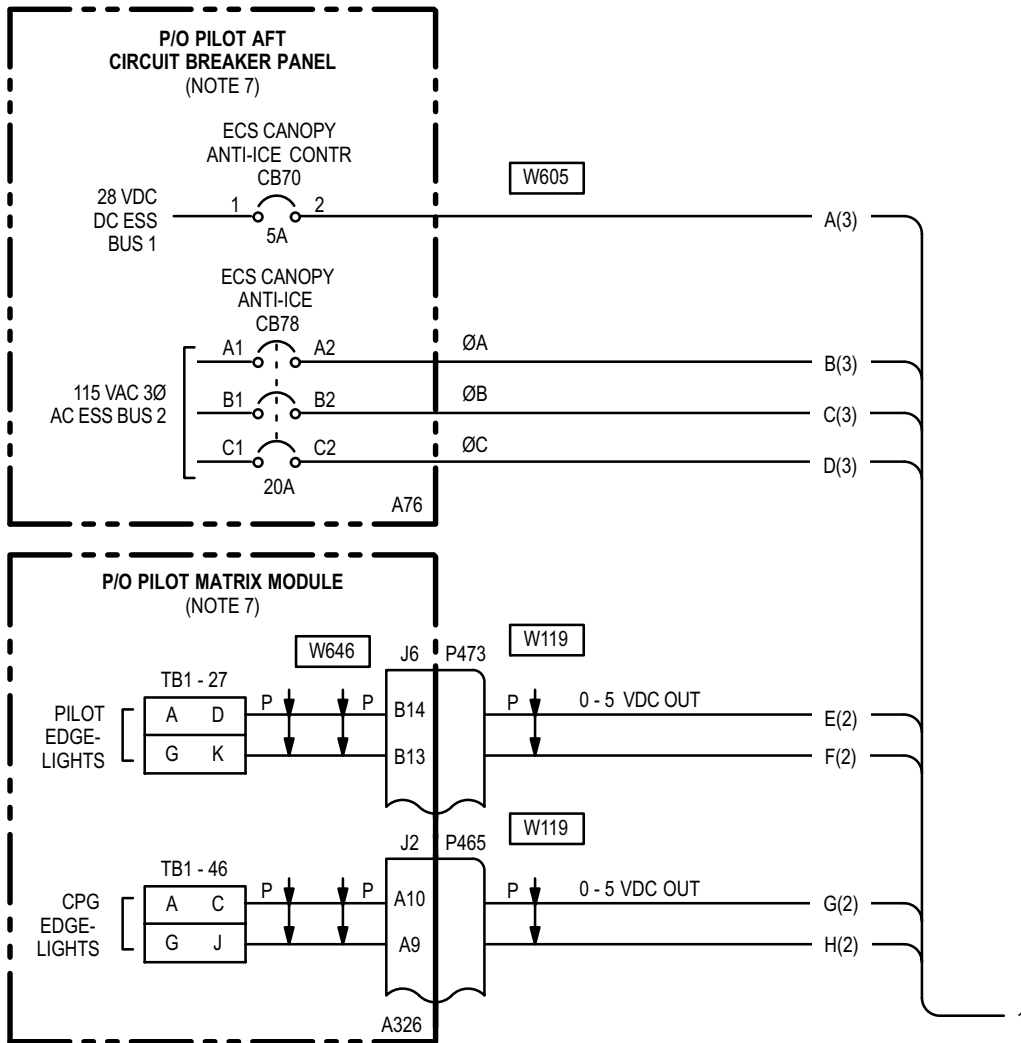



12-13. CANOPY DEFOG AND ANTI-ICE - WIRING INTERCONNECT DIAGRAM (cont)

12-13

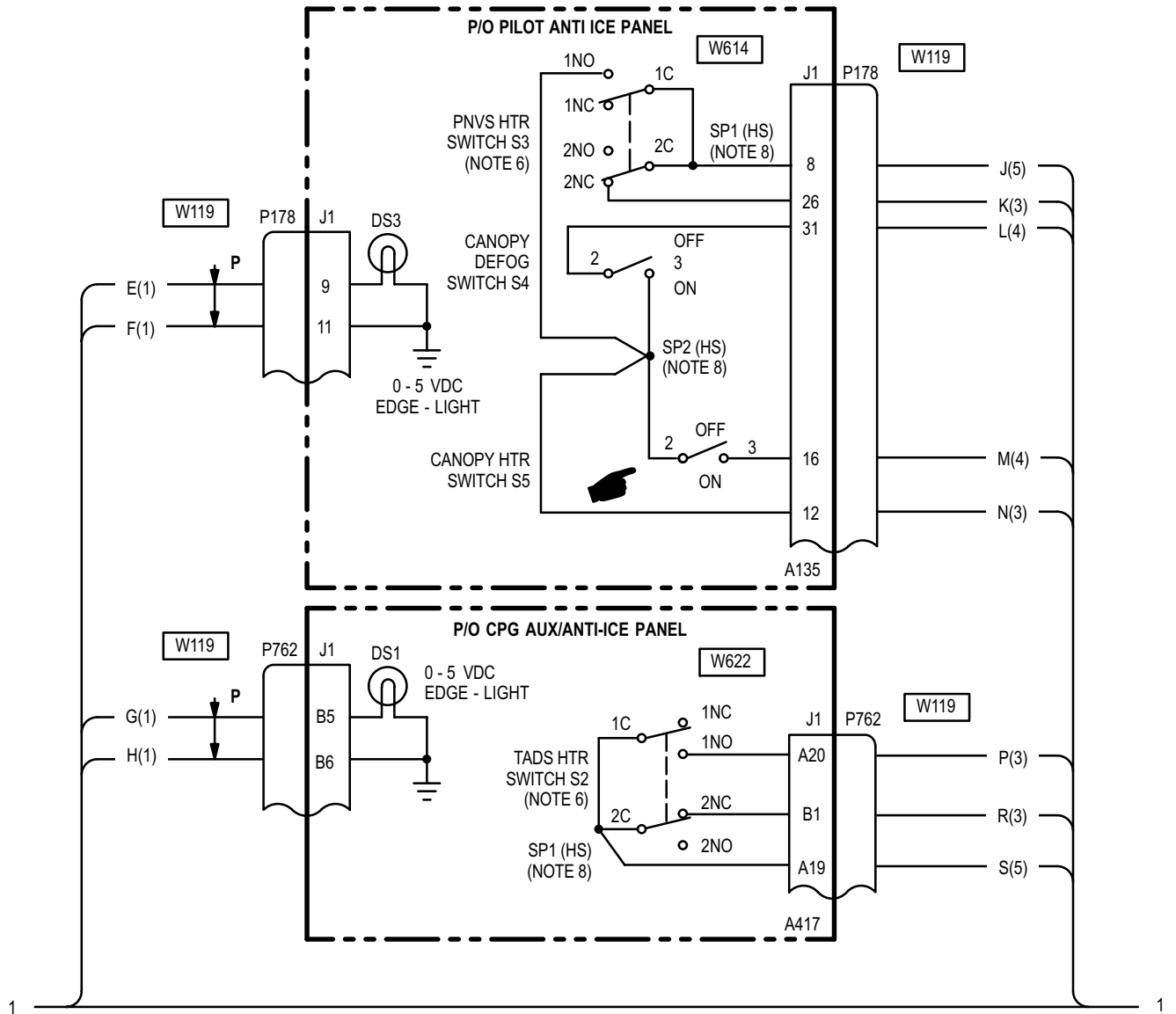

12-13. CANOPY DEFOG AND ANTI-ICE - WIRING INTERCONNECT DIAGRAM (cont)

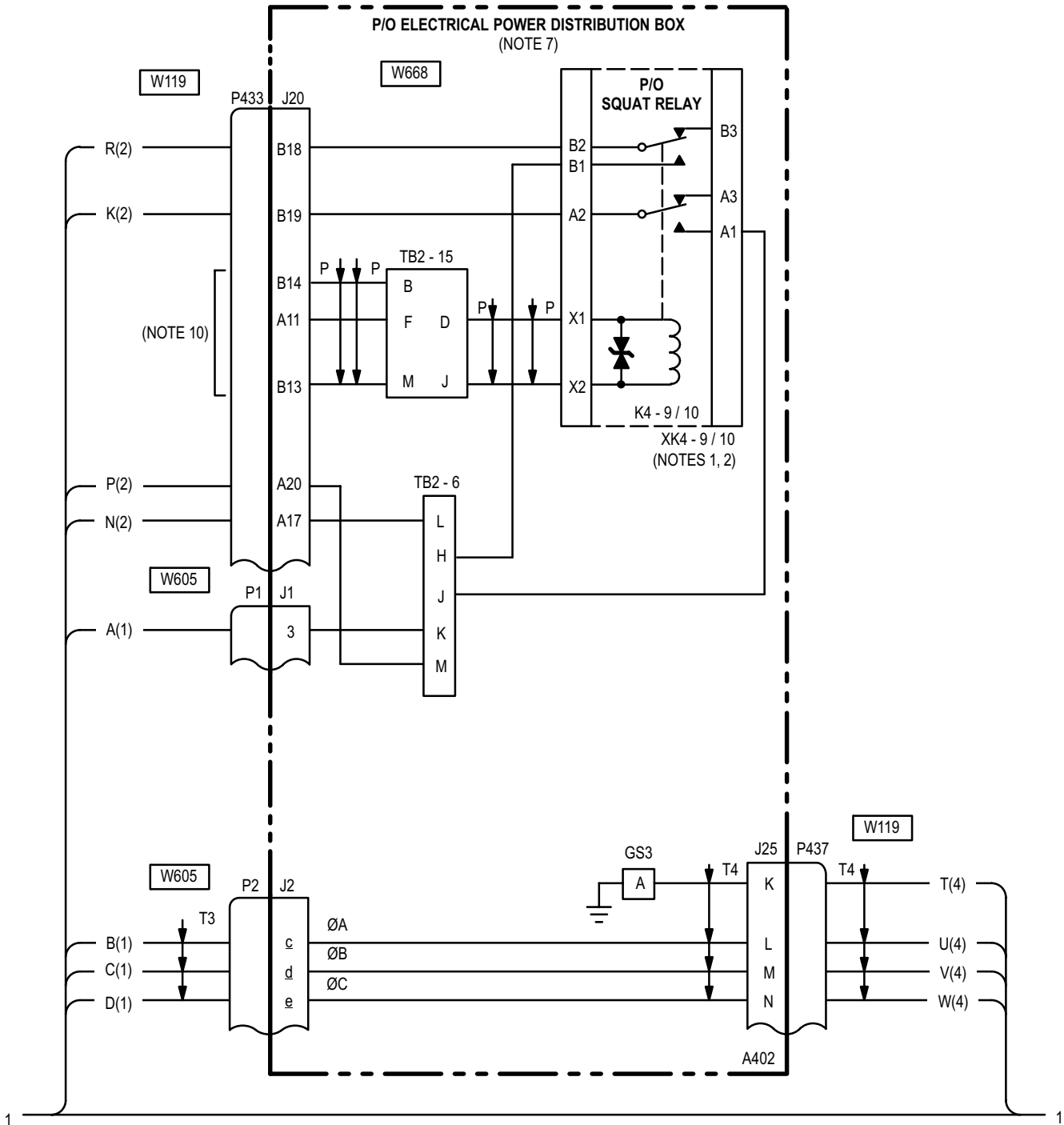

12-13. CANOPY DEFOG AND ANTI-ICE - WIRING INTERCONNECT DIAGRAM (cont)

12-13

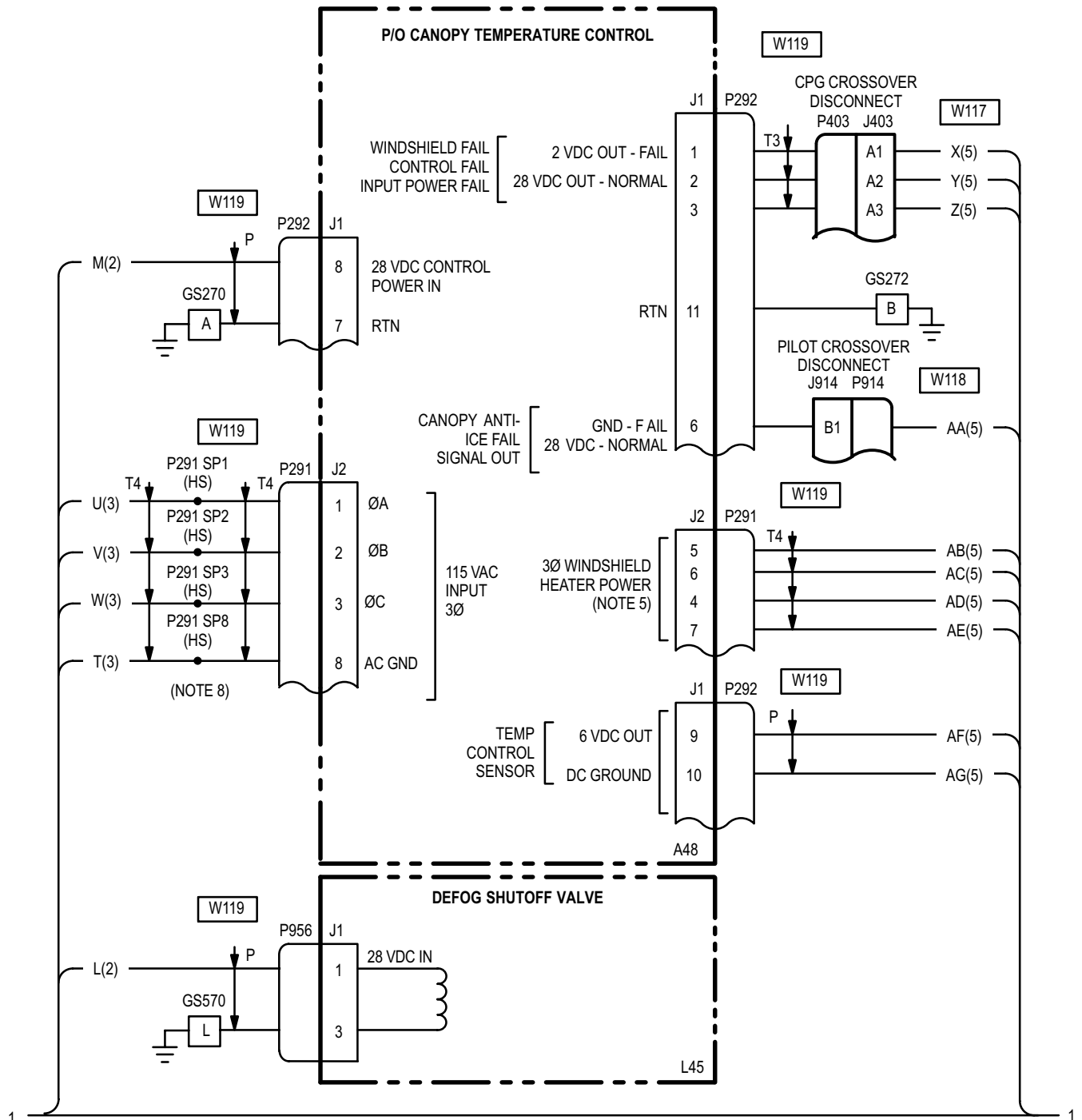

12-13. CANOPY DEFOG AND ANTI-ICE - WIRING INTERCONNECT DIAGRAM (cont)

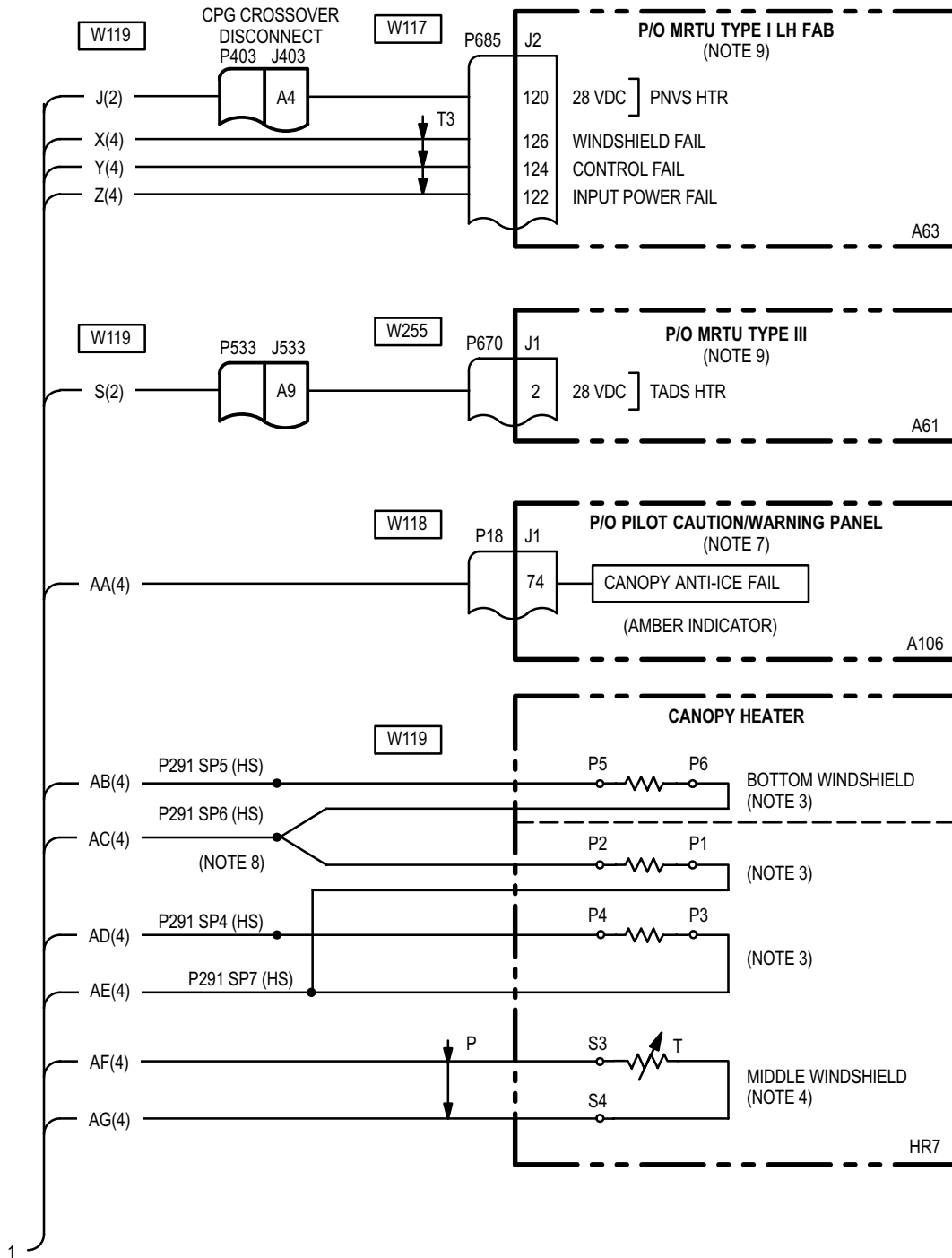

12-13. CANOPY DEFOG AND ANTI-ICE - WIRING INTERCONNECT DIAGRAM (cont)

12-13

NOTES:

HIGHWAY USE: THE ALPHA CHARACTER IDENTIFIES A SPECIFIC LINE, AND THE NUMBER IN PARENTHESIS IDENTIFIES THE SHEET NUMBER WHERE THE SIGNAL TERMINATES.

1. 28 VDC IN TO K4-9/10-X1 WITH IFF SYSTEM ENERGIZED.
2. RELAY ACTUATED BY SQUAT SWITCH S350.  
ON GROUND-CONTACTS B2 AND B3, AND A2 AND A3 CLOSED.  
AIRBORNE-CONTACTS B2 AND B1, AND A2 AND A1 CLOSED.
3. HEATING ELEMENT LINE-TO-LINE RESISTANCE:  
±15% NOMINAL  
21.3 OHMS MIN  
25.1 OHMS NOMINAL  
28.9 OHMS MAX
4. SENSING ELEMENT RESISTANCE.  
310 ± 3 OHMS AT 65°F (18.5°C)  
316 ± 3 OHMS AT 75°F (24.5°C)  
323 ± 3 OHMS AT 85°F (30.5°C)
5. 200 VAC OUT BETWEEN PINS 4-7, 5-6, AND 6-7.

6.

CONTACT	TADS/PNVS HTR SWITCH POSITIONS		
	GND	ON	OFF
1C-INC		X	X
1C-1NO	X		
2C-2NC	X	X	
2C-2NO			X

X = INDICATES CONTACTS CLOSED



7. ELECTRICAL SYSTEM (TM 1-1520-238-T-6).
8. HS DESIGNATES A HARD SPLICE WHICH CANNOT BE DISCONNECTED.  
M DESIGNATES A SOFT SPLICE WHICH MAY BE DISCONNECTED FOR A WIRING CHECK.
9. FIRE CONTROL SYSTEM - MULTIPLEX SUBSYSTEM (TM 9-1230-476-20-2).
10. AVIONICS CONFIGURATION - IFF (TM 11-1520-238-23-2).

**12-14. PILOT ANTI ICE PANEL EDGE-LIGHT - DOES NOT BRIGHTEN****12-14****Tools:**

<u>Nomenclature</u>	<u>Part Number</u>
Tool Kit, Electrical Repairer's	SC518099CLA06
Multimeter, Digital	AN/PSM-45

**Personnel Required:**

68X Armament/Electrical Systems Repairer  
One person to assist

**References:**

TM 1-1520-238-T-6  
TM 1-1520-238-23

**WARNING**

**Turn off power before detaching or attaching wires and connectors. High current 28 VDC or 115 VAC is present. Failure to do so could result in death or serious injury.**

1. On pilot **EXT LT /INTR LT** panel, rotate **L CSL** control between **OFF** and **BRT**. Check for 0 to 5 VDC between P178-9 and P178-11.

**Is voltage present?**

- |     |   |
|-----|---|
| YES | Replace pilot <b>ANTI ICE</b> panel (TM 1-1520-238-23). |
| NO  | Go to step 2.   |

2. Check for 0 to 5 VDC between (A326): J6-B14 and J6-B13.

**Is voltage present?**

- |     |  |
|-----|--|
| YES | Repair open wire between:<br>P473-B14 and P178-9,<br>P473-B13 and P178-11.<br>Go to paragraph 12-12. |
| NO  | Refer to TM 1-1520-238-T-6 to troubleshoot pilot edge-lights.  |

END OF TASK

**12-15. CPG AUX/ANTI-ICE PANEL EDGE-LIGHT - DOES NOT BRIGHTEN****12-15****Tools:**

<u>Nomenclature</u>	<u>Part Number</u>
Tool Kit, Electrical Repairer's	SC518099CLA06
Multimeter, Digital	AN/PSM-45

**Personnel Required:**

68X Armament/Electrical Systems Repairer  
One person to assist

**References:**

TM 1-1520-238-T-6  
TM 1-1520-238-23

**WARNING**

**Turn off power before detaching or attaching wires and connectors. High current 28 VDC or 115 VAC is present. Failure to do so could result in death or serious injury.**

1. On CPG **INTR LT** panel, rotate **L CSL** control between **OFF** and **BRT**. Check for 0 to 5 VDC between P762-B5 and P762-B6.  
**Is voltage present?**

YES	Replace CPG <b>AUX/ANTI-ICE</b> panel (TM 1-1520-238-23).
NO	Go to step 2.
  
2. Check for 0 to 5 VDC between (A326): J12-A10 and J12-A9.  
**Is voltage present?**

YES	Repair open wire between: P465-A10 and P762-B5, P465-A9 and P762-B6. Go to paragraph 12-12.
NO	Refer to TM 1-1520-238-T-6 to troubleshoot CPG edge-lights.

END OF TASK

**12-16. DEFOG SHUT OFF VALVE - DOES NOT OPERATE**

**12-16**

**Tools:**

<u>Nomenclature</u>	<u>Part Number</u>
Tool Kit, Electrical Repairer's	SC518099CLA06
Multimeter, Digital	AN/PSM-45

**Personnel Required:**

68X Armament/Electrical Systems Repairer  
One person to assist

**References:**

TM 1-1520-238-T-6  
TM 1-1520-238-23



**Turn off power before detaching or attaching wires and connectors. High current 28 VDC or 115 VAC is present. Failure to do so could result in death or serious injury.**

1. Check for 28 VDC at P178-12.  
**Is voltage present?**

YES	Go to step 3.
NO	Go to step 2.

2. Check for 28 VDC at P1-3.  
**Is voltage present?**

YES	Repair open wire between: P178-12 and P433-A17. (A402): J20-A17 and TB2-6-L, J1-3 and TB2-6-K. Go to paragraph 12-12.
NO	Refer to TM 1-1520-238-T-6 to troubleshoot circuit protection system (dc essential bus 1 - pilot station).

3. On pilot **ANTI ICE** panel, set **CANOPY DEFOG** switch to **ON** and check for 28 VDC between P956-1 and P956-3.  
**Is voltage present?**

YES	Replace defog shutoff valve (TM 1-1520-238-23).
NO	Go to step 4.

4. Check for open between: P956-1 and P178-31, P956-3 and ground.  
**Does open exist?**

YES	Repair open wire. Go to paragraph 12-12.
NO	Replace pilot <b>ANTI ICE</b> panel (TM 1-1520-238-23).

END OF TASK



**12-17. ECS CANOPY ANTI-ICE CIRCUIT BREAKER (CB78) - DOES NOT STAY CLOSED**

**12-17**

**Tools:**

<u>Nomenclature</u>	<u>Part Number</u>
Tool Kit, Electrical Repairer's	SC518099CLA06
Multimeter, Digital	AN/PSM-45

**Personnel Required:**

68X Armament/Electrical Systems Repairer

**References:**

TM 1-1520-238-T-6  
 TM 1-1520-238-23

- Detach P437. Check for short between:  
 P291-1 and ground,  
 P291-2 and ground,  
 P291-3 and ground.

**Does short exist?**

- |     |  |
|-----|--|
| YES | Repair shorted wire between:<br>P437-L and P291-1,<br>P437-M and P291-2,<br>P437-N and P291-3.<br>Go to paragraph 12-12. |
| NO  | Repair shorted wire between (A402):<br>J2-c and J25-L,<br>J2-d and J25-M,<br>J2-e and J25-N.<br>Go to paragraph 12-12.   |



**Turn off power before detaching or attaching wires and connectors. High current 28 VDC or 115 VAC is present. Failure to do so could result in death or serious injury.**

- Open **ECS CANOPY ANTI ICE** circuit breaker (CB78). Check for short between:  
 P2-c and ground,  
 P2-d and ground,  
 P2-e and ground.

**Does short exist?**

- |     |  |
|-----|--|
| YES | Refer to TM 1-1520-238-T-6 to troubleshoot circuit protection system (ac essential bus 2 - pilot station). |
| NO  | Go to step 2.  |

- Check for short between:  
 P291-8 and P291-1,  
 P291-8 and P291-2,  
 P291-8 and P291-3.

**Does short exist?**

- |     |  |
|-----|--|
| YES | Go to step 3.  |
| NO  | Replace canopy temperature control (TM 1-1520-238-23). |

END OF TASK

**12-18. ECS CANOPY ANTI-ICE CONTR CIRCUIT BREAKER (CB70) - DOES NOT STAY CLOSED** **12-18**

**Tools:**

<u>Nomenclature</u>	<u>Part Number</u>
Tool Kit, Electrical Repairer's	SC518099CLA06
Multimeter, Digital	AN/PSM-45

**Personnel Required:**

68X Armament/Electrical Systems Repairer  
One person to assist

**References:**

TM 1-1520-238-T-6  
TM 1-1520-238-23



**Turn off power before detaching or attaching wires and connectors. High current 28 VDC or 115 VAC is present. Failure to do so could result in death or serious injury.**

1. Open **ECS CANOPY ANTI ICE CONTR** circuit breaker (CB70). Check for short between P1-3 and ground.

**Does short exist?**

YES	Refer to TM 1-1520-238-T-6 to troubleshoot circuit protection system (ac essential bus 2 - pilot station).
NO	Go to step 2.

2. Detach P433. Check for short between (A402)J1-3 and ground.

**Does short exist?**

YES	Repair shorted wire between (A402): J1-3 and TB2-6-K, J20-A17 and TB2-6-L, J20-A20 and TB2-6-M. Go to paragraph 12-12.
NO	Go to step 3.

3. Check for short between P433-A20 and ground.

**Does short exist?**

YES	Go to step 6.
NO	Go to step 4.

4. On pilot **ANTI ICE** panel, set **CANOPY HTR** switch to **ON**. Detach P292. Check for short between P433-A17 and ground.

**Does short exist?**

YES	Go to step 5.
NO	Replace canopy temperature control (TM 55-1520-238-23).

5. Check for short between:

P178-12 and ground,  
P178-16 and ground.

**Does short exist?**

YES	Repair shorted wire between: P178-12 and P433-A17, P178-16 and P292-8. Go to paragraph 12-12.
NO	Replace pilot <b>ANTI ICE</b> panel (TM 1-1520-238-23).

6. Detach P762. Check for short between P433-A20 and ground.

**Does short exist?**

YES	Repair shorted wire between P433-A20 and P762-A20. Go to paragraph 12-12.
NO	Replace CPG <b>AUX/ANTI-ICE</b> panel (TM 1-1520-238-23).

END OF TASK

12-19. CANOPY WINDSHIELD HEATERS - DO NOT HEAT

12-19

**Tools:**

<u>Nomenclature</u>	<u>Part Number</u>
Tool Kit, Electrical Repairer's	SC518099CLA06
Multimeter, Digital	AN/PSM-45

**Personnel Required:**

68X Armament/Electrical Systems Repairer  
One person to assist

**References:**

TM 1-1520-238-T-6  
TM 1-1520-238-23



**Turn off power before detaching or attaching wires and connectors. High current 28 VDC or 115 VAC is present. Failure to do so could result in death or serious injury.**

1. Check for 115 VAC between:  
P291-8 and P291-1,  
P291-8 and P291-2,  
P291-8 and P291-3.  
**Is voltage present?**

YES Go to step 3.  
NO Go to step 2.

2. Check for 115 VAC at:  
P2-c,  
P2-d,  
P2-e.

**Is voltage present?**

YES Repair open wire between:  
P291-1 and P437-L,  
P291-2 and P437-M,  
P291-3 and P437-N,  
P291-8 and P437-K,  
(A402):  
J25-L and J2-c,  
J25-M and J2-d,  
J25-N and J2-e,  
J25-K and GS3-A,  
Go to paragraph 12-12.

NO Refer to TM 1-1520-238-T-6 to troubleshoot circuit protection system (ac essential bus 2 - pilot station).

3. Check for 28 VDC at P178-12.  
**Is voltage present?**

YES Go to step 5.  
NO Go to step 4.

4. Check for 28 VDC at P1-3.  
**Is voltage present?**

YES Repair open wire between:  
P178-12 and P433-A17.  
(A402):  
J20-A17 and TB2-6-L,  
J1-3 and TB2-6-K.  
Go to paragraph 12-12.

NO Refer to TM 1-1520-238-T-6 to troubleshoot circuit protection system (dc essential bus 1 - pilot station).

5. On pilot **ANTI ICE** panel, set **CANOPY HTR** switch to **ON**. Check for 28 VDC at P292-8.

**Is voltage present?**

YES Go to step 7.  
NO Go to step 6.

**12-19. CANOPY WINDSHIELD HEATERS - DO NOT HEAT (cont)**

**12-19**

6. Check for open between P292-8 and P178-16, P292-7 and GS270-A.

**Does open exist?**

- YES Repair open wire. Go to paragraph 12-12.
- NO Replace pilot **ANTI ICE** panel (TM 1-1520-238-23).

7. Check canopy heater element resistance between HR7-P5 and HR7-P6.

**Is 25 ±4 ohms resistance present?**

- YES Go to step 8.
- NO Replace CPG windshield forward canopy (TM 1-1520-238-23).

8. Check canopy heater element resistance between (HR7): P1 and P2, P4 and P3.

**Is 25 ±4 ohms resistance present?**

- YES Go to step 9.
- NO Replace pilot windshield (upper canopy) (TM 1-1520-238-23).

9. Check canopy heater sensing element resistance between (HR7)S3 and (HR7)S4.

**Is 316 ±7 ohms resistance present?**

- YES Go to step 10.
- NO Replace pilot windshield (upper canopy) (TM 1-1520-238-23).

10. Check for open between:

P291-5 and (HR7)P5,  
P291-6 and (HR7)P6,  
P291-6 and (HR7)P2,  
P291-4 and (HR7)P4,  
P291-7 and (HR7)P1,  
P291-7 and (HR7)P3,  
P292-9 and (HR7)S3,  
P292-10 and S4.

**Does open exist?**

- YES Repair open wire. Go to paragraph 12-12.
- NO Replace canopy temperature control (TM 1-1520-238-23).

END OF TASK

**12-20. CANOPY TEMP CONTROLLER NO-GO CPG COMPARTMENT - APPEARS ON HOD**

**12-20**

**Tools:**

<u>Nomenclature</u>	<u>Part Number</u>
Tool Kit, Electrical Repairer's	SC518099CLA06
Multimeter, Digital	AN/PSM-45

**Personnel Required:**

68X Armament/Electrical Systems Repairer  
One person to assist

**References:**

TM 1-1520-238-T-6  
TM 1-1520-238-23

**WARNING**

**Turn off power before detaching or attaching wires and connectors. High current 28 VDC or 115 VAC is present. Failure to do so could result in death or serious injury.**

1. Check for 28 VDC between P292-8 and P292-7.  
**Is voltage present?**

YES      Go to step 6.  
NO        Go to step 2.

2. Check for 28 VDC at P1-3.  
**Is voltage present?**

YES      Go to step 3.  
NO        Refer to TM 1-1520-238-T-6 to troubleshoot circuit protection system (dc essential bus 1 - pilot station).

3. Check for open between (A402)J1-3 and P178-12.

**Does open exist?**

YES      Go to step 5.  
NO        Go to step 4.

4. Set canopy **HTR** switch to **ON**. Check for open between (A135):  
J1-12 and J1-16.

**Does open exist?**

YES      Replace pilot **ANTI ICE** panel (TM 1-1520-238-23).  
NO        Repair open wire between: P292-8 and P178-16, P292-7 and ground.  
Go to paragraph 12-12.

5. Check for open between P178-12 and P433-A17.

**Does open exist?**

YES      Repair open wire.  
Go to paragraph 12-12.  
NO        Repair open wire between (A402):  
J1-3 and TB2-6-K,  
J20-A17 and TB2-6-L.  
Go to paragraph 12-12.

6. Check for open between: P292-2 and P685-124, P292-3 and P685-122, P292-11 and ground.

**Does open exist?**

YES      Repair open wire.  
Go to paragraph 12-12.  
NO        Replace canopy temperature control (TM 1-1520-238-23).

END OF TASK

**12-21. CANOPY TEMP SENSOR NO-GO CPG FR WINDSHIELD - APPEARS ON HOD**

**Tools:**

<u>Nomenclature</u>	<u>Part Number</u>
Tool Kit, Electrical Repairer's	SC518099CLA06
Multimeter, Digital	AN/PSM-45

**Personnel Required:**

68X Armament/Electrical Systems Repairer  
One person to assist

**References:**

TM 1-1520-238-T-6  
TM 1-1520-238-23  
TM 9-1230-476-20-2



**Turn off power before detaching or attaching wires and connectors. High current 28 VDC or 115 VAC is present. Failure to do so could result in death or serious injury.**

1. Check for 115 VAC between:  
P291-8 and P291-1,  
P291-8 and P291-2,  
P291-8 and P291-3.

**Is voltage present?**

YES      Go to step 3.  
NO        Go to step 2.

2. Check for open between:  
P291-8 and GS3-A,  
P291-1 and (A402)J2-c,  
P291-2 and (A402)J2-d,  
P291-3 and (A402)J2-e.

**Does open exist?**

YES      Repair open wire.  
            Go to paragraph 12-12.  
  
NO        Refer to TM 1-1520-238-T-6 to  
            troubleshoot circuit protection  
            system (ac essential bus 2 -  
            pilot station).

3. Check canopy heater sensing element between (HR7): S3 and S4.

**Is 316 (±7) ohms resistance present?**

YES      Go to step 4.  
NO        Replace pilot windshield  
            (TM 1-1520-238-23).

4. Check resistance between (HR7): P5 and P6.

**Is heating element resistance 25 ±4 ohms?**

YES      Go to step 5.  
NO        Replace CPG windshield  
            (TM 1-1520-238-23).

5. Check resistance between (HR7):  
P1 and P2,  
P3 and P4.

**Is heating element resistance 25 ±4 ohms?**

YES      Go to step 6.  
NO        Replace pilot windshield  
            (TM 1-1520-238-23).

6. Check for open between:  
P291-4 and (HR7)P4,  
P291-6 and (HR7)P2,  
P291-6 and (HR7)P6,  
P291-5 and (HR7)P5,  
P291-7 and (HR7)P1,  
P291-7 and (HR7)P3,  
S3 and P292-9,  
S4 and P292-10,  
P292-11 and ground.

**Does open exist?**

YES      Repair open wire.  
            Go to paragraph 12-12.  
  
NO        Go to step 7.

7. Check for 28 VDC at:  
P685-122,  
P685-124,  
P685-126.

**Is voltage present?**

YES      Refer to TM 9-1230-476-20-2 to  
            troubleshoot multiplex system  
            MRTU type I.  
  
NO        Go to step 8.

---

**12-21. CANOPY TEMP SENSOR NO-GO CPG FR WINDSHIELD -  
APPEARS ON HOD (cont)**

---

12-21

8. Check for open between:

P685-122 and P292-3,

P685-124 and P292-2,

P685-126 and P292-1.

**Does open exist?**

- |     |   |
|-----|---|
| YES | Repair open wire.<br>Go to paragraph 12-12.               |
| NO  | Replace canopy temperature<br>control (TM 1-1520-238-23). |

END OF TASK

---

**12-22. CANOPY ANTI ICE FAIL INDICATOR - DOES NOT LIGHT OR DOES NOT EXTINGUISH**

---

12-22

**Tools:**

<u>Nomenclature</u>	<u>Part Number</u>
Tool Kit, Electrical Repairer's	SC518099CLA06
Multimeter, Digital	AN/PSM-45

**Personnel Required:**

68X Armament/Electrical Systems Repairer  
One person to assist

**References:**

TM 1-1520-238-23

---

<b>WARNING</b>
----------------

**Turn off power before detaching or attaching wires and connectors. High current 28 VDC or 115 VAC is present. Failure to do so could result in death or serious injury.**

1. Check for 28 VDC at P292-6.

**Is voltage present?**

YES	Go to step 2.
NO	Go to step 3.

2. Check for open between:

P292-7 and ground,  
P292-11 and ground.

**Does open exist?**

YES	Repair open wire. Go to paragraph 12-12.
NO	Replace canopy temperature control (TM 1-1520-238-23).

3. Check for 28 VDC at (A106)J1-74.

**Is voltage present?**

YES	Repair open wire between P292-6 and P18-74. Go to paragraph 12-12.
NO	Replace pilot caution/warning panel (TM 1-1520-238-23).

END OF TASK



12-23. PNVS SHROUD WINDOW HEATER - DOES NOT HEAT

12-23

**Tools:**

<u>Nomenclature</u>	<u>Part Number</u>
Tool Kit, Electrical Repairer's	SC518099CLA06
Fixture, Squat Switch	7-3621MF002 (Make Item)
Multimeter, Digital	AN/PSM-45



**Do not touch PNVS shroud window. Touching shroud window makes cleaning necessary. Cleaning wears away protective coating on window.**

**Personnel Required:**

68X Armament/Electrical Systems Repairer  
One person to assist

**References:**

TM 1-1520-238-T-6  
TM 1-1520-238-23  
TM 9-1230-476-20-2

**Equipment Conditions:**

<u>Ref</u>	<u>Condition</u>
TM 1-1520-238-23	Squat switch fixture installed



- Turn off power before detaching or attaching wires and connectors. High current 28 VDC or 115 VAC is present. Failure to do so could result in death or serious injury.
- Do not touch fairings. Heaters in the fairings may cause serious burns. If injury occurs, seek medical aid.
- Do not touch PNVS shroud window. Electrical shock will result. If injury occurs, seek medical aid.

1. On pilot center circuit breaker panel, open **COMM IFF** circuit breaker. Check for 28 VDC at P178-12.  
**Is voltage present?**  

YES	Go to step 2.
NO	Go to step 7.
  
2. On pilot **ANTI ICE** panel, set **PNVS ANTI-ICE** switch to **GND**. Check for 28 VDC at P685-120.  
**Is voltage present?**  

YES	Go to step 3.
NO	Go to step 6.
  
3. Close **COMM IFF** circuit breaker. Set **PNVS ANTI-ICE** switch to **ON**. Check for 28 VDC at P178-26.  
**Is voltage present?**  

YES	Go to step 5.
NO	Go to step 4.
  
4. Check for open between: P433-B19 and P178-26. (A402): XK4-9/10-A2 and J20-B19, XK4-9/10-A1 and TB2-6-J, J1-3 and TB2-6-J.  
**Does open exist?**  

YES	Repair open wire. Go to paragraph 12-12.
NO	Replace relay (A402)K4-9/10 (TM 1-1520-238-23).

---

**12-23. PNVS SHROUD WINDOW HEATER - DOES NOT HEAT (cont)**

---

12-23

5. Check for 28 VDC at P685-120.

**Is voltage present?**

YES Refer to TM 9-1230-476-20-2 to troubleshoot multiplex system MRTU type I.

NO Replace pilot **ANTI ICE** panel (TM 1-1520-238-23).

6. Check for open between P685-120 and P178-8.

**Does open exist?**

YES Repair open wire.  
Go to paragraph 12-12.

NO Replace pilot **ANTI ICE** panel (TM 1-1520-238-23).

7. Check for 28 VDC at P1-3.

**Is voltage present?**

YES Repair open wire between P178-12 and P433-A17. (A402):  
J20-A17 and J1-3.  
Go to paragraph 12-12.

NO Refer to TM 1-1520-238-T-6 to troubleshoot circuit protection system (dc essential bus 1 - pilot station).

END OF TASK

12-24. TADS SHROUD WINDOW HEATERS - DO NOT HEAT

12-24

**Tools:**

<u>Nomenclature</u>	<u>Part Number</u>
Tool Kit, Electrical Repairer's	SC518099CLA06
Fixture, Squat Switch	7-3621MF002 (Make item)
Multimeter, Digital	AN/PSM-45



**Do not touch TADS shroud window. Touching shroud window makes cleaning necessary. Cleaning wears away protective coating on window.**

**Personnel Required:**

68X Armament/Electrical Systems Repairer  
One person to assist

**References:**

TM 1-1520-238-T-6  
TM 1-1520-238-23  
TM 9-1270-476-20-2

**Equipment Conditions:**

<u>Ref</u>	<u>Condition</u>
TM 1-1520-238-23	Squat switch fixture installed



- Turn off power before detaching or attaching wires and connectors. High current 28 VDC or 115 VAC is present. Failure to do so could result in death or serious injury.
- Do not touch TADS shroud window. Electrical shock will result. If injury occurs, seek medical aid.

1. Check for 28 VDC at P762-A20.  
**Is voltage present?**
  - YES Go to step 2.
  - NO Go to step 8.
  
2. On CPG **AUX/ANTI-ICE** panel, set **TADS/PNVS** switch to **GND**. Check for 28 VDC at P670-2.  
**Is voltage present?**
  - YES Go to step 3.
  - NO Go to step 7.
  
3. With **COMM IFF** circuit breaker closed, on CPG **AUX/ANTI-ICE** panel, set **TADS/PNVS** switch to **ON**. Check for 28 VDC at P670-2.  
**Is voltage present?**
  - YES Refer to TM 9-1270-476-20-2 to troubleshoot TADS shroud window heaters.
  - NO Go to step 4.
  
4. Check for 28 VDC at P762-B1.  
**Is voltage present?**
  - YES Replace CPG **AUX/ANTI-ICE** panel (TM 1-1520-238-23).
  - NO Go to step 5.
  
5. Check for open between P762-B1 and (A402)XK4-9/10-B2.  
**Does open exist?**
  - YES Repair open wire. Go to paragraph 12-12.
  - NO Go to step 6.

---

**12-24. TADS SHROUD WINDOW HEATERS - DO NOT HEAT (cont)**

---

**12-24**

6. Check for 28 VDC at (A402)XK4-9/10-B1.

**Is voltage present?**

- |     |   |
|-----|---|
| YES | Replace relay (A402)K4-9/10 (TM 1-1520-238-23).                                     |
| NO  | Repair open wire between (A402):<br>XK4-9/10-B1 and TB2-6-H. Go to paragraph 12-12. |

7. Check for open between P670-2 and P762-A19.

**Does open exist?**

- |     |   |
|-----|---|
| YES | Repair open wire.<br>Go to paragraph 12-12.               |
| NO  | Replace CPG <b>AUX/ANTI-ICE</b> panel (TM 1-1520-238-23). |

8. Check for 28 VDC at P1-3.

**Is voltage present?**

- |     |   |
|-----|---|
| YES | Repair open wire between:<br>P762-A20 and P433-A20.<br>(A402):<br>J20-A20 and TB2-6-M,<br>J1-3 and TB2-6-K.<br>Go to paragraph 12-12. |
| NO  | Refer to TM 1-1520-238-T-6 to troubleshoot circuit protection system (dc essential bus 1 - pilot station).                            |

END OF TASK

**12-25. ENGINE ANTI-ICE - MAINTENANCE OPERATIONAL CHECK**

**12-25**

**Tools:**

<u>Nomenclature</u>	<u>Part Number</u>
Tool Kit, Aircraft Mechanic's	SC518099CLA01

**Equipment Conditions:**

<u>Ref</u>	<u>Condition</u>
TM 1-1520-238-23	Helicopter safed Engine inspection completed APU operating - using battery power
TM 1-1520-238-T-4	Maintenance headset connected

**Personnel Required:**

67R Attack Helicopter Repairer  
One person to assist  
152FG Maintenance Test Pilot

**References:**

TM 1-1520-238-T-4  
TM 1-1520-238-23  
TM 1-1520-238-CL

**NOTE**

- Refer to pilot station (fig. 12-53) for cockpit configuration and equipment.
- If referenced out of one paragraph or volume and into another for additional troubleshooting, upon completion of the task, return to the maintenance operational check for the original paragraph or volume.

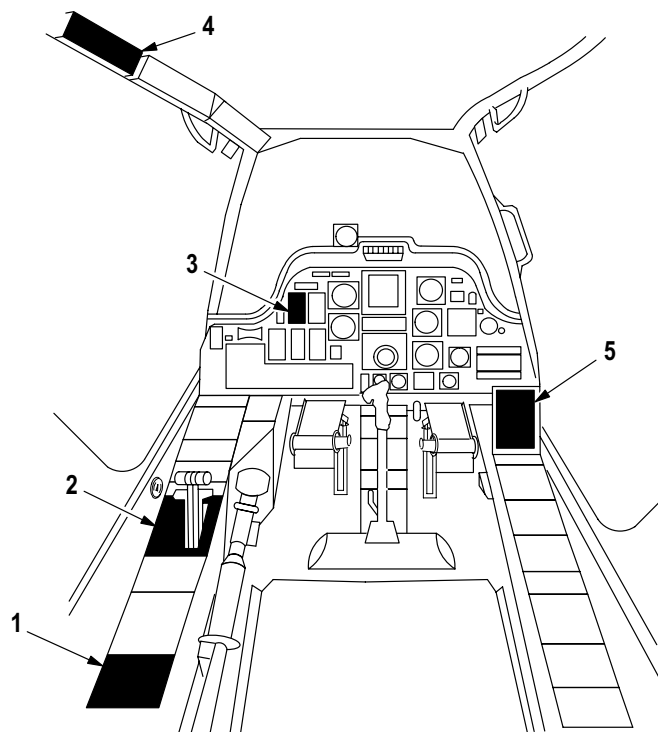

1. PILOT ANTI ICE PANEL
2. PILOT POWER QUADRANT
3. PILOT TURBINE GAS TEMPERATURE (TGT) INDICATOR
4. PILOT AFT CIRCUIT BREAKER PANEL
5. PILOT CAUTION/WARNING PANEL

M71-030

**Figure 12-53. Pilot Station**



To prevent failure or damage to components, do not perform engine anti-ice check when ambient air temperature is above 18° C (64° F).

1. Perform the maintenance operational check as follows:

Task	Result
<p>a. On pilot aft circuit breaker panel (fig. 12-54), check that the <b>ECS L NOSE GRBX HTR</b>, <b>ECS R NOSE GRBX HTR</b>, and <b>ECS ENG ANTI-ICE</b> circuit breakers are closed.</p>	<p>If <b>ECS L NOSE GRBX HTR</b> circuit breaker does not stay closed, go to paragraph 12-27.</p>
	<p>If <b>ECS R NOSE GRBX HTR</b> circuit breaker does not stay closed, go to paragraph 12-52.</p>
	<p>If <b>ECS ENG ANTI-ICE</b> circuit breaker does not stay closed, go to paragraph 12-28.</p>
<p>b. On pilot <b>ANTI ICE</b> panel (fig. 12-55), check that <b>ENG INLET ON/OFF</b> switch is set to <b>OFF</b>.</p>	<p>If <b>ENG 1 ANTI ICE</b> and <b>ENG 2 ANTI-ICE</b> indicators on pilot caution/warning panel (fig. 12-56) light, go to paragraph 12-29.</p>
	<p>If <b>ENG 1 ANTI ICE</b> indicator on pilot caution/warning panel lights, go to paragraph 12-30.</p>
	<p>If <b>ENG 2 ANTI ICE</b> indicator on pilot caution/warning panel lights, go to paragraph 12-31.</p>
	<p>If <b>ENG INLET ENG 1</b> and <b>ENG 2</b> advisory indicators on pilot <b>ANTI ICE</b> panel do not light, replace lamps (TM 1-1520-238-23). If lamps still do not light, go to paragraph 12-32.</p>
	<p>If <b>ENG INLET ENG 1</b> advisory indicator on pilot <b>ANTI ICE</b> panel does not light, replace lamp (TM 1-1520-238-23). If lamp still does not light, go to paragraph 12-33.</p>
	<p>If <b>ENG INLET ENG 2</b> advisory indicator on pilot <b>ANTI ICE</b> panel does not light, replace lamp (TM 1-1520-238-23). If lamp still does not light, go to paragraph 12-34.</p>

12-25. ENGINE ANTI-ICE - MAINTENANCE OPERATIONAL CHECK (cont)

12-25

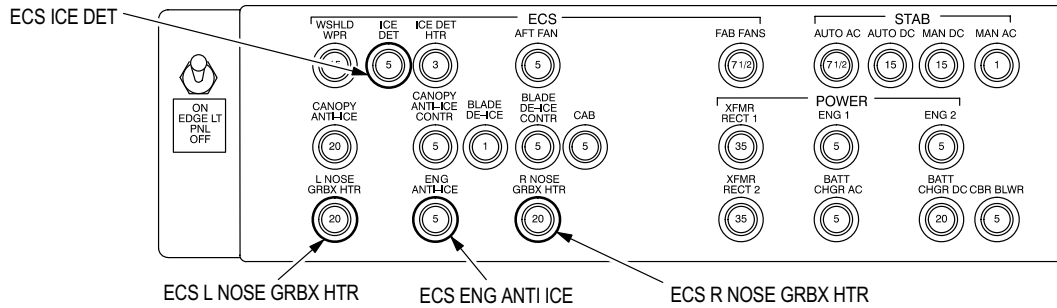

M71-031

Figure 12-54. Pilot Aft Circuit Breaker Panel

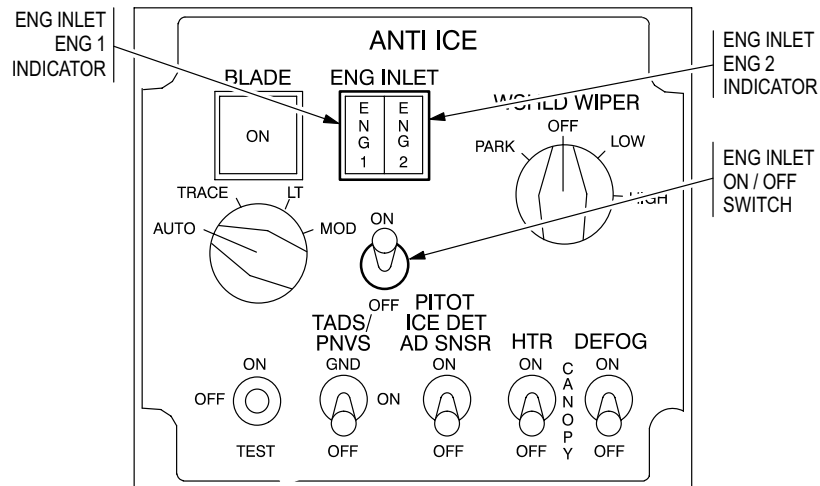

M71-032

Figure 12-55. Pilot ANTI ICE Panel

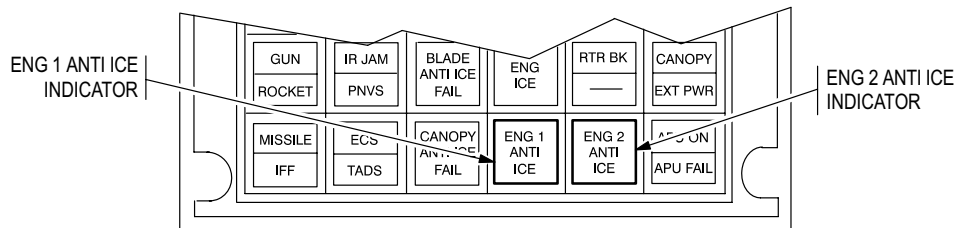

M71-033

Figure 12-56. Pilot Caution/Warning Panel

Task

Result

**WARNING**

Do not touch engine 1 or engine 2 nose gearbox or upper aft fairings when **ENG INLET ON/OFF** switch is set to **ON**. Heaters in these fairings can cause serious burns. If burns occur, seek medical aid.

**CAUTION**

To avoid failure or damage to components, do not activate **ENG INLET ON/OFF** switch any longer than necessary to accomplish steps.

- c. On pilot **ANTI ICE** panel (fig. 12-55), set **ENG INLET ON/OFF** switch to **ON**.

If **ECS ENG ANTI-ICE** circuit breaker does not stay closed, go to paragraph 12-37.

If **ECS L NOSE GRBX HTR** circuit breaker does not stay closed, go to paragraph 12-35.

If **ECS R NOSE GRBX HTR** circuit breaker does not stay closed, go to paragraph 12-53.

If **ENG 1 ANTI ICE** and **ENG 2 ANTI ICE** indicators on pilot caution/warning panel do not light, replace lamps (TM 1-1520-238-23). If lamps still do not light, go to paragraph 12-38.

If **ENG 1 ANTI ICE** indicator on pilot caution/warning panel does not light, replace lamp (TM 1-1520-238-23). If lamp still does not light, go to paragraph 12-39.

If **ENG 2 ANTI ICE** indicator on pilot caution/warning panel does not light, replace lamp (TM 1-1520-238-23). If lamp still does not light, go to paragraph 12-40.

If engine 1 NGB fairing does not get hot, go to paragraph 12-41.

If engine 1 upper aft fairing does not get hot, go to paragraph 12-50.

If engine 2 NGB fairing does not get hot, go to paragraph 12-42.

If engine 2 upper aft fairing does not get hot, go to paragraph 12-51.



12-25. ENGINE ANTI-ICE - MAINTENANCE OPERATIONAL CHECK (cont)

12-25

Task	Result
------	--------

**NOTE**

The following results will only occur during severe icing conditions:

- d. On pilot power quadrant (fig. 12-57), set **ENG START** switch **NO 1** or **NO 2** to **IGN OVRD** with **ENG INLET ON/OFF** switch on the pilot **ANTI ICE** panel (fig. 12-55) set to **ON**. Monitor the **ENG 1** and **ENG 2 ANTI ICE** indicators on the pilot caution/warning panel (fig. 12-56) (TM 1-1520-238-CL).
- e. Set **ENG INLET ON/OFF** switch to **OFF**.

If **ENG 1 ANTI ICE** and **ENG 2 ANTI ICE** indicators on pilot caution/warning panel remain lighted, go to paragraph 12-43.

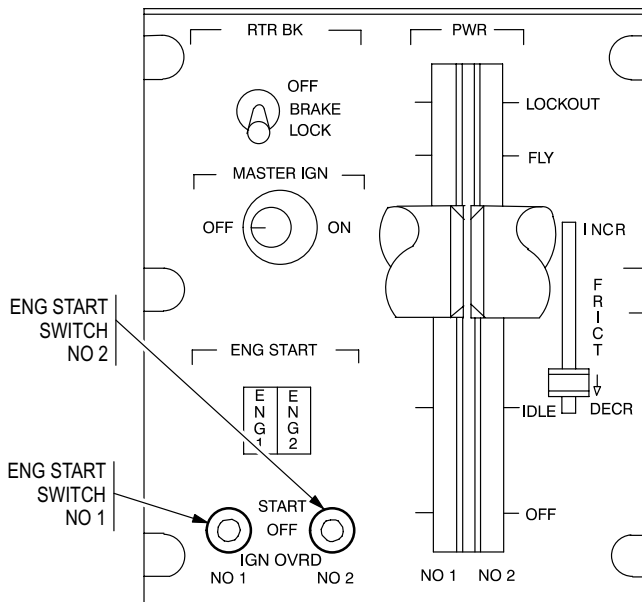

M71-034

**Figure 12-57. Pilot Power Quadrant**

- f. Start engines 1 and 2 (TM 1-1520-238-CL). Wait until engines 1 and 2 stabilize at idle.
- g. Increase **N<sub>G</sub> RPM%** on engine 1 to between 90% and 92% while engine 2 is at **IDLE**. Monitor engine 1 pilot **TGT** indicator (fig. 12-58).

If **ENG 1 ANTI ICE** indicator on pilot caution/warning panel lights, go to paragraph 12-44.

If **ENG 2 ANTI ICE** indicator on pilot caution/warning panel lights, go to paragraph 12-45.

If **ENG INLET ENG 1** indicator on pilot **ANTI ICE** panel remains lighted, go to paragraph 12-46.

Task	Result
------	--------

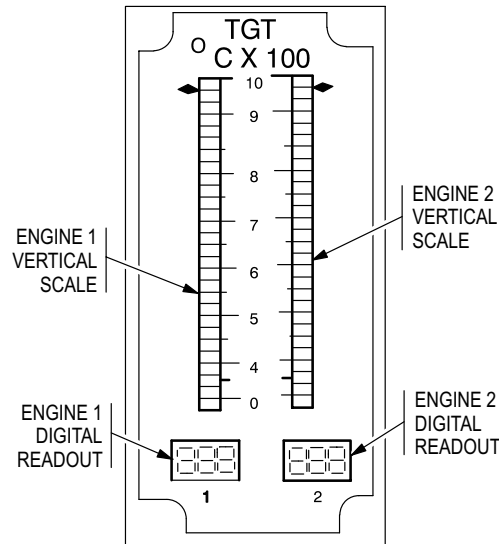

M71-035

**Figure 12-58. Pilot TGT Indicator**

- h. On pilot aft circuit breaker panel (fig. 12-54), open **ECS ENG ANTI-ICE** circuit breaker. Check for a 60° C increase in engine 1 TGT. Close **ECS ENG ANTI-ICE** circuit breaker. Check for an increase of at least 30° C in engine 1 TGT.

If engine 1 TGT increases 40° C, replace engine 1 anti-ice valve (TM 1-1520-238-23).

If engine 1 TGT increases 10° to 20° C replace engine 1 **ANTI-ICE/START BLEED VALVE** (TM 1-1520-238-23).

If engine 1 TGT does not increase at least 30° C, replace engine 1 **ANTI-ICE VALVE** (TM 1-1520-238-23).

Green advisory lights on **ANTI ICE** panel should be lighted.

- i. On pilot power quadrant (fig. 12-57), set engine **NO 1 PWR** lever to **IDLE**. Increase **N<sub>G</sub>** on engine 2 between 90 and 92% while engine 1 remains at **IDLE**. Monitor engine 2 pilot TGT indicator (fig. 12-58).

If **ENG INLET ENG 2** advisory indicator on pilot **ANTI ICE** panel (fig. 12-55) remains lighted, go to paragraph 12-47.

**12-25. ENGINE ANTI-ICE - MAINTENANCE OPERATIONAL CHECK (cont)****12-25**

Task	Result
<p>j. Open <b>ECS ENG ANTI-ICE</b> circuit breaker. Check for a 60° C increase in engine <b>2 TGT</b>. Close <b>ECS ENG ANTI-ICE</b> circuit breaker. Check for an increase of at least 30° C in engine <b>2 TGT</b>.</p>	<p>If engine <b>2 TGT</b> increases 40° C, replace engine 2 anti-ice valve (TM 1-1520-238-23).</p> <p>If engine <b>2 TGT</b> increases 10° to 20° C replace engine <b>2 ANTI-ICE/START BLEED VALVE</b> (TM 1-1520-238-23).</p> <p>If engine <b>2 TGT</b> does not increase at least 30° C, replace engine <b>2 ANTI-ICE VALVE</b> (TM 1-1520-238-23).</p> <p>Green advisory lights on <b>ANTI ICE</b> panel should be lighted.</p>

**NOTE**

**ENG ANTI ICE caution/warning indicators may light for several seconds when the system is turned on, until a thermal switch in each engine inlet bleed air line heats up.**

- |  |  |
|--|--|
| <p>k. On pilot <b>ANTI ICE</b> panel (fig. 12-55), set <b>ENG INLET ON/OFF</b> switch to <b>ON</b> and allow several seconds for inlet bleed air to heat the thermal switches.</p> | <p>If <b>ECS ENG ANTI-ICE</b> circuit breaker does not stay closed, go to paragraph 12-36.</p> <p>If <b>ENG 1 ANTI ICE</b> indicator on pilot caution/warning panel lights, go to paragraph 12-48.</p> <p>If <b>ENG 2 ANTI ICE</b> indicator on pilot caution/warning panel lights, go to paragraph 12-49.</p> |
|--|--|

**NOTE**

**ENG ANTI-ICE caution/warning indicators may light for several minutes when the system is turned off, until a thermal switch in each engine inlet bleed air line cools off.**

- l. On pilot **ANTI ICE** panel, set **ENG INLET ON/OFF** switch to **OFF**.

2. Shut down engines 1 and 2 (TM 1-1520-238-CL).
3. Shut down APU (TM 1-1520-238-23).
4. Disconnect maintenance headset (TM 1-1520-238-T-4).

END OF TASK

12-26. ENGINE ANTI-ICE - WIRING INTERCONNECT DIAGRAM

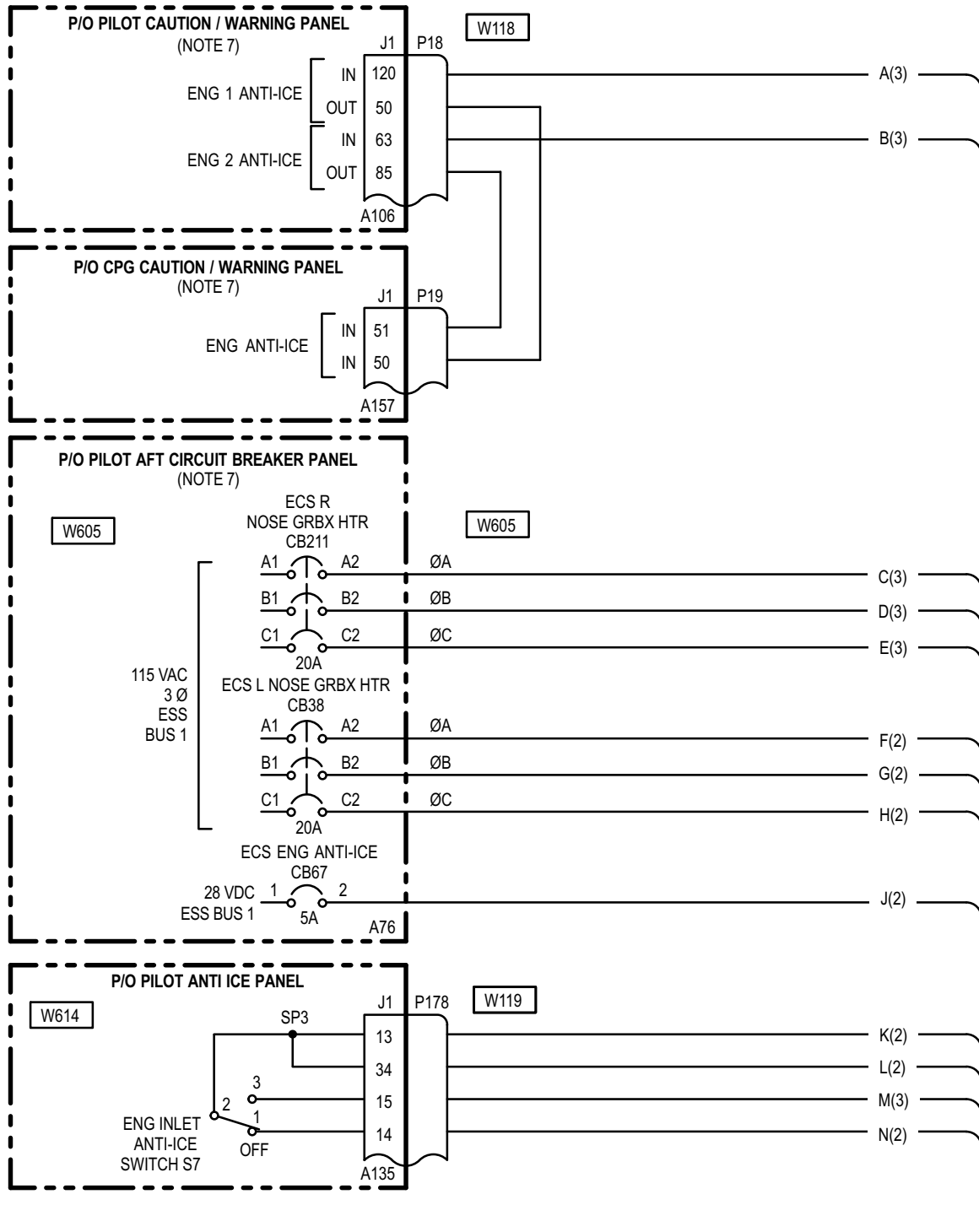

1

12-26. ENGINE ANTI-ICE - WIRING INTERCONNECT DIAGRAM (cont)

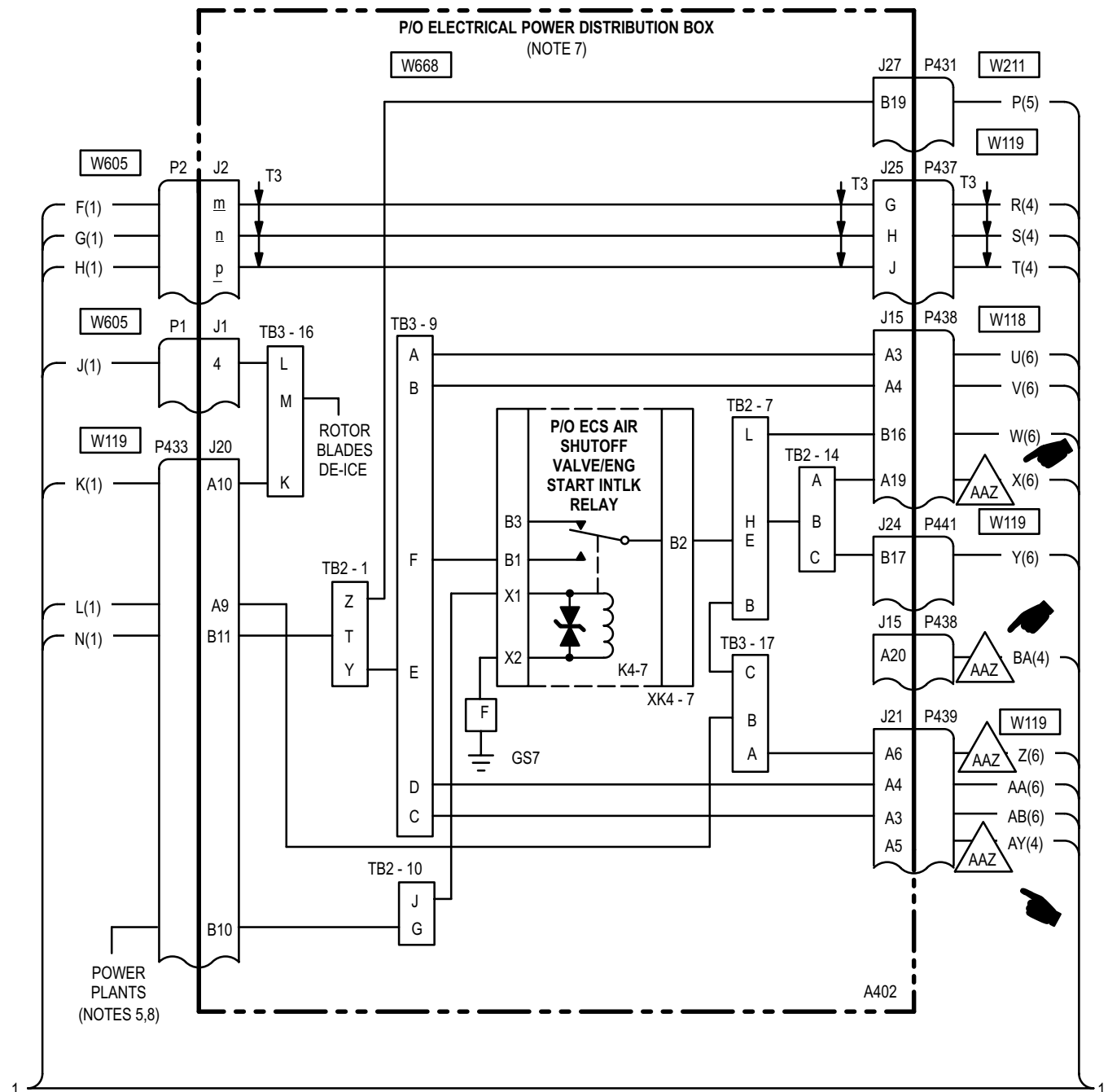

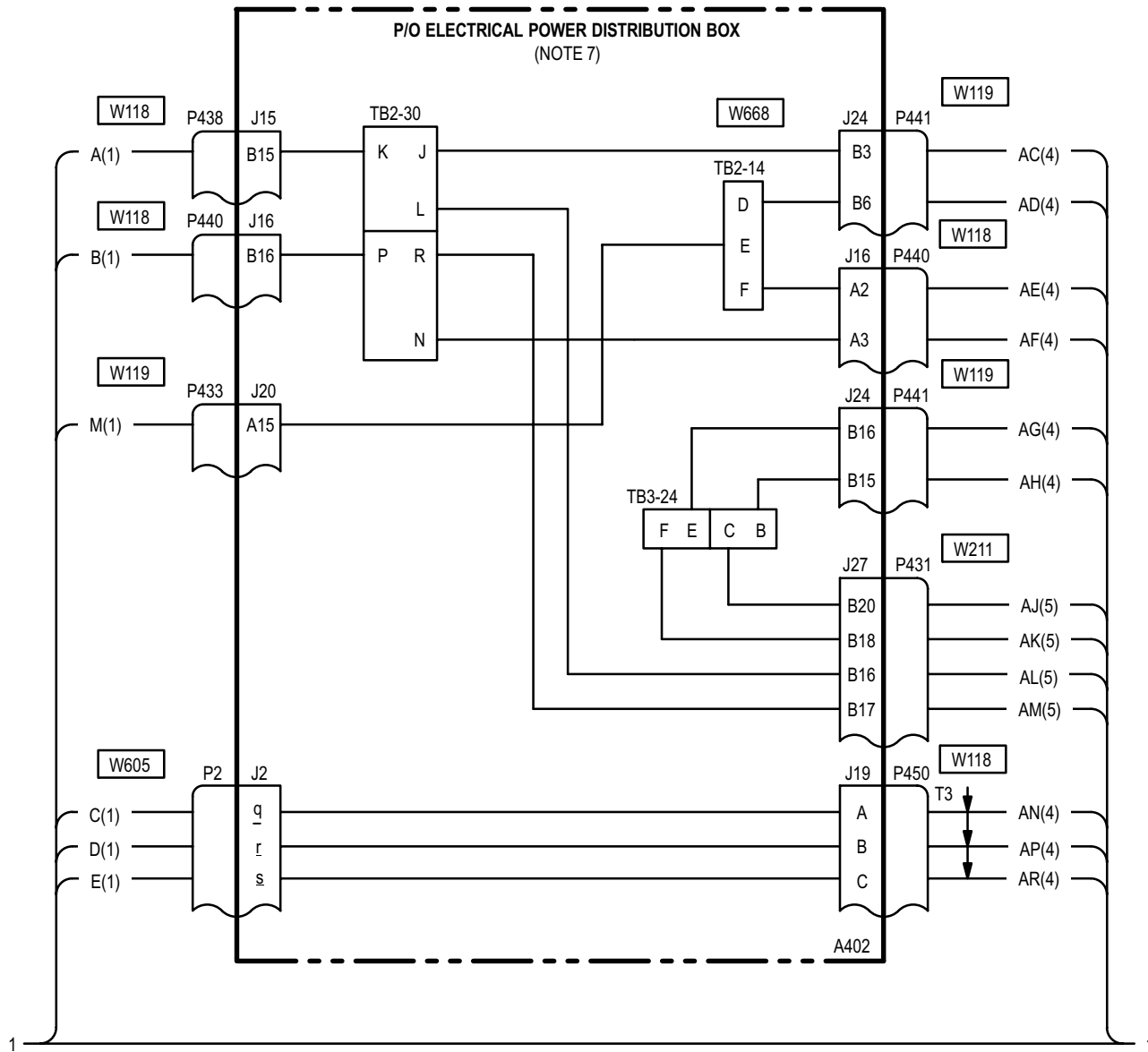

12-26. ENGINE ANTI-ICE - WIRING INTERCONNECT DIAGRAM (cont)

12-26

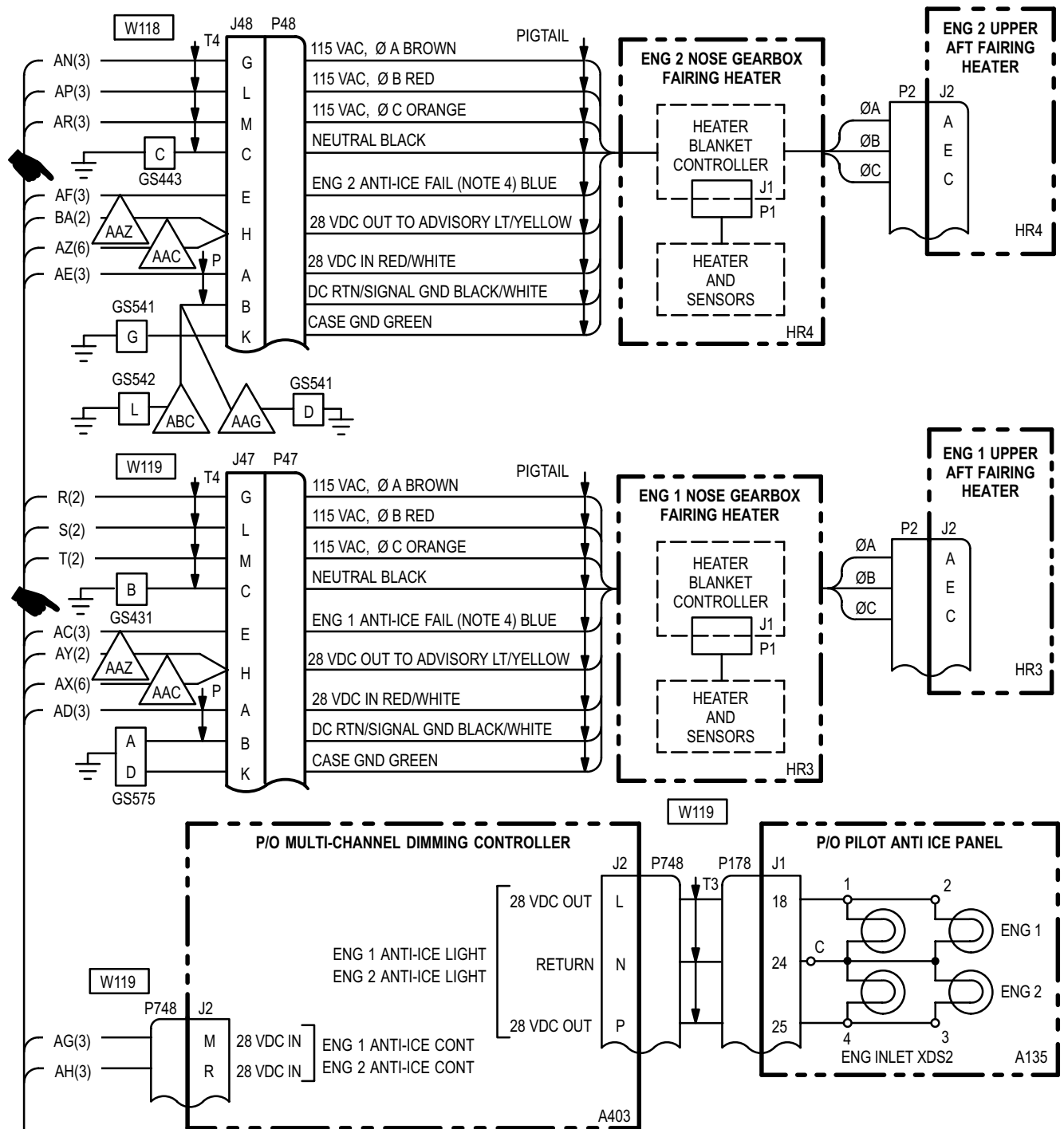

1

1

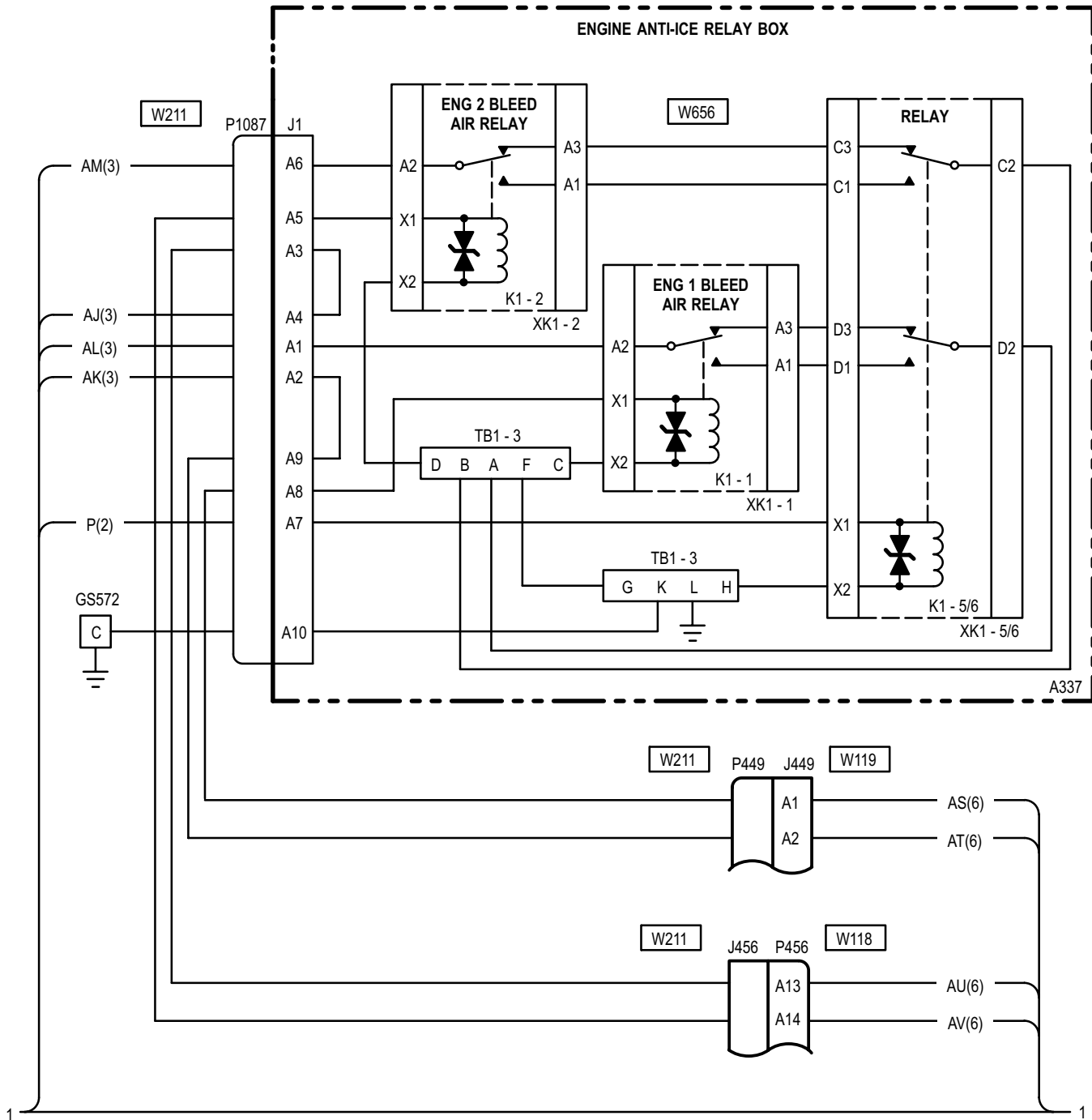



12-26. ENGINE ANTI-ICE - WIRING INTERCONNECT DIAGRAM (cont)

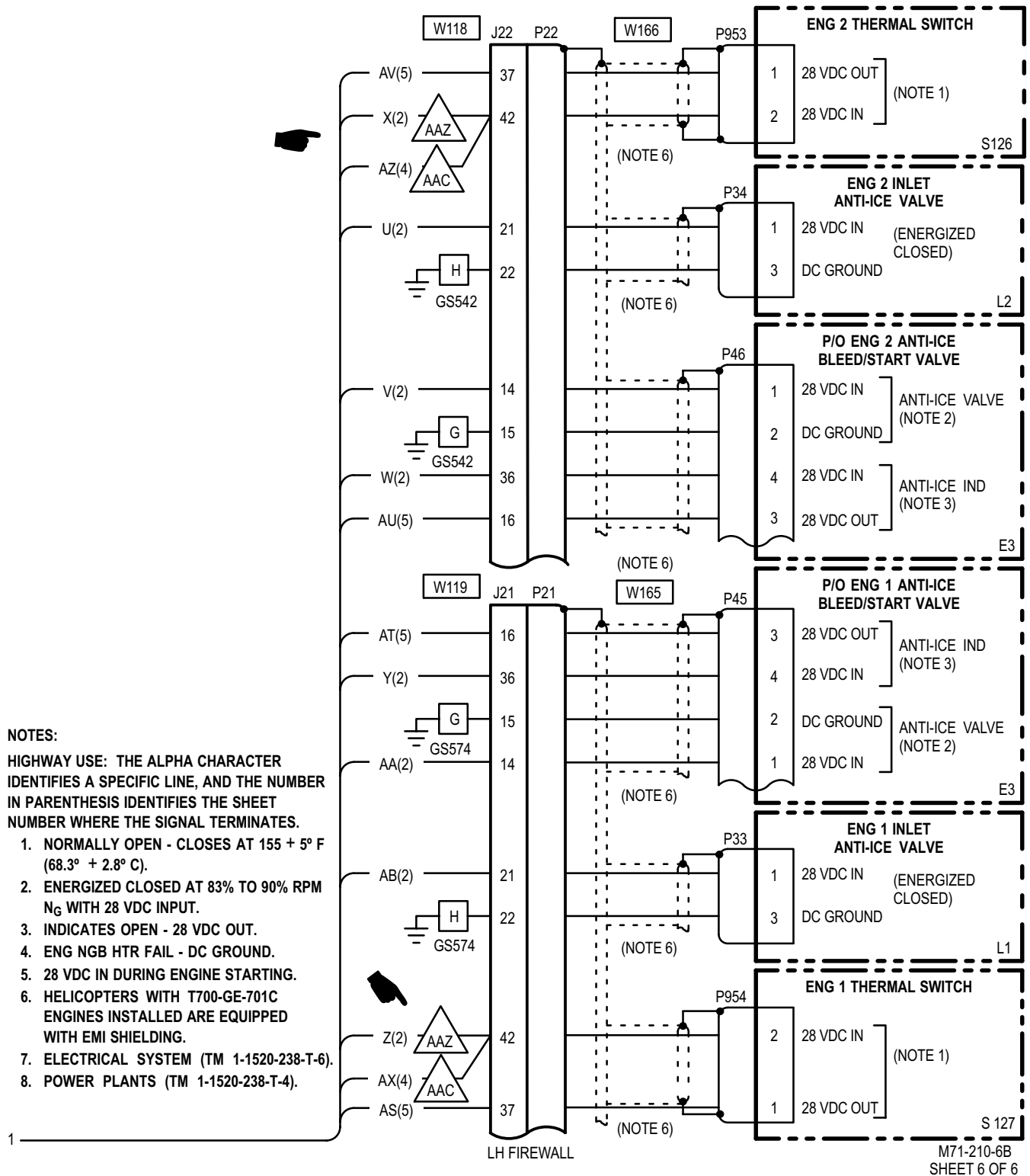

---

**12-27. ECS L NOSE GRBX HTR CIRCUIT BREAKER (CB38) - DOES NOT STAY CLOSED (ENG INLET ON/OFF SWITCH OFF)** **12-27**

---

**Tools:**

<u>Nomenclature</u>	<u>Part Number</u>
Tool Kit, Electrical Repairer's	SC518099CLA06
Multimeter, Digital	AN/PSM-45

**Personnel Required:**

68X Armament/Electrical Systems Repairer

**References:**

TM 1-1520-238-T-6  
 TM 1-1520-238-23

**Equipment Conditions:**

<u>Ref</u>	<u>Condition</u>
TM 1-1520-238-23	Access provisions - L200 panel removed

---

3. Check for short between:

P437-G and ground,  
 P437-H and ground,  
 P437-J and ground.

**Does short exist?**

- |     |  |
|-----|--|
| YES | Repair shorted wire between:<br>P437-G and J47-G,<br>P437-H and J47-L,<br>P437-J and J47-M.<br>Go to paragraph 12-25.  |
| NO  | Repair shorted wire between (A402):<br>J2-m and J25-G,<br>J2-n and J25-H,<br>J2-p and J25-J.<br>Go to paragraph 12-25. |



**Turn off power before detaching or attaching wires and connectors. High current 28 VDC or 115 VAC is present. Failure to do so could result in death or serious injury.**

1. Check for short between (A402):

J2-m and ground,  
 J2-n and ground,  
 J2-p and ground.

**Does short exist?**

- |     |  |
|-----|--|
| YES | Go to step 2.  |
| NO  | Refer to TM 1-1520-238-T-6 to troubleshoot circuit protection system (ac essential bus 1 - pilot station). |

2. Check for short between:

J47-G and ground,  
 J47-L and ground,  
 J47-M and ground.

**Does short exist?**

- |     |   |
|-----|---|
| YES | Go to step 3.                           |
| NO  | Replace NGB fairing (TM 1-1520-238-23). |

END OF TASK

**12-28. ECS ENG ANTI-ICE CIRCUIT BREAKER (CB67) - DOES NOT STAY CLOSED  
(ENG INLET ON/OFF SWITCH OFF)**

**12-28**

**Tools:**

<u>Nomenclature</u>	<u>Part Number</u>
Tool Kit, Electrical Repairer's	SC518099CLA06
Extractor, Relay	CTJ-RO6
Multimeter, Digital	AN/PSM-45

**Personnel Required:**

68X Armament/Electrical Systems Repairer

**References:**

TM 1-1520-238-T-6  
TM 1-1520-238-23

**WARNING**

**Turn off power before detaching or attaching wires and connectors. High current 28 VDC or 115 VAC is present. Failure to do so could result in death or serious injury.**

1. Open **ECS ENG ANTI-ICE** circuit breaker (CB67). Check for short between P1-4 and ground.

**Does short exist?**

YES	Refer to TM 1-1520-238-T-6 to troubleshoot circuit protection system (dc essential bus 1 -pilot station).
NO	Go to step 2.

2. Detach P21, P22 and P431. Check for short between (A402)J1-4 and ground.

**Does short exist?**

YES	Go to step 3.
NO	Go to step 13.

3. Detach P438, P439 and P441. Check for short between (A402)J1-4 and ground.

**Does short exist?**

YES	Go to step 8.
NO	Go to step 4.

4. Check for 320 ±20 ohms between P431-B19 and ground.

**Is resistance present?**

YES	Go to step 5.
NO	Go to step 7.

5. Check for short between:

P438-A3 and ground,  
P438-A4 and ground,  
P438-B16 and ground,  
P438-A19 and ground.

**Does short exist?**

YES	Repair shorted wire between: P438-A3 and J22-21, P438-A4 and J22-14, P438-A19 and J22-42, P438-B16 and J22-36. Go to paragraph 12-25.
NO	Go to step 6.

6. Detach P21. Check for short between:

P439-A3 and ground,  
P439-A4 and ground,  
P439-A6 and ground.

**Does short exist?**

YES	Repair shorted wire between: P439-A3 and J21-21, P439-A4 and J21-14, P439-A6 and J21-42. Go to paragraph 12-25.
NO	Repair shorted wire between P441-B17 and J21-36. Go to paragraph 12-25.

**12-28. ECS ENG ANTI-ICE CIRCUIT BREAKER (CB67) - DOES NOT STAY CLOSED  
(ENG INLET ON/OFF SWITCH OFF) (cont)**

7. With relay (A337)K1-5/6 removed, check for short between P431-B19 and ground.  
**Does short exist?**
- |     |  |
|-----|--|
| YES | Repair shorted wire between: P431-B19 and P1087-A7. (A337): J1-A7 and XK1-5/6-X1. Go to paragraph 12-25. |
| NO  | Replace relay (A337)K1-5/6 (TM 1-1520-238-23).   |
8. Check for short between (A135): J1-13 and chassis ground, J1-14 and chassis ground.  
**Does short exist?**
- |     |   |
|-----|---|
| YES | Replace pilot <b>ANTI ICE</b> panel (TM 1-1520-238-23). |
| NO  | Go to step 9.   |
9. Detach P178. Check for short between (A402)J1-4 and ground.  
**Does short exist?**
- |     |  |
|-----|--|
| YES | Repair shorted wire between: P178-13 and P433-A10. (A402): TB3-16-L and J1-4, TB3-16-M and XK5-10-A2, TB3-16-K and J20-A10. Go to paragraph 12-25. |
| NO  | Go to step 10.   |
10. Detach P433. Check for short between: P178-14 and ground, P178-34 and ground.  
**Does short exist?**
- |     |  |
|-----|--|
| YES | Repair shorted wire between: P178-14 and P433-B11, P178-34 and P433-A9. Go to paragraph 12-25. |
| NO  | Go to step 11.   |
11. With relay (A402)K4-7 removed, check for short between (A402): K4-7-B1 and relay case, K4-7-B2 and relay case.  
**Does short exist?**
- |     |  |
|-----|--|
| YES | Replace relay (A402)K4-7 (TM 1-1520-238-23). |
| NO  | Go to step 12.                               |
12. Check for short between (A402)J20-B11 and ground.  
**Does short exist?**
- |     |   |
|-----|---|
| YES | Repair shorted wire between (A402): TB2-1-T and J20-B11, TB2-1-Z and J27-B19, TB2-1-Y and TB3-9-E, TB3-9-A and J15-A3, TB3-9-B and J15-A4, TB3-9-C and J21-A3, TB3-9-D and J21-A4, TB3-9-F and XK4-7-B1. Go to paragraph 12-25.         |
| NO  | Repair shorted wire between (A402): TB3-17-A and J21-A6, TB3-17-B and J20-A9, TB3-17-C and TB2-7-B, TB2-14-B and TB2-7-H, TB2-14-A and J15-A19, TB2-14-C and J24-B17, TB2-7-L and J15-B16, TB2-7-E and XK4-7-B2. Go to paragraph 12-25. |
13. Attach P21, P22 and P431. Detach P748. Check for short between P45-3 and ground.  
**Does short exist?**
- |     |                |
|-----|----------------|
| YES | Go to step 14. |
| NO  | Go to step 16. |
14. Check for short between (A337)J1-A9 and ground.  
**Does short exist?**
- |     |   |
|-----|---|
| YES | Replace engine anti-ice relay box (TM 1-1520-238-23). |
| NO  | Go to step 15.  |

---

**12-28. ECS ENG ANTI-ICE CIRCUIT BREAKER (CB67) - DOES NOT STAY CLOSED  
(ENG INLET ON/OFF SWITCH OFF) (cont)**

---

12-28

15. Check for short between P45-3 and P21-16.  
**Does short exist?**
- YES      **(ABY)** Repair shorted wire.  
Go to paragraph 12-25.  
**(ABZ)** Replace wire harness  
(TM 1-1520-238-23).
- NO      Repair shorted wire between:  
P441-B16 and P748-M,  
J21-16 and J449-A2,  
P449-A2 and P1087-A9,  
P1087-A2 and P431-B18.  
(A402):  
J27-B18 and TB3-24-F,  
TB3-24-E and J24-B16.  
Go to paragraph 12-25.
16. Check for short between P46-3 and ground.  
**Does short exist?**
- YES      Go to step 17.
- NO      Go to step 19.
17. Check for short between (A337)J1-A3 and ground.  
**Does short exist?**
- YES      Replace engine anti-ice relay  
box (TM 1-1520-238-23).
- NO      Go to step 18.
18. Check for short between P46-3 and P22-16.  
**Does short exist?**
- YES      **(ABY)** Repair shorted wire.  
Go to paragraph 12-25.  
**(ABZ)** Replace wire harness  
(TM 1-1520-238-23).
- NO      Repair shorted wire between:  
J22-16 and P456-A13,  
J456-A13 and P1087-A3,  
P1087-A4 and P431-B20,  
P441-B15 and P748-R.  
(A402):  
J27-B20 and TB3-24-C,  
TB3-24-B and J24-B15.  
Go to paragraph 12-25.
19. Detach P33, P954 and P45. Check for short between:  
P21-14 and ground,  
P21-21 and ground,  
P21-36 and ground,  
P21-42 and ground.  
**Does short exist?**
- YES      **(ABY)** Repair shorted wire  
between:  
P21-14 and P45-1,  
P21-21 and P33-1,  
P21-36 and P45-4,  
P21-42 and P954-2.  
Go to paragraph 12-25.  
**(ABZ)** Replace wire harness  
(TM 1-1520-238-23).
- NO      Go to step 20.
20. Check for short between engine 1 L1-1 and case.  
**Does short exist?**
- YES      Replace engine 1 anti-ice valve  
L1 (TM 1-1520-238-23).
- NO      Go to step 21.
21. Check for short between engine 1 (S127-2) and case.  
**Does short exist?**
- YES      Replace engine 1 thermal switch  
S127 (TM 1-1520-238-23).
- NO      Go to step 22.
22. Check for short between (engine 1):  
E3-1 and case,  
E3-2 and case,  
E3-3 and case,  
E3-4 and case.  
**Does short exist?**
- YES      Replace engine 1 E3 anti-ice  
bleed/start valve  
(TM 1-1520-238-23).
- NO      Go to step 23.

---

**12-28. ECS ENG ANTI-ICE CIRCUIT BREAKER (CB67) - DOES NOT STAY CLOSED  
(ENG INLET ON/OFF SWITCH OFF) (cont)**

---

12-28

23. Detach P34, P46 and P953. Check for short between:

P22-14 and ground,  
P22-21 and ground,  
P22-36 and ground,  
P22-42 and ground.

**Does short exist?**

YES           **(ABY)** Repair shorted wire between:  
P22-14 and P46-1,  
P22-21 and P34-1,  
P22-36 and P46-4,  
P22-42 and P953-2.  
Go to paragraph 12-25.  
**(ABZ)** Replace wire harness (TM 1-1520-238-23).

NO            Go to step 24.

24. Check for short between engine 2 L2-1 and case.

**Does short exist?**

YES           Replace engine 2 anti-ice valve L2 (TM 1-1520-238-23).

NO            Go to step 25.

25. Check for short between engine 2 (S126-2) and case.

**Does short exist?**

YES           Replace engine 2 thermal switch S126 (TM 1-1520-238-23).

NO            Replace engine 2 anti-ice bleed/start valve E3 (TM 1-1520-238-23).

END OF TASK

**12-29. ENG 1 ANTI ICE AND ENG 2 ANTI ICE INDICATORS ON PILOT CAUTION/WARNING PANEL - LIGHT (ENG INLET ON/OFF SWITCH OFF)**

12-29

**Tools:**

<u>Nomenclature</u>	<u>Part Number</u>
Tool Kit, Electrical Repairer's	SC518099CLA06
Extractor, Relay	CTJ-RO6
Multimeter, Digital	AN/PSM-45

**Personnel Required:**

68X Armament/Electrical Systems Repairer  
One person to assist

**References:**

TM 1-1520-238-T-6  
TM 1-1520-238-23



**Turn off power before detaching or attaching wires and connectors. High current 28 VDC or 115 VAC is present. Failure to do so could result in death or serious injury.**

1. Check for 28 VDC at P178-13 .  
**Is voltage present?**

YES Go to step 3.  
NO Go to step 2.

2. Check for open between:  
P178-13 and P433-A10,  
(A402)J20-A10 and TB3-16-k,  
(A402)J1-4 and TB3-16-L.

**Does open exist?**

YES Repair open wire.  
Go to paragraph 12-25.  
NO Refer to TM 1-1520-238-T-6 to troubleshoot circuit protection system (dc essential bus 1 - pilot station).

3. On pilot **ANTI ICE** panel, set **ENG INLET ON/OFF** switch to **OFF**. Check for open between (A135):  
J1-13 and J1-34,  
J1-13 and J1-14,  
J1-14 and J1-34.  
**Does open exist?**

YES Replace pilot **ANTI ICE** panel (TM 1-1520-238-23).  
NO Go to step 4.

4. With relay (A337)K1-5/6 removed, check for 28 VDC at (A337)XK1-5/6-X1.  
**Is voltage present?**

YES Go to step 5.  
NO Go to step 7.

5. With relay (A337)K1-5/6 removed check, for open between (A337)XK1-5/6-X2 and ground.  
**Does open exist?**

YES Go to step 6.  
NO Replace relay (A337)K1-5/6 (TM 1-1520-238-23).

6. Check for open between P1087-A10 and ground.  
**Does open exist?**

YES Repair open wire.  
Go to paragraph 12-25.  
NO Replace engine anti-ice relay box (TM 1-1520-238-23).

7. With relay (A337)K1-5/6 removed, check for open between (A337):  
XK1-5/6-X1 and J1-A7.  
**Does open exist?**

YES Replace engine anti-ice relay box (TM 1-1520-238-23).  
NO Go to step 8.

---

**12-29. ENG 1 ANTI ICE AND ENG 2 ANTI ICE INDICATORS ON PILOT  
CAUTION/WARNING PANEL - LIGHT (ENG INLET ON/OFF SWITCH OFF) (cont)**

---

**12-29**

8. Check for open between:  
P433-B11 and P178-14,  
P431-B19 and P1087-A7.

**Does open exist?**

- |     |   |
|-----|---|
| YES | Repair open wire .<br>Go to paragraph 12-25.  |
| NO  | Repair open wire between<br>(A402):<br>TB2-1-T and J20-B11,<br>TB2-1-Z and J27-B19.<br>Go to paragraph 12-25. |

END OF TASK



**12-30. ENG 1 ANTI ICE INDICATOR ON PILOT CAUTION/WARNING PANEL - LIGHTS  
(ENG INLET ON/OFF SWITCH OFF)**

**12-30**

**Tools:**

<u>Nomenclature</u>	<u>Part Number</u>
Tool Kit, Electrical Repairer's	SC518099CLA06
Extractor, Relay	CTJ-RO6
Multimeter, Digital	AN/PSM-45

**Personnel Required:**

68X Armament/Electrical Systems Repairer  
One person to assist

**References:**

TM 1-1520-238-23

**Equipment Conditions:**

<u>Ref</u>	<u>Condition</u>
TM 1-1520-238-23	Access provisions - L325, T250L, T250R, T290L, T290R doors opened, L200 panel removed

**WARNING**

**Turn off power before detaching or attaching wires and connectors. High current 28 VDC or 115 VAC is present. Failure to do so could result in death or serious injury.**

1. Detach P47 and P1087. Check for 5 to 30 VDC at P1087-A1.

**Is voltage present?**

- YES Go to step 2.
- NO Go to step 6.

2. Attach P47. Check for short between P18-120 and ground.

**Does short exist?**

- YES Replace engine 1 NGB fairing (TM 1-1520-238-23).
- NO Go to step 3.

3. Attach P1087. Remove relay (A337)K1-1. Check for 28 VDC at (A337)XK1-1-X1.

**Is voltage present?**

- YES Replace engine 1 thermal switch (TM 1-1520-238-23).
- NO Go to step 4.

4. Check for short between: relay case and (A337):

- K1-1-A2,
- K1-1-A1,
- K1-1-A2.

**Does short exist?**

- YES Replace relay (A337)K1-1 (TM 1-1520-238-23).
- NO Go to step 5.

5. With relay(A337)K1-5/6 removed, check for short between (A337):

- J1-A1 and J1-A10,
- J1-A1 and ground.

**Does short exist?**

- YES Replace engine anti-ice relay box (TM 1-1520-238-23).
- NO Replace relay (A337)K1-5/6 (TM 1-1520-238-23).

6. Check for short between P18-120 and ground.

**Does short exist?**

- YES Go to step 7.
- NO Replace pilot caution/warning panel (TM 1-1520-238-23).

7. Detach P431. Check for short between P18-120 and ground.

**Does short exist?**

- YES Go to step 8.
- NO Repair shorted wire between P431-B16 and P1087-A1. Go to paragraph 12-25.

---

**12-30. ENG 1 ANTI ICE INDICATOR ON PILOT CAUTION/WARNING PANEL - LIGHTS  
(ENG INLET ON/OFF SWITCH OFF) (cont)**

---

12-30

8. Detach P441. Check for short between P18-120 and ground.

**Does short exist?**

- YES        Go to step 9.
- NO         Repair shorted wire between  
            P441-B3 and J47-E.  
            Go to paragraph 12-25.

9. Detach P438. Check for short between P18-120 and ground.

**Does short exist?**

- YES        Repair shorted wire between  
            (A402):  
            TB2-30-K and J15-B15,  
            TB2-30-J and J24-B3,  
            TB2-30-L and J27-B16.  
            Go to paragraph 12-25.
- NO         Repair shorted wire between  
            P438-B15 and P18-120.  
            Go to paragraph 12-25.

END OF TASK

**12-31. ENG 2 ANTI ICE INDICATOR ON PILOT CAUTION/WARNING PANEL - LIGHTS  
(ENG INLET ON/OFF SWITCH OFF)**

**12-31**

**Tools:**

<u>Nomenclature</u>	<u>Part Number</u>
Tool Kit, Electrical Repairer's	SC518099CLA06
Extractor, Relay	CTJ-RO6
Multimeter, Digital	AN/PSM-45

**Personnel Required:**

68X Armament/Electrical Systems Repairer  
One person to assist

**References:**

TM 1-1520-238-23

**Equipment Conditions:**

<u>Ref</u>	<u>Condition</u>
TM 1-1520-238-23	Access provisions - L325, T250L, T250R, T290L, T290R doors opened, R200 panel removed

**WARNING**

**Turn off power before detaching or attaching wires and connectors. High current 28 VDC or 115 VAC is present. Failure to do so could result in death or serious injury.**

1. Detach P48 and P1087. Check for 5 to 30 VDC at P1087-A6.

**Is voltage present?**

- YES Go to step 2.
- NO Go to step 6.

2. Attach P48. Check for short between P18-63 and ground.

**Does short exist?**

- YES Replace engine 2 NGB fairing (TM 1-1520-238-23).
- NO Go to step 3.

3. Attach P1087. With relay (A337)K1-2 removed, check for 28 VDC at (A337)XK1-2-X1.

**Is voltage present?**

- YES Replace engine 2 thermal switch (TM 1-1520-238-23).
- NO Go to step 4.

4. Check for short between (A337): relay case and K1-2-A2, K1-2-A1 and K1-2-A2.

**Does short exist?**

- YES Replace relay (A337)K1-2 (TM 1-1520-238-23).
- NO Go to step 5.

5. With relay (A337)K1-5/6 removed, check for short between (A337): J1-A6 and J1-A10, J1-A6 and ground.

**Does short exist?**

- YES Replace engine anti-ice relay box (TM 1-1520-238-23).
- NO Replace relay (A337)K1-5/6 (TM 1-1520-238-23).

6. Check for short between P18-63 and ground.

**Does short exist?**

- YES Go to step 7.
- NO Replace pilot caution/warning panel (TM 1-1520-238-23).

7. Detach P431. Check for short between P18-63 and ground.

**Does short exist?**

- YES Go to step 8.
- NO Repair shorted wire between P431-B17 and P1087-A6. Go to paragraph 12-25.

---

**12-31. ENG 2 ANTI ICE INDICATOR ON PILOT CAUTION/WARNING PANEL - LIGHTS  
(ENG INLET ON/OFF SWITCH OFF) (cont)**

---

12-31

8. Detach P440. Check for short between  
(A402)J16-B16 and ground.

**Does short exist?**

- |     |  |
|-----|--|
| YES | Repair shorted wire between<br>(A402):<br>TB2-30-P and J16-B16,<br>TB2-30-R and J27-B17,<br>TB2-30-N and J16-A3.<br>Go to paragraph 12-25. |
| NO  | Repair shorted wire between:<br>P440-B16 and P18-63,<br>P440-A3 and J48-E.<br>Go to paragraph 12-25.                                       |

END OF TASK

**12-32. ENG INLET ENG 1 AND ENG 2 ADVISORY INDICATORS ON PILOT ANTI ICE PANEL - DO NOT LIGHT (ENG INLET ON/OFF SWITCH OFF) 12-32**

**Tools:**

<u>Nomenclature</u>	<u>Part Number</u>
Tool Kit, Electrical Repairer's	SC518099CLA06
Multimeter, Digital	AN/PSM-45

**Personnel Required:**

68X Armament/Electrical Systems Repairer  
One person to assist

**References:**

TM 1-1520-238-T-6  
TM 1-1520-238-23



**Turn off power before detaching or attaching wires and connectors. High current 28 VDC or 115 VAC is present. Failure to do so could result in death or serious injury.**

1. Check for 28 VDC at P178-13.

**Is voltage present?**

- YES Go to step 2.
- NO Go to step 6.

2. Check for open between (A135): J1-13 and J1-34.

**Does open exist?**

- YES Replace pilot **ANTI ICE** panel (TM 1-1520-238-23).
- NO Go to step 3.

3. Check for open between: P178-34 and P45-4, P178-34 and P46-4.

**Does open exist?**

- YES Go to step 7.
- NO Go to step 4.

4. Check for open between: P748-L and P748-N, P748-P and P748-N.

**Does open exist?**

- YES Go to step 5.
- NO Replace multi-channel dimming controller (TM 1-1520-238-23).

5. Check for open between (A135): J1-24 and J1-18, J1-24 and J1-25.

**Does open exist?**

- YES Replace pilot **ANTI ICE** panel (TM 1-1520-238-23).
- NO Repair open wire between P748-N and P178-24. Go to paragraph 12-25.

6. Check for open between P178-13 and (A402)J1-4.

**Does open exist?**

- YES Repair open wire. Go to paragraph 12-25.
- NO Refer to TM 1-1520-238-T-6 to troubleshoot circuit protection system (dc essential bus 1 - pilot station).

7. Check for open between P178-34 and P433-A9.

**Does open exist?**

- YES Repair open wire. Go to paragraph 12-25.
- NO Repair open wire between (A402): TB3-17-B and J20-A9, TB3-17-C and TB2-7-B. Go to paragraph 12-25.

END OF TASK

**12-33. ENG INLET ENG 1 ADVISORY INDICATOR ON PILOT ANTI ICE PANEL - DOES NOT LIGHT (ENG INLET ON/OFF SWITCH OFF)**

**12-33**

**Tools:**

<u>Nomenclature</u>	<u>Part Number</u>
Tool Kit, Electrical Repairer's	SC518099CLA06
Multimeter, Digital	AN/PSM-45

**Personnel Required:**

68X Armament/Electrical Systems Repairer  
One person to assist

**References:**

TM 1-1520-238-23

**Equipment Conditions:**

<u>Ref</u>	<u>Condition</u>
TM 1-1520-238-23	Access provisions - LN1 door opened

**WARNING**

**Turn off power before detaching or attaching wires and connectors. High current 28 VDC or 115 VAC is present. Failure to do so could result in death or serious injury.**

1. Check for 28 VDC at P45-4.

**Is voltage present?**

YES Go to step 2.

NO Go to step 6.

2. Check for 28 VDC at P748-M.

**Is voltage present?**

YES Go to step 9.

NO Go to step 3.

3. Check for 28 VDC at P1087-A9.

**Is voltage present?**

YES Go to step 7.

NO Go to step 4.

4. Check for open between engine 1 anti-ice valve E3-3 and E3-4.

**Does open exist?**

YES Replace engine 1 anti-ice bleed start valve (TM 1-1520-238-23).

NO Go to step 5.

5. Check for open between P21-16 and P45-3.

**Does open exist?**

YES **(ABY)** Repair open wire. Go to paragraph 12-25.  
**(ABZ)** Replace wire harness (TM 1-1520-238-23).

NO Repair open wire between: J449-A2 and J21-16, P449-A2 and P1087-A9. Go to paragraph 12-25.

6. Check for open between P21-36 and P45-4.

**Does open exist?**

YES **(ABY)** Repair open wire. Go to paragraph 12-25.  
**(ABZ)** Replace wire harness (TM 1-1520-238-23).

NO Repair open wire between: J21-36 and P441-B17. (A402): J24-B17 and TB2-14-C, TB2-14-B and TB2-7-H. Go to paragraph 12-25.

7. Check for open between (A337):

J1-A2 and J1-A9.

**Does open exist?**

YES Replace engine anti-ice relay box (TM 1-1520-238-23).

NO Go to step 8.

---

**12-33. ENG INLET ENG 1 ADVISORY INDICATOR ON PILOT ANTI ICE PANEL - DOES NOT LIGHT (ENG INLET ON/OFF SWITCH OFF) (cont)**

---

12-33

8. Check for open between:  
P441-B16 and P748-M,  
P431-B18 and P1087-A2.

**Does open exist?**

- |     |  |
|-----|--|
| YES | Repair open wire. Go to paragraph 12-25.   |
| NO  | Repair open wire between (A402):<br>TB3-24-E and J24-B16,<br>TB3-24-F and J27-B18.<br>Go to paragraph 12-25. |

9. Check for open between P748-L and P748-N.

**Does open exist?**

- |     |                |
|-----|----------------|
| YES | Go to step 12. |
| NO  | Go to step 10. |

10. On pilot **ANTI ICE** panel, remove **ENG INLET** light XDS2 (TM 1-1520-238-23). Check for short between:

P748-L and P748-N,  
P748-L and ground.

**Does short exist?**

- |     |  |
|-----|--|
| YES | Go to step 11.   |
| NO  | Replace multi-channel dimming controller (TM 1-1520-238-23). |

11. Detach P178. Check for short between:

P748-L and P748-N,  
P748-L and ground.

**Does short exist?**

- |     |   |
|-----|---|
| YES | Repair shorted wire.<br>Go to paragraph 12-25.          |
| NO  | Replace pilot <b>ANTI ICE</b> panel (TM 1-1520-238-23). |

12. Check for open between P748-L and P178-18.

**Does open exist?**

- |     |   |
|-----|---|
| YES | Repair open wire.<br>Go to paragraph 12-25.             |
| NO  | Replace pilot <b>ANTI ICE</b> panel (TM 1-1520-238-23). |

END OF TASK

**12-34. ENG INLET ENG 2 ADVISORY INDICATOR ON PILOT ANTI ICE PANEL - DOES NOT LIGHT (ENG INLET ON/OFF SWITCH OFF)**

**Tools:**

<u>Nomenclature</u>	<u>Part Number</u>
Tool Kit, Electrical Repairer's	SC518099CLA06
Multimeter, Digital	AN/PSM-45

**Personnel Required:**

68X Armament/Electrical Systems Repairer  
One person to assist

**References:**

TM 1-1520-238-23

**Equipment Conditions:**

<u>Ref</u>	<u>Condition</u>
TM 1-1520-238-23	Access provisions - RN1 door opened



**Turn off power before detaching or attaching wires and connectors. High current 28 VDC or 115 VAC is present. Failure to do so could result in death or serious injury.**

1. Check for 28 VDC at P46-4.

**Is voltage present?**

YES Go to step 2.

NO Go to step 8.

2. Check for 28 VDC at P748-R.

**Is voltage present?**

YES Go to step 9.

NO Go to step 3.

3. Check for 28 VDC at P1087-A3.

**Is voltage present?**

YES Go to step 6.

NO Go to step 4.

4. Check for open between engine 2 anti-ice valve E3-3 and E3-4.

**Does open exist?**

YES Replace engine 2 anti-ice bleed start valve (TM 1-1520-238-23).

NO Go to step 5.

5. Check for open between P22-16 and P46-3.

**Does open exist?**

YES **(ABY)** Repair open wire. Go to paragraph 12-25.

**(ABZ)** Replace wire harness (TM 1-1520-238-23).

NO Repair open wire between: P456-A13 and J22-16, J449-A13 and P1087-A3. Go to paragraph 12-25.

6. Check for open between (A337): J1-A4 and J1-A3.

**Does open exist?**

YES Replace engine anti-ice relay box (TM 1-1520-238-23).

NO Go to step 7.

7. Check for open between: P441-B15 and P748-R, P431-B20 and P1087-A4.

**Does open exist?**

YES Repair open wire. Go to paragraph 12-25.

NO Repair open wire between (A402): TB3-24-B and J24-B15, TB3-24-C and J27-B20. Go to paragraph 12-25.



---

**12-34. ENG INLET ENG 2 ADVISORY INDICATOR ON PILOT ANTI ICE PANEL - DOES NOT LIGHT (ENG INLET ON/OFF SWITCH OFF) (cont)**

---

12-34

8. Check for open between P22-36 and P46-4.

**Does open exist?**

- |     |  |
|-----|--|
| YES | ( <b>ABY</b> ) Repair open wire.<br>Go to paragraph 12-25.<br>( <b>ABZ</b> ) Replace wire harness<br>(TM 1-1520-238-23). |
| NO  | Repair open wire between:<br>J22-36 and P438-B16.<br>(A402):<br>J15-B16 and TB2-7-L.<br>Go to paragraph 12-25.           |

9. Check for open between P748-P and P748-N.

**Does open exist?**

- |     |                |
|-----|----------------|
| YES | Go to step 12. |
| NO  | Go to step 10. |

10. On pilot **ANTI ICE** panel, remove **ENG INLET** light XDS2 (TM 1-1520-238-23). Check for short between:  
P748-P and P748-N,  
P748-P and ground.

**Does short exist?**

- |     |  |
|-----|--|
| YES | Go to step 11.   |
| NO  | Replace multi-channel dimming controller (TM 1-1520-238-23). |

11. Detach P178. Check for short between:  
P748-P and P748-N,  
P748-P and ground.

**Does short exist?**

- |     |  |
|-----|--|
| YES | Repair shorted wire.<br>Go to paragraph 12-25.             |
| NO  | Replace pilot <b>ANTI ICE</b> panel<br>(TM 1-1520-238-23). |

12. Check for open between P748-P and P178-25.

**Does open exist?**

- |     |  |
|-----|--|
| YES | Repair open wire.<br>Go to paragraph 12-25.                |
| NO  | Replace pilot <b>ANTI ICE</b> panel<br>(TM 1-1520-238-23). |

END OF TASK

---

**12-35. ECS L NOSE GRBX HTR CIRCUIT BREAKER (CB38) - DOES NOT STAY CLOSED  
(ENG INLET ON/OFF SWITCH ON)**

---

**Tools:**

<u>Nomenclature</u>	<u>Part Number</u>
Tool Kit, Electrical Repairer's	SC518099CLA06

**Personnel Required:**

68X Armament/Electrical Systems Repairer

**References:**

TM 1-1520-238-23

**Equipment Conditions:**

<u>Ref</u>	<u>Condition</u>
TM 1-1520-238-23	Access provisions - L200 panel removed

---

**WARNING**

**Turn off power before detaching or attaching wires and connectors. High current 28 VDC or 115 VAC is present. Failure to do so could result in death or serious injury.**

Detach (HR3)P2 and close CB38.

**Does circuit breaker stay closed?**

- YES      Replace left upper aft fairing  
(TM 1-1520-238-23).
- NO        Replace left NGB fairing  
(TM 1-1520-238-23).

END OF TASK

**12-36. ECS ENG ANTI-ICE CIRCUIT BREAKER (CB67) - DOES NOT STAY CLOSED  
(ENG INLET ON/OFF SWITCH ON)**

**12-36**

**Tools:**

<u>Nomenclature</u>	<u>Part Number</u>
Tool Kit, Electrical Repairer's	SC518099CLA06
Extractor, Relay	CTJ-RO6
Multimeter, Digital	AN/PSM-45

**Personnel Required:**

68F Aircraft Electrician

**References:**

TM 1-1520-238-23

**Equipment Conditions:**

<u>Ref</u>	<u>Condition</u>
TM 1-1520-238-23	Access provisions - LN1 door opened

**WARNING**

**Turn off power before detaching or attaching wires and connectors. High current 28 VDC or 115 VAC is present. Failure to do so could result in death or serious injury.**

1. Check for 320 ±20 ohms resistance between P954-1 and ground.

**Is resistance present?**

YES      Go to step 2.  
NO        Go to step 5.

2. Detach P1087. Check for short between P953-1 and ground.

**Does short exist?**

YES      Go to step 3.  
NO        Go to step 4.

3. Check for short between P953-1 and ground.

**Does short exist?**

YES      **(ABY)** Repair shorted wire. Go to paragraph 12-25.  
**(ABZ)** Replace wire harness (TM 1-1520-238-23).  
  
NO        Repair shorted wire between: J22-37 and P456-A14, J456-A14 and P1087-A5. Go to paragraph 12-25.

4. Remove relay (A337)K1-2. Check for short between (A337)J1-A5 and ground.

**Does short exist?**

YES      Repair shorted wire between (A337): J1-A5 and XK1-2-X1. Go to paragraph 12-25.  
  
NO        Replace relay (A337)K1-2 (TM 1-1520-238-23).

5. Detach P1087. Check for short between P954-1 and ground.

**Does short exist?**

YES      Go to step 7.  
NO        Go to step 6.

6. Remove relay (A337)K1-1. Check for short between (A337)J1-A8 and ground.

**Does short exist?**

YES      Repair shorted wire between (A337): J1-48 and XK1-1-X1. Go to paragraph 12-25.  
  
NO        Replace relay (A337)K1-1 (TM 1-1520-238-23).

---

**12-36. ECS ENG ANTI-ICE CIRCUIT BREAKER (CB67) - DOES NOT STAY CLOSED  
(ENG INLET ON/OFF SWITCH ON) (cont)**

---

**12-36**

7. Check for short between P954-1 and ground.

**Does short exist?**

- |     |   |
|-----|---|
| YES | <b>(ABY)</b> Repair shorted wire.<br>Go to paragraph 12-25.<br><b>(ABZ)</b> Replace wire harness<br>(TM 1-1520-238-23). |
| NO  | Repair shorted wire between:<br>J21-37 and J449-A1,<br>P449-A1 and P1087-A8.<br>Go to paragraph 12-25.                  |

END OF TASK

**12-37. ECS ENG ANTI-ICE CIRCUIT BREAKER (CB67) - DOES NOT STAY CLOSED  
(ENG INLET ON/OFF SWITCH ON)**

12-37

**Tools:**

<u>Nomenclature</u>	<u>Part Number</u>
Tool Kit, Electrical Repairer's	SC518099CLA06
Multimeter, Digital	AN/PSM-45

**Personnel Required:**

68X Armament/Electrical Systems Repairer

**References:**

TM 1-1520-238-23

**Equipment Conditions:**

<u>Ref</u>	<u>Condition</u>
TM 1-1520-238-23	Access provisions - R200 and L200 panels removed

<b>WARNING</b>
----------------

**Turn off power before detaching or attaching wires and connectors. High current 28 VDC or 115 VAC is present. Failure to do so could result in death or serious injury.**

1. Detach P47 and P48. Check for short between (A402)J1-4 and ground.

**Does short exist?**

YES	Go to step 2.
NO	Go to step 4.

2. Check for short between (A135)J1-15 and chassis ground.

**Does short exist?**

YES	Replace pilot <b>ANTI ICE</b> panel (TM 1-1520-238-23).
NO	Go to step 3.

3. Detach P433. Check for short between P178-15 and ground.

**Does short exist?**

YES	Repair shorted wire between P433-A15 and P178-15. Go to paragraph 12-25.
NO	Repair shorted wire between (A402): TB2-14-E and J20-A15, TB2-14-F and J16-A2, TB2-14-D and J24-B6, TB3-16-L and J1-4, TB3-16-M and XK5-10-A2, TB3-16-K and J20-A10. Go to paragraph 12-25.

4. Attach P47. Check for short between P441-B6 and ground.

**Does short exist?**

YES	Go to step 5.
NO	Go to step 6.

5. Check for short between P47-A and ground.

**Does short exist?**

YES	Replace engine 1 NGB fairing (TM 1-1520-238-23).
NO	Repair shorted wire between P441-B6 and J47-A. Go to paragraph 12-25.

6. Check for short between P48-A and ground.

**Does short exist?**

YES	Replace engine 2 NGB fairing (TM 1-1520-238-23).
NO	Repair shorted wire between J48-A and P440-A2. Go to paragraph 12-25.

END OF TASK

**12-38. ENG 1 ANTI ICE AND ENG 2 ANTI ICE INDICATORS ON PILOT CAUTION/WARNING PANEL - DO NOT LIGHT (ENG INLET ON/OFF SWITCH ON)** **12-38**

**Tools:**

<u>Nomenclature</u>	<u>Part Number</u>
Tool Kit, Electrical Repairer's	SC518099CLA06
Extractor, Relay	CTJ-RO6
Multimeter, Digital	AN/PSM-45

**Personnel Required:**

68X Armament/Electrical Systems Repairer  
One person to assist

**References:**

TM 1-1520-238-T-6  
TM 1-1520-238-23

**Equipment Conditions:**

<u>Ref</u>	<u>Condition</u>
TM 1-1520-238-23	Access provisions - T250L, T250R, T290L, T290R, and L325 doors opened

**WARNING**

**Turn off power before detaching or attaching wires and connectors. High current 28 VDC or 115 VAC is present. Failure to do so could result in death or serious injury.**

1. With relay (A337)K1-5/6 removed, check for 5 to 30 VDC at (A337):  
XK1-5/6-C3,  
XK1-5/6-D3.  
**Is voltage present?**

YES	Go to step 2.
NO	Refer to TM 1-1520-238-T-6 to troubleshoot pilot caution/warning system.

2. Check for open between (A337):  
XK1-5/6-C2 and ground,  
XK1-5/6-D2 and ground.  
**Does open exist?**

YES	Go to step 5.
NO	Go to step 3.
3. With relay (A337)K1-5/6 removed, check for 28 VDC at (A337)XK1-5/6-X1.  
**Is voltage present?**

YES	Go to step 4.
NO	Replace relay (A337)K1-5/6 (TM 1-1520-238-23).
4. With relays (A402)K4-7 and (A337)K1-5/6 removed, check for 28 VDC at (A337)XK1-5/6-X1.  
**Is voltage present?**

YES	Replace pilot <b>ANTI ICE</b> panel (TM 1-1520-238-23).
NO	Replace relay (A402)K4-7 (TM 1-1520-238-23).
5. Check for open between P1087-A10 and ground.  
**Does open exist?**

YES	Repair open wire. Go to paragraph 12-25.
NO	Replace engine anti-ice relay box (TM 1-1520-238-23).

END OF TASK

**12-39. ENG 1 ANTI ICE INDICATOR ON PILOT CAUTION/WARNING PANEL - DOES NOT LIGHT (ENG INLET ON/OFF SWITCH ON)**

12-39

**Tools:**

<u>Nomenclature</u>	<u>Part Number</u>
Tool Kit, Electrical Repairer's	SC518099CLA06
Extractor, Relay	CTJ-RO6
Multimeter, Digital	AN/PSM-45

**Personnel Required:**

68X Armament/Electrical Systems Repairer  
One person to assist

**References:**

TM 1-1520-238-T-6  
TM 1-1520-238-23

**Equipment Conditions:**

<u>Ref</u>	<u>Condition</u>
TM 1-1520-238-23	Access provisions - L325, T250L, T250R, T290L and T290R doors opened

**WARNING**

**Turn off power before detaching or attaching wires and connectors. High current 28 VDC or 115 VAC is present. Failure to do so could result in death or serious injury.**

1. Check for 5 to 30 VDC at P1087-A1.  
**Is voltage present?**

YES Go to step 4.  
NO Go to step 2.

2. Check for open between P18-120 and P1087-A1.  
**Does open exist?**

YES Go to step 3.  
NO Refer to TM 1-1520-238-T-6 to troubleshoot pilot caution/warning system.

3. Check for open between (A402): J15-B15 and J27-B16.

**Does open exist?**

YES Repair open wire.  
NO Repair open wire between: P438-B15 and P18-120, P431-B16 and P1087-A1. Go to paragraph 12-25.

4. With relay (A337)K1-5/6 removed, check for 5 to 30 VDC at (A337)XK1-5/6-D3.

**Is voltage present?**

YES Go to step 7.  
NO Go to step 5.

5. With relay (A337)K1-1 removed, check for 5 to 30 VDC at (A337)XK1-1-A2.

**Is voltage present?**

YES Go to step 6.  
NO Replace engine anti-ice relay box (TM 1-1520-238-23).

6. Check for open between (A337): K1-1-A2 and K1-1-A3.

**Does open exist?**

YES Replace relay (A337)K1-1 (TM 1-1520-238-23).  
NO Replace engine anti-ice relay box (TM 1-1520-238-23).

7. Check for open between (A337)XK1-5/6-D2 and ground.

**Does open exist?**

YES Replace engine anti-ice relay box (TM 1-1520-238-23).  
NO Replace relay (A337)K1-5/6 (TM 1-1520-238-23).

END OF TASK

**12-40. ENG 2 ANTI ICE INDICATOR ON PILOT CAUTION/WARNING PANEL - DOES NOT LIGHT (ENG INLET ON/OFF SWITCH ON)**

**12-40**

**Tools:**

<u>Nomenclature</u>	<u>Part Number</u>
Tool Kit, Electrical Repairer's	SC518099CLA06
Extractor, Relay	CTJ-RO6
Multimeter, Digital	AN/PSM-45

**Personnel Required:**

68X Armament/Electrical Systems Repairer  
One person to assist

**References:**

TM 1-1520-238-T-6  
TM 1-1520-238-23

**Equipment Conditions:**

<u>Ref</u>	<u>Condition</u>
TM 1-1520-238-23	Access provisions - L325, T250L, T250R, T290L and T290R doors opened

**WARNING**

**Turn off power before detaching or attaching wires and connectors. High current 28 VDC or 115 VAC is present. Failure to do so could result in death or serious injury.**

1. Check for 5 to 30 VDC at P1087-A6.  
**Is voltage present?**

YES Go to step 4.  
NO Go to step 2.

2. Check for open between P18-63 and P1087-A6.  
**Does open exist?**

YES Go to step 3.  
NO Refer to TM 1-1520-238-T-6 to troubleshoot pilot caution/warning system.

3. Check for open between (A402): J16-B16 and J27-B17.

**Does open exist?**

YES Repair open wire between (A402): TB2-30-P and J16-B16, TB2-30-R and J27-B17. Go to paragraph 12-25.

NO Repair open wire between: P440-B16 and P18-63, P431-B17 and P1087-A6. Go to paragraph 12-25.

4. With relay (A337)K1-5/6 removed, check for 5 to 30 VDC at (A337)XK1-5/6-C3.

**Is voltage present?**

YES Go to step 7.  
NO Go to step 5.

5. With relay (A337)K1-2 removed, check for 5 to 30 VDC at (A337)XK1-2-A2.

**Is voltage present?**

YES Go to step 6.  
NO Replace engine anti-ice relay box (TM 1-1520-238-23).

6. Check for open between (A337): K1-2-A2 and K1-2-A3.

**Does open exist?**

YES Replace relay (A337)K1-2 (TM 1-1520-238-23).  
NO Replace engine anti-ice relay box (TM 1-1520-238-23).

7. Check for open between (A337)XK1-5/6-C2 and ground.

**Does open exist?**

YES Replace engine anti-ice relay box (TM 1-1520-238-23).  
NO Replace relay (A337)K1-5/6 (TM 1-1520-238-23).

END OF TASK



**12-41. ENG 1 NOSE GEARBOX FAIRING - DOES NOT GET HOT (ENG INLET ON/OFF SWITCH ON)**

12-41

**Tools:**

<u>Nomenclature</u>	<u>Part Number</u>
Tool Kit, Electrical Repairer's	SC518099CLA06
Multimeter, Digital	AN/PSM-45

**Personnel Required:**

68X Armament/Electrical Systems Repairer  
One person to assist

**References:**

TM 1-1520-238-T-6  
TM 1-1520-238-23

**Equipment Conditions:**

<u>Ref</u>	<u>Condition</u>
TM 1-1520-238-23	Access provisions - L200 panel removed

**WARNING**

- Turn off power before detaching or attaching wires and connectors. High current 28 VDC or 115 VAC is present. Failure to do so could result in death or serious injury.
- Do not touch engine 1 or engine 2 nose gearbox or upper aft fairings when ENG INLET ON/OFF switch is set to ON. Heaters in these fairings can cause serious burns.

1. Check for 115 VAC between:  
J47-G and J47-C,  
J47-L and J47-C,  
J47-M and J47-C.

**Is voltage present?**

YES Go to step 4.

NO Go to step 2.

2. Check for open between J47-C and ground.  
**Does open exist?**

YES Repair open wire.  
Go to paragraph 12-25.

NO Go to step 3.

3. Check for open between:  
(A402)J2-m and J47-G,  
(A402)J2-n and J47-L,  
(A402)J2-p and J47-M.

**Does open exist?**

YES Repair open wire.  
Go to paragraph 12-25.

NO Refer to TM 1-1520-238-T-6 to troubleshoot circuit protection system (ac essential bus 1 - pilot station).

4. Check for 28 VDC between J47-A and J47-B.  
**Is voltage present?**

YES Replace engine 1 NGB fairing (TM 1-1520-238-23).

NO Go to step 5.

5. Check for open between J47-B and ground.  
**Does open exist?**

YES Repair open wire.  
Go to paragraph 12-25.

NO Go to step 6.

6. Check for open between P178-15 and J47-A.  
**Does open exist?**

YES Repair open wire.  
Go to paragraph 12-25.

NO Replace pilot **ANTI ICE** panel (TM 1-1520-238-23).

END OF TASK

**12-42. ENG 2 NOSE GEARBOX FAIRING - DOES NOT GET HOT (ENG INLET ON/OFF SWITCH ON) 12-42**

**Tools:**

<u>Nomenclature</u>	<u>Part Number</u>
Tool Kit, Electrical Repairer's	SC518099CLA06
Multimeter, Digital	AN/PSM-45

**Personnel Required:**

68X Armament/Electrical Systems Repairer  
One person to assist

**References:**

TM 1-1520-238-T-6  
TM 1-1520-238-23

**Equipment Conditions:**

<u>Ref</u>	<u>Condition</u>
TM 1-1520-238-23	Access provisions - R200 panel removed

**WARNING**

- Turn off power before detaching or attaching wires and connectors. High current 28 VDC or 115 VAC is present. Failure to do so could result in death or serious injury.
- Do not touch engine 1 or engine 2 nose gearbox or upper aft fairings when ENG INLET ON/OFF switch is set to ON. Heaters in these fairings can cause serious burns. If burns occur, seek medical aid.

1. Check for 115 VAC between:  
J48-G and J48-C,  
J48-L and J48-C,  
J48-M and J48-C.

**Is voltage present?**

YES Go to step 4.  
NO Go to step 2.

2. Check for open between J48-C and ground.  
**Does open exist?**

YES Repair open wire between J48-C and GS443-C. Go to paragraph 12-25.  
NO Go to step 3.

3. Check for open between:  
J48-G and P19-A  
J48-L and P19-B  
J48-M and P19-C

(A402)J2-q and J19-A,  
(A402)J2-r and J19-B,  
(A402)J2-s and J19-C.

**Does open exist?**

YES Repair open wire. Go to paragraph 12-25.  
NO Refer to TM 1-1520-238-T-6 to troubleshoot circuit protection system (ac essential bus 1 - pilot station).

4. Check for 28 VDC between J48-A and J48-B.  
**Is voltage present?**

YES Replace engine 2 NGB fairing (TM 1-1520-238-23).  
NO Go to step 5.

5. Check for open between J48-B and ground.  
**Does open exist?**

YES Repair open wire between:  
**(AAG)** J48-B and GS541-D.  
**(ABC)** J48-B and GS542-L.  
Go to paragraph 12-25.  
NO Go to step 6.

6. Check for open between:  
J48-A and P440-A2,  
(A402)J16-A2 and TB2-14-F,  
(A402)TB2-14-E and J20-A15,  
P433-A15 and P178-15.

**Does open exist?**

YES Repair open wire. Go to paragraph 12-25.  
NO Replace pilot **ANTI ICE** panel (TM 1-1520-238-23).

END OF TASK

**12-43. ENG 1 AND ENG 2 ANTI ICE INDICATORS ON PILOT CAUTION/WARNING PANEL - REMAIN LIGHTED (ENG INLET ON/OFF SWITCH ON, ENG START SWITCH NO 1 OR NO 2 SET TO IGN OVRD)**

12-43

**Tools:**

<u>Nomenclature</u>	<u>Part Number</u>
Tool Kit, Electrical Repairer's	SC518099CLA06
Extractor, Relay	CTJ-RO6
Multimeter, Digital	AN/PSM-45

**Personnel Required:**

68X Armament/Electrical Systems Repairer

**References:**

TM 1-1520-238-T-4  
 TM 1-1520-238-23

**Equipment Conditions:**

<u>Ref</u>	<u>Condition</u>
TM 1-1520-238-23	Electrical power distribution box cover removed

**WARNING**

**Turn off power before detaching or attaching wires and connectors. High current 28 VDC or 115 VAC is present. Failure to do so could result in death or serious injury.**

1. With relay (A402)K4-7 removed, check for 28 VDC at (A402)XK4-7-B2.

**Is voltage present?**

- |     |   |
|-----|---|
| YES | Go to step 2.   |
| NO  | Repair open wire between (A402):<br>XK4-7-B2 and TB2-7-E.<br>Go to paragraph 12-25. |

2. With relay (A402)K4-7 removed, check for open between:  
(A402)XK4-7-B1 and TB3-9-F,  
(A402)TB3-9-E and TB2-1-Y,  
(A402)TB2-1-T and P178-14.

**Does open exist?**

- |     |                   |
|-----|-------------------|
| YES | Repair open wire. |
| NO  | Go to step 3.     |

3. With relay (A402)K4-7 removed, check for open between (A402)XK4-7-X2 and ground.

**Does open exist?**

- |     |  |
|-----|--|
| YES | Repair open wire between (A402)XK4-7-X2 and GS7-F.<br>Go to paragraph 12-25. |
| NO  | Go to step 4.  |

4. With relay (A402)K4-7 removed, check for 320 ±20 ohms between relay (A402):  
K4-7-X1 and K4-7-X2.

**Is resistance present?**

- |     |  |
|-----|--|
| YES | Refer to TM 1-1520-238-T-4 to troubleshoot power plants. |
| NO  | Replace relay (A402)K4-7 (TM 1-1520-238-23).             |

END OF TASK

**12-44. ENG 1 ANTI ICE INDICATOR ON PILOT CAUTION/WARNING PANEL - LIGHTS  
(ENG INLET ON/OFF SWITCH OFF, ENGINE RUNNING)**

**12-44**

**Tools:**

<u>Nomenclature</u>	<u>Part Number</u>
Tool Kit, Electrical Repairer's	SC518099CLA06
Multimeter, Digital	AN/PSM-45

**Personnel Required:**

68X Armament/Electrical Systems Repairer  
One person to assist

**References:**

TM 1-1520-238-23

**Equipment Conditions:**

<u>Ref</u>	<u>Condition</u>
TM 1-1520-238-23	Access provisions - LN1 door opened

**WARNING**

**Turn off power before detaching or attaching wires and connectors. High current 28 VDC or 115 VAC is present. Failure to do so could result in death or serious injury.**

1. Check for 28 VDC at P33-1.

**Is voltage present?**

YES Go to step 2.

NO Go to step 4.

2. Check for open between P33-3 and ground.

**Does open exist?**

YES Go to step 3.

NO Replace engine 1 inlet anti-ice valve (TM 1-1520-238-23).

3. Check for open between P33-3 and P21-22.

**Does open exist?**

YES **(ABY)** Repair open wire. Go to paragraph 12-25.  
**(ABZ)** Replace wire harness (TM 1-1520-238-23).

NO Repair open wire between J21-22 and GS574-H. Go to paragraph 12-25.

4. Check for open between P21-21 and P33-1.

**Does open exist?**

YES **(ABY)** Repair open wire. Go to paragraph 12-25.  
**(ABZ)** Replace wire harness (TM 1-1520-238-23).

NO Repair open wire between: P439-A3 and J21-21. (A402): J21-A3 and TB3-9-C. Go to paragraph 12-25.

END OF TASK

**12-45. ENG 2 ANTI ICE INDICATOR ON PILOT CAUTION/WARNING PANEL - LIGHTS (ENG INLET ON/OFF SWITCH OFF, ENGINE RUNNING) 12-45**

**Tools:**

<u>Nomenclature</u>	<u>Part Number</u>
Tool Kit, Electrical Repairer's	SC518099CLA06
Multimeter, Digital	AN/PSM-45

**Personnel Required:**

68X Armament/Electrical Systems Repairer  
One person to assist

**References:**

TM 1-1520-238-23

**Equipment Conditions:**

<u>Ref</u>	<u>Condition</u>
TM 1-1520-238-23	Access provisions - RN1 door opened

**WARNING**

**Turn off power before detaching or attaching wires and connectors. High current 28 VDC or 115 VAC is present. Failure to do so could result in death or serious injury.**

1. Check for 28 VDC at P34-1.

**Is voltage present?**

YES Go to step 2.

NO Go to step 4.

2. Check for open between P34-3 and ground.

**Does open exist?**

YES Go to step 3.

NO Replace engine 2 inlet anti-ice valve (TM 1-1520-238-23).

3. Check for open between P34-3 and P22-22.

**Does open exist?**

YES **(ABY)** Repair open wire. Go to paragraph 12-25.  
**(ABZ)** Replace wire harness (TM 1-1520-238-23).

NO Repair open wire between J22-22 and GS542-H. Go to paragraph 12-25.

4. Check for open between P22-21 and P34-1.

**Does open exist?**

YES **(ABY)** Repair open wire. Go to paragraph 12-25.  
**(ABZ)** Replace wire harness (TM 1-1520-238-23).

NO Repair open wire between: P438-A3 and J22-21. (A402): J15-A3 and TB3-9-A. Go to paragraph 12-25.

END OF TASK

**12-46. ENG INLET ENG 1 ADVISORY INDICATOR ON PILOT ANTI ICE PANEL - REMAINS LIGHTED (ENG INLET ON/OFF SWITCH OFF, ENG 1 N<sub>G</sub> RPM BETWEEN 90 AND 92%)** **12-46**

**Tools:**

Nomenclature	Part Number
Tool Kit, Electrical Repairer's	SC518099CLA06
Multimeter, Digital	AN/PSM-45

**Personnel Required:**

68X Armament/Electrical Systems Repairer  
 One person to assist  
 152FG Pilot

**References:**

TM 1-1520-238-23  
 TM 1-1520-238-CL

**Equipment Conditions:**

Ref	Condition
TM 1-1520-238-23	Access provisions - LN1 door opened

**WARNING**

**Turn off power before detaching or attaching wires and connectors. High current 28 VDC or 115 VAC is present. Failure to do so could result in death or serious injury.**

1. Check for 28 VDC between P45-1 and P45-2.  
**Is voltage present?**

YES	Go to step 2.
NO	Go to step 3.

2. Detach P748. Depin P748-M and attach P748. Start and run engine 1 above 90% N<sub>G</sub> (TM 1-1520-238-CL). On pilot **ANTI ICE** panel, set **ENG INLET ON/OFF** switch to **OFF**. Check for 28 VDC at wire end of P748-M.

**Is voltage present?**

YES	Replace engine 1 anti-ice bleed start valve (TM 1-1520-238-23).
NO	Replace multi-channel dimming controller (TM 1-1520-238-23).

3. Check for open between P45-2 and ground.  
**Does open exist?**

YES	Go to step 4.
NO	Go to step 5.

4. Check for open between P21-15 and P45-2.  
**Does open exist?**

YES	<b>(ABY)</b> Repair open wire. Go to paragraph 12-25. <b>(ABZ)</b> Replace wire harness (TM 1-1520-238-23).
NO	Repair open wire between J21-15 and GS574-G. Go to paragraph 12-25.

5. Check for open between P21-14 and P45-1.  
**Does open exist?**

YES	<b>(ABY)</b> Repair open wire. Go to paragraph 12-25. <b>(ABZ)</b> Replace wire harness (TM 1-1520-238-23).
NO	Repair open wire between: P439-A4 and J21-14. (A402): J21-A4 and TB3-9-D. Go to paragraph 12-25.

END OF TASK

**12-47. ENG INLET ENG 2 ADVISORY INDICATOR ON PILOT ANTI ICE PANEL - REMAINS LIGHTED (ENG INLET ON/OFF SWITCH OFF, ENG 2  $N_G$  RPM BETWEEN 90 AND 92%)** **12-47**

**Tools:**

<u>Nomenclature</u>	<u>Part Number</u>
Tool Kit, Electrical Repairer's	SC518099CLA06
Multimeter, Digital	AN/PSM-45

**Personnel Required:**

68X Armament/Electrical Systems Repairer  
 One person to assist  
 152FG Pilot

**References:**

TM 1-1520-238-23  
 TM 1-1520-238-CL

**Equipment Conditions:**

<u>Ref</u>	<u>Condition</u>
TM 1-1520-238-23	Access provisions - LN1 door opened

**WARNING**

**Turn off power before detaching or attaching wires and connectors. High current 28 VDC or 115 VAC is present. Failure to do so could result in death or serious injury.**

1. Check for 28 VDC between P46-1 and P46-2.  
**Is voltage present?**

YES	Go to step 2.
NO	Go to step 3.

2. Detach P748. Depin P748-R and attach P748. Start and run engine 2 above 90%  $N_G$  (TM 1-1520-238-CL). On pilot **ANTI ICE** panel, set **ENG INLET ON/OFF** switch to **OFF**. Check for 28 VDC at wire end of P748-R.

**Is voltage present?**

YES	Replace engine 2 anti-ice bleed start valve (TM 1-1520-238-23).
NO	Replace multi-channel dimming controller (TM 1-1520-238-23).

3. Check for open between P46-2 and ground.  
**Does open exist?**

YES	Go to step 4.
NO	Go to step 5.

4. Check for open between P22-15 and P46-2.  
**Does open exist?**

YES	<b>(ABY)</b> Repair open wire. Go to paragraph 12-25. <b>(ABZ)</b> Replace wire harness (TM 1-1520-238-23).
NO	Repair open wire between J22-15 and GS542-G. Go to paragraph 12-25.

5. Check for open between P22-14 and P46-1.  
**Does open exist?**

YES	<b>(ABY)</b> Repair open wire. Go to paragraph 12-25. <b>(ABZ)</b> Replace wire harness (TM 1-1520-238-23).
NO	Repair open wire between: P438-A4 and J22-14. (A402): J15-A4 and TB3-9-B. Go to paragraph 12-25.

END OF TASK

**12-48. ENG 1 ANTI ICE INDICATOR ON PILOT CAUTION/WARNING PANEL - LIGHTS  
(ENG INLET ON/OFF SWITCH ON, ENGINES RUNNING)**

**12-48**

**Tools:**

<u>Nomenclature</u>	<u>Part Number</u>
Tool Kit, Electrical Repairer's	SC518099CLA06
Extractor, Relay	CTJ-RO6
Heater, Gun Type Electric	MIL-H-45193
Multimeter, Digital	AN/PSM-45

**Personnel Required:**

68X Armament/Electrical Systems Repairer  
One person to assist

**References:**

TM 1-1520-238-23

**Equipment Conditions:**

<u>Ref</u>	<u>Condition</u>
TM 1-1520-238-23	Access provisions - T250L, T250R, T290L, T290R, and L325 doors opened

**WARNING**

- **Turn off power before detaching or attaching wires and connectors. High current 28 VDC or 115 VAC is present. Failure to do so could result in death or serious injury.**
- **When using heater gun, avoid contact with skin. Heater gun can cause serious burns and start fires. Wear protective equipment. Avoid touching heated parts. If burns occur, get medical help immediately.**

1. Detach P954. Remove engine 1 thermal switch. Attach P954 to thermal switch. Remove relay (A337)K1-1. Direct heat from heat gun onto thermal switch. Allow a minute for switch to heat. On pilot **ANTI ICE** panel, set **ENG INLET ON/OFF** switch to **ON**. Check for 28 VDC at (A337)XK1-1-X1.

**Is voltage present?**

YES      Go to step 9.  
NO        Go to step 2.

2. Apply heat to thermal switch while checking for open between pins S127-1 and S127-2. Allow a minute for switch to heat.
- Does open exist?**
- YES      Replace engine 1 thermal switch (TM 1-1520-238-23).  
NO        Go to step 3.
3. Check for 28 VDC at P954-2.
- Is voltage present?**
- YES      Go to step 5.  
NO        Go to step 4.
4. Check for open between P954-2 and P21-42.
- Does open exist?**
- YES      **(ABY)** Repair open wire. Go to paragraph 12-25.  
**(ABZ)** Replace wire harness (TM 1-1520-238-23).  
NO        Repair open wire between: P439-A6 and J21-42. (A402): J21-A6 and TB3-17-A. Go to paragraph 12-25.
5. With relay (A337)K1-1 removed, check for open between (A337)XK1-1-X1 and P954-1.
- Does open exist?**
- YES      Go to step 6.  
NO        Replace engine 1 inlet valve (TM 1-1520-238-23).



**12-48. ENG 1 ANTI ICE INDICATOR ON PILOT CAUTION/WARNING PANEL - LIGHTS  
(ENG INLET ON/OFF SWITCH ON, ENGINES RUNNING) (cont)**

12-48

6. Check for open between P954-1 and P1087-A8.  
**Does open exist?**
- |     |               |
|-----|---------------|
| YES | Go to step 8. |
| NO  | Go to step 7. |
7. With relay (A337)K1-1 removed, check for open between (A337)XK1-1-X1 and J1-A8.  
**Does open exist?**
- |     |   |
|-----|---|
| YES | Repair open wire.<br>Go to paragraph 12-25.           |
| NO  | Replace engine anti-ice relay box (TM 1-1520-238-23). |
8. Check for open between P954-1 and P21-37.  
**Does open exist?**
- |     |   |
|-----|---|
| YES | <b>(ABY)</b> Repair open wire.<br>Go to paragraph 12-25.<br><b>(ABZ)</b> Replace wire harness (TM 1-1520-238-23). |
| NO  | Repair open wire between: J449-A1 and J21-37, P449-A1 and P1087-A8.<br>Go to paragraph 12-25.                     |
9. With relay (A337)K1-1 installed and relay (A337)K1-5/6 removed, apply heat to thermal switch. Allow a minute for switch to heat. On pilot **ANTI ICE** panel, set **ENG INLET ON/OFF** switch to **ON**. Check for 28 VDC at (A337)XK1-5/6-D1.  
**Is voltage present?**
- |     |                |
|-----|----------------|
| YES | Go to step 10. |
| NO  | Go to step 11. |
10. With relay (A337)K1-5/6 removed, check for continuity between relay (A337): K1-5/6-D1 and K1-5/6-D2.  
**Does continuity exist?**
- |     |  |
|-----|--|
| YES | Replace relay (A337)K1-5/6 (TM 1-1520-238-23).   |
| NO  | Replace engine 1 NGB fairing (TM 1-1520-238-23). |
11. Check for open between (A337)XK1-1-X2 and ground.  
**Does open exist?**
- |     |  |
|-----|--|
| YES | Go to step 12.                               |
| NO  | Replace relay (A337)K1-1 (TM 1-1520-238-23). |
12. Check for open between P1087-A10 and ground.  
**Does open exist?**
- |     |  |
|-----|--|
| YES | Repair open wire between: P1087-A10 and GS572-C, TB1-3-L and ground.<br>Go to paragraph 12-25. |
| NO  | Go to step 13.   |
13. Check for open between: (A337)XK1-1-X2 and TB1-3-C, TB1-3-F and TB1-3-G, TB1-3-K and J1087-A10.  
**Does open exist?**
- |     |   |
|-----|---|
| YES | Repair open wire between P1087-A10 and GS572-C.<br>Go to paragraph 12-25. |
| NO  | Replace engine anti-ice relay box (TM 1-1520-238-23).                     |

END OF TASK

**12-49. ENG 2 ANTI ICE INDICATOR ON PILOT CAUTION/WARNING PANEL - LIGHTS  
(ENG INLET ON/OFF SWITCH ON, ENGINES RUNNING)**

**12-49**

**Tools:**

<u>Nomenclature</u>	<u>Part Number</u>
Tool Kit, Electrical Repairer's	SC518099CLA06
Extractor, Relay	CTJ-RO6
Heater, Gun Type Electric	MIL-H-45193
Multimeter, Digital	AN/PSM-45

**Personnel Required:**

68X Armament/Electrical Systems Repairer  
One person to assist

**References:**

TM 1-1520-238-23

**Equipment Conditions:**

<u>Ref</u>	<u>Condition</u>
TM 1-1520-238-23	Access provisions - L325, T250L, T250R, T290L and T290R doors opened

**WARNING**

- Turn off power before detaching or attaching wires and connectors. High current 28 VDC or 115 VAC is present. Failure to do so could result in death or serious injury.
- When using heater gun, avoid contact with skin. Heater gun can cause serious burns and start fires. Wear protective equipment. Avoid touching heated parts. If burns occur, get medical help immediately.

1. Detach P953. Remove engine 2 thermal switch. Attach P953 to thermal switch. With relay (A337)K1-2 removed, direct heat from heat gun onto thermal switch. Allow a minute for switch to heat. On pilot **ANTI ICE** panel, set **ENG INLET ON/OFF** switch to **ON**. Check for 28 VDC at (A337)XK1-2-X1.

**Is voltage present?**

- |     |               |
|-----|---------------|
| YES | Go to step 9. |
| NO  | Go to step 2. |

2. Apply heat to thermal switch while checking for open between pins S126-1 and S126-2. Allow a minute for switch to heat.

**Does open exist?**

- |     |   |
|-----|---|
| YES | Replace engine 2 thermal switch (TM 1-1520-238-23). |
| NO  | Go to step 3.                                       |

3. Check for 28 VDC at P953-2.

**Is voltage present?**

- |     |               |
|-----|---------------|
| YES | Go to step 5. |
| NO  | Go to step 4. |

4. Check for open between P953-2 and P22-42.

**Does open exist?**

- |     |  |
|-----|--|
| YES | <b>(ABY)</b> Repair open wire. Go to paragraph 12-25.<br><b>(ABZ)</b> Replace wire harness (TM 1-1520-238-23). |
| NO  | Repair open wire between: P438-A19 and J22-42. (A402): J15-A19 and TB2-14-A. Go to paragraph 12-25.            |

5. With relay (A337)K1-2 removed, check for open between (A337)XK1-2-X1 and P953-1.

**Does open exist?**

- |     |  |
|-----|--|
| YES | Go to step 6.                                    |
| NO  | Replace engine 2 inlet valve (TM 1-1520-238-23). |

**12-49. ENG 2 ANTI ICE INDICATOR ON PILOT CAUTION/WARNING PANEL - LIGHTS  
(ENG INLET ON/OFF SWITCH ON, ENGINES RUNNING) (cont)**

12-49

6. Check for open between P953-1 and P1087-A5.  
**Does open exist?**
- |     |               |
|-----|---------------|
| YES | Go to step 8. |
| NO  | Go to step 7. |
7. With relay (A337)K1-2 removed, check for open between (A337)XK1-2-X1 and J1-A5.  
**Does open exist?**
- |     |   |
|-----|---|
| YES | Repair open wire.<br>Go to paragraph 12-25.           |
| NO  | Replace engine anti-ice relay box (TM 1-1520-238-23). |
8. Check for open between P953-1 and P22-37.  
**Does open exist?**
- |     |   |
|-----|---|
| YES | <b>(ABY)</b> Repair open wire.<br>Go to paragraph 12-25.<br><b>(ABZ)</b> Replace wire harness (TM 1-1520-238-23). |
| NO  | Repair open wire between: P456-A14 and J22-37, J456-A14 and P1087-A5.<br>Go to paragraph 12-25.                   |
9. With relay (A337)K1-2 installed and relay (A337)K1-5/6 removed, apply heat to thermal switch. Allow a minute for switch to heat. On pilot **ANTI ICE** panel, set **ENG INLET ON/OFF** switch to **ON**. Check for 28 VDC at (A337)XK1-5/6-C1.  
**Is voltage present?**
- |     |                |
|-----|----------------|
| YES | Go to step 10. |
| NO  | Go to step 11. |
10. With relay (A337)K1-5/6 removed, check for continuity between relay (A337): K1-5/6-C1 and K1-5/6-C2.  
**Does continuity exist?**
- |     |  |
|-----|--|
| YES | Replace relay (A337)K1-5/6 (TM 1-1520-238-23).   |
| NO  | Replace engine 2 NGB fairing (TM 1-1520-238-23). |
11. Check for open between (A337)XK1-2-X2 and ground.  
**Does open exist?**
- |     |  |
|-----|--|
| YES | Go to step 12.                               |
| NO  | Replace relay (A337)K1-2 (TM 1-1520-238-23). |
12. Check for open between P1087-A10 and ground.  
**Does open exist?**
- |     |  |
|-----|--|
| YES | Repair open wire between: P1087-A10 and GS572-C, TB1-3-L and ground.<br>Go to paragraph 12-25. |
| NO  | Go to step 13.   |
13. Check for open between: (A337)XK1-2-X2 and TB1-3-D, TB1-3-F and TB1-3-G, TB1-3-K and J1087-A10.  
**Does open exist?**
- |     |   |
|-----|---|
| YES | Repair open wire between P1087-A10 and GS572-C.<br>Go to paragraph 12-25. |
| NO  | Replace engine anti-ice relay box (TM 1-1520-238-23).                     |

END OF TASK

**12-50. ENG 1 UPPER AFT FAIRING - DOES NOT GET HOT (ENG INLET ON/OFF SWITCH ON)**

**Tools:**

<u>Nomenclature</u>	<u>Part Number</u>
Tool Kit, Electrical Repairer's	SC518099CLA06
Multimeter, Digital	AN/PSM-45

**Personnel Required:**

68X Armament/Electrical Systems Repairer  
One person to assist

**References:**

TM 1-1520-238-23

**Equipment Conditions:**

<u>Ref</u>	<u>Condition</u>
TM 1-1520-238-23	Access provisions - L200 panel removed

**WARNING**

- Turn off power before detaching or attaching wires and connectors. High current 28 VDC or 115 VAC is present. Failure to do so could result in death or serious injury.
- Do not touch engine 1 or engine 2 NGB or upper aft fairings when ENG INLET ON/OFF switch is set to ON. Heaters in these fairings can cause serious burns. If burns occur, seek medical aid.

1. Place hand near engine 1 NGB fairing.

**Is fairing hot?**

- |     |  |
|-----|--|
| YES | Go to step 2.  |
| NO  | Refer to paragraph 12-41 to troubleshoot engine 1 NGB fairing. |

2. Check for 115 VAC at (HR3):  
P2-A,  
P2-E,  
P2-C.

**Is voltage present?**

- |     |  |
|-----|--|
| YES | Replace engine 1 upper aft fairing (TM 1-1520-238-23). |
| NO  | Replace engine 1 NGB fairing (TM 1-1520-238-23).       |

END OF TASK

**12-51. ENG 2 UPPER AFT FAIRING - DOES NOT GET HOT (ENG INLET ON/OFF SWITCH ON)**

12-51

**Tools:**

<u>Nomenclature</u>	<u>Part Number</u>
Tool Kit, Electrical Repairer's	SC518099CLA06
Multimeter, Digital	AN/PSM-45

**Personnel Required:**

68X Armament/Electrical Systems Repairer  
One person to assist

**References:**

TM 1-1520-238-23

**Equipment Conditions:**

<u>Ref</u>	<u>Condition</u>
TM 1-1520-238-23	Access provisions - R200 panel removed

**WARNING**

- Turn off power before detaching or attaching wires and connectors. High current 28 VDC or 115 VAC is present. Failure to do so could result in death or serious injury.
- Do not touch engine 1 or engine 2 NGB or upper aft fairings when ENG INLET ON/OFF switch is set to ON. Heaters in these fairings can cause serious burns. If burns occur, seek medical aid.

1. Place hand near engine 2 NGB fairing.

**Is fairing hot?**

YES	Go to step 2.
NO	Refer to paragraph 12-42 to troubleshoot engine 2 NGB fairing.

2. Check for 115 VAC at (HR4):  
P2-A,  
P2-E,  
P2-C.

**Is voltage present?**

YES	Replace engine 2 upper aft fairing (TM 1-1520-238-23).
NO	Replace engine 2 NGB fairing (TM 1-1520-238-23).

END OF TASK

---

**12-52. ECS R NOSE GRBX HTR CIRCUIT BREAKER (CB211) - DOES NOT STAY CLOSED 12-52**  
**(ENG INLET ON/OFF SWITCH OFF)**

---

**Tools:**

<u>Nomenclature</u>	<u>Part Number</u>
Tool Kit, Electrical Repairer's	SC518099CLA06
Multimeter, Digital	AN/PSM-45

**Personnel Required:**

68X Armament/Electrical Systems Repairer

**References:**

TM 1-1520-238-T-6  
 TM 1-1520-238-23

**Equipment Conditions:**

<u>Ref</u>	<u>Condition</u>
TM 1-1520-238-23	Access provisions - L200 panel removed

---



**Turn off power before detaching or attaching wires and connectors. High current 28 VDC or 115 VAC is present. Failure to do so could result in death or serious injury.**

1. Detach P2. Check for short between (A402):  
 J2-q and ground,  
 J2-r and ground,  
 J2-s and ground.  
**Does short exist?**

YES	Go to step 2.
NO	Refer to TM 1-1520-238-T-6 to troubleshoot circuit protection system (ac essential bus 1 - pilot station).

2. Detach P48. Check for short between:  
 J48-G and ground,  
 J48-L and ground,  
 J48-M and ground.  
**Does short exist?**

YES	Go to step 3.
NO	Replace right NGB fairing (TM 1-1520-238-23).

3. Check for short between:  
 P450-A and ground,  
 P450-B and ground,  
 P450-C and ground.  
**Does short exist?**

YES	Repair shorted wire between: P450-A and J48-G, P450-B and J48-L, P450-C and J48-M. Go to paragraph 12-25.
NO	Repair shorted wire between (A402): J2-q and J19-A, J2-r and J19-B, J2-s and J19-C. Go to paragraph 12-25.

END OF TASK

---

**12-53. ECS R NOSE GRBX HTR CIRCUIT BREAKER (CB211) - DOES NOT STAY CLOSED  
(ENG INLET ON/OFF SWITCH ON)**

---

12-53

**Tools:**

<u>Nomenclature</u>	<u>Part Number</u>
Tool Kit, Electrical Repairer's	SC518099CLA06

**Personnel Required:**

68X Armament/Electrical Systems Repairer

**References:**

TM 1-1520-238-23

**Equipment Conditions:**

<u>Ref</u>	<u>Condition</u>
TM 1-1520-238-23	Access provisions - R200 panel removed

---

<b>WARNING</b>
----------------

**Turn off power before detaching or attaching wires and connectors. High current 28 VDC or 115 VAC is present. Failure to do so could result in death or serious injury.**

Detach (HR4)P2 and close CB211.

**Does circuit breaker stay closed?**

YES	Replace right upper aft fairing (TM 1-1520-238-23).
NO	Replace right NGB fairing (TM 1-1520-238-23).

END OF TASK

12-54. PITOT ANTI-ICE - POWER UP

12-54

**Tools:**

Nomenclature

Tool Kit, Aircraft  
Mechanic's

Part Number

SC518099CLA01

**Equipment Conditions:**

Ref

TM 1-1520-238-23

Condition

Helicopter safed  
External power application  
- Electrical  
Pitot anti-ice system  
inspection completed

**Personnel Required:**

67R Attack Helicopter Repairer

**References:**

TM 55-1520-238-23

**NOTE**

Refer to pilot station (fig. 12-59) for cockpit configuration and equipment.

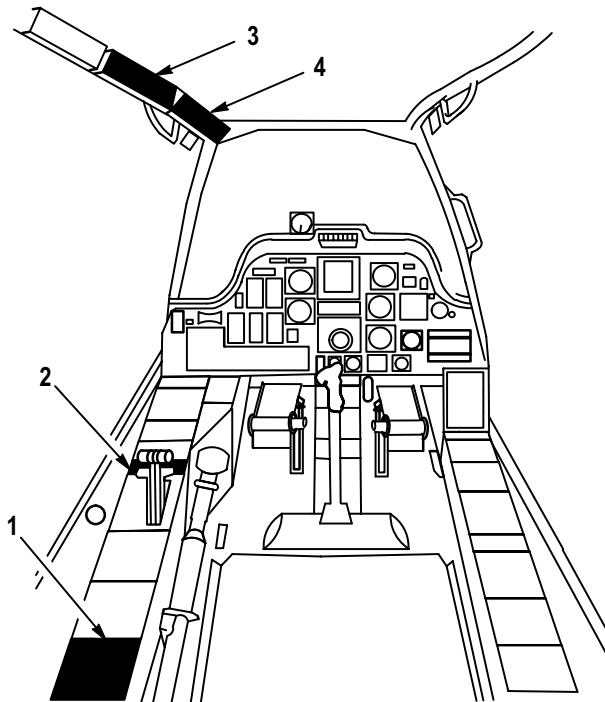

- 1. PILOT ANTI ICE PANEL
- 2. PILOT ELEC PWR PANEL
- 3. PILOT CENTER CIRCUIT BREAKER PANEL
- 4. PILOT FORWARD CIRCUIT BREAKER PANEL

M71-039

**Figure 12-59. Pilot Station**

1. On pilot **ELEC PWR** panel (fig. 12-60), set **BATT/EXT PWR** switch to **EXT PWR**.



12-54. PITOT ANTI-ICE - POWER UP (cont)

12-54

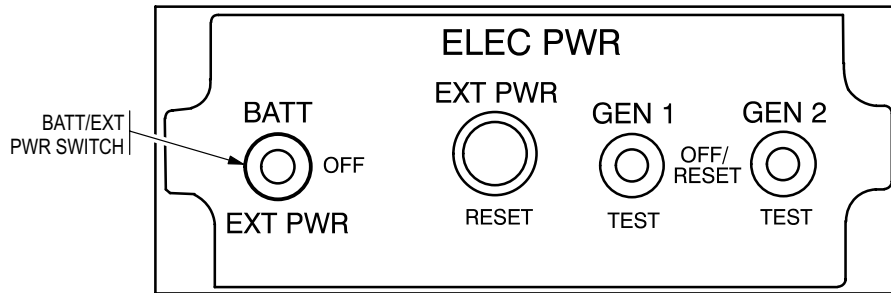

M71-040

Figure 12-60. Pilot ELEC PWR Panel

2. On pilot circuit breaker panels (fig. 12-61), check that the following circuit breakers are closed:

Circuit Breaker Panel

Circuit Breaker

Center

PITOT HTR

Forward

NAV AIR DATA DC

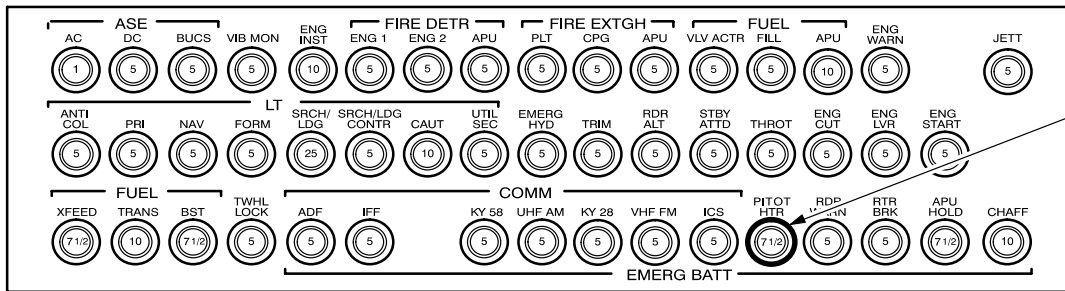

CENTER

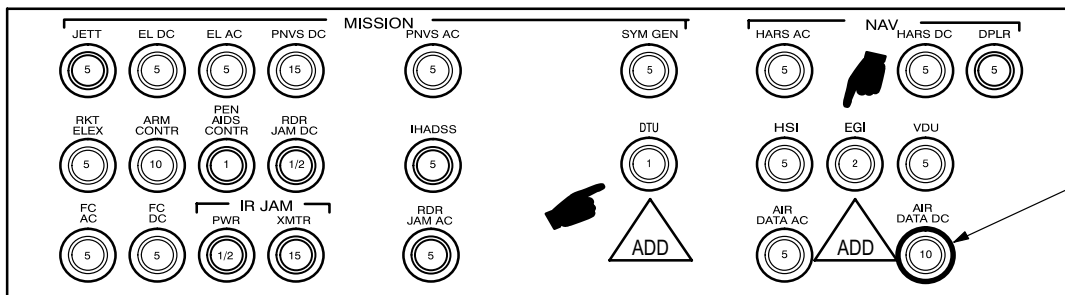

FORWARD

M71-041A

Figure 12-61. Pilot Circuit Breaker Panels

END OF TASK

**12-55. PITOT ANTI-ICE - POWER DOWN****12-55****Tools:**NomenclaturePart NumberTool Kit, Aircraft  
Mechanic's

SC518099CLA01

**References:**

TM 1-1520-238-23

**Equipment Conditions:**Ref

Paragraph 12-54

ConditionPITOT ANTI-ICE -  
POWER UP completed**Personnel Required:**

67R Attack Helicopter Repairer

**NOTE**

Refer to pilot station (fig. 12-59) for cockpit configuration and equipment.

1. On pilot circuit breaker panels (fig. 12-61), open the following circuit breakers:

Circuit Breaker Panel

Center

Forward

Circuit Breaker**PITOT HTR****NAV AIR DATA DC**

2. On pilot **ELEC PWR** panel (fig. 12-60), set **BATT/EXT PWR** switch to **OFF**.
3. Remove external power - electrical (TM 1-1520-238-23).

END OF TASK

12-56. PITOT ANTI-ICE - MAINTENANCE OPERATIONAL CHECK

12-56

**Tools:**

Nomenclature	Part Number
Tool Kit, Aircraft Mechanic's	SC518099CLA01

**References:**

TM 1-1520-238-T-4

**Equipment Conditions:**

Ref	Condition
TM 1-1520-238-T-4	Maintenance headset connected
Paragraph 12-54	PITOT ANTI-ICE - POWER UP completed

**Personnel Required:**

67R Attack Helicopter Repairer  
One person to assist

**NOTE**

- Refer to pilot station (fig. 12-59) for cockpit configuration and equipment.
- If referenced out of one paragraph or volume and into another for additional troubleshooting, upon completion of the task, return to the maintenance operational check for the original paragraph or volume.

1. Perform the maintenance operational check as follows:

Task	Result
a. On pilot <b>ANTI ICE</b> panel (fig. 12-62), check that <b>PITOT ICE DET AD SNSR</b> switch is set to <b>OFF</b> .	

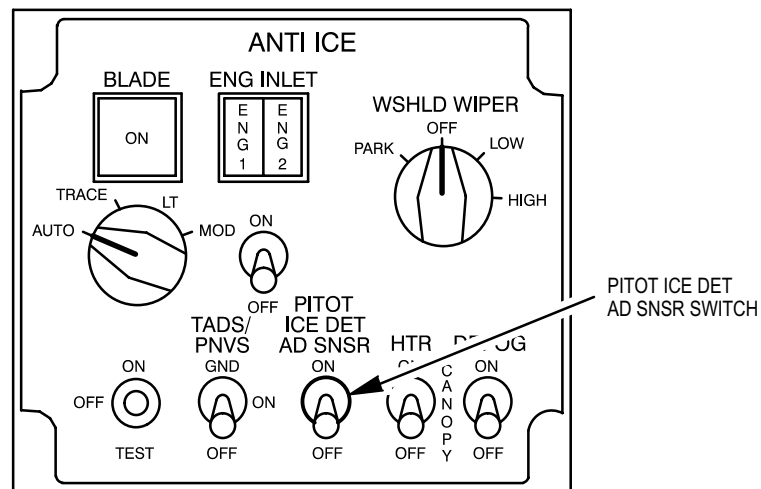

M71-043

Figure 12-62. Pilot ANTI ICE Panel

12-56. PITOT ANTI-ICE - MAINTENANCE OPERATIONAL CHECK (cont)

12-56

Task	Result
------	--------

- b. Check that covers are removed from Pitot tubes (fig. 12-63).

**CAUTION**

Remove Pitot covers to prevent heaters in the Pitot tubes from burning the covers.

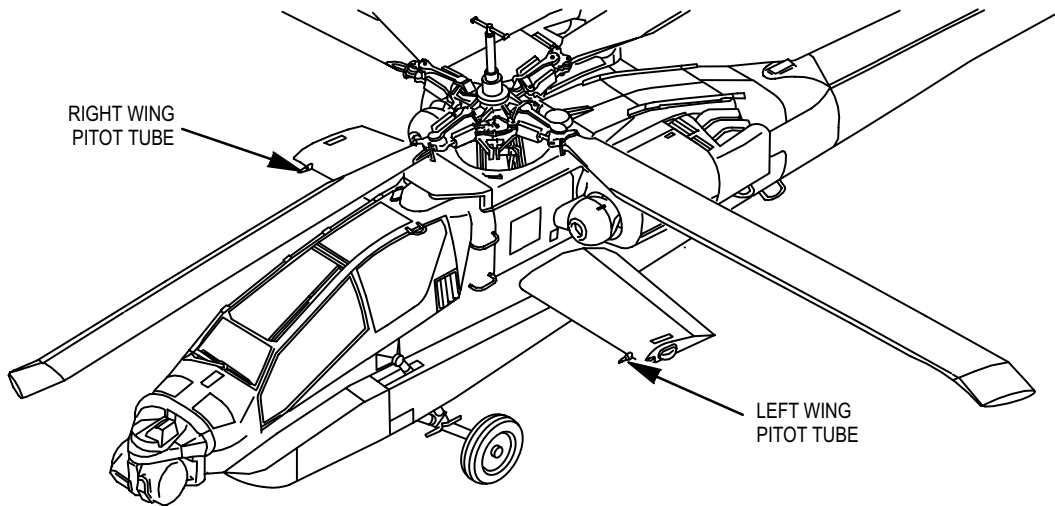

M71-044

Figure 12-63. Pitot Tubes

**WARNING**

Do not touch pitot tubes when PITOT ICE DET AD SNSR switch is set to ON. Heaters in these tubes can cause serious burns. If burns occur, seek medical aid.

- c. On pilot **ANTI ICE** panel (fig. 12-62), set **PITOT ICE DET AD SNSR** switch to **ON** for 6 seconds, then set switch to **OFF**.

If **NAV AIR DATA DC** circuit breaker does not stay closed, go to paragraph 12-58.

If **PITOT HTR** circuit breaker does not stay closed, go to paragraph 12-59.

---

**12-56. PITOT ANTI-ICE - MAINTENANCE OPERATIONAL CHECK (cont)****12-56**

---

Task	Result
d. Place hand near left wing Pitot tube. Check for warm air temperature (indicates heater operated).	If left wing Pitot tube heater does not heat, go to paragraph 12-60.
e. Place hand near right wing Pitot tube. Check for warm air temperature (indicates heater operated).	If right wing Pitot tube heater does not heat, go to paragraph 12-61.

---

2. Perform PITOT ANTI-ICE - POWER DOWN (para 12-55).
3. After Pitot tubes have cooled, install Pitot covers.
4. Disconnect maintenance headset (TM 1-1520-238-T-4).

END OF TASK

12-57. PITOT ANTI-ICE - WIRING INTERCONNECT DIAGRAM

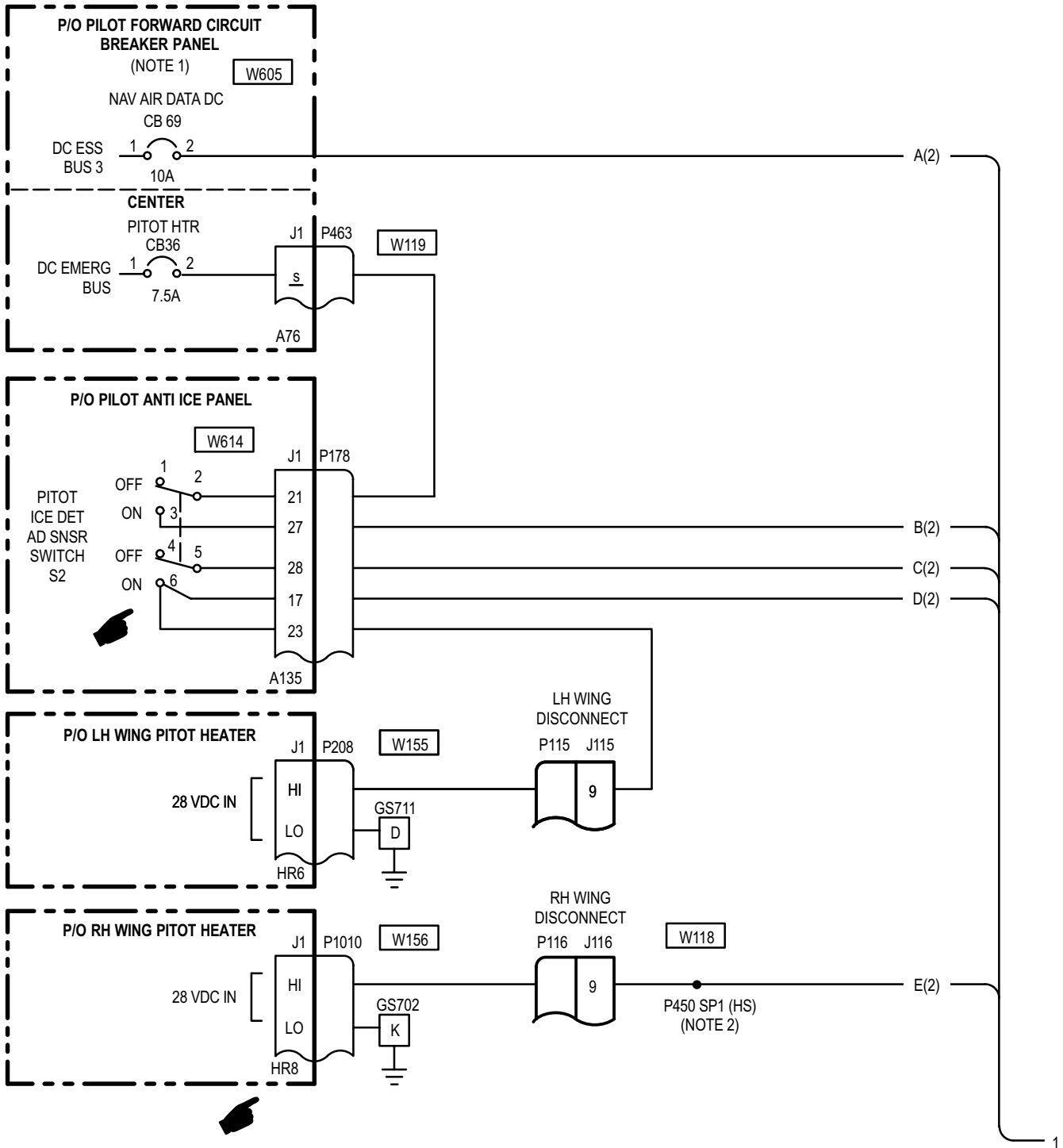

12-57. PITOT ANTI-ICE - WIRING INTERCONNECT DIAGRAM (cont) (cont)

12-57

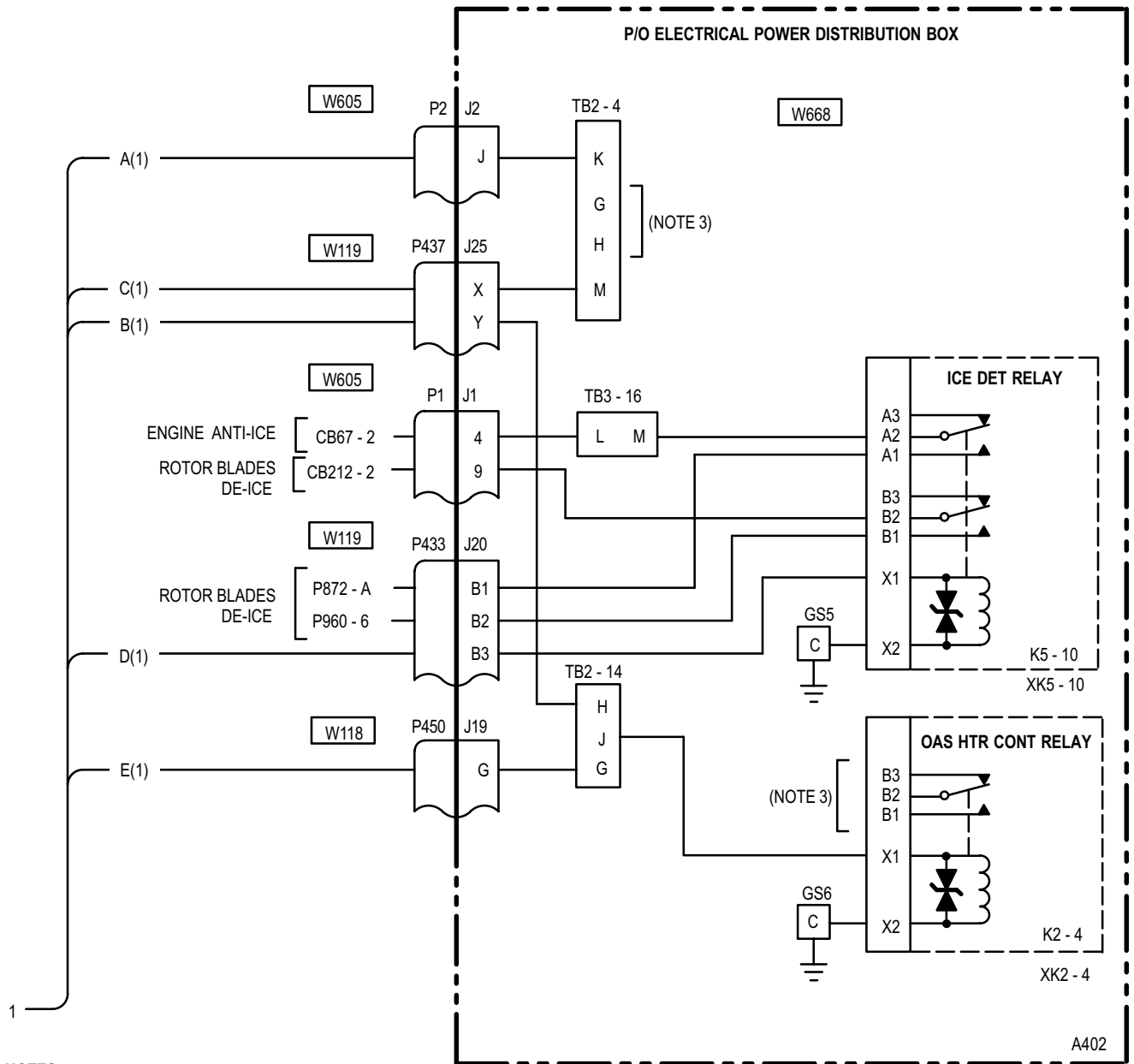

NOTES:

HIGHWAY USE: THE ALPHA CHARACTER IDENTIFIES A SPECIFIC LINE, AND THE NUMBER IN PARENTHESIS IDENTIFIES THE SHEET NUMBER WHERE THE SIGNAL TERMINATES.

1. ELECTRICAL SYSTEM (TM 1-1520-238-T-6).
2. HS DESIGNATES A HARD SPLICE WHICH MAY NOT BE DISCONNECTED.  
M DESIGNATES A SOFT SPLICE WHICH MAY BE DISCONNECTED FOR A WIRING CHECK.
3. FIRE CONTROL SYSTEM - AIR DATA SUBSYSTEM (TM 9-1230-476-20-2).

**12-58. NAV AIR DATA DC CIRCUIT BREAKER (CB69) - DOES NOT STAY CLOSED  
(PITOT ICE DET AD SNSR SWITCH ON)**

**Tools:**

<u>Nomenclature</u>	<u>Part Number</u>
Tool Kit, Electrical Repairer's	SC518099CLA06
Multimeter, Digital	AN/PSM-45
Extractor, Relay	CTJ-RO6

**Personnel Required:**

68X Armament/Electrical Systems Repairer  
One person to assist

**References:**

TM 1-1520-238-T-6  
TM 55-1520-238-23



**Turn off power before detaching or attaching wires and connectors. High current 28 VDC or 115 VAC is present. Failure to do so could result in death or serious injury.**

1. On pilot **ANTI ICE** panel, set **PITOT ICE DET AD SNSR** switch to **OFF**.

**Does circuit breaker stay closed?**

- YES Go to step 2.
- NO Go to step 5.

2. Detach P433. Check for short between P178-17 and ground.

**Does short exist?**

- YES Repair shorted wire between P178-17 and P433-B3. Go to paragraph 12-56.
- NO Go to step 3.

3. Check for short between (A135)J1-17 and ground.

**Does short exist?**

- YES Replace pilot **ANTI ICE** panel (TM 55-1520-238-23).
- NO Go to step 4.

4. With relay (A402)K5-10 removed, check for short between (A402)XK5-10-X1 and ground.

**Does short exist?**

- YES Repair shorted wire between XK5-10-X1 and J20-B3. Go to paragraph 12-56.
- NO Replace relay (A402)K5-10 (TM 55-1520-238-23).

5. Detach P208. On pilot **ANTI ICE** panel, set **PITOT ICE DET AD SNSR** switch to **ON**. Check for short between (A402)J2-J and ground.

**Does short exist?**

- YES Go to step 6.
- NO Go to step 7.

6. Detach P178. Check for short between (A135): J1-28 and ground, J1-23 and ground, J1-17 and ground.

**Does short exist?**

- YES Replace pilot **ANTI ICE** panel (TM 55-1520-238-23).
- NO Repair shorted wire between: P437-X and P178-28, P178-23 and J115-9, P115-9 and P208-HI. (A402): J2-J and TB2-4-K, TB2-4-M and J25-X. Go to paragraph 12-56.

7. Check for 2.5 ±0.3 ohms resistance between (HR6): J1-1 and J1-2.

**Is resistance present?**

- YES Refer to TM 1-1520-238-T-6 to troubleshoot circuit protection system (dc essential bus 3 -pilot station).
- NO Replace LH wing Pitot heater (TM 55-1520-238-23).

END OF TASK



**12-59. PITOT HTR CIRCUIT BREAKER (CB36) - DOES NOT STAY CLOSED**

**12-59**

**Tools:**

<u>Nomenclature</u>	<u>Part Number</u>
Tool Kit, Electrical Repairer's	SC518099CLA06
Multimeter, Digital	AN/PSM-45
Extractor, Relay	CTJ-RO6

**Personnel Required:**

68X Armament/Electrical Systems Repairer  
One person to assist

**References:**

TM 1-1520-238-T-6  
TM 55-1520-238-23



**Turn off power before detaching or attaching wires and connectors. High current 28 VDC or 115 VAC is present. Failure to do so could result in death or serious injury.**

1. With **PITOT HTR** circuit breaker (CB36) open, check for short between (A76)J1-S and ground.  
**Does short exist?**

YES	Refer to TM 1-1520-238-T-6 to troubleshoot circuit protection system (dc emergency bus - pilot station).
NO	Go to step 2.

2. Detach P178. Check for short between: P463-s and ground, P437-Y and ground.  
**Does short exist?**

YES	Repair shorted wire between: P463-s and P178-21, P437-Y and P178-27. Go to paragraph 12-56.
NO	Go to step 3.

3. Set **PITOT ICE DET AD SNSR** switch to **ON**. Check for short between (A135)J1-21 and ground.

**Does short exist?**

YES	Replace pilot <b>ANTI ICE</b> panel (TM 55-1520-238-23).
NO	Go to step 4.

4. Detach P450. Check for short between (A402)J25-Y and ground.

**Does short exist?**

YES	Go to step 5.
NO	Go to step 6.

5. With relay (A402)K2-4 removed, check for 320 ±20 ohms between (A402): K2-4-X1 and K2-4-X2.

**Is resistance present?**

YES	Repair shorted wire between (A402): TB2-14-G and J19-G, TB2-14-H and J25-Y, TB2-14-J and XK2-4-X1. Go to paragraph 12-56.
NO	Replace relay (A402)K2-4 (TM 55-1520-238-23).

6. Detach P1010. Check for short between P450-G and ground.

**Does short exist?**

YES	Repair shorted wire between: P450-G and P450 SP1, P450 SP1 and J116-9, P116-9 and P1010-H1. Go to paragraph 12-56.
NO	Replace right wing Pitot tube (TM 55-1520-238-23).

END OF TASK

12-60. LEFT WING PITOT TUBE HEATER - DOES NOT HEAT

12-60

**Tools:**

<u>Nomenclature</u>	<u>Part Number</u>
Tool Kit, Electrical Repairer's	SC518099CLA06
Multimeter, Digital	AN/PSM-45

**Personnel Required:**

68X Armament/Electrical Systems Repairer  
One person to assist

**References:**

TM 1-1520-238-T-6  
TM 55-1520-238-23



Turn off power before detaching or attaching wires and connectors. High current 28 VDC or 115 VAC is present. Failure to do so could result in death or serious injury.



Remove Pitot cover to prevent heaters in the Pitot tubes from burning the cover.

1. Check for 28 VDC at P178-28.  
**Is voltage present?**

YES Go to step 3.  
NO Go to step 2.

2. Check for 28 VDC at P2-J.  
**Is voltage present?**

YES Repair open wire between: P178-28 and P437-X. (A402): J25-X and J2-J. Go to paragraph 12-56.  
NO Refer to TM 1-1520-238-T-6 to troubleshoot circuit protection system (dc essential bus 3 - pilot station).

3. On pilot **ANTI ICE** panel, set **PITOT ICE DET AD SNSR** switch to **ON**. Check for open between (A135): J1-23 and J1-28.

**Does open exist?**

YES Replace pilot **ANTI ICE** panel (TM 55-1520-238-23).  
NO Go to step 4.

4. Check for 28 VDC between P208-HI and P208-LO.

**Is voltage present?**

YES Replace left wing Pitot tube (TM 55-1520-238-23).  
NO Repair open wire between: P208-HI and P178-23, P208-LO and ground. Go to paragraph 12-56.

END OF TASK

12-61. RIGHT WING PITOT TUBE HEATER - DOES NOT HEAT

12-61

**Tools:**

Nomenclature	Part Number
Tool Kit, Electrical Repairer's	SC518099CLA06
Multimeter, Digital	AN/PSM-45

**Personnel Required:**

68X Armament/Electrical Systems Repairer  
One person to assist

**References:**

TM 1-1520-238-T-6  
TM 55-1520-238-23



Turn off power before detaching or attaching wires and connectors. High current 28 VDC or 115 VAC is present. Failure to do so could result in death or serious injury.



Remove Pitot cover to prevent heaters in the Pitot tubes from burning the cover.

1. Check for 28 VDC at P178-21.

**Is voltage present?**

YES Go to step 3.

NO Go to step 2.

2. On pilot forward circuit breaker panel, check for 28 VDC at (A76)J1-s.

**Is voltage present?**

YES Repair open wire between P178-21 and P463-s.  
Go to paragraph 12-56.

NO Refer to TM 1-1520-238-T-6 to troubleshoot circuit protection system (dc emergency bus - pilot station).

3. On pilot **ANTI ICE** panel, set **PITOT ICE DET AD SNSR** switch to **ON**. Check for open between (A135): J1-21 and J1-27.

**Does open exist?**

YES Replace pilot **ANTI ICE** panel (TM 55-1520-238-23).

NO Go to step 4.

4. Check for 28 VDC between P1010-HI and P1010-LO.

**Is voltage present?**

YES Replace right wing Pitot tube (TM 55-1520-238-23).

NO Repair open wire between: P1010-HI and P178-27, P1010-LO and ground.  
Go to paragraph 12-56.

END OF TASK

12-62. ROTOR BLADES DE-ICE - MAINTENANCE OPERATIONAL CHECK

**Tools:**

Nomenclature	Part Number
Tool Kit, Aircraft Mechanic's	SC518099CLA01
Tool Kit, Electrical Repairer's	SC518099CLA06

**Equipment Conditions:**

Ref	Condition
TM 55-1520-238-23	Rotor blades de-ice system - inspection completed
TM 1-1520-238-T-4	APU operating Maintenance headset connected

**Personnel Required:**

- 67R Attack Helicopter Repairer
- 68X Armament/Electrical Systems Repairer

**References:**

- TM 1-1520-238-T-1
- TM 1-1520-238-T-4
- TM 55-1520-238-23

**NOTE**

- If TB 1-1520-238-20-62 (Deactivation of Main Rotor and Tail Rotor Blade De-Ice Capability) is complied with, this task is not required.
- Refer to pilot station (fig. 12-64) for cockpit configuration and equipment.
- If referenced out of one paragraph or volume and into another for additional troubleshooting, upon completion of the task, return to the maintenance operational check for the original paragraph or volume.

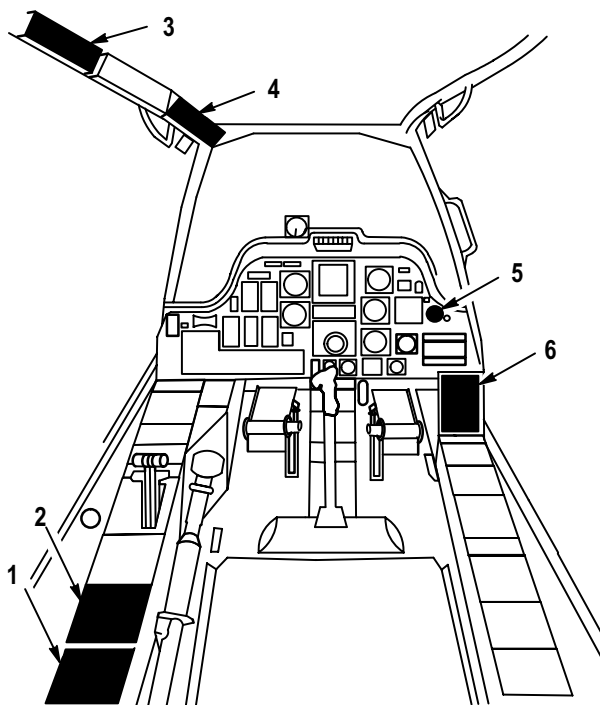

1. PILOT ANTI ICE PANEL
2. PILOT EXT LT / INTR LT PANEL
3. PILOT AFT CIRCUIT BREAKER PANEL
4. PILOT FORWARD CIRCUIT BREAKER PANEL
5. PILOT ICING SEVERITY METER
6. PILOT CAUTION/WARNING PANEL

Figure 12-64. Pilot Station

M71-055



- Do not perform rotor blades de-ice checks at less than 10-minute intervals, or when outside air temperature is above 77° F (25° C). Failure to observe precaution could cause damage to components.
- Do not operate blade de-ice system with rotor blade erosion strips installed. Failure to do so could result in damage to rotor blades.

**NOTE**

Blade de-ice heaters will not operate when OAT is above 39° F (4° C).

1. Perform the maintenance operational check as follows:

Task	Result
a. Perform De-Ice FD/LS check (TM 1-1520-238-T-1).	

**NOTE**

If a discrepancy is noted during the FD/LS check, perform corrective action indicated in TM 1-1520-238-T-1. If the discrepancy still exists after performing the corrective action required, refer to the following listed failure symptoms and perform troubleshooting.

If **TAIL ROTOR HEATER NO-GO TAIL ROTOR** appears on heads out display (HOD) and no fault is found during FD/LS check, go to paragraph 12-68 and perform troubleshooting.

If **MAIN ROTOR HEATER NO-GO MAIN ROTOR** appears on HOD and no fault is found during FD/LS check, go to paragraph 12-69 and perform troubleshooting.

If **RTR BLADE PWR CONTROLLER NO-GO RH XMSN BAY (ACY), RTR BLADE PWR CONT (ACZ), or RTR BLADE DISTR DE-ICE NO-GO MAIN RTR MAST** appears on HOD and no fault is found during FD/LS check, go to paragraph 12-70 and perform troubleshooting.

12-62. ROTOR BLADES DE-ICE - MAINTENANCE OPERATIONAL CHECK (cont)

12-62

Task	Result
<p>b. On pilot aft circuit breaker panel (fig. 12-65), close the following circuit breakers:</p>	<p>If <b>ICE DETECTOR CONTROLLER NO-GO FIREWALL LH SIDE</b> appears on HOD and no fault is found during FD/LS check, go to paragraph 12-78 and perform troubleshooting.</p>
<p><u>Circuit Breaker</u></p>	<p>If <b>ICE DETECTOR SENSOR NO-GO ENG INLET LH SIDE (ACY)</b> or <b>ICE DETECTOR SENSOR NO-GO DOGHOUSE FAIRING (ACZ)</b> appears on HOD and no fault is found during FD/LS check, go to paragraph 12-79 and perform troubleshooting.</p>
<p><b>ECS BLADE DE-ICE</b>  <b>ECS BLADE DE-ICE CONTR</b>  <b>ECS ICE DET HTR</b>  <b>ECS ENG ANTI-ICE</b>  <b>ECS ICE DET</b></p>	<p>If <b>ECS BLADE DE-ICE CONTR</b> circuit breaker does not stay closed, go to paragraph 12-65.</p>
<p>c. On pilot <b>ANTI ICE</b> panel (fig. 12-66), check that <b>ON/OFF/TEST</b> switch is set to <b>OFF</b> and set <b>AUTO/TRACE/LT/MOD</b> switch is set to <b>AUTO</b>.</p>	<p>If <b>ECS BLADE DE-ICE</b> circuit breaker does not stay closed, go to paragraph 12-64.</p>
<p>d. Momentarily set <b>ON/OFF/TEST</b> switch to <b>TEST</b>.</p>	<p>If <b>ECS ICE DET</b> circuit breaker does not stay closed, go to paragraph 12-67.</p>
<p>e. Set <b>ON/OFF/TEST</b> switch to <b>ON</b>.</p>	<p>If <b>ECS ICE DET HTR</b> circuit breaker does not stay closed, go to paragraph 12-83.</p>
	<p>If <b>BLADE ANTI ICE FAIL</b> indicator on pilot caution/warning panel (fig. 12-67) is lighted, go to paragraph 12-72.</p>
	<p>If <b>ENG ICE</b> indicator on pilot caution/warning panel is lighted, go to paragraph 12-77.</p>
	<p>If <b>ECS BLADE DE-ICE CONTR</b> circuit breaker does not stay closed, go to paragraph 12-65.</p>
	<p>If <b>ECS BLADE DE-ICE CONTR</b> circuit breaker does not stay closed, go to paragraph 12-66.</p>
	<p>If <b>BLADE</b> de-ice <b>ON</b> indicator on pilot <b>ANTI ICE</b> panel does not light, replace lamp (TM 1-1520-238-23). If lamp still does not light, go to paragraph 12-71.</p>

12-62. ROTOR BLADES DE-ICE - MAINTENANCE OPERATIONAL CHECK (cont)

12-62

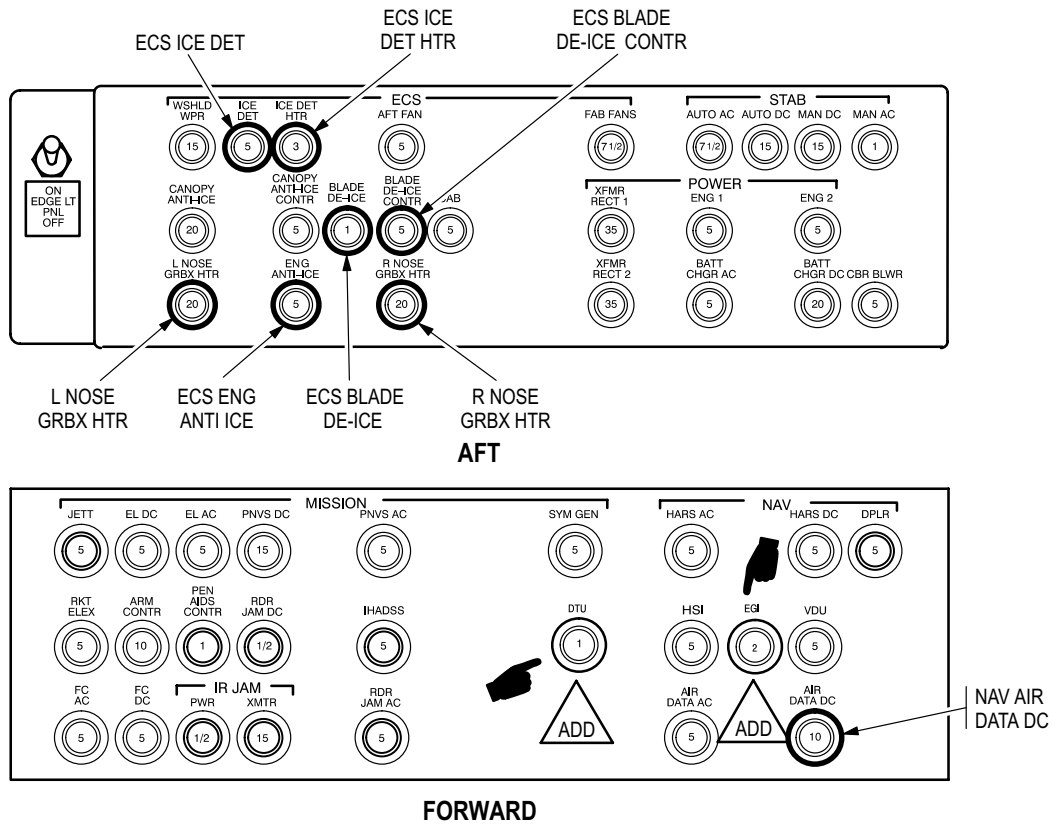

M71-056A

Figure 12-65. Pilot Circuit Breaker Panels

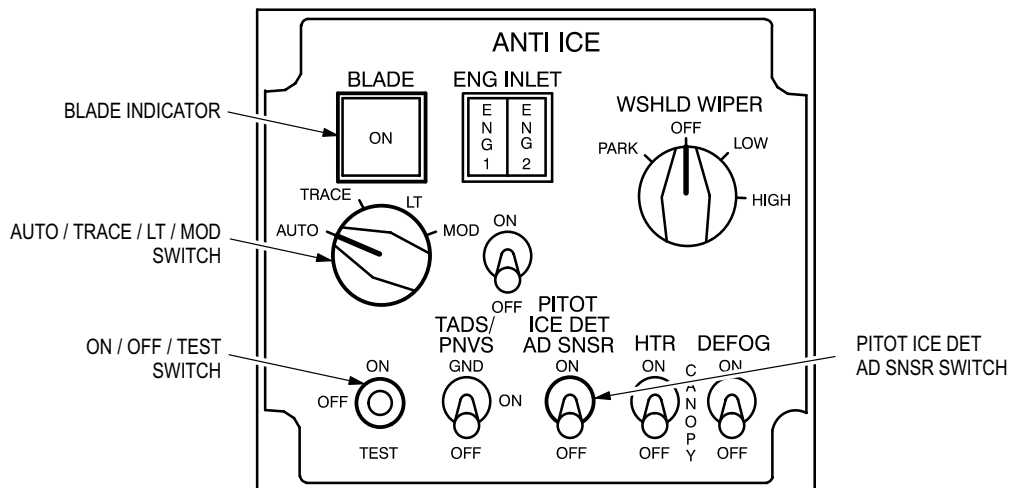

M71-057

Figure 12-66. Pilot ANTI ICE Panel

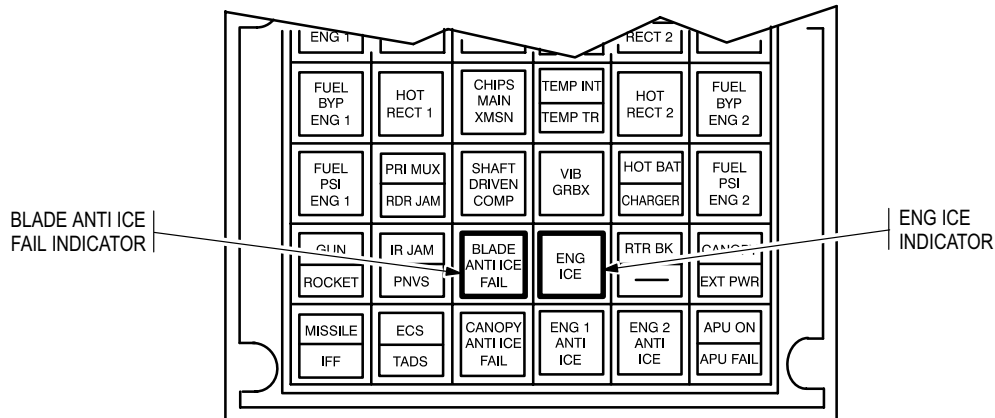

M71-058

Figure 12-67. Pilot Caution/Warning Panel

Task	Result
<p>f. On pilot <b>ANTI ICE</b> panel (fig. 12-66), set <b>AUTO/TRACE/LT/MOD</b> switch to <b>MOD</b>. On pilot aft circuit breaker panel (fig. 12-65), open <b>ECS BLADE DE-ICE CONTR</b> and <b>ECS BLADE DE-ICE</b> circuit breakers.</p>	<p>If <b>BLADE ANTI ICE FAIL</b> indicator on pilot caution/warning panel does not momentarily light, replace lamp (TM 55-1520-238-23). If lamp still does not light, go to paragraph 12-72.</p>
<p>g. Set <b>ON/OFF/TEST</b> switch to <b>OFF</b> and <b>AUTO/TRACE/LT/MOD</b> switch to <b>AUTO</b>. Close <b>ECS BLADE DE-ICE CONTR</b> and <b>ECS BLADE DE-ICE</b> circuit breakers.</p>	
<p>h. On pilot instrument panel, press <b>PRESS TO TEST</b> pushbutton next to icing severity meter (fig. 12-68).</p>	<p>If icing severity meter does not indicate <b>1.5 g/m<sup>3</sup></b>, go to paragraph 12-73.</p>

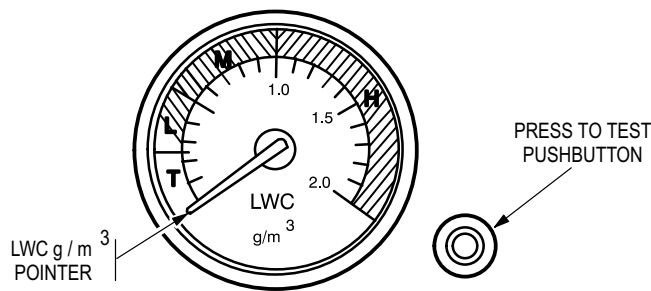

M71-059

Figure 12-68. Pilot Icing Severity Meter

- i. On pilot left console **EXT LT/INTR LT** panel (fig. 12-69), rotate **INST** control between **OFF** and **BRT**.
- If icing severity meter does not brighten, go to paragraph 12-76.



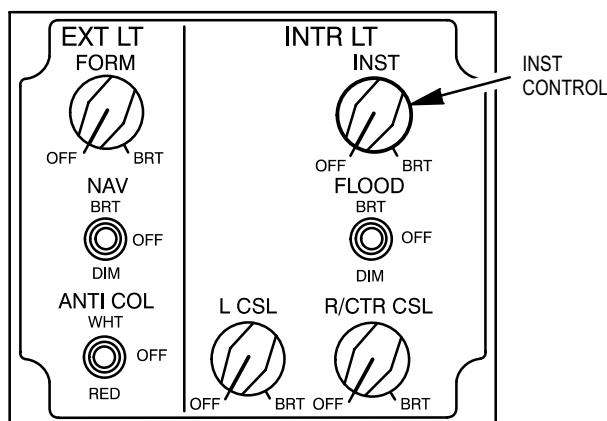

M71-060

Figure 12-69. Pilot EXT LT/INTR LT Panel

**NOTE**

Icing condition faults for the rotor blades can not be simulated for the maintenance operational check. Refer to the following results if actual icing faults occur.

Task	Result
	<p>If meter does not indicate greater than <b>0.0 g/m<sup>3</sup></b> when <b>ENG ICE</b> indicator is lighted, go to paragraph 12-74.</p> <p>If <b>ENG ICE</b> indicator does not light when meter indicates greater than <b>0.0 g/m<sup>3</sup></b>, replace lamp (TM 55-1520-238-23). If lamp still does not light, go to paragraph 12-75.</p>

**WARNING**

Turn off power before detaching or attaching wires and connectors. High current 28 VDC or 115 VAC is present. Failure to do so could result in death or serious injury.

- j. On left wing, detach connector P208. On pilot aft circuit breaker panel (fig. 12-65), open **R NOSE GRBX HTR** and **L NOSE GRBX HTR** circuit breakers. On pilot forward circuit breaker panel, close **NAV AIR DATA DC** circuit breaker. On pilot **ANTI ICE** panel (fig. 12-66), set **PITOT ICE DET AD SNSR** switch to **ON**. Check that air flows from rear of ice detector sensor, located on doghouse fairing (fig. 12-70).
- If **NAV AIR DATA DC** circuit breaker does not stay closed, go to paragraph 12-58.
- If **ECS ICE DET HTR** circuit breaker does not stay closed, go to paragraph 12-84.
- If **ECS ENG ANTI-ICE** circuit breaker does not stay closed, go to paragraph 12-80.
- If there is no airflow through the ice detector sensor, go to paragraph 12-82.

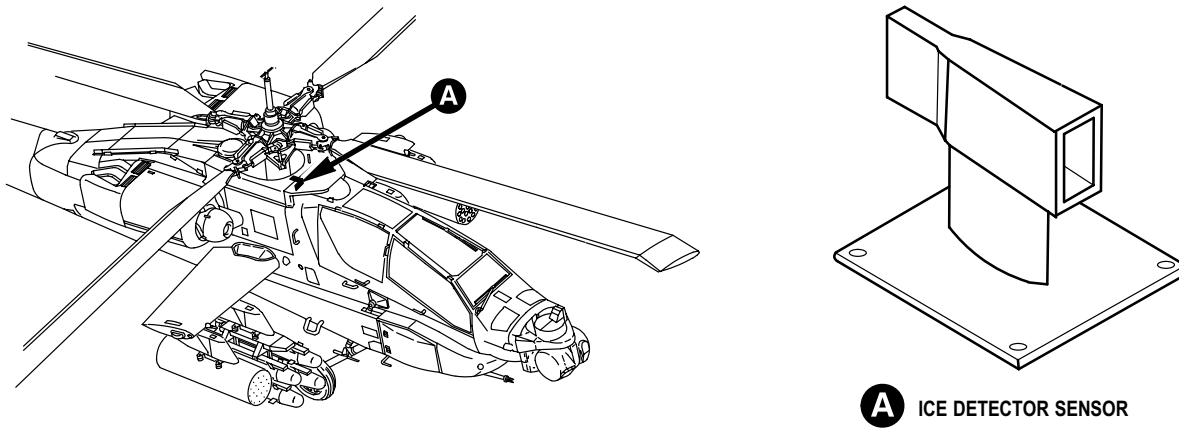

M71-062

Figure 12-70. Ice Detector Sensor Location

Task	Result
<p>k. On pilot <b>ANTI ICE</b> panel (fig. 12-66), set <b>PITOT ICE DET AD SNSR</b> switch to <b>OFF</b>. Check that air flow from ice detector sensor stops.</p> <p>l. On left wing, attach connector P208.</p>	<p>If air flow through ice detector sensor does not stop, go to paragraph 12-81.</p>

2. Shut down APU (TM 55-1520-238-23).
3. Disconnect maintenance headset (TM 1-1520-238-T-4).

END OF TASK

12-63. ROTOR BLADES DE-ICE - WIRING INTERCONNECT DIAGRAM

12-63

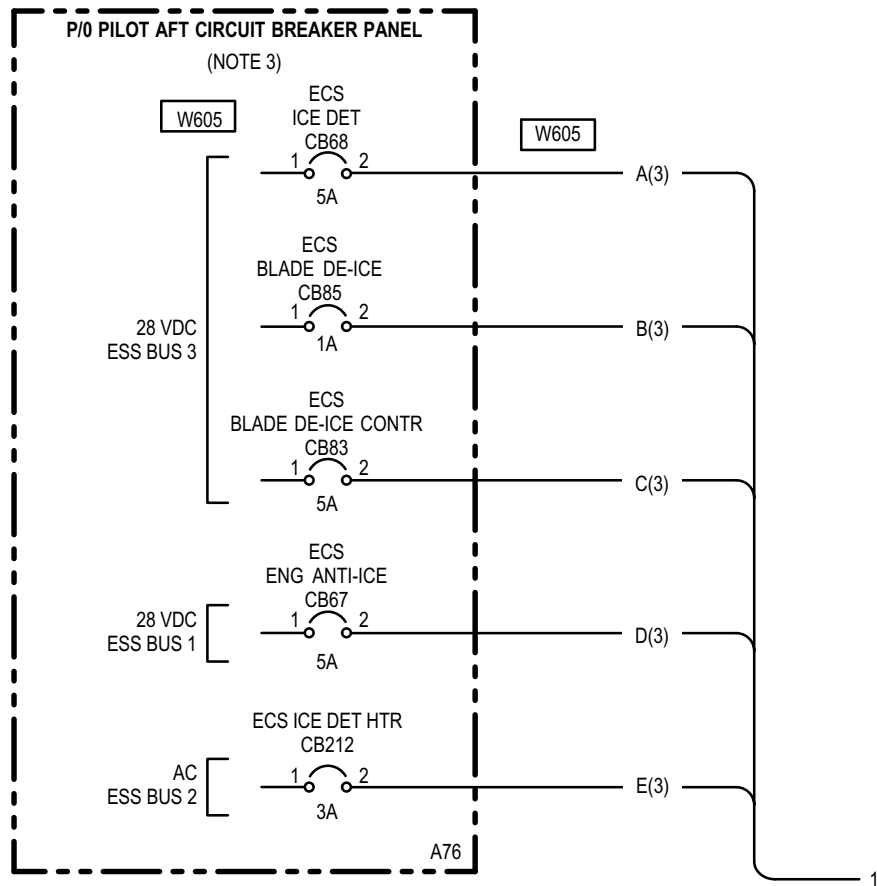

12-63. ROTOR BLADES DE-ICE - WIRING INTERCONNECT DIAGRAM (cont)

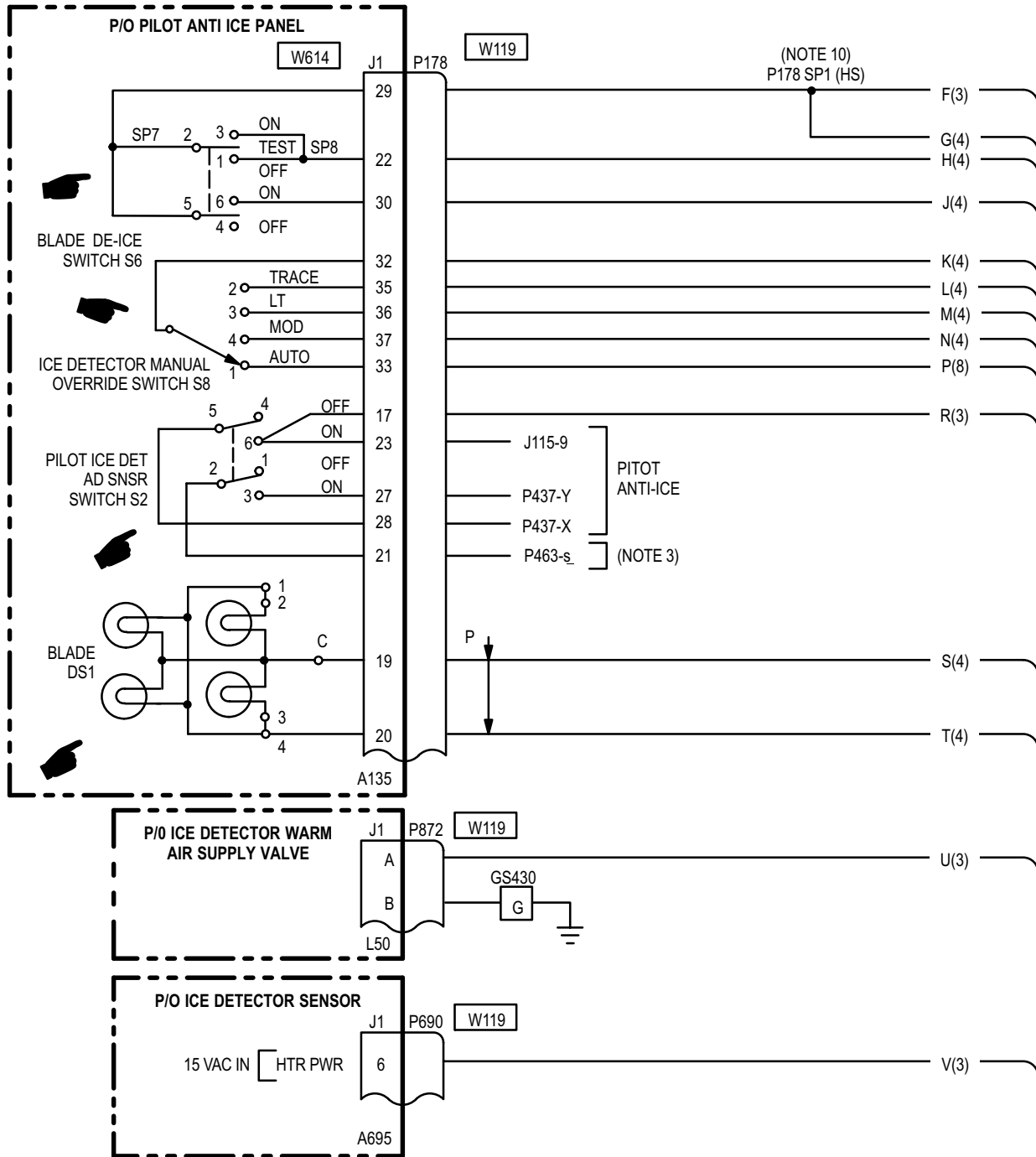

1 \_\_\_\_\_ 1

12-63. ROTOR BLADES DE-ICE - WIRING INTERCONNECT DIAGRAM (cont)

12-63

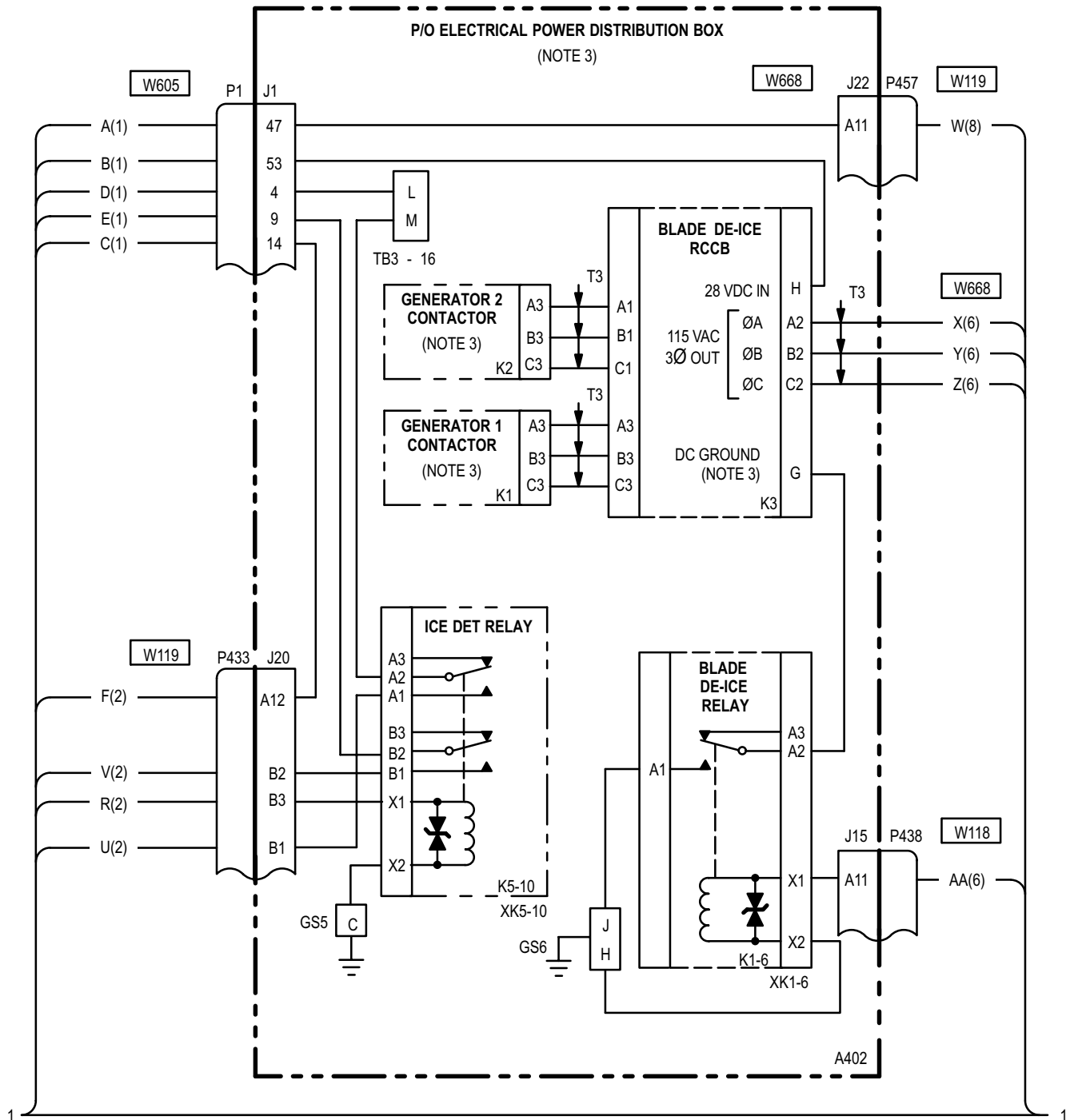

12-63. ROTOR BLADES DE-ICE - WIRING INTERCONNECT DIAGRAM (cont)

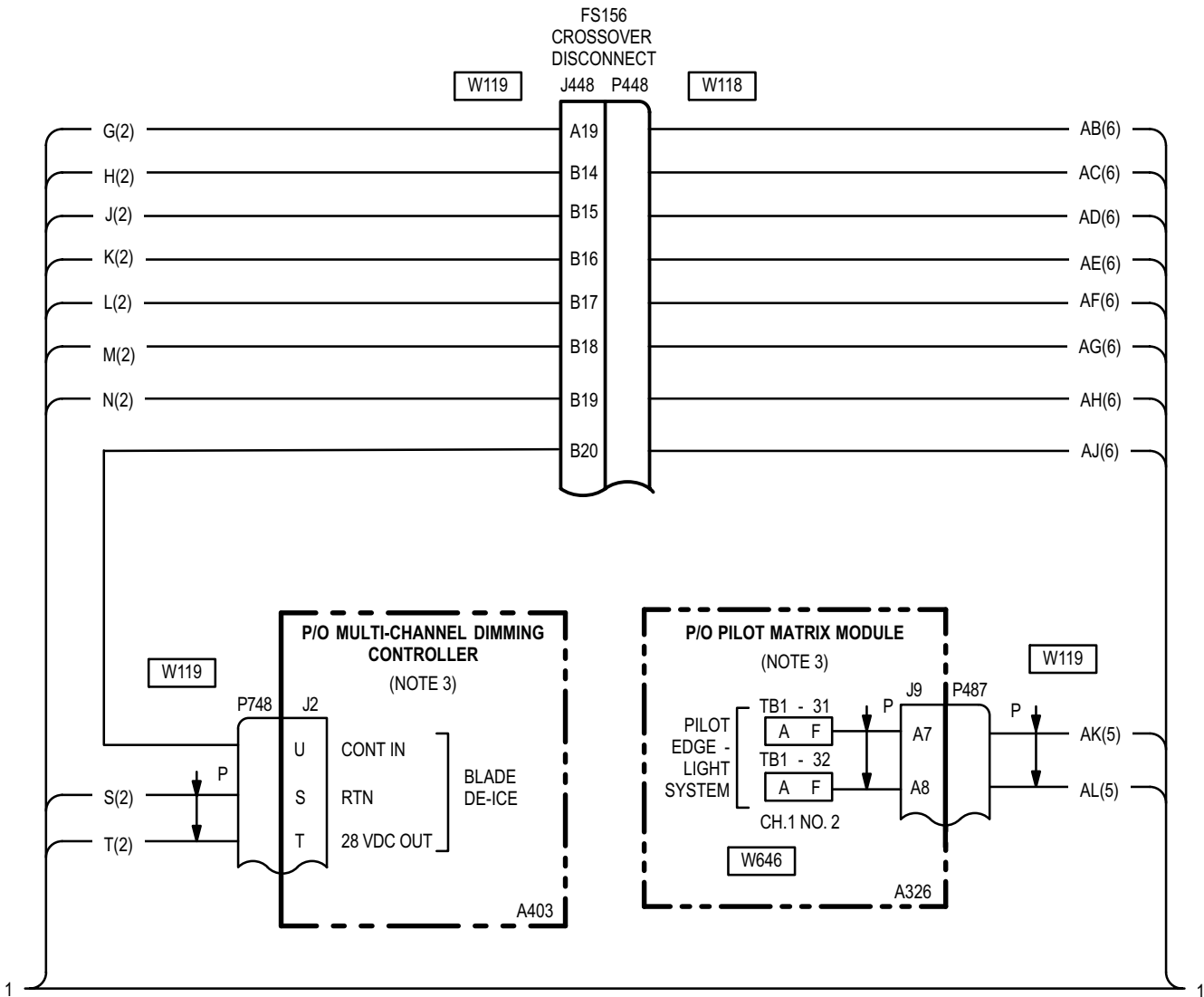

12-63. ROTOR BLADES DE-ICE - WIRING INTERCONNECT DIAGRAM (cont)

12-63

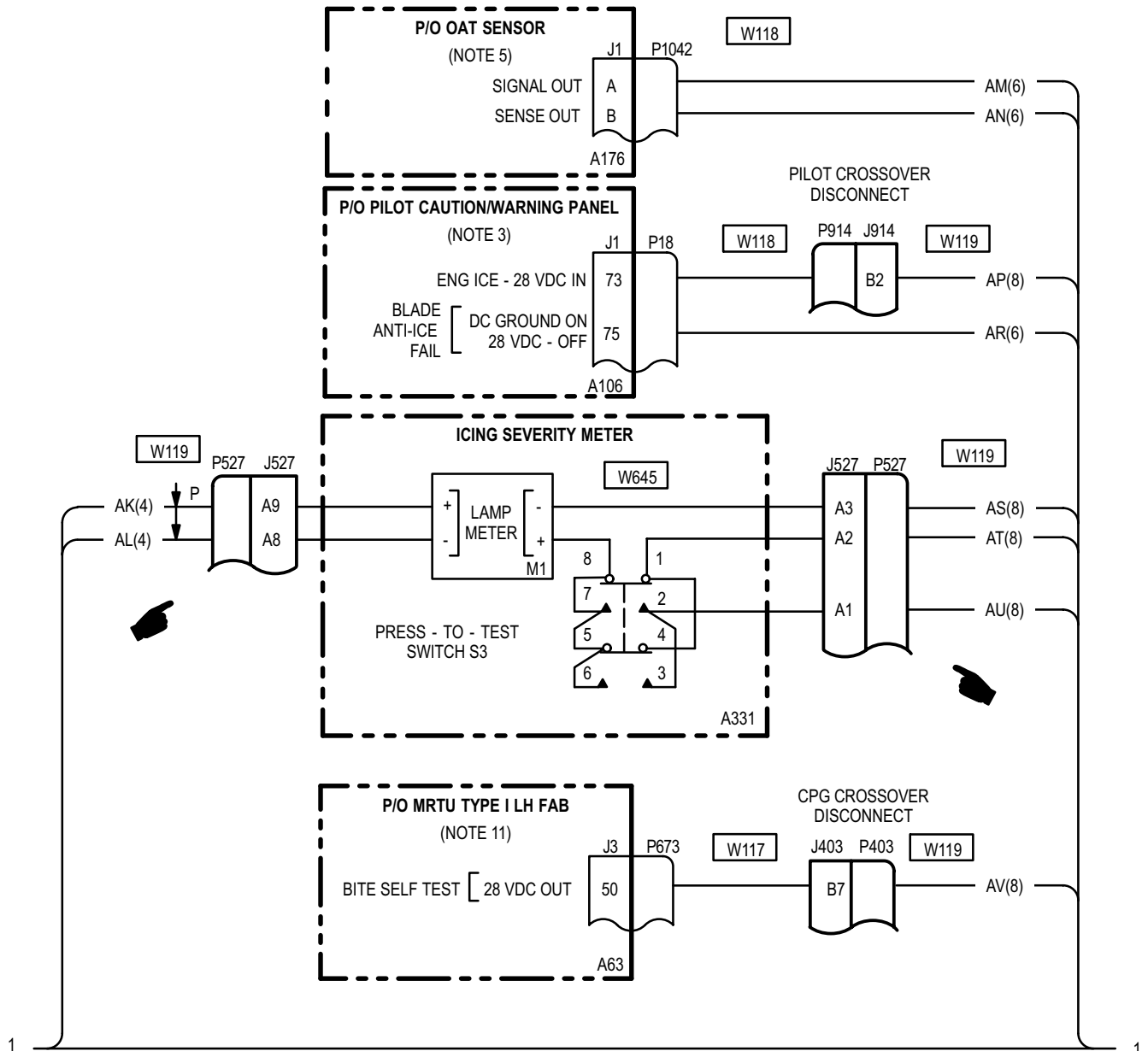

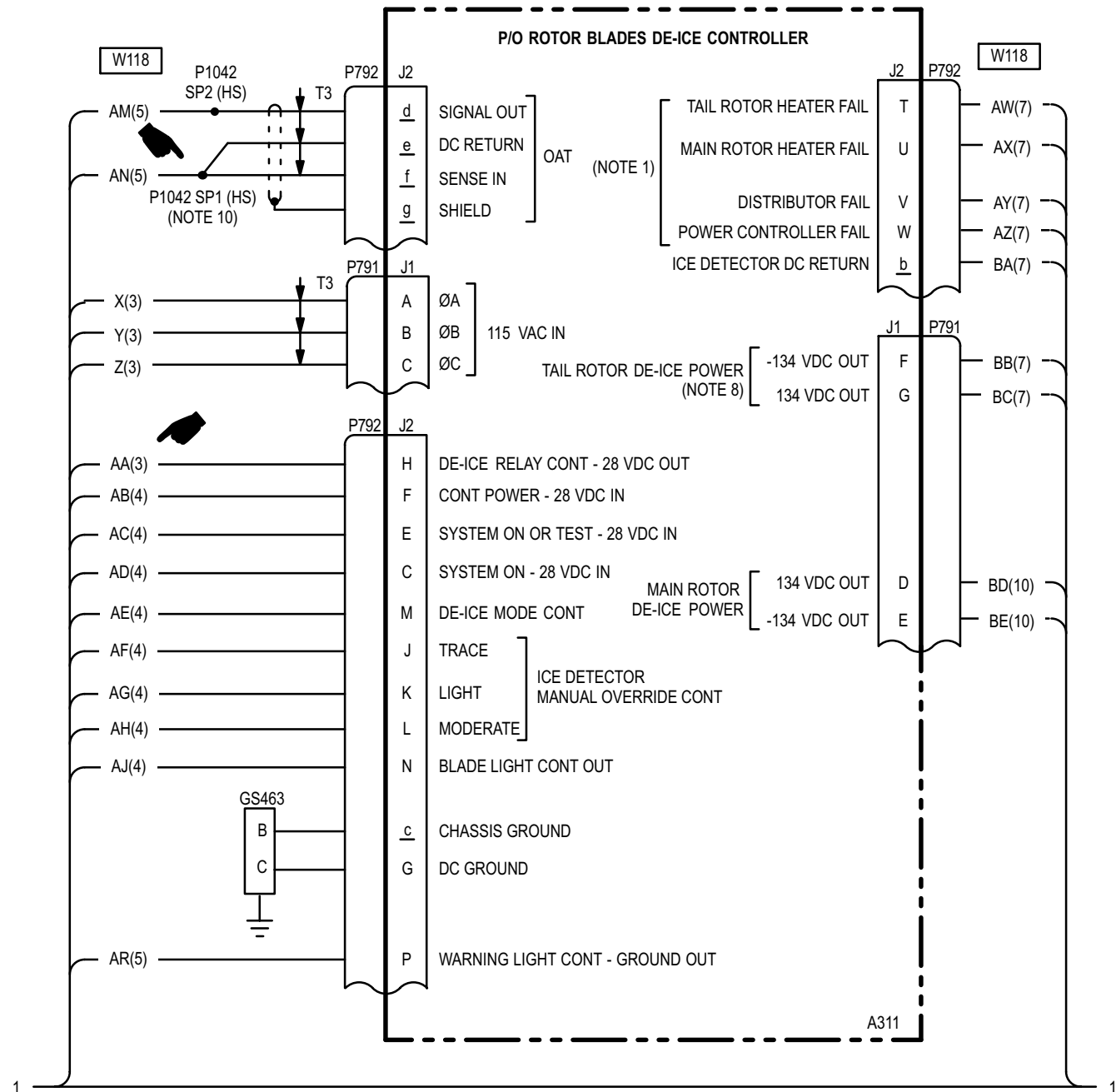



12-63. ROTOR BLADES DE-ICE - WIRING INTERCONNECT DIAGRAM (cont)

12-63

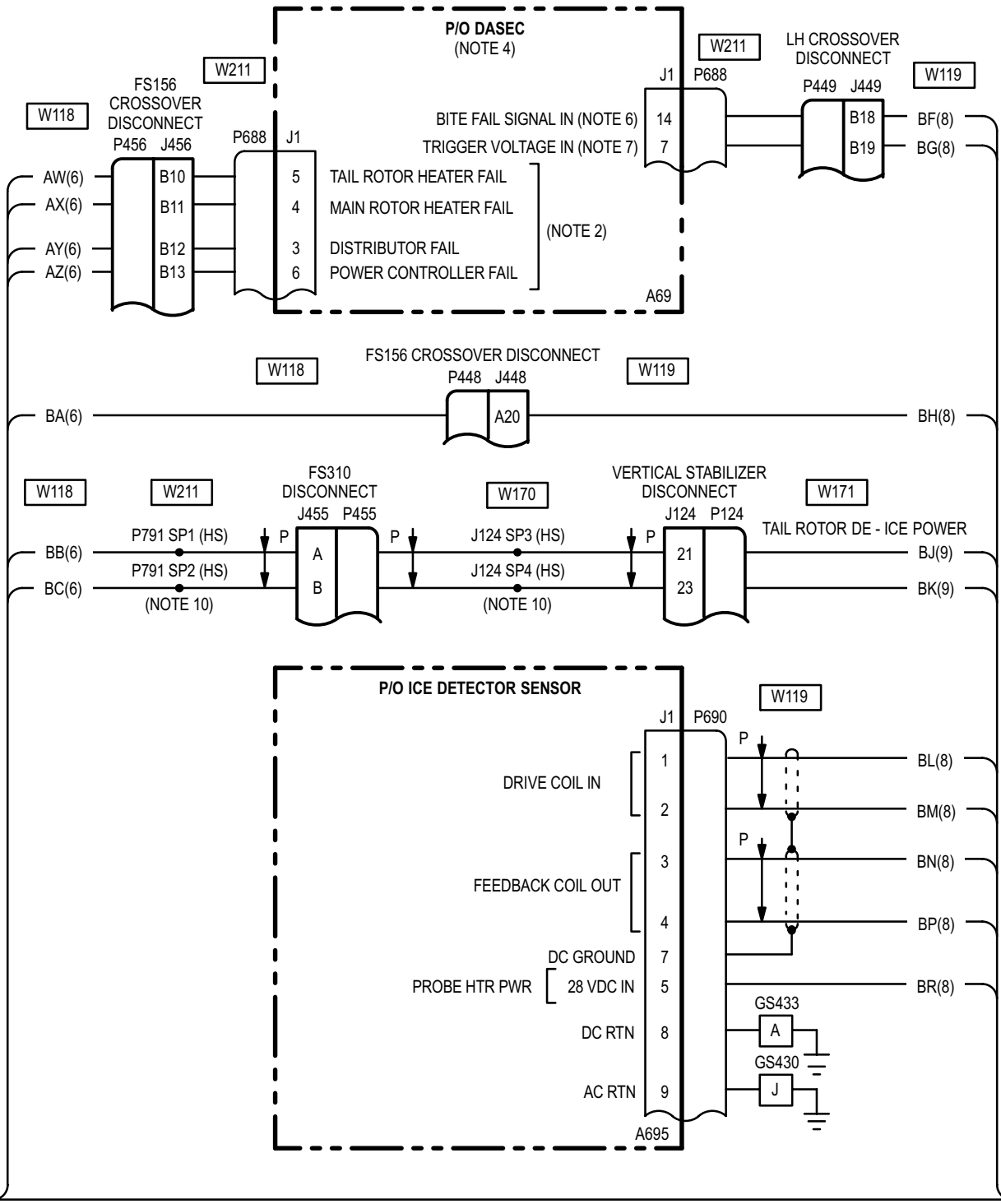

1

1

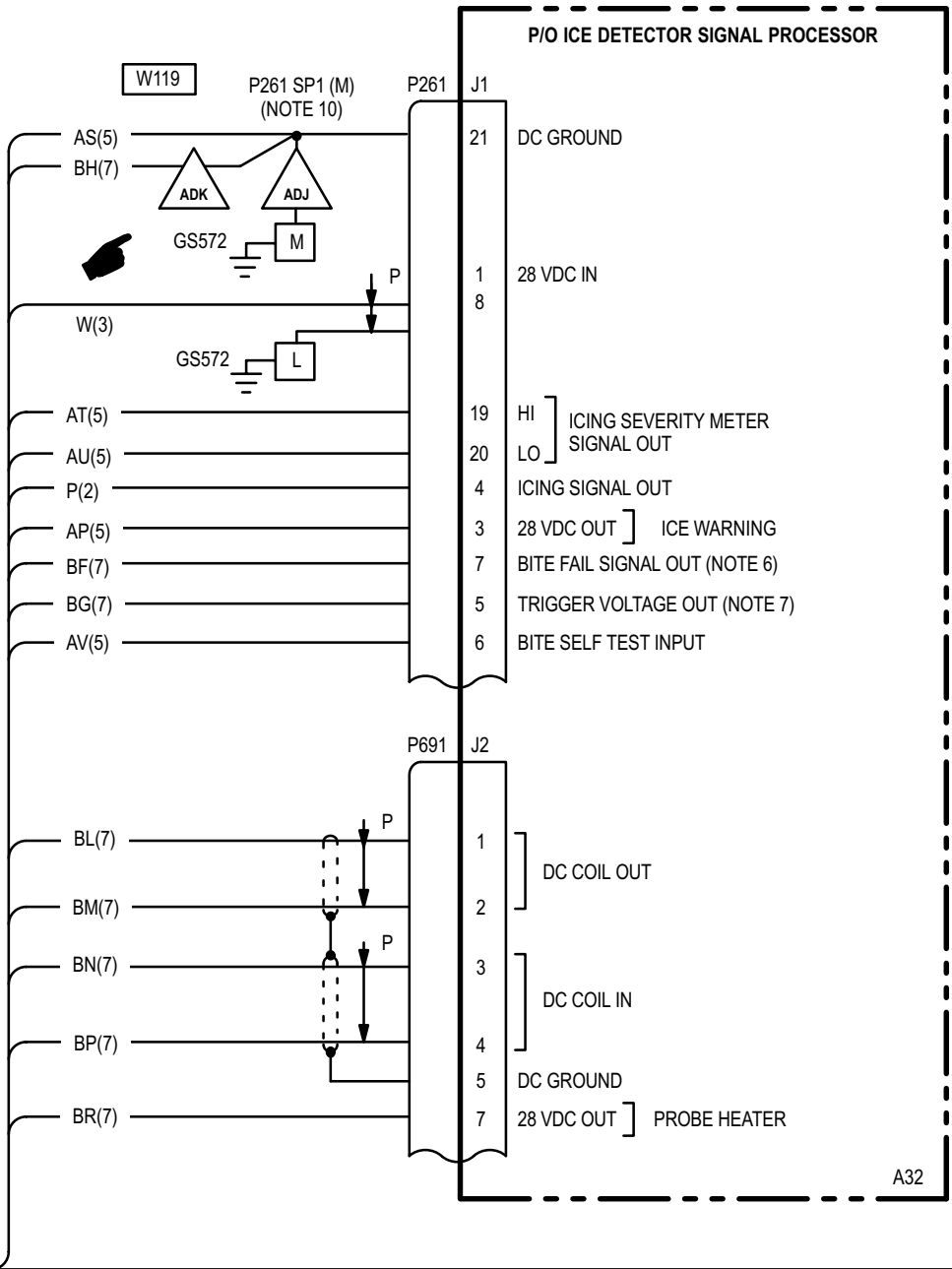

1

1

12-63. ROTOR BLADES DE-ICE - WIRING INTERCONNECT DIAGRAM (cont)

12-63

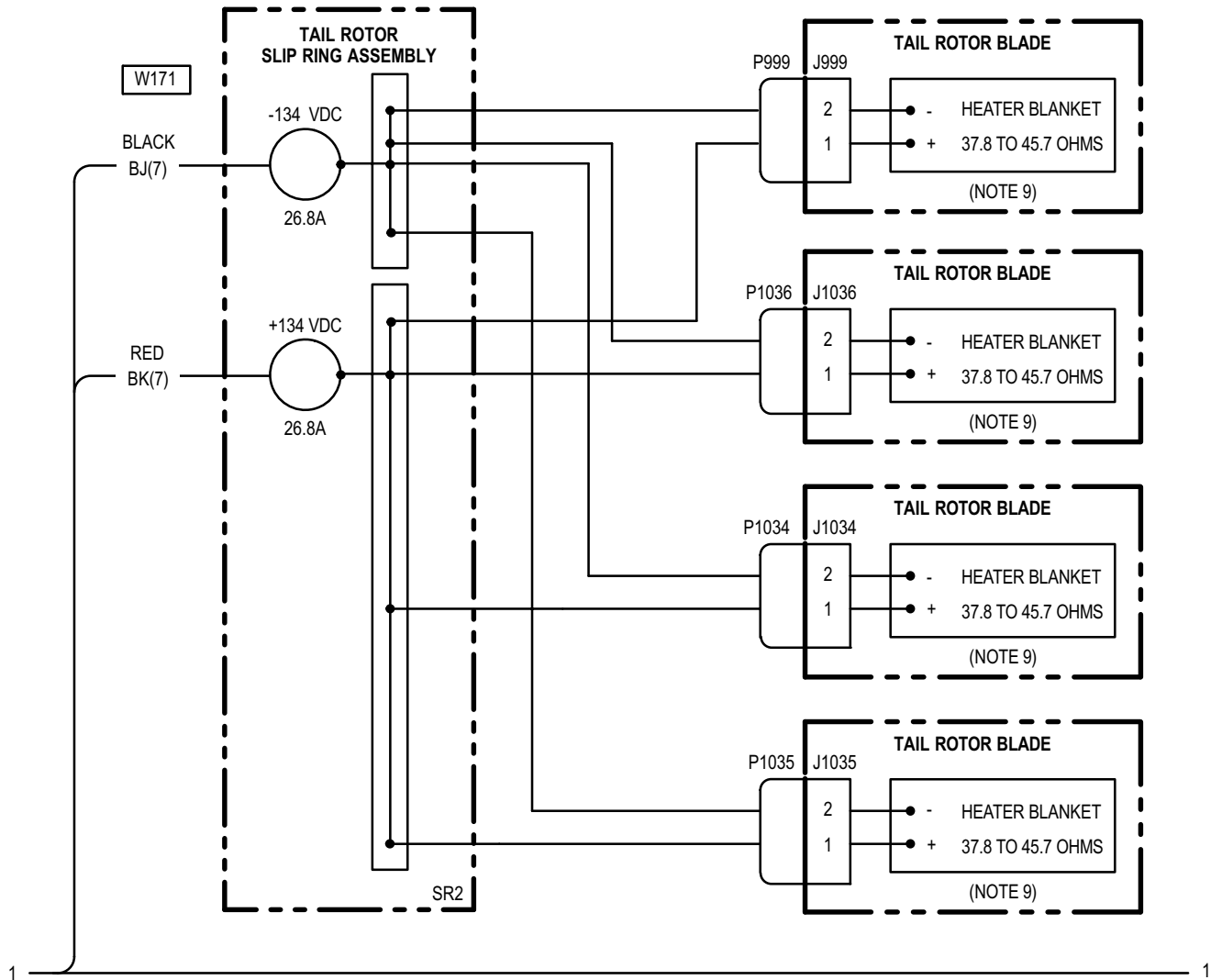

M71-217-9A  
SHEET 9 OF 11

12-63. ROTOR BLADES DE-ICE - WIRING INTERCONNECT DIAGRAM (cont)

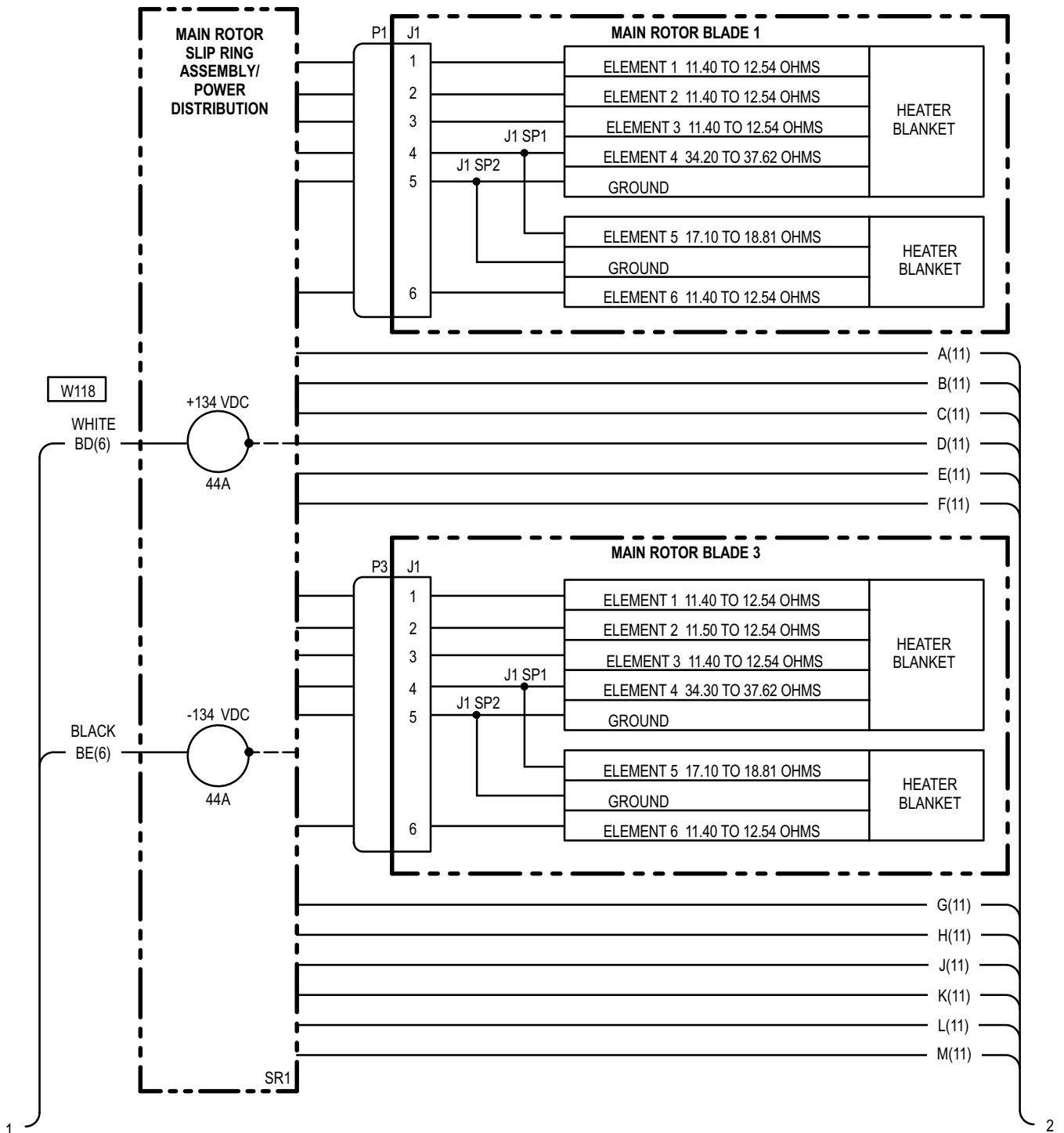

12-63. ROTOR BLADES DE-ICE - WIRING INTERCONNECT DIAGRAM (cont)

12-63

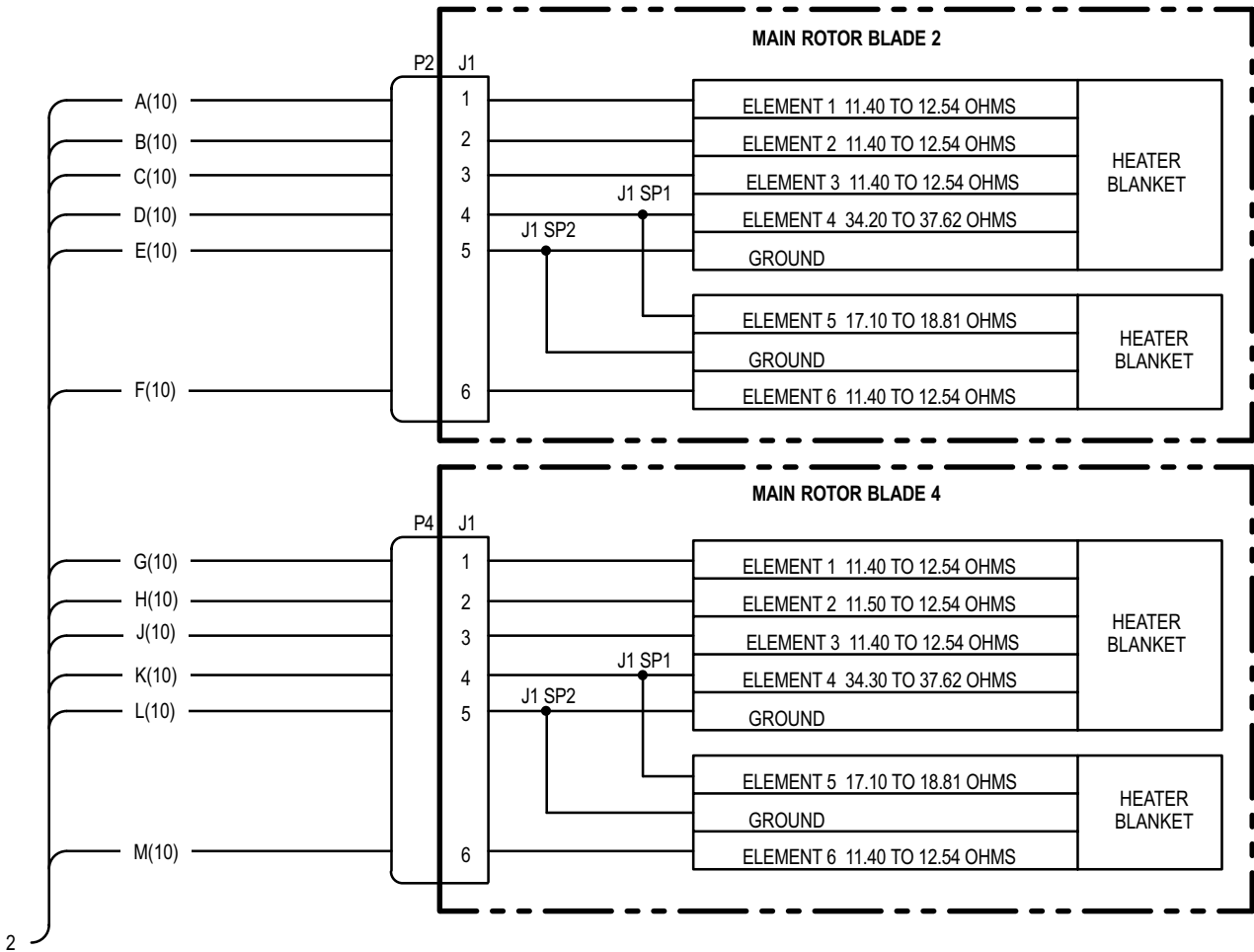

2

NOTES:

HIGHWAY USE: THE ALPHA CHARACTER IDENTIFIES A SPECIFIC LINE, AND THE NUMBER IN PARENTHESIS IDENTIFIES THE SHEET NUMBER WHERE THE SIGNAL TERMINATES.

1. 2 VDC OUT - FAIL.  
28 VDC OUT - NORMAL.
2. 2 VDC IN - FAIL.  
28 VDC IN - NORMAL.
3. ELECTRICAL SYSTEM (TM 1-1520-238-T-6).
4. FLIGHT CONTROL SYSTEM (TM 1-1520-238-T-7).
5. INSTRUMENTS (TM 1-1520-238-T-5).
6. BITE FAILURE OUTPUT 28 VDC - SENSE HEAD 0-2 VDC - SIGNAL PROCESSOR.
7. 28 VDC OUT OF TOLERANCE SIGNAL - TRIGGERS MUX BITE INPUT.
8. AVERAGE RESISTANCE VALUES FOR TAIL ROTOR BLADES ARE 8.86 TO 12.36 OHMS AT -20.0° TO 50.0° C.
9. RESISTANCE VALUES AT EACH TAIL ROTOR BLADE WHEN DISCONNECTED FROM THE PARALLEL CIRCUIT ARE 37.8 TO 45.7 OHMS.
10. HS DESIGNATES A HARD SPLICE WHICH CANNOT BE DISCONNECTED.  
M DESIGNATES A SOFT SPLICE WHICH MAY BE DISCONNECTED FOR A WIRING CHECK.
11. FIRE CONTROL SYSTEM - AIR DATA SUBSYSTEM (TM 9-1230-476-20-2).

M71-217-1 1A  
SHEET 11 OF 11

**Tools:**

<u>Nomenclature</u>	<u>Part Number</u>
Tool Kit, Electrical Repairer's	SC518099CLA06
Multimeter, Digital	AN/PSM-45

**Personnel Required:**

68X Armament/Electrical Systems Repairer

**References:**

TM 1-1520-238-T-6

TM 1-1520-238-23

<b>WARNING</b>
----------------

**Turn off power before detaching or attaching wires and connectors. High current 28 VDC or 115 VAC is present. Failure to do so could result in death or serious injury.**

1. Open **ECS BLADE DE-ICE** circuit breaker (CB85). Check for short between P1-53 and ground.

**Does short exist?**

YES	Refer to TM 1-1520-238-T-6 to troubleshoot circuit protection system (dc essential bus 3 - pilot station).
NO	Go to step 2.

2. Detach blade de-ice RCCB wire at (A402)K3-H. Check for short between wire end (A402)K3-H and ground.

**Does short exist?**

YES	Repair shorted wire between (A402): J1-53 and K3-H. Go to paragraph 12-62.
NO	Replace blade de-ice RCCB (A402)K3 (TM 1-1520-238-23).

END OF TASK

**12-65. ECS BLADE DE-ICE CONTR CIRCUIT BREAKER (CB83) - DOES NOT STAY CLOSED (BLADE DE-ICE SWITCH SET TO OFF OR TEST) 12-65**

**Tools:**

<u>Nomenclature</u>	<u>Part Number</u>
Tool Kit, Electrical Repairer's	SC518099CLA06
Multimeter, Digital	AN/PSM-45

**Personnel Required:**

68X Armament/Electrical Systems Repairer  
One person to assist

**References:**

TM 1-1520-238-T-6  
TM 1-1520-238-23

**WARNING**

**Turn off power before detaching or attaching wires and connectors. High current 28 VDC or 115 VAC is present. Failure to do so could result in death or serious injury.**

1. Open **ECS BLADE DE-ICE CONTR** circuit breaker (CB83). Check for short between P1-14 and ground.  
**Does short exist?**

YES	Refer to TM 1-1520-238-T-6 to troubleshoot circuit protection system (dc essential bus 3 - pilot station).
NO	Go to step 2.
  
2. Detach P448. Check for short between P178-29 and ground.  
**Does short exist?**

YES	Repair shorted wire between: P433-A12 and P178-29, P178-29 and J448-A19. (A402): J1-14 and J20-A12. Go to paragraph 12-62.
NO	Go to step 3.
  
3. While holding **ON/OFF/TEST** switch to **TEST**, check for short between (A135)J1-29 and chassis ground.  
**Does short exist?**

YES	Replace pilot <b>ANTI ICE</b> panel (TM 1-1520-238-23).
NO	Go to step 4.
  
4. Detach P792. Check for short between P448-A19 and ground.  
**Does short exist?**

YES	Repair shorted wire between P448-A19 and P792-F. Go to paragraph 12-62.
NO	Go to step 5.
  
5. Check for short between P178-22 and ground.  
**Does short exist?**

YES	Repair shorted wire between: P178-22 and J448-B14, P448-B14 and P792-E. Go to paragraph 12-62.
NO	Replace rotor blade de-ice controller (TM 1-1520-238-23).

END OF TASK

---

**12-66. ECS BLADE DE-ICE CONTR CIRCUIT BREAKER (CB83) - DOES NOT STAY CLOSED  
(BLADE DE-ICE SWITCH SET TO ON)**

---

12-66

**Tools:**

<u>Nomenclature</u>	<u>Part Number</u>
Tool Kit, Electrical Repairer's	SC518099CLA06
Multimeter, Digital	AN/PSM-45

**Personnel Required:**

68X Armament/Electrical Systems Repairer  
One person to assist

**References:**

TM 1-1520-238-23

---

<b>WARNING</b>
----------------

**Turn off power before detaching or attaching wires and connectors. High current 28 VDC or 115 VAC is present. Failure to do so could result in death or serious injury.**

- On pilot **ANTI ICE** panel, set **ON/OFF/TEST** switch to **ON**, check for short between (A135)J1-29 and chassis ground.  
**Does short exist?**

YES	Replace pilot <b>ANTI ICE</b> panel (TM 1-1520-238-23).
NO	Go to step 2.
- Detach P792. Check for short between P178-30 and ground.  
**Does short exist?**

YES	Repair shorted wire between: P178-30 and J448-B15, P448-B15 and P792-C. Go to paragraph 12-62.
NO	Replace rotor blade de-ice controller (TM 1-1520-238-23).

END OF TASK



**12-67. ECS ICE DET CIRCUIT BREAKER (CB68) - DOES NOT STAY CLOSED**

**12-67**

**Tools:**

<u>Nomenclature</u>	<u>Part Number</u>
Tool Kit, Electrical Repairer's	SC518099CLA06
Multimeter, Digital	AN/PSM-45

**Personnel Required:**

68X Armament/Electrical Systems Repairer

**References:**

- TM 1-1520-238-T-6
- TM 1-1520-238-23

3. Detach P261. Check for short between P457-A11 and ground.

**Does short exist?**

YES	Repair shorted wire between P457-A11 and P261-1. Go to paragraph 12-62.
NO	Replace ice detector signal processor (TM 1-1520-238-23).

**WARNING**

**Turn off power before detaching or attaching wires and connectors. High current 28 VDC or 115 VAC is present. Failure to do so could result in death or serious injury.**

1. Open **ECS ICE DET** circuit breaker (CB68). Check for short between (A402) P1-47 and ground.

**Does short exist?**

YES	Refer to TM 1-1520-238-T-6 to troubleshoot circuit protection system (dc essential bus 3 - pilot station).
NO	Go to step 2.

2. Detach P457. Check for short between (A402)J1-47 and ground.

**Does short exist?**

YES	Repair shorted wire between (A402): J1-47 and J22-A11. Go to paragraph 12-62.
NO	Go to step 3.

END OF TASK

12-68. TAIL ROTOR HEATER NO-GO TAIL ROTOR - APPEARS ON HOD

12-68

**Tools:**

<u>Nomenclature</u>	<u>Part Number</u>
Tool Kit, Electrical Repairer's	SC518099CLA06
Multimeter, Digital	AN/PSM-45

**Personnel Required:**

68X Armament/Electrical Systems Repairer  
One person to assist

**References:**

TM 1-1520-238-23



**Turn off power before detaching or attaching wires and connectors. High current 28 VDC or 115 VAC is present. Failure to do so could result in death or serious injury.**

- With OAT -4° to 77° F (-20° to 25° C), check for 37.8 to 45.7 ohms between:  
J999-1 and J999-2,  
J1034-1 and J1034-2,  
J1035-1 and J1035-2,  
J1036-1 and J1036-2.

**Is resistance present?**

- |     |   |
|-----|---|
| YES | Go to step 2.                                   |
| NO  | Replace tail rotor blade(s) (TM 1-1520-238-23). |

- Check for open between:  
P124-21 and (SR2)P999-2,  
P124-21 and P1034-2,  
P124-21 and P1035-2,  
P124-21 and P1036-2,  
P124-23 and (SR2)P999-1,  
P124-23 and P1034-1,  
P124-23 and P1035-1,  
P124-23 and P1036-1.

**Does open exist?**

- |     |   |
|-----|---|
| YES | Replace tail rotor slip ring assembly (TM 1-1520-238-23). |
| NO  | Go to step 3.   |

- Check for open between:  
P791-F and J124-21,  
P791-G and J124-23.

**Does open exist?**

- |     |   |
|-----|---|
| YES | Repair open wire.<br>Go to paragraph 12-62. |
| NO  | Go to step 4.                               |

- Check for open between P792-T and P688-5.

**Does open exist?**

- |     |   |
|-----|---|
| YES | Repair open wire.<br>Go to paragraph 12-62. |
| NO  | Go to step 5.                               |

- Check for 0 to 2 VDC at P688-5.

**Is voltage present?**

- |     |   |
|-----|---|
| YES | Replace rotor blade de-ice controller (TM 1-1520-238-23). |
| NO  | Replace DASEC (TM 1-1520-238-23).                         |

END OF TASK

**12-69. MAIN ROTOR HEATER NO-GO MAIN ROTOR - APPEARS ON HOD**

**12-69**

**Tools:**

<u>Nomenclature</u>	<u>Part Number</u>
Tool Kit, Electrical Repairer's	SC518099CLA06
Multimeter, Digital	AN/PSM-45

**Personnel Required:**

68X Armament/Electrical Systems Repairer  
One person to assist

**References:**

TM 1-1520-238-23

- Detach P1, P2, P3 and P4 at main rotor blades. With OAT -4 to 77 °F (-20 to 25 °C), check each rotor blade for 10.08 to 13.67 ohms between:  
J1-5 and J1-1,  
J1-5 and J1-2,  
J1-5 and J1-3,  
J1-5 and J1-4,  
J1-5 and J1-6.

**Is resistance present?**

- |     |   |
|-----|---|
| YES | Replace main rotor slip ring assembly/power distributor (TM 1-1520-238-23). |
| NO  | Replace rotor blade (TM 1-1520-238-23).                                     |

**WARNING**

**Turn off power before detaching or attaching wires and connectors. High current 28 VDC or 115 VAC is present. Failure to do so could result in death or serious injury.**

- Check for open between P792-U and P688-4.

**Does open exist?**

- |     |   |
|-----|---|
| YES | Repair open wire.<br>Go to paragraph 12-62. |
| NO  | Go to step 2.                               |

- Check for 0 to 2 VDC at P688-4.

**Is voltage present?**

- |     |   |
|-----|---|
| YES | Replace Rotor Blade De-Ice Controller (TM 1-1520-238-23). |
| NO  | Go to step 3.   |

END OF TASK

---

**12-70. RTR BLADE PWR CONTROLLER NO GO RH XSMN BAY (ACY), RTR BLADE PWR CONT NO GO RH XSMN BAY (ACZ) OR RTR BLADE DISTR DE-ICE NO-GO MAIN RTR MAST - APPEARS ON HOD** **12-70**

---

**Tools:**

Nomenclature	Part Number
Tool Kit, Electrical Repairer's	SC518099CLA06
Multimeter, Digital	AN/PSM-45

**Personnel Required:**

68X Armament/Electrical Systems Repairer  
One person to assist

**References:**

TM 1-1520-238-T-6  
TM 1-1520-238-23

**Equipment Conditions:**

Ref	Condition
TM 1-1520-238-23	Access provisions - R295 door opened



Turn off power before detaching or attaching wires and connectors. High current 28 VDC or 115 VAC is present. Failure to do so could result in death or serious injury.



To prevent blade damage, do not attempt to operate blade de-ice heaters when outside air temperature is above 39° F (4° C).

1. Check for open between: P792-V and P688-3, P792-W and P688-6.  
**Does open exist?**

YES	Repair open wire. Go to paragraph 12-62.
NO	Go to step 2.
  
2. Perform APU operating instructions (TM 1-1520-238-23). On pilot **ANTI ICE** panel, set **ON/OFF/TEST** switch to **ON**. Check for 28 VDC at: P792-C, P792-E, P792-F.  
**Is voltage present?**

YES	Go to step 6.
NO	Go to step 3.
  
3. Check for 28 VDC at P1-14.  
**Is voltage present?**

YES	Go to step 4.
NO	Refer to TM 1-1520-238-T-6 to troubleshoot circuit protection system (dc essential bus 3 - pilot station).
  
4. Check for open between (A402)J1-14 and P178-29.  
**Does open exist?**

YES	Repair open wire. Go to paragraph 12-62.
NO	Go to step 5.

**12-70. RTR BLADE PWR CONTROLLER NO GO RH XSMN BAY (ACY), RTR BLADE PWR CONT NO GO RH XSMN BAY (ACZ) OR RTR BLADE DISTR DE-ICE NO-GO MAIN RTR MAST - APPEARS ON HOD (cont)** **12-70**

- |  |  |   |    |  |     |                |    |               |     |  |    |               |     |               |    |   |   |     |                |    |                |     |   |    |  |     |                |    |  |     |                |    |                |     |   |    |  |
|--|--|---|----|--|-----|----------------|----|---------------|-----|--|----|---------------|-----|---------------|----|---|---|-----|----------------|----|----------------|-----|---|----|--|-----|----------------|----|--|-----|----------------|----|----------------|-----|---|----|--|
| <p>5. With <b>ON/OFF/TEST</b> switch set to <b>ON</b>, check for open between (A135):<br/>J1-29 and J1-22,<br/>J1-29 and J1-30.<br/><b>Is voltage present?</b></p> <table border="0" style="width: 100%;"> <tr> <td style="width: 10%;">YES</td> <td>Replace pilot <b>ANTI ICE</b> panel (TM 1-1520-238-23).</td> </tr> <tr> <td>NO</td> <td>Repair open wire between:<br/>P178-29 and P792-F,<br/>P178-22 and P792-E,<br/>P178-30 and P792-C.<br/>Go to paragraph 12-62.</td> </tr> </table> <p>6. Check for 115 VAC at:<br/>P791-A,<br/>P791-B,<br/>P791-C.<br/><b>Is voltage present?</b></p> <table border="0" style="width: 100%;"> <tr> <td style="width: 10%;">YES</td> <td>Go to step 15.</td> </tr> <tr> <td>NO</td> <td>Go to step 7.</td> </tr> </table> <p>7. Check for 115 VAC at (A402):<br/>K3-A2,<br/>K3-B2,<br/>K3-C2.<br/><b>Is voltage present?</b></p> <table border="0" style="width: 100%;"> <tr> <td style="width: 10%;">YES</td> <td>Repair open wire between:<br/>(A402)K3-A2 and P791-A,<br/>(A402)K3-B2 and P791-B,<br/>(A402)K3-C2 and P791-C.<br/>Go to paragraph 12-62.</td> </tr> <tr> <td>NO</td> <td>Go to step 8.</td> </tr> </table> <p>8. Check for 115 VAC between (A402):<br/>K3-A1,<br/>K3-B1,<br/>K3-C1,<br/>K3-A3,<br/>K3-B3,<br/>K3-C3.<br/><b>Is voltage present?</b></p> <table border="0" style="width: 100%;"> <tr> <td style="width: 10%;">YES</td> <td>Go to step 9.</td> </tr> <tr> <td>NO</td> <td>Refer to TM 1-1520-238-T-6 to troubleshoot ac electrical power generation system.</td> </tr> </table> | YES  | Replace pilot <b>ANTI ICE</b> panel (TM 1-1520-238-23). | NO | Repair open wire between:<br>P178-29 and P792-F,<br>P178-22 and P792-E,<br>P178-30 and P792-C.<br>Go to paragraph 12-62. | YES | Go to step 15. | NO | Go to step 7. | YES | Repair open wire between:<br>(A402)K3-A2 and P791-A,<br>(A402)K3-B2 and P791-B,<br>(A402)K3-C2 and P791-C.<br>Go to paragraph 12-62. | NO | Go to step 8. | YES | Go to step 9. | NO | Refer to TM 1-1520-238-T-6 to troubleshoot ac electrical power generation system. | <p>9. Check for 28 VDC at (A402)K3-H.<br/><b>Is voltage present?</b></p> <table border="0" style="width: 100%;"> <tr> <td style="width: 10%;">YES</td> <td>Go to step 11.</td> </tr> <tr> <td>NO</td> <td>Go to step 10.</td> </tr> </table> <p>10. Check for 28 VDC at (A76)P1-53.<br/><b>Is voltage present?</b></p> <table border="0" style="width: 100%;"> <tr> <td style="width: 10%;">YES</td> <td>Repair open wire between (A402):<br/>J1-53 and K3-H.<br/>Go to paragraph 12-62.</td> </tr> <tr> <td>NO</td> <td>Refer to TM 1-1520-238-T-6 to troubleshoot circuit protection system (dc essential bus 3 - pilot station).</td> </tr> </table> <p>11. With wire end at (A402)K3-G detached, check for 28 VDC at (A402)K3-G.<br/><b>Is voltage present?</b></p> <table border="0" style="width: 100%;"> <tr> <td style="width: 10%;">YES</td> <td>Go to step 12.</td> </tr> <tr> <td>NO</td> <td>Replace blade de-ice RCCB (A402)K3 (TM 1-1520-238-23).</td> </tr> </table> <p>12. Check for 28 VDC at (A402)XK1-6-X1.<br/><b>Is voltage present?</b></p> <table border="0" style="width: 100%;"> <tr> <td style="width: 10%;">YES</td> <td>Go to step 14.</td> </tr> <tr> <td>NO</td> <td>Go to step 13.</td> </tr> </table> <p>13. Check for open between:<br/>P792-H and (A402)XK1-6-X1,<br/>P792-c and GS463-B,<br/>P792-G and GS463-C.<br/><b>Does open exist?</b></p> <table border="0" style="width: 100%;"> <tr> <td style="width: 10%;">YES</td> <td>Repair open wire.<br/>Go to paragraph 12-62.</td> </tr> <tr> <td>NO</td> <td>Replace blade de-ice RCCB (A402)K3 (TM 1-1520-238-23).</td> </tr> </table> | YES | Go to step 11. | NO | Go to step 10. | YES | Repair open wire between (A402):<br>J1-53 and K3-H.<br>Go to paragraph 12-62. | NO | Refer to TM 1-1520-238-T-6 to troubleshoot circuit protection system (dc essential bus 3 - pilot station). | YES | Go to step 12. | NO | Replace blade de-ice RCCB (A402)K3 (TM 1-1520-238-23). | YES | Go to step 14. | NO | Go to step 13. | YES | Repair open wire.<br>Go to paragraph 12-62. | NO | Replace blade de-ice RCCB (A402)K3 (TM 1-1520-238-23). |
| YES  | Replace pilot <b>ANTI ICE</b> panel (TM 1-1520-238-23).  |   |    |  |     |                |    |               |     |  |    |               |     |               |    |   |   |     |                |    |                |     |   |    |  |     |                |    |  |     |                |    |                |     |   |    |  |
| NO   | Repair open wire between:<br>P178-29 and P792-F,<br>P178-22 and P792-E,<br>P178-30 and P792-C.<br>Go to paragraph 12-62.             |   |    |  |     |                |    |               |     |  |    |               |     |               |    |   |   |     |                |    |                |     |   |    |  |     |                |    |  |     |                |    |                |     |   |    |  |
| YES  | Go to step 15.   |   |    |  |     |                |    |               |     |  |    |               |     |               |    |   |   |     |                |    |                |     |   |    |  |     |                |    |  |     |                |    |                |     |   |    |  |
| NO   | Go to step 7.  |   |    |  |     |                |    |               |     |  |    |               |     |               |    |   |   |     |                |    |                |     |   |    |  |     |                |    |  |     |                |    |                |     |   |    |  |
| YES  | Repair open wire between:<br>(A402)K3-A2 and P791-A,<br>(A402)K3-B2 and P791-B,<br>(A402)K3-C2 and P791-C.<br>Go to paragraph 12-62. |   |    |  |     |                |    |               |     |  |    |               |     |               |    |   |   |     |                |    |                |     |   |    |  |     |                |    |  |     |                |    |                |     |   |    |  |
| NO   | Go to step 8.  |   |    |  |     |                |    |               |     |  |    |               |     |               |    |   |   |     |                |    |                |     |   |    |  |     |                |    |  |     |                |    |                |     |   |    |  |
| YES  | Go to step 9.  |   |    |  |     |                |    |               |     |  |    |               |     |               |    |   |   |     |                |    |                |     |   |    |  |     |                |    |  |     |                |    |                |     |   |    |  |
| NO   | Refer to TM 1-1520-238-T-6 to troubleshoot ac electrical power generation system.  |   |    |  |     |                |    |               |     |  |    |               |     |               |    |   |   |     |                |    |                |     |   |    |  |     |                |    |  |     |                |    |                |     |   |    |  |
| YES  | Go to step 11.   |   |    |  |     |                |    |               |     |  |    |               |     |               |    |   |   |     |                |    |                |     |   |    |  |     |                |    |  |     |                |    |                |     |   |    |  |
| NO   | Go to step 10.   |   |    |  |     |                |    |               |     |  |    |               |     |               |    |   |   |     |                |    |                |     |   |    |  |     |                |    |  |     |                |    |                |     |   |    |  |
| YES  | Repair open wire between (A402):<br>J1-53 and K3-H.<br>Go to paragraph 12-62.  |   |    |  |     |                |    |               |     |  |    |               |     |               |    |   |   |     |                |    |                |     |   |    |  |     |                |    |  |     |                |    |                |     |   |    |  |
| NO   | Refer to TM 1-1520-238-T-6 to troubleshoot circuit protection system (dc essential bus 3 - pilot station).                           |   |    |  |     |                |    |               |     |  |    |               |     |               |    |   |   |     |                |    |                |     |   |    |  |     |                |    |  |     |                |    |                |     |   |    |  |
| YES  | Go to step 12.   |   |    |  |     |                |    |               |     |  |    |               |     |               |    |   |   |     |                |    |                |     |   |    |  |     |                |    |  |     |                |    |                |     |   |    |  |
| NO   | Replace blade de-ice RCCB (A402)K3 (TM 1-1520-238-23).   |   |    |  |     |                |    |               |     |  |    |               |     |               |    |   |   |     |                |    |                |     |   |    |  |     |                |    |  |     |                |    |                |     |   |    |  |
| YES  | Go to step 14.   |   |    |  |     |                |    |               |     |  |    |               |     |               |    |   |   |     |                |    |                |     |   |    |  |     |                |    |  |     |                |    |                |     |   |    |  |
| NO   | Go to step 13.   |   |    |  |     |                |    |               |     |  |    |               |     |               |    |   |   |     |                |    |                |     |   |    |  |     |                |    |  |     |                |    |                |     |   |    |  |
| YES  | Repair open wire.<br>Go to paragraph 12-62.  |   |    |  |     |                |    |               |     |  |    |               |     |               |    |   |   |     |                |    |                |     |   |    |  |     |                |    |  |     |                |    |                |     |   |    |  |
| NO   | Replace blade de-ice RCCB (A402)K3 (TM 1-1520-238-23).   |   |    |  |     |                |    |               |     |  |    |               |     |               |    |   |   |     |                |    |                |     |   |    |  |     |                |    |  |     |                |    |                |     |   |    |  |

---

**12-70. RTR BLADE PWR CONTROLLER NO GO RH XSMN BAY (ACY), RTR BLADE PWR CONT NO GO RH XSMN BAY (ACZ) OR RTR BLADE DISTR DE-ICE NO-GO MAIN RTR MAST - APPEARS ON HOD (cont)**

---

**12-70**

14. Check for open between:  
(A402)XK1-6-X2 and GS6-H,  
(A402)XK1-6-A1 and GS6-J,  
(A402)XK1-6-A2 and K3-G.  
**Does open exist?**
- |     |   |
|-----|---|
| YES | Repair open wire.<br>Go to paragraph 12-62.     |
| NO  | Replace relay (A402)K1-6<br>(TM 1-1520-238-23). |
15. Check for open between P792-b and ground.  
**Does open exist?**
- |     |   |
|-----|---|
| YES | Repair open wire.<br>Go to paragraph 12-62. |
| NO  | Go to step 16.                              |
16. Check for open between:  
P1042-A and P792-d,  
P1042-B and P792-e,  
P1042-B and P792-f.  
**Does open exist?**
- |     |   |
|-----|---|
| YES | Repair open wire.<br>Go to paragraph 12-62. |
| NO  | Go to step 17.                              |
17. Check for resistance between (A176):  
J1-A and J1-B:  
90.38 ± 0.40 ohms 32° F (0° C),  
97.31 ± 10.40 ohms -4° F (-20° C).  
**Is resistance present?**
- |     |   |
|-----|---|
| YES | Go to step 18.                            |
| NO  | Replace OAT sensor<br>(TM 1-1520-238-23). |
18. Check for short between (A135):  
J1-32 and ground,  
J1-33 and ground,  
J1-35 and ground,  
J1-36 and ground,  
J1-37 and ground.  
**Does short exist?**
- |     |  |
|-----|--|
| YES | Replace pilot <b>ANTI ICE</b> panel<br>(TM 1-1520-238-23). |
| NO  | Go to step 19.   |
19. Detach P178. Check for short between:  
P792-J and ground,  
P792-K and ground,  
P792-L and ground,  
P792-M and ground.  
**Does short exist?**
- |     |  |
|-----|--|
| YES | Repair shorted wire.<br>Go to paragraph 12-62. |
| NO  | Go to step 20.                                 |
20. On pilot **ANTI ICE** panel, set  
**AUTO/TRACE/LT/MOD** switch to **AUTO**. Check  
for open between P261-4 and P792-M.  
**Does open exist?**
- |     |                |
|-----|----------------|
| YES | Go to step 21. |
| NO  | Go to step 23. |
21. Check for open between (A135):  
J1-32 and J1-33.  
**Does open exist?**
- |     |  |
|-----|--|
| YES | Replace pilot <b>ANTI ICE</b> panel<br>(TM 1-1520-238-23). |
| NO  | Go to step 22.   |
22. Check for open between P178-32 and P792-M.  
**Does open exist?**
- |     |   |
|-----|---|
| YES | Repair open wire.<br>Go to paragraph 12-62.                               |
| NO  | Repair open wire between<br>P178-33 and P261-4.<br>Go to paragraph 12-62. |
23. Check for 0 to 2 VDC at:  
P688-3,  
P688-6.  
**Is voltage present?**
- |     |   |
|-----|---|
| YES | Replace rotor blades de-ice<br>controller (TM 1-1520-238-23). |
| NO  | Replace DASEC<br>(TM 1-1520-238-23).                          |

END OF TASK

**12-71. BLADE DE-ICE ON INDICATOR - DOES NOT LIGHT**

**12-71**

**Tools:**

<u>Nomenclature</u>	<u>Part Number</u>
Tool Kit, Electrical Repairer's	SC518099CLA06
Multimeter, Digital	AN/PSM-45

**Personnel Required:**

68X Armament/Electrical Systems Repairer  
One person to assist

**References:**

TM 1-1520-238-T-6  
TM 1-1520-238-23

**Equipment Conditions:**

<u>Ref</u>	<u>Condition</u>
TM 1-1520-238-23	Access provisions - L60 fairing removed



**Turn off power before detaching or attaching wires and connectors. High current 28 VDC or 115 VAC is present. Failure to do so could result in death or serious injury.**

- On pilot **ANTI ICE** panel, set **ON/OFF/TEST** switch to **ON**. Check for 28 VDC at P748-U.  
**Is voltage present?**

YES Go to step 2.

NO Go to step 4.

- Check for open between (A135): J1-19 and J1-20.

**Does open exist?**

YES Replace pilot **ANTI ICE** panel (TM 1-1520-238-23).

NO Go to step 3.

- Check for open between: P178-19 and P748-S, P178-20 and P748-T.

**Does open exist?**

YES Repair open wire.  
Go to paragraph 12-62.

NO Replace multi-channel dimming controller (TM 1-1520-238-23).

- Check for 28 VDC at P1-14.

**Is voltage present?**

YES Go to step 5.

NO Refer to TM 1-1520-238-T-6 to troubleshoot circuit protection system (dc essential bus 3 - pilot station).

- Check for 28 VDC at P792-F.

**Is voltage present?**

YES Go to step 6.

NO Repair open wire between: P792-F and P178-29, P792-F and P433-A12.  
Go to paragraph 12-62.

- On pilot **ANTI ICE** panel, set **ON/OFF/TEST** switch to **ON**. Check for 28 VDC at P792-E.

**Is voltage present?**

YES Go to step 7.

NO Go to step 8.

- Check for open between P748-U and P792-N.

**Does open exist?**

YES Repair open wire.  
Go to paragraph 12-62.

NO Replace rotor blade de-ice controller (TM 1-1520-238-23).

---

12-71. BLADE DE-ICE ON INDICATOR - DOES NOT LIGHT (cont)

---

12-71

8. Check for open between P792-E and P178-22.

**Does open exist?**

- |     |  |
|-----|--|
| YES | Repair open wire.<br>Go to paragraph 12-62.                |
| NO  | Replace pilot <b>ANTI ICE</b> panel<br>(TM 1-1520-238-23). |

END OF TASK



**12-72. BLADE ANTI-ICE FAIL INDICATOR - DOES NOT LIGHT**

12-72

**Tools:**

<u>Nomenclature</u>	<u>Part Number</u>
Tool Kit, Electrical Repairer's	SC518099CLA06
Multimeter, Digital	AN/PSM-45

**Personnel Required:**

68X Armament/Electrical Systems Repairer  
One person to assist

**References:**

TM 1-1520-238-23

**Equipment Conditions:**

<u>Ref</u>	<u>Condition</u>
TM 1-1520-238-23	Access provisions - R295 door opened

<b>WARNING</b>
----------------

**Turn off power before detaching or attaching wires and connectors. High current 28 VDC or 115 VAC is present. Failure to do so could result in death or serious injury.**

1. Check for 28 VDC at P792-P.

**Is voltage present?**

YES	Refer to paragraph 12-70 to troubleshoot rotor blade de-ice power distribution.
NO	Go to step 2.

2. Check for 28 VDC at (A106)J1-75.

**Is voltage present?**

YES	Repair open wire between P18-75 and P792-P. Go to paragraph 12-62.
NO	Replace pilot caution/warning panel (TM 1-1520-238-23).

END OF TASK

12-73. ICING SEVERITY METER - DOES NOT INDICATE 1.5 G/M<sup>3</sup> (TEST CONDITION)

12-73

**Tools:**

<u>Nomenclature</u>	<u>Part Number</u>
Tool Kit, Electrical Repairer's	SC518099CLA06
Multimeter, Digital	AN/PSM-45

**Personnel Required:**

68X Armament/Electrical Systems Repairer  
One person to assist

**References:**

TM 1-1520-238-T-6  
TM 1-1520-238-23

4. With icing severity meter **PRESS TO TEST** switch pressed, check for open between (A331-M1) + and P261-20.

**Does open exist?**

- YES Repair open wire.  
Go to paragraph 12-62.
- NO Replace ice detector signal processor (TM 1-1520-238-23).

5. Check for open between P527-A3 and P261-21.

**Does open exist?**

- YES Repair open wire.  
Go to paragraph 12-62.
- NO Replace icing severity meter (TM 1-1520-238-23).



**Turn off power before detaching or attaching wires and connectors. High current 28 VDC or 115 VAC is present. Failure to do so could result in death or serious injury.**

1. With icing severity meter **PRESS TO TEST** switch pressed, check for 7.5 VDC between (A331-M1) + (positive) terminal and ground.  
**Is voltage present?**

- YES Go to step 5.
- NO Go to step 2.

2. Check for 28 VDC at P261-1.  
**Is voltage present?**

- YES Go to step 4.
- NO Go to step 3.

3. Check for 28 VDC P1-47.  
**Is voltage present?**

- YES Repair open wire between (A402)J1-47 and P261-1.  
Go to paragraph 12-62.
- NO Refer to TM 1-1520-238-T-6 to troubleshoot circuit protection system (dc essential bus 3 - pilot station).

END OF TASK

---

**12-74. ICING SEVERITY METER - DOES NOT INDICATE GREATER THAN 0.0 G/M<sup>3</sup>  
(ENG ICE INDICATOR IS LIGHTED)**

---

12-74

**Tools:**

<u>Nomenclature</u>	<u>Part Number</u>
Tool Kit, Electrical Repairer's	SC518099CLA06
Multimeter, Digital	AN/PSM-45

**Personnel Required:**

68X Armament/Electrical Systems Repairer

**References:**

TM 1-1520-238-23

<b>WARNING</b>
----------------

**Turn off power before detaching or attaching wires and connectors. High current 28 VDC or 115 VAC is present. Failure to do so could result in death or serious injury.**

1. Check for open between P527-A2 and P261-19.

**Does open exist?**

YES	Repair open wire. Go to paragraph 12-62.
NO	Go to step 2.

2. Check for short between P527-A2 and ground.

**Does open exist?**

YES	Repair shorted wire between P527-A2 and P261-19. Go to paragraph 12-62.
NO	Go to step 3.

3. Check for open between:

P691-1 and P690-1,  
P691-2 and P690-2.

**Does open exist?**

YES	Repair open wire. Go to paragraph 12-62.
NO	Replace ice detector sensor (TM 1-1520-238-23).

END OF TASK

---

**12-75. ENG ICE INDICATOR - DOES NOT LIGHT (ICING SEVERITY METER INDICATES GREATER THAN 0.0 G/M<sup>3</sup>)**

---

12-75

**Tools:**

<u>Nomenclature</u>	<u>Part Number</u>
Tool Kit, Electrical Repairer's	SC518099CLA06
Multimeter, Digital	AN/PSM-45

**Personnel Required:**

68X Armament/Electrical Systems Repairer  
One person to assist

**References:**

TM 1-1520-238-T-6  
TM 1-1520-238-23

---

<b>WARNING</b>
----------------

**Turn off power before detaching or attaching wires and connectors. High current 28 VDC or 115 VAC is present. Failure to do so could result in death or serious injury.**

1. Check for 28 VDC at P18-73.

**Is voltage present?**

YES	Refer to TM 1-1520-238-T-6 to troubleshoot pilot caution/warning system.
NO	Go to step 2.

2. Check for open between: P18-73 and P261-3.

**Does open exist?**

YES	Repair open wire. Go to paragraph 12-62.
NO	Replace ice detector signal processor (TM 1-1520-238-23).

END OF TASK

**12-76. ICING SEVERITY METER - DOES NOT BRIGHTEN****12-76****Tools:**

<u>Nomenclature</u>	<u>Part Number</u>
Tool Kit, Electrical Repairer's	SC518099CLA06
Multimeter, Digital	AN/PSM-45

**Personnel Required:**

68X Armament/Electrical Systems Repairer  
One person to assist

**References:**

TM 1-1520-238-23

<b>WARNING</b>
----------------

**Turn off power before detaching or attaching wires and connectors. High current 28 VDC or 115 VAC is present. Failure to do so could result in death or serious injury.**

1. Check for 5 VDC between P527-A9 and P527-A8.

**Is voltage present?**

YES	Replace icing severity meter (TM 1-1520-238-23).
NO	Go to step 2.

2. Check for open between:  
P487-A7 and P527-A9  
P487-A8 and P527-A8.  
(A326):

TB1-31-F and J9-A7,  
TB1-32-F and J9-A8.

**Is voltage present?**

YES	Repair open wire. Go to paragraph 12-62.
NO	Refer to TM 1-1520-238-T-6 to troubleshoot pilot edge-lights.

END OF TASK

**Tools:**

<u>Nomenclature</u>	<u>Part Number</u>
Tool Kit, Electrical Repairer's	SC518099CLA06
Multimeter, Digital	AN/PSM-45

**Personnel Required:**

68X Armament/Electrical Systems Repairer  
One person to assist

**References:**

TM 1-1520-238-23

---

<b>WARNING</b>
----------------

**Turn off power before detaching or attaching wires and connectors. High current 28 VDC or 115 VAC is present. Failure to do so could result in death or serious injury.**

1. Check for 28 VDC at P18-73.

**Is voltage present?**

YES	Go to step 2.
NO	Replace pilot caution/warning panel (TM 1-1520-238-23).

2. Check probe for damage.

**Is damage present?**

YES	Replace ice detector sensing head (probe) (TM 1-1520-238-23).
NO	Replace ice detector signal processor (TM 1-1520-238-23).

END OF TASK

**12-78. ICE DETECTOR CONTROLLER NO-GO FIREWALL LH SIDE - APPEARS ON HOD**

**12-78**

**Tools:**

<u>Nomenclature</u>	<u>Part Number</u>
Tool Kit, Electrical Repairer's	SC518099CLA06
Multimeter, Digital	AN/PSM-45

**Personnel Required:**

68X Armament/Electrical Systems Repairer  
One person to assist

**References:**

TM 1-1520-238-T-6  
TM 1-1520-238-23

**Equipment Conditions:**

<u>Ref</u>	<u>Condition</u>
TM 1-1520-238-23	Access provisions - L325, R295, T250L, T250R, T290L and T290R doors opened

**WARNING**

**Turn off power before detaching or attaching wires and connectors. High current 28 VDC or 115 VAC is present. Failure to do so could result in death or serious injury.**

1. Check for open between P261-7 and P688-14.  
**Does open exist?**

YES	Repair open wire. Go to paragraph 12-62.
NO	Go to step 2.

2. Detach P688. Check for short between P261-7 and ground.  
**Does short exist?**

YES	Repair shorted wire between: P261-7 and J449-B18, P449-B18 and P688-7. Go to paragraph 12-62.
NO	Go to step 3.

3. Check for 28 VDC at P261-1.  
**Is voltage present?**

YES	Go to step 5.
NO	Go to step 4.

4. Check for 28 VDC at P1-47.  
**Is voltage present?**

YES	Repair open wire between: P457-A11 and P261-1. (A402): J1-47 and J22-A11. Go to paragraph 12-62.
NO	Refer to TM 1-1520-238-T-6 to troubleshoot circuit protection system (dc essential bus 3 - pilot station).

5. Check for open between P261-8 and ground.  
**Does open exist?**

YES	Repair open wire between P261-8 and GS572-L. Go to paragraph 12-62.
NO	Replace ice detector signal processor (TM 1-1520-238-23).

END OF TASK

**12-79. ICE DETECTOR SENSOR NO-GO ENG INLET LH SIDE (ACY) OR  
ICE DETECTOR SENSOR NO-GO DOGHOUSE FAIRING(ACZ)**

**12-79**

**Tools:**

<u>Nomenclature</u>	<u>Part Number</u>
Tool Kit, Electrical Repairer's	SC518099CLA06
Multimeter, Digital	AN/PSM-45

**Personnel Required:**

68X Armament/Electrical Systems Repairer

**References:**

TM 1-1520-238-T-1  
TM 1-1520-238-23

3. Check for open between (A695):  
J1-1 and J1-2,  
J1-3 and J1-4.

**Does open exist?**

YES	Replace ice detector sensor (TM 1-1520-238-23).
NO	Repair open wire between: P691-1 and P690-1, P691-2 and P690-2, P691-3 and P690-3, P691-4 and P690-4. Go to paragraph 12-62.

**WARNING**

**Turn off power before detaching or attaching wires and connectors. High current 28 VDC or 115 VAC is present. Failure to do so could result in death or serious injury.**

1. Visually inspect ice detector sensor for damage.

**Is sensor damaged?**

YES	Replace ice detector sensor (TM 1-1520-238-23).
NO	Go to step 2.

2. Check for open between:

P691-1 and P691-2,  
P691-3 and P691-4.

**Does open exist?**

YES	Go to step 3.
NO	Replace ice detector signal processor (TM 1-1520-238-23).

END OF TASK



---

**12-80. ECS ENG ANTI-ICE CIRCUIT BREAKER (CB67) - DOES NOT STAY CLOSED  
(PITOT ICE DET AD SNSR SWITCH ON)**

---

12-80

**Tools:**

<u>Nomenclature</u>	<u>Part Number</u>
Tool Kit, Electrical Repairer's	SC518099CLA06
Multimeter, Digital	AN/PSM-45

**Personnel Required:**

68X Armament/Electrical Systems Repairer

**References:**

TM 1-1520-238-T-6

TM 1-1520-238-23

**WARNING**

**Turn off power before detaching or attaching wires and connectors. High current 28 VDC or 115 VAC is present. Failure to do so could result in death or serious injury.**

1. Detach P1. Check for short between P1-4 and ground.

**Does short exist?**

YES	Refer to TM 1-1520-238-T-6 to troubleshoot circuit protection system (dc essential bus 1 - pilot station).
NO	Go to step 2.

2. Check for short between P872-A and ground.

**Does short exist?**

YES	Repair shorted wire between: P433-B1 and P872-A. (A402): J1-4 and TB3-16-L, TB3-16-M and XK5-10-A2, XK5-10-A1 and J20-B1. Go to paragraph 12-62.
NO	Replace solenoid valve (TM 1-1520-238-23).

END OF TASK

**12-81. AIRFLOW THROUGH ICE DETECTOR SENSOR - DOES NOT STOP  
(PITOT ICE DET AD SNSR SWITCH OFF)**

**Tools:**

<u>Nomenclature</u>	<u>Part Number</u>
Tool Kit, Electrical Repairer's	SC518099CLA06
Multimeter, Digital	AN/PSM-45

**Personnel Required:**

68X Armament/Electrical Systems Repairer  
One person to assist

**References:**

TM 1-1520-238-23

**Equipment Conditions:**

<u>Ref</u>	<u>Condition</u>
TM 1-1520-238-23	Access provisions - T205L fairing removed

**WARNING**

**Turn off power before detaching or attaching wires and connectors. High current 28 VDC or 115 VAC is present. Failure to do so could result in death or serious injury.**

1. Check for 28 VDC at P872-A.  
**Is voltage present?**

YES	Go to step 2.
NO	Replace ice detector warm air supply valve (TM 1-1520-238-23).
  
2. Check for 28 VDC at P433-B3.  
**Is voltage present?**

YES	Go to step 3.
NO	Go to step 4.

3. Detach P178. Check for 28 VDC at P433-B3.  
**Is voltage present?**

YES	Repair shorted wire between P178-17 and P433-B3. Go to paragraph 12-62.
NO	Replace pilot <b>ANTI ICE</b> panel (TM 1-1520-238-23).
  
4. Check for 28 VDC at (A402)J20-B1.  
**Is voltage present?**

YES	Go to step 5.
NO	Repair shorted wire between P872-A and P433-B1. Go to paragraph 12-62.
  
5. Check for 28 VDC at wire end (A402)XK5-10-X1.  
**Is voltage present?**

YES	Repair shorted wire between (A402): J20-B1 and wire end XK5-10-X1. Go to paragraph 12-62.
NO	Go to step 6.
  
6. Check for 28 VDC at (A402)XK5-10-A1.  
**Is voltage present?**

YES	Replace relay (A402)K5-10 (TM 1-1520-238-23).
NO	Repair shorted wire between (A402): J20-B1 and XK5-10-A2. Go to paragraph 12-62.

END OF TASK

**12-82. NO AIRFLOW THROUGH ICE DETECTOR SENSOR - (PITOT ICE DET AD SNSR SWITCH ON)**

12-82

**Tools:**

<u>Nomenclature</u>	<u>Part Number</u>
Tool Kit, Electrical Repairer's	SC518099CLA06
Multimeter, Digital	AN/PSM-45

**Personnel Required:**

68X Armament/Electrical Systems Repairer  
One person to assist

**References:**

TM 1-1520-238-23

**Equipment Conditions:**

<u>Ref</u>	<u>Condition</u>
TM 1-1520-238-23	Access provisions - L200 panel and T205 and L205 fairings removed

**WARNING**

**Turn off power before detaching or attaching wires and connectors. High current 28 VDC or 115 VAC is present. Failure to do so could result in death or serious injury.**

1. Check **NAV AIR DATA DC** (CB69) and **ECS ENG ANTI-ICE** (CB67) circuit breakers.  
**Do circuit breakers stay closed?**

YES	Go to step 2.
NO	To troubleshoot <b>NAV AIR DATA DC</b> circuit breaker, go to paragraph 12-56; To troubleshoot <b>ECS ENG ANTI-ICE</b> circuit breaker, go to paragraph 12-25 to troubleshoot engine anti-ice.

2. On pilot **ANTI ICE** panel, momentarily set **PITOT ICE DET AD SNSR** switch to **ON**. Check for 28 VDC between P872-A and P872-B.  
**Is voltage present?**

YES	Replace solenoid valve (TM 1-1520-238-23).
NO	Go to step 3.

3. Check for open between P872-A and P433-B1.  
**Does open exist?**

YES	Repair open wire. Go to paragraph 12-62.
NO	Go to step 4.

4. Check for open at P872-B.  
**Does open exist?**

YES	Repair open wire. Go to paragraph 12-62.
NO	Go to step 5.

5. Check for 28 VDC at P1-4.  
**Is voltage present?**

YES	Go to step 6.
NO	Go to paragraph 12-25 to troubleshoot engine anti-ice.

6. Check for 28 VDC between wire end (A402): XK5-10-X1 and XK5-10-X2.  
**Is voltage present?**

YES	Go to step 9.
NO	Go to step 7.

7. Check for open between wire end (A402): XK5-10-X1 and J20-B3.  
**Does open exist?**

YES	Repair open wire. Go to paragraph 12-62.
NO	Go to step 8.

---

**12-82. NO AIRFLOW THROUGH ICE DETECTOR SENSOR - (PITOT ICE  
DET AD SNSR SWITCH ON) (cont)**

---

12-82

8. Check for open between wire end  
(A402)XK5-10-X2 and ground.  
**Does open exist?**
- |     |  |
|-----|--|
| YES | Repair open wire.<br>Go to paragraph 12-62.              |
| NO  | Go to paragraph 12-56 to<br>troubleshoot Pitot anti-ice. |
9. Check for 28 VDC at wire end  
(A402)XK5-10-A2.  
**Is voltage present?**
- |     |   |
|-----|---|
| YES | Go to step 10.  |
| NO  | Repair open wire between P1-4<br>and (A402)XK5-10-A2.<br>Go to paragraph 12-62. |
10. Check for 28 VDC at (A402)XK5-10-A1.  
**Is voltage present?**
- |     |  |
|-----|--|
| YES | Repair open wire between<br>(A402):<br>XK5-10-A1 and J20-B1.<br>Go to paragraph 12-62. |
| NO  | Replace relay (A402)K5-10<br>(TM 1-1520-238-23).                                       |

END OF TASK

---

**12-83. ECS ICE DET HTR CIRCUIT BREAKER (CB212) - DOES NOT STAY CLOSED  
(PITOT ICE DET AD SNSR SWITCH OFF)**

---

12-83

**Tools:**

<u>Nomenclature</u>	<u>Part Number</u>
Tool Kit, Electrical Repairer's	SC518099CLA06
Extractor, Relay	CTJ-RO6
Multimeter, Digital	AN/PSM-45

**Personnel Required:**

68X Armament/Electrical Systems Repairer

**References:**

TM 1-1520-238-T-6

TM 1-1520-238-23

<b>WARNING</b>
----------------

**Turn off power before detaching or attaching wires and connectors. High current 28 VDC or 115 VAC is present. Failure to do so could result in death or serious injury.**

1. Check for short between (A402)J1-9 and ground.

**Does short exist?**

YES	Go to step 2.
NO	Refer to TM 1-1520-238-T-6 to troubleshoot circuit protection system (ac essential bus 2 - pilot station).

2. With relay (A402)K5-10 removed, check for short between relay case and (A402)K5-10-B2.

**Does short exist?**

YES	Replace relay (A402)K5-10 (TM 1-1520-238-23).
NO	Repair shorted wire between (A402): J1-9 and XK5-10-B2. Go to paragraph 12-62.

END OF TASK

**12-84. ECS ICE DET HTR CIRCUIT BREAKER (CB212) - DOES NOT STAY CLOSED  
(PITOT ICE DET AD SNSR SWITCH ON)**

**Tools:**

<u>Nomenclature</u>	<u>Part Number</u>
Tool Kit, Electrical Repairer's	SC518099CLA06
Extractor, Relay	CTJ-RO6
Multimeter, Digital	AN/PSM-45

**Personnel Required:**

68X Armament/Electrical Systems Repairer

**References:**

TM 1-1520-238-23

**Equipment Conditions:**

<u>Ref</u>	<u>Condition</u>
TM 1-1520-238-23	Electrical power distribution box cover removed

**WARNING**

**Turn off power before detaching or attaching wires and connectors. High current 28 VDC or 115 VAC is present. Failure to do so could result in death or serious injury.**

1. Remove relay (A402)K5-10. Check for short between relay case and (A402)K5-10-B2.

**Does short exist?**

- |     |   |
|-----|---|
| YES | Replace relay (A402)K5-10 (TM 1-1520-238-23). |
| NO  | Go to step 2.                                 |

2. Detach P690. Check for short between (A402)XK5-10-B1 and ground.

**Does short exist?**

- |     |   |
|-----|---|
| YES | Repair shorted wire between: P433-B2 and P690-6. (A402): J1-9 and XK5-10-B2, J20-B2 and XK5-10-B1, Go to paragraph 12-62. |
| NO  | Replace ice detector sensor (TM 1-1520-238-23).   |

END OF TASK

12-85. WINDSHIELD WIPERS - POWER UP

12-85

**Tools:**

Nomenclature	Part Number
Tool Kit, Aircraft Mechanic's	SC518099CLA01

**Personnel Required:**

68X Armament/Electrical Systems Repairer

**References:**

TM 55-1520-238-23

**Equipment Conditions:**

Ref	Condition
TM 55-1520-238-23	Helicopter safed External power application - Electrical - Pressurized air Windshield wiper system inspection completed

**NOTE**

Refer to pilot station (fig. 12-71) and CPG station (fig. 12-72) for cockpit configuration and equipment.

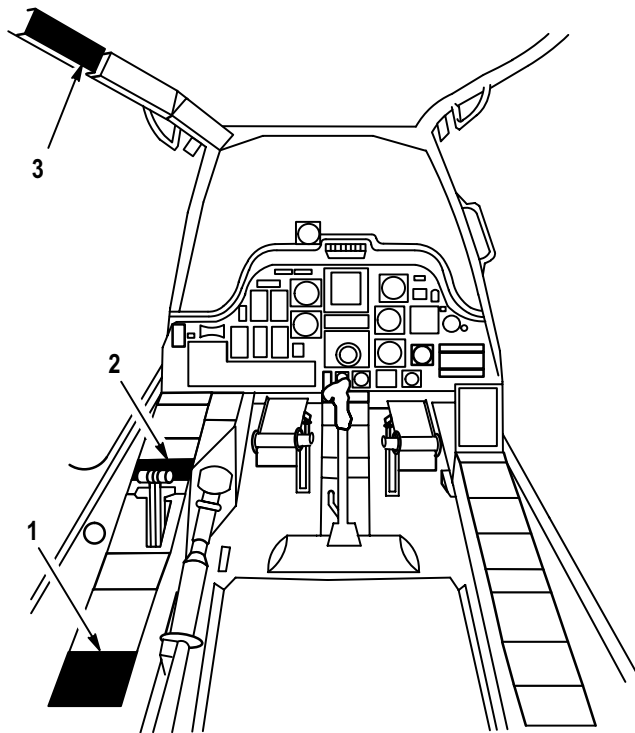

- 1. PILOT ANTI ICE PANEL
- 2. PILOT ELEC PWR PANEL
- 3. PILOT AFT CIRCUIT PANEL

M71-068

**Figure 12-71. Pilot Station**

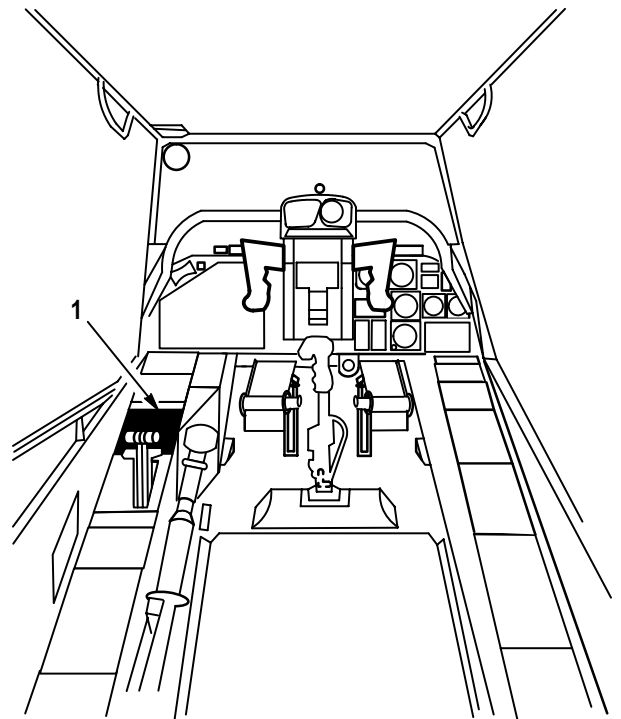

- 1. CPG AUX / ANTI - ICE PANEL

M71-069

**Figure 12-72. CPG Station**

- 1. On pilot aft circuit breaker panel (fig. 12-73), check that **ECS WSHLD WPR** circuit breaker is open.

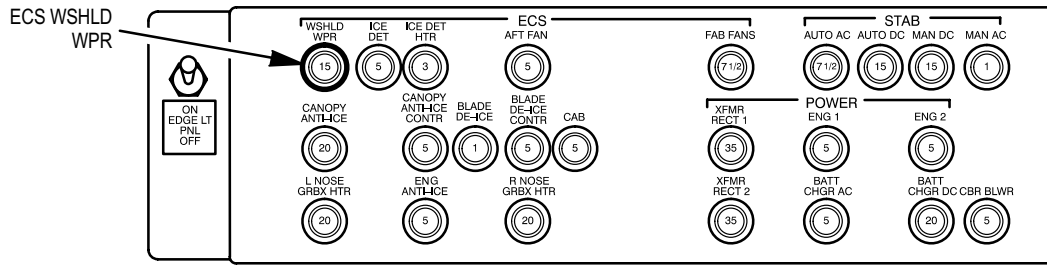

M71-070

Figure 12-73. Pilot Aft Circuit Breaker Panel

2. On CPG AUX/ANTI-ICE panel (fig. 12-74), check that **W WIPER** switch is set to **PLT**.

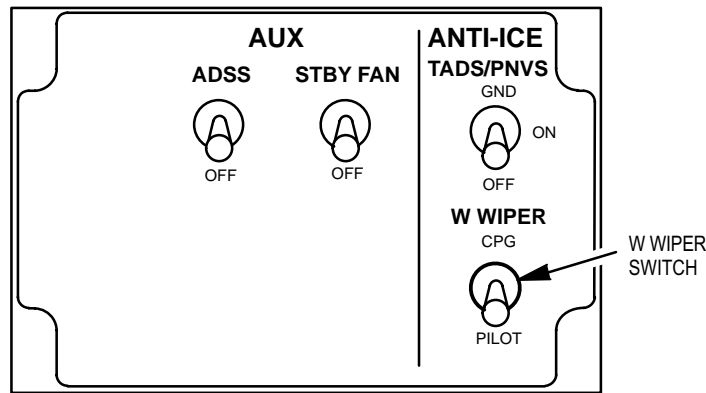

M71-071

Figure 12-74. CPG AUX/ANTI-ICE Panel

3. On pilot **ELEC PWR** panel (fig. 12-75), set **BATT/EXT PWR** switch to **EXT PWR**.

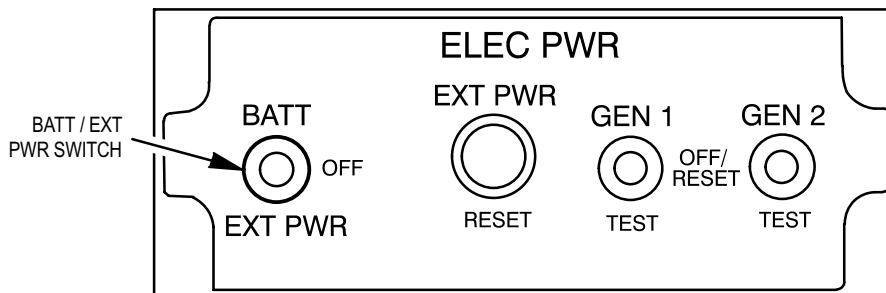

M71-072

Figure 12-75. Pilot ELEC PWR Panel

END OF TASK



---

**12-86. WINDSHIELD WIPERS - POWER DOWN**

---

**12-86****Tools:**NomenclaturePart NumberTool Kit, Aircraft  
Mechanic's

SC518099CLA01

**References:**

TM 55-1520-238-23

**Equipment Conditions:****Personnel Required:**

68X Armament/Electrical Systems Repairer

Ref

Paragraph 12-85

ConditionWINDSHIELD WIPERS -  
POWER UP completed

---

**NOTE****Refer to pilot station (fig. 12-71) and CPG station (fig. 12-72) for cockpit configuration and equipment.**

1. On pilot aft circuit breaker panel (fig. 12-73), open **ECS WSHLD WPR** circuit breaker.
2. On pilot **ELEC PWR** panel (fig. 12-75), set **BATT/EXT PWR** switch to **OFF**.
3. Remove external power - electrical and pressurized air (TM 55-1520-238-23).

END OF TASK

12-87. WINDSHIELD WIPERS - MAINTENANCE OPERATIONAL CHECK

12-87

**Tools:**

Nomenclature

Tool Kit, Electrical  
Repairer's

Part Number

SC518099CLA06

**References:**

TM 55-1520-238-23

**Equipment Conditions:**

Ref

Paragraph 12-85

Condition

WINDSHIELD WIPERS -  
POWER UP completed

**Personnel Required:**

68X Armament/Electrical Systems Repairer  
One person to assist

**NOTE**

- Refer to pilot station (fig. 12-71) and CPG station (fig. 12-72) for cockpit configuration and equipment.
- If referenced out of one paragraph or volume into another for additional troubleshooting, upon completion of the task, return to the maintenance operational check for the original paragraph or volume.

**NOTE**

Wash pilot and CPG windshields (fig. 12-76) with distilled or fresh, clean water before operating windshield wipers.

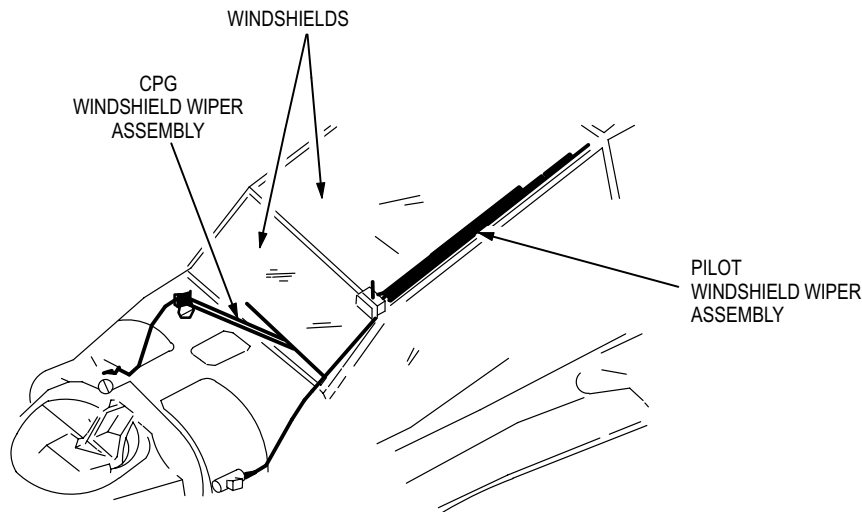

M71-074

Figure 12-76. Windshield Wipers

**12-87. WINDSHIELD WIPERS - MAINTENANCE OPERATIONAL CHECK (cont)**

**12-87**

1. Perform the maintenance operational check as follows:

Task	Result
<p>a. On pilot aft circuit breaker panel (fig. 12-73), check that <b>ECS WSHLD WPR</b> circuit breaker is open. On pilot <b>ANTI ICE</b> panel (fig. 12-77), check that <b>WSHLD WIPER</b> switch is set to <b>OFF</b>. On CPG <b>AUX/ANTI-ICE</b> panel (fig. 12-74), check that <b>W WIPER</b> switch is set to <b>PLT</b>.</p>	
	
<p><b>Keep pilot and CPG windshields wet with distilled or fresh, clean water while operating windshield wipers to prevent scratches.</b></p>	
<p>b. Close <b>ECS WSHLD WPR</b> circuit breaker. Set pilot <b>WSHLD WIPER</b> switch to <b>LOW</b>.</p>	<p>If <b>ECS WSHLD WPR</b> circuit breaker does not stay closed, go to paragraph 12-89.</p>
	<p>If pilot windshield wiper does not operate at low speed, go to paragraph 12-90.</p>
	<p>If CPG windshield wiper does not operate at low speed, go to paragraph 12-91.</p>
<p>c. Set pilot <b>WSHLD WIPER</b> switch to <b>HIGH</b>.</p>	<p>If pilot windshield wiper does not operate at high speed, go to paragraph 12-92.</p>
	<p>If CPG windshield wiper does not operate at high speed, go to paragraph 12-93.</p>
<p>d. Hold pilot <b>WSHLD WIPER</b> switch at <b>PARK</b>.</p>	<p>If windshield wipers do not stop in parked position, note where they do stop.</p>
<p>e. Set pilot <b>WSHLD WIPER</b> switch to <b>LOW</b>.</p>	
<p>f. Hold pilot <b>WSHLD WIPER</b> switch at <b>PARK</b>.</p>	

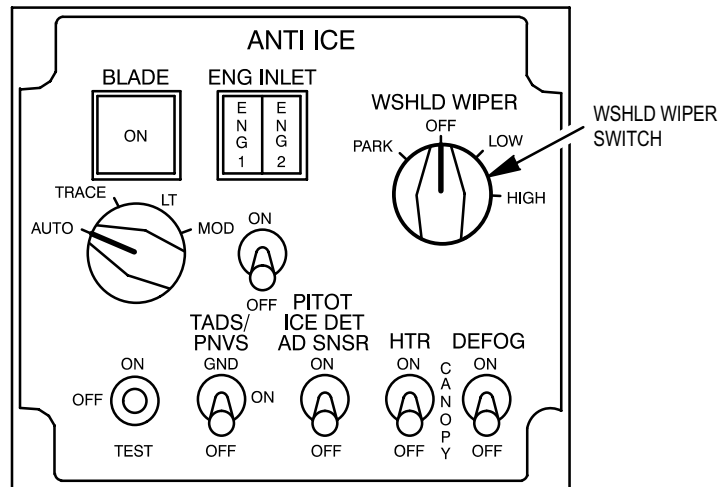

M71-073

Figure 12-77. Pilot ANTI ICE Panel

Task	Result
<p>g. On pilot <b>ANTI ICE</b> panel (fig. 12-77), release pilot <b>WSHLD WIPER</b> switch, allowing it to return to <b>OFF</b>.</p>	<p>If pilot windshield wiper stops in a position different than noted in step d., go to paragraph 12-94.</p> <p>If CPG windshield wiper stops in a position different than noted in step d., go to paragraph 12-95.</p> <p>If pilot windshield wiper stops in same position as in step d. but not in parked position, align pilot wiper blade (TM 55-1520-238-23).</p> <p>If CPG windshield wiper stops in same position as in step d. but not in parked position, align CPG wiper blade (TM 55-1520-238-23).</p>
<p>h. On CPG <b>AUX/ANTI-ICE</b> panel, set CPG <b>W WIPER</b> switch to <b>CPG</b>.</p>	<p>If CPG windshield wiper does not operate at low speed, go to paragraph 12-96.</p>
<p>i. Set CPG <b>W WIPER</b> switch to <b>PLT</b>. Hold pilot <b>WSHLD WIPER</b> switch at <b>PARK</b>, then release the switch, allowing it to return to <b>OFF</b>.</p>	<p>If CPG windshield wiper does not stop in parked position, go to paragraph 12-95.</p>

2. Perform WINDSHIELD WIPERS - POWER DOWN (para 12-86).

END OF TASK

12-88. WINDSHIELD WIPERS - WIRING INTERCONNECT DIAGRAM

12-88

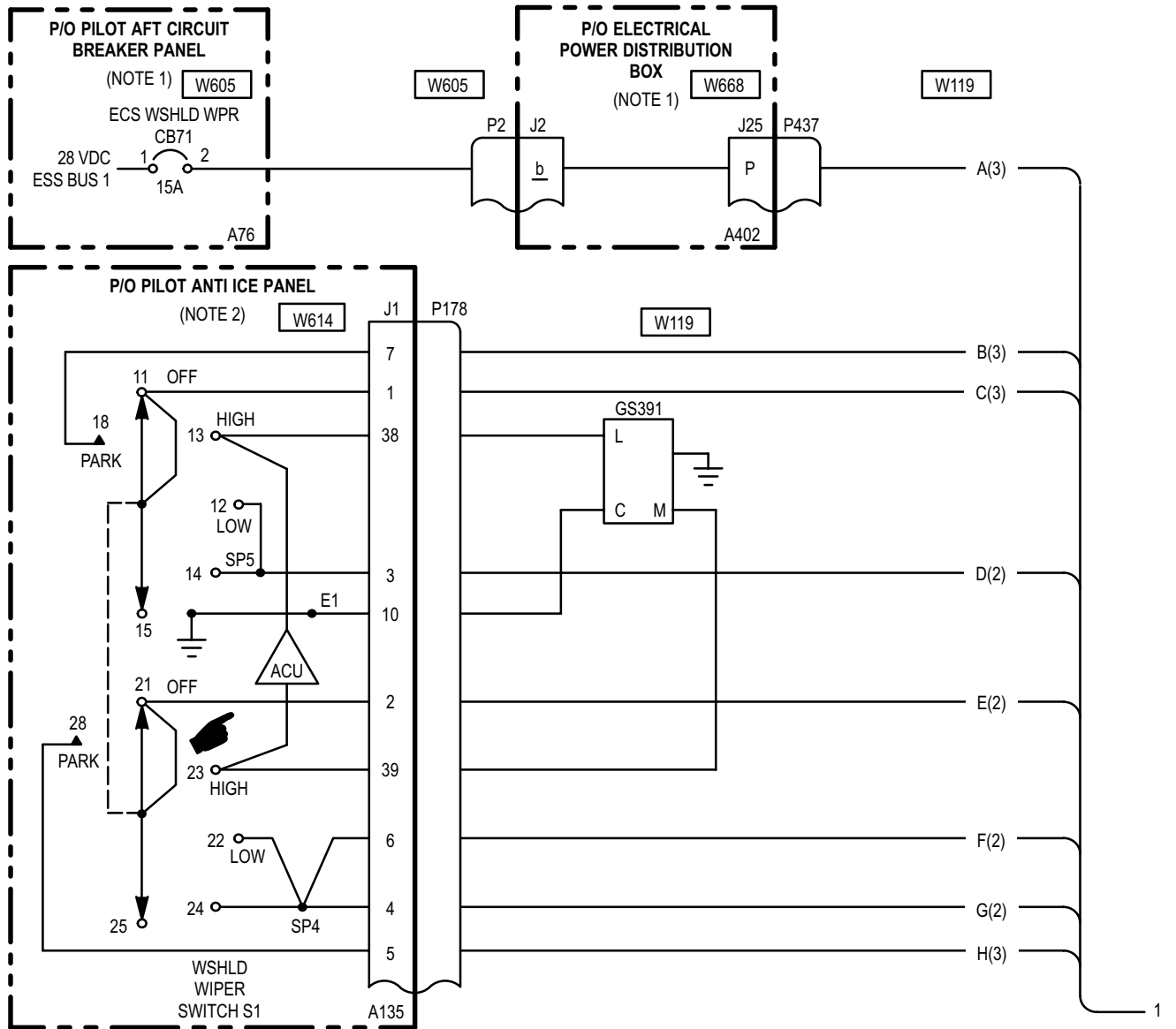

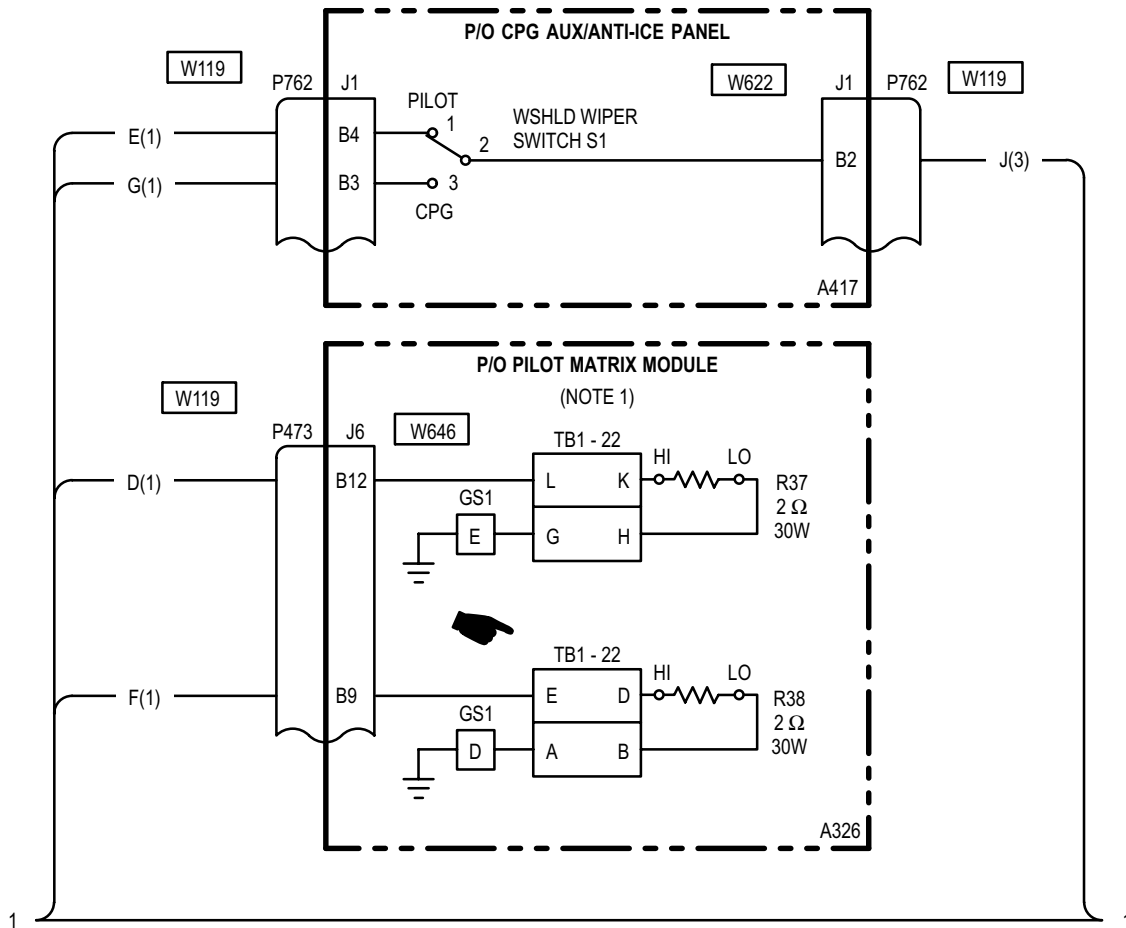

12-88. WINDSHIELD WIPERS - WIRING INTERCONNECT DIAGRAM (cont)

NOTES:

HIGHWAY USE: THE ALPHA CHARACTER IDENTIFIES A SPECIFIC LINE, AND THE NUMBER IN PARENTHESIS IDENTIFIES THE SHEET NUMBER WHERE THE SIGNAL TERMINATES.

1. ELECTRICAL SYSTEM (TM 1-1520-238-T-6).

2.

CONTACT	PILOT W/S WIPER SWITCH POSITION		
	LOW	HIGH	PARK
11 - 12	X		
11 - 13		X	
11 - 18			X
21 - 22	X		
21 - 23		X	
21 - 28			X
X - INDICATES CONTACTS CLOSED			

3. HS DESIGNATES A HARD SPLICE WHICH MAY NOT BE DISCONNECTED. M DESIGNATES A SOFT SPLICE WHICH MAY BE DISCONNECTED FOR A WIRING CHECK.

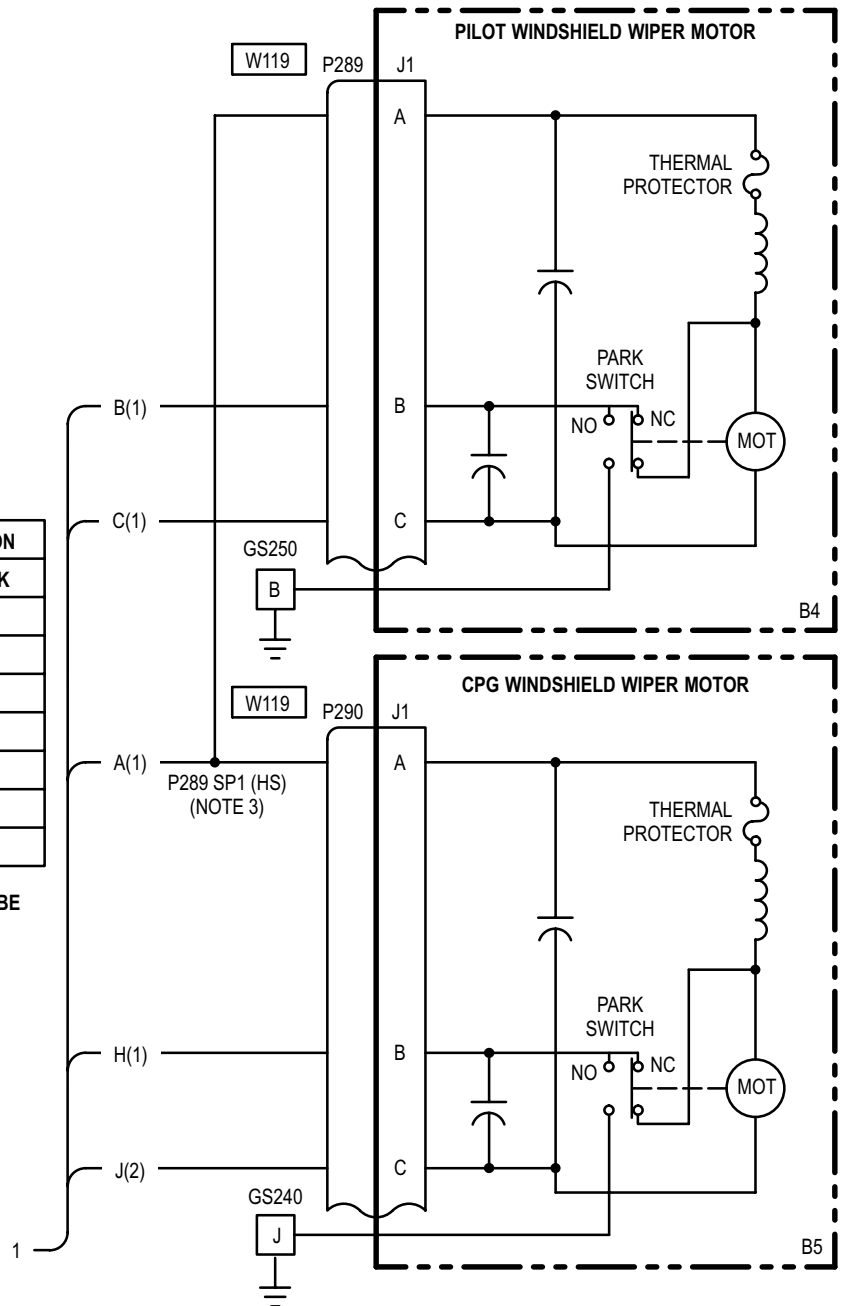

**12-89. ECS WSHLD WPR CIRCUIT BREAKER (CB71) - DOES NOT STAY CLOSED**

**12-89**

**Tools:**

<u>Nomenclature</u>	<u>Part Number</u>
Tool Kit, Electrical Repairer's	SC518099CLA06
Multimeter, Digital	AN/PSM-45

**Personnel Required:**

68X Armament/Electrical Systems Repairer

**References:**

TM 1-1520-238-T-6  
 TM 55-1520-238-23



**Turn off power before detaching or attaching wires and connectors. High current 28 VDC or 115 VAC is present. Failure to do so could result in death or serious injury.**

1. On pilot **ANTI ICE** panel, set **WSHLD WIPER** switch to **OFF**. Check for short between (A402)J2-b and ground.  
**Does short exist?**
  - YES      Go to step 2.
  - NO      Refer to TM 1-1520-238-T-6 to troubleshoot circuit protection system (dc essential bus 1 - pilot station).
  
2. Detach P289. Check for short between (A402)J2-b and ground.  
**Does short exist?**
  - YES      Go to step 3.
  - NO      Replace pilot windshield wiper motor (TM 55-1520-238-23).

3. Detach P290. Check for short between (A402)J2-b and ground.  
**Does short exist?**
  - YES      Go to step 4.
  - NO      Replace CPG windshield wiper motor (TM 55-1520-238-23).
  
4. Detach P437. Check for short between (A402)J2-b and ground.  
**Does short exist?**
  - YES      Repair shorted wire between (A402): J2-b and J25-P. Go to paragraph 12-87.
  - NO      Repair shorted wire between: P437-P and P289-A, P437-P and P290-A. Go to paragraph 12-87.

END OF TASK



**12-90. PILOT WINDSHIELD WIPER - DOES NOT OPERATE AT LOW SPEED**

**12-90**

**Tools:**

<u>Nomenclature</u>	<u>Part Number</u>
Tool Kit, Electrical Repairer's	SC518099CLA06
Multimeter, Digital	AN/PSM-45

**Personnel Required:**

68X Armament/Electrical Systems Repairer  
One person to assist

**References:**

TM 1-1520-238-T-6  
TM 55-1520-238-23



**Turn off power before detaching or attaching wires and connectors. High current 28 VDC or 115 VAC is present. Failure to do so could result in death or serious injury.**



**Keep pilot and CPG windshields wet with fresh, clean water while operating windshield wipers to prevent scratches.**

- On pilot **ANTI ICE** panel, set **WSHLD WIPER** switch to **LOW**. On CPG **AUX/ANTI-ICE** panel, check that **W WIPER** switch is set to **PLT**. Listen for pilot windshield wiper motor operation.

**Is wiper motor operating?**

- YES Go to step 7.
- NO Go to step 2.

- Detach P178. Check for open between (A135): J1-1 and J1-3.

**Does open exist?**

- YES Replace pilot **ANTI ICE** panel (TM 55-1520-238-23).
- NO Go to step 3.

- Attach P178. Check for 28 VDC at P289-A.  
**Is voltage present?**

- YES Go to step 5.
- NO Go to step 4.

- Check for 28 VDC at P2-b.  
**Is voltage present?**

- YES Repair open wire between: P289-A and P289 SP1, P289-SP1 and P437-P. (A402): J25-P and J2-b. Go to paragraph 12-87.

- NO Refer to TM 1-1520-238-T-6 to troubleshoot circuit protection system (dc essential bus 1 - pilot station).

- Check for open between: P289-C and P178-1, P178-3 and P473-B12. (A326):

J6-B12 and TB1-22-L, TB1-22-G and ground.

**Does open exist?**

- YES Repair open wire. Go to paragraph 12-87.
- NO Go to step 6.

- Detach P473. Check for 2 ohms resistance between (A326): TB1-22-K and TB1-22-H.

**Is resistance present?**

- YES Replace pilot windshield wiper motor (TM 55-1520-238-23).
- NO Replace resistor (A326)R37 (TM 55-1520-238-23).

---

**12-90. PILOT WINDSHIELD WIPER - DOES NOT OPERATE AT LOW SPEED (cont)**

---

**12-90**

7. Set pilot **WSHLD WIPER** switch to **OFF**. Detach pilot windshield wiper flexdrive from converter (TM 55-1520-238-23). Set **WSHLD WIPER** switch to **LOW**.

**Is flexdrive cable rotating?**

- |     |   |
|-----|---|
| YES | Replace pilot windshield wiper converter (TM 55-1520-238-23). |
| NO  | Replace pilot windshield wiper flexdrive (TM 55-1520-238-23). |

END OF TASK

**12-91. CPG WINDSHIELD WIPER - DOES NOT OPERATE AT LOW SPEED**

**12-91**

**Tools:**

<u>Nomenclature</u>	<u>Part Number</u>
Tool Kit, Electrical Repairer's	SC518099CLA06
Multimeter, Digital	AN/PSM-45

**Personnel Required:**

68X Armament/Electrical Systems Repairer  
One person to assist

**References:**

TM 1-1520-238-T-6  
TM 55-1520-238-23  
TM 9-1230-476-20-1

**Equipment Conditions:**

<u>Ref</u>	<u>Condition</u>
TM 55-1520-238-23	Access provisions - R40 cover removed
TM 9-1230-476-20-1	MRTU type III - removed

**WARNING**

**Turn off power before detaching or attaching wires and connectors. High current 28 VDC or 115 VAC is present. Failure to do so could result in death or serious injury.**

- On pilot **ANTI ICE** panel, set **WSHLD WIPER** switch to **LOW**. On CPG **AUX/ANTI-ICE** panel, check that **W WIPER** switch is set to **PILOT**. Listen for CPG windshield wiper motor operation.

**Does open exist?**

- |     |               |
|-----|---------------|
| YES | Go to step 2. |
| NO  | Go to step 3. |

- Set **WSHLD WIPER** switch to **OFF**. Detach CPG windshield wiper flexdrive from converter (TM 55-1520-238-23). Set **WSHLD WIPER** switch to **LOW**.

**Is flexdrive cable rotating?**

- |     |   |
|-----|---|
| YES | Replace CPG windshield wiper converter (TM 55-1520-238-23). |
| NO  | Replace CPG windshield wiper flexdrive (TM 55-1520-238-23). |

- Detach P178. Check for open between (A135): J1-2 and J1-6.

**Does open exist?**

- |     |  |
|-----|--|
| YES | Replace pilot <b>ANTI ICE</b> panel (TM 55-1520-238-23). |
| NO  | Go to step 4.  |

- Attach P178. Detach P762. Check for open between (A417): J1-B2 and J1-B4.

**Does open exist?**

- |     |  |
|-----|--|
| YES | Replace CPG <b>AUX/ANTI-ICE</b> panel (TM 55-1520-238-23). |
| NO  | Go to step 5.  |

- Attach P762. Check for 28 VDC at P290-A.

**Is voltage present?**

- |     |               |
|-----|---------------|
| YES | Go to step 7. |
| NO  | Go to step 6. |

- Check for 28 VDC at P2-b.

**Is voltage present?**

- |     |  |
|-----|--|
| YES | Repair open wire between: P290-A and P437-P. (A402): J25-P and J2-b. Go to paragraph 12-87.                |
| NO  | Refer to TM 1-1520-238-T-6 to troubleshoot circuit protection system (dc essential bus 1 - pilot station). |

---

**12-91. CPG WINDSHIELD WIPER - DOES NOT OPERATE AT LOW SPEED (cont)**

---

**12-91**

## 7. Check for open between:

P290-C and P762-B2,  
P762-B4 and P178-2,  
P178-6 and P473-B9.

(A326):

J6-B9 and TB1-22-E,  
TB1-22-A and ground.

**Does open exist?**

YES        Repair open wire.  
              Go to paragraph 12-87.

NO         Go to step 9.

## 8. Check for 2 ohms between (A326):

TB1-22-B and TB1-22-D.

**Is resistance present?**

YES        Replace CPG windshield wiper  
              motor (TM 55-1520-238-23).

NO         Replace resistor (A326)R38  
              (TM 55-1520-238-23).

END OF TASK

---

**12-92. PILOT WINDSHIELD WIPER - DOES NOT OPERATE AT HIGH SPEED**

---

12-92

**Tools:**

<u>Nomenclature</u>	<u>Part Number</u>
Tool Kit, Electrical Repairer's	SC518099CLA06
Multimeter, Digital	AN/PSM-45

**Personnel Required:**

68X Armament/Electrical Systems Repairer

**References:**TM 55-1520-238-23

---

**WARNING**

**Turn off power before detaching or attaching wires and connectors. High current 28 VDC or 115 VAC is present. Failure to do so could result in death or serious injury.**

On pilot **ANTI ICE** panel, set **WSHLD WIPER** switch to **HIGH**. Detach P178. Check for open between (A135):  
J1-1 and J1-38.

**Does open exist?**

- |     |   |
|-----|---|
| YES | Replace pilot <b>ANTI ICE</b> panel (TM 55-1520-238-23).                |
| NO  | Repair open wire between P178-38 and GS391-L.<br>Go to paragraph 12-87. |

END OF TASK

---

**12-93. CPG WINDSHIELD WIPER - DOES NOT OPERATE AT HIGH SPEED**

---

12-93

**Tools:**

<u>Nomenclature</u>	<u>Part Number</u>
Tool Kit, Electrical Repairer's	SC518099CLA06
Multimeter, Digital	AN/PSM-45

**Personnel Required:**

68X Armament/Electrical Systems Repairer

**References:**TM 55-1520-238-23

---

<b>WARNING</b>
----------------

**Turn off power before detaching or attaching wires and connectors. High current 28 VDC or 115 VAC is present. Failure to do so could result in death or serious injury.**

On pilot **ANTI ICE** panel, set **WSHLD WIPER** switch to **HIGH**. Detach P178. Check for open between (A135):  
J1-2 and J1-39.

**Does open exist?**

- |     |   |
|-----|---|
| YES | Replace pilot <b>ANTI ICE</b> panel (TM 55-1520-238-23).                |
| NO  | Repair open wire between P178-39 and GS391-M.<br>Go to paragraph 12-87. |

END OF TASK

**12-94. PILOT WINDSHIELD WIPER - DOES NOT STOP IN PARKED POSITION****12-94****Tools:**

<u>Nomenclature</u>	<u>Part Number</u>
Tool Kit, Electrical Repairer's	SC518099CLA06
Multimeter, Digital	AN/PSM-45

**Personnel Required:**

68X Armament/Electrical Systems Repairer

**References:**

TM 55-1520-238-23

**WARNING**

**Turn off power before detaching or attaching wires and connectors. High current 28 VDC or 115 VAC is present. Failure to do so could result in death or serious injury.**

1. On pilot **ANTI ICE** panel, set **WSHLD WIPER** switch to **PARK**. Detach P178. Check for open between (A135):

J1-1 and J1-7.

**Does open exist?**

YES	Replace pilot <b>ANTI ICE</b> panel (TM 55-1520-238-23).
-----	--

NO	Go to step 2.
----	---------------

2. Check for open between P178-7 and P289-B.

**Does open exist?**

YES	Repair open wire. Go to paragraph 12-87.
-----	---

NO	Replace pilot windshield wiper motor (TM 55-1520-238-23).
----	---

END OF TASK

**12-95. CPG WINDSHIELD WIPER - DOES NOT STOP IN PARKED POSITION**

12-95

**Tools:**

<u>Nomenclature</u>	<u>Part Number</u>
Tool Kit, Electrical Repairer's	SC518099CLA06
Multimeter, Digital	AN/PSM-45

**Personnel Required:**

68X Armament/Electrical Systems Repairer

**References:**

TM 55-1520-238-23

<b>WARNING</b>
----------------

**Turn off power before detaching or attaching wires and connectors. High current 28 VDC or 115 VAC is present. Failure to do so could result in death or serious injury.**

1. On pilot **ANTI ICE** panel, set **WSHLD WIPER** switch to **PARK**. Detach P178. Check for open between (A135):  
J1-2 and J1-5.

**Does open exist?**

YES	Replace pilot <b>ANTI ICE</b> panel (TM 55-1520-238-23).
NO	Go to step 2.

2. Check for open between P178-5 and P290-B.

**Does open exist?**

YES	Repair open wire. Go to paragraph 12-87.
NO	Replace CPG windshield wiper motor (TM 55-1520-238-23).

END OF TASK



---

**12-96. CPG WINDSHIELD WIPER - DOES NOT OPERATE AT LOW SPEED  
UNDER CPG CONTROL**

---

12-96

**Tools:**

<u>Nomenclature</u>	<u>Part Number</u>
Tool Kit, Electrical Repairer's	SC518099CLA06
Multimeter, Digital	AN/PSM-45

**Personnel Required:**

68X Armament/Electrical Systems Repairer

**References:**

TM 55-1520-238-23

<b>WARNING</b>
----------------

**Turn off power before detaching or attaching wires and connectors. High current 28 VDC or 115 VAC is present. Failure to do so could result in death or serious injury.**

1. On CPG **AUX/ANTI-ICE** panel, set **W WIPER** switch to **CPG**. Detach P762. Check for open between (A417):

J1-B2 and J1-B3.

**Does open exist?**

YES	Replace CPG <b>AUX/ANTI-ICE</b> panel (TM 55-1520-238-23).
NO	Go to step 2.

2. Check for open between P762-B3 and P178-4.

**Does open exist?**

YES	Repair open wire. Go to paragraph 12-87.
NO	Replace pilot <b>ANTI ICE</b> panel (TM 55-1520-238-23).

END OF TASK

12-97. ENGINE 1 FIRE DETECTION - POWER UP

12-97

**Tools:**

Nomenclature	Part Number
Tool Kit, Aircraft Mechanic's	SC518099CLA01

**Personnel Required:**

68X Armament/Electrical Systems Repairer

**References:**

TM 1-1520-238-23

**Equipment Conditions:**

Ref	Condition
TM 1-1520-238-23	Helicopter safed External power application - Electrical Engine 1 fire detection system inspection completed

**NOTE**

Refer to pilot station (fig. 12-78) and CPG station (fig. 12-79) for cockpit configuration and equipment.

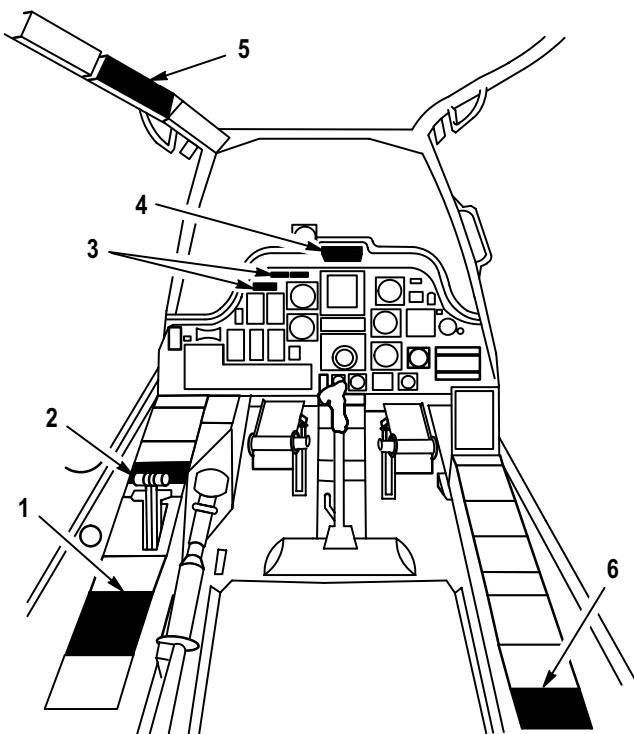

1. PILOT EXT LT/INTR LT PANEL
2. PILOT ELEC PWR PANEL
3. PILOT FIRE EXTINGUISHER PANEL
4. PILOT MASTER CAUTION/WARNING PANEL
5. PILOT CENTER CIRCUIT BREAKER PANEL
6. PILOT APU FIRE TEST PANEL

M71-081A

**Figure 12-78. Pilot Station**

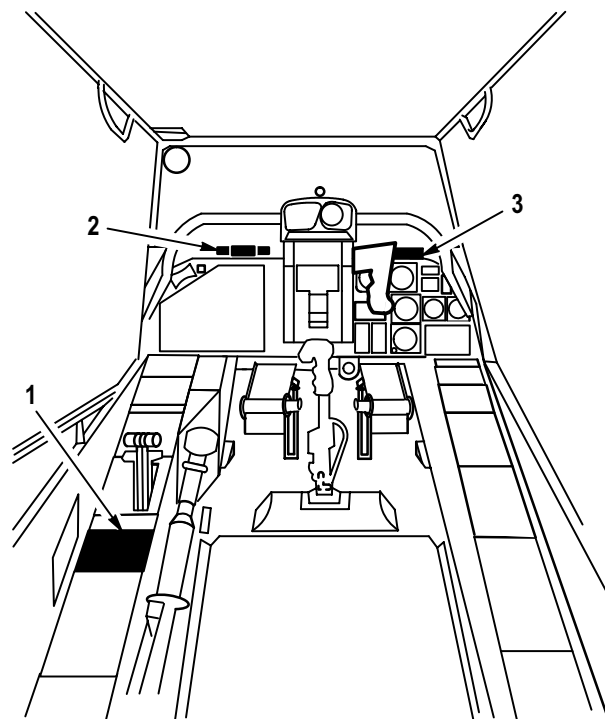

1. CPG INTR LT PANEL
2. CPG GLARESHIELD FIRE EXTINGUISHER PANEL
3. CPG MASTER CAUTION/WARNING PANEL

M71-082

**Figure 12-79. CPG Station**

12-97. ENGINE 1 FIRE DETECTION - POWER UP (cont)

12-97

1. On pilot center circuit breaker panel (fig. 12-80), check that the following circuit breakers are closed:

Circuit Breaker

**FIRE DETR ENG 1**

**LT PRI**

**LT CAUT**

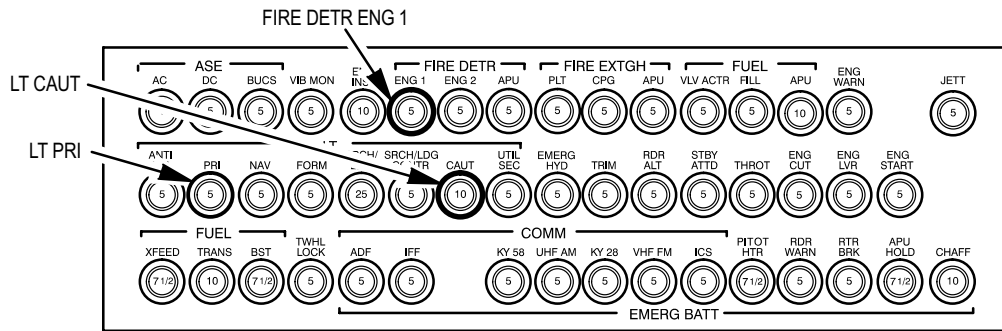

M71-083

Figure 12-80. Pilot Center Circuit Breaker Panel

2. On pilot ELEC PWR panel (fig. 12-81), set BATT/EXT PWR switch to EXT PWR.

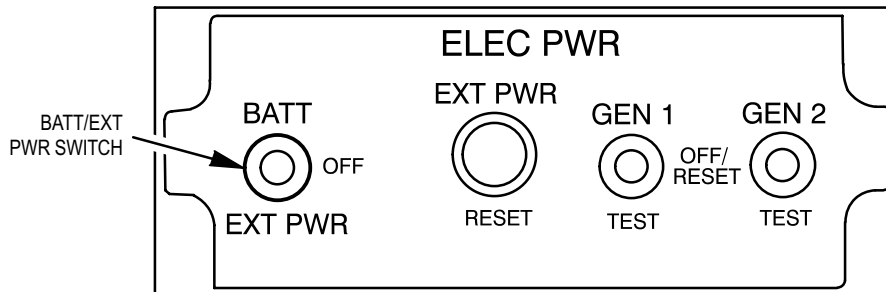

M71-084

Figure 12-81. Pilot ELEC PWR Panel

END OF TASK

**12-98. ENGINE 1 FIRE DETECTION - POWER DOWN****12-98****Tools:**NomenclaturePart NumberTool Kit, Electrical  
Repairer's

SC518099CLA06

**References:**

TM 1-1520-238-23

**Equipment Conditions:**Ref

Paragraph 12-97

ConditionENGINE 1 FIRE  
DETECTION - POWER  
UP completed**Personnel Required:**

68X Armament/Electrical Systems Repairer

**NOTE**

**Refer to pilot station (fig. 12-78) and CPG station (fig. 12-79) for cockpit configuration and equipment.**

1. On pilot center circuit breaker panel (fig. 12-80), open the following circuit breakers.

Circuit Breaker**FIRE DETR ENG 1****LT PRI****LT CAUT**

2. On pilot **ELEC PWR** panel (fig. 12-81), set **BATT/EXT PWR** switch to **OFF**.
3. Remove external power - electrical (TM 1-1520-238-23).

END OF TASK

**12-99. ENGINE 1 FIRE DETECTION - MAINTENANCE OPERATIONAL CHECK**

**12-99**

**Tools:**

<u>Nomenclature</u>	<u>Part Number</u>
Tool Kit, Electrical Repairer's	SC518099CLA06
Multimeter, Digital	AN/PSM-45

**Equipment Conditions:**

<u>Ref</u>	<u>Condition</u>
TM 55-1520-238-23	Access provisions - LN1 door opened
Paragraph 12-97	ENGINE 1 FIRE DETECTION - POWER UP completed
TM 1-1520-238-T-4	Maintenance headset connected

**Personnel Required:**

68X Armament/Electrical Systems Repairer  
One person to assist

**References:**

TM 1-1520-238-T-4  
TM 55-1520-238-23

**NOTE**

- Refer to pilot station (fig. 12-78) and CPG station (fig. 12-79) for cockpit configuration and equipment.
- If referenced out of one paragraph or volume into another for additional troubleshooting, upon completion of the task, return to the maintenance operational check for the original paragraph or volume.

1. Perform the maintenance operational check as follows:

<u>Task</u>	<u>Result</u>
a. On pilot <b>EXT LT/INTR LT</b> panel (fig. 12-82), rotate <b>INST</b> control between <b>OFF</b> and <b>BRT</b> .	If pilot fire extinguisher panel edge-light (fig. 12-83) does not brighten, go to paragraph 12-101.
b. On CPG <b>INTR LT</b> panel (fig. 12-84), rotate <b>INST</b> control between <b>OFF</b> and <b>BRT</b> .	If CPG fire extinguisher panel edge-light (fig. 12-85) does not brighten, go to paragraph 12-102.
c. On pilot master caution/warning panel (fig. 12-86), press and hold the <b>PRESS TO TEST</b> switch.	If pilot <b>ENG 1 FIRE PULL</b> handle (fig. 12-83) does not light, replace lamp (TM 55-1520-238-23). If lamp is still not lighted, go to paragraph 12-104.

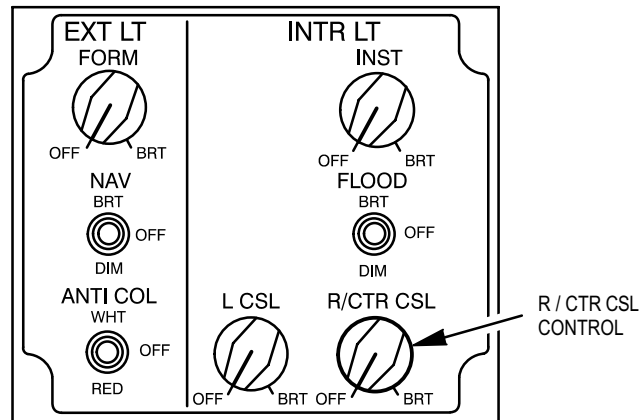

M71-087

Figure 12-82. Pilot EXT LT/INTR LT Panel

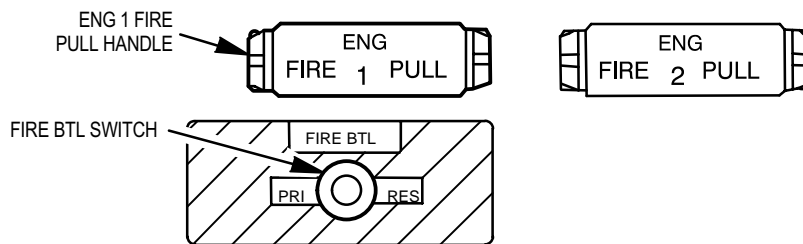

M71-086

Figure 12-83. Pilot Fire Extinguisher Panel

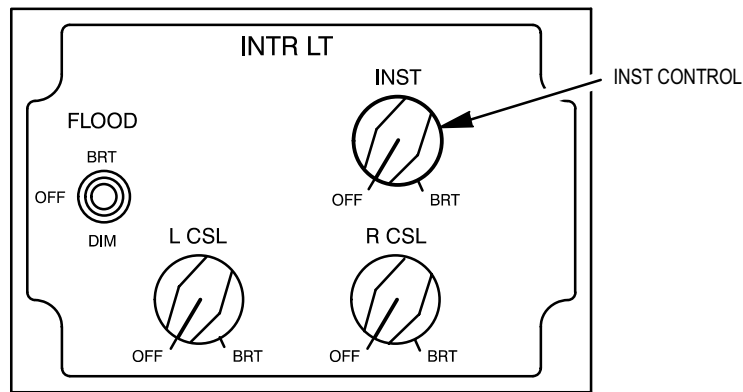

M71-088

Figure 12-84. CPG INTR LT Panel

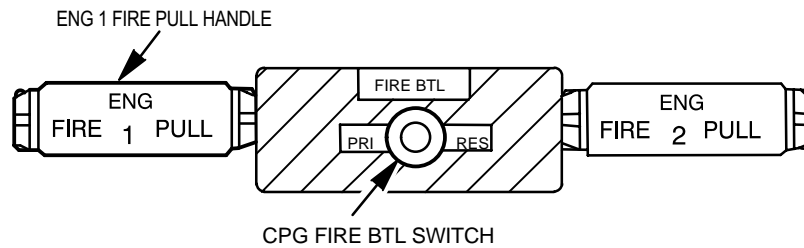

M71-089

Figure 12-85. CPG Fire Extinguisher Panel

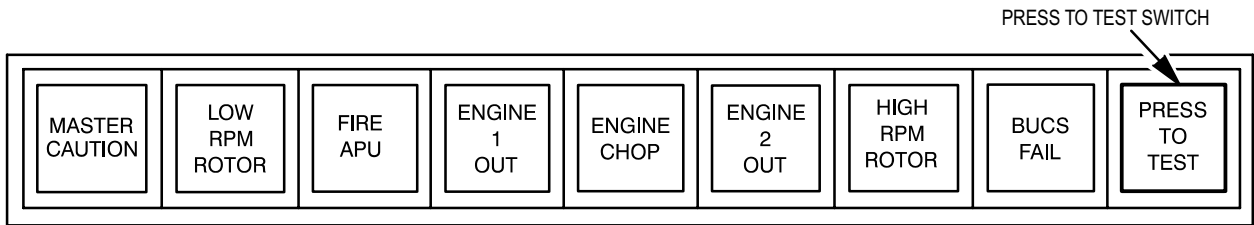

M71-090

Figure 12-86. Master Caution/Warning Panel

Task	Result
d. On CPG master caution/warning panel (fig. 12-86), press and hold the <b>PRESS TO TEST</b> switch.	If CPG <b>ENG 1 FIRE PULL</b> handle (fig. 12-85) does not light, replace lamp (TM 55-1520-238-23). If lamp still does not light, go to paragraph 12-105.
e. On pilot <b>APU</b> fire test panel (fig. 12-87), hold <b>FIRE TEST DET</b> switch at <b>1</b> .	If pilot and CPG <b>ENG 1 FIRE PULL</b> handles do not light, go to paragraph 12-106.
f. Hold <b>FIRE TEST DET</b> switch at <b>2</b> .	If pilot and CPG <b>ENG 1 FIRE PULL</b> handles do not light, go to paragraph 12-107.
g. Release <b>FIRE TEST DET</b> switch, allowing it to return to <b>OFF</b> .	

**NOTE**

**Place helicopter in shade or indoors during operational check of flame detectors.**

- h. Cover engine 1 lower flame detector lens with a rag.
  - i. Shine flashlight with a red filter on engine 1 upper flame detector lens (fig. 12-88).
- If pilot and CPG **ENG 1 FIRE PULL** handles do not light, go to paragraph 12-108.

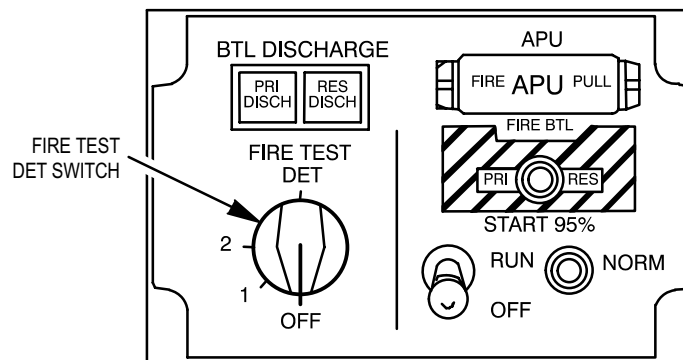

M71-091A

Figure 12-87. Pilot APU Fire TestPanel

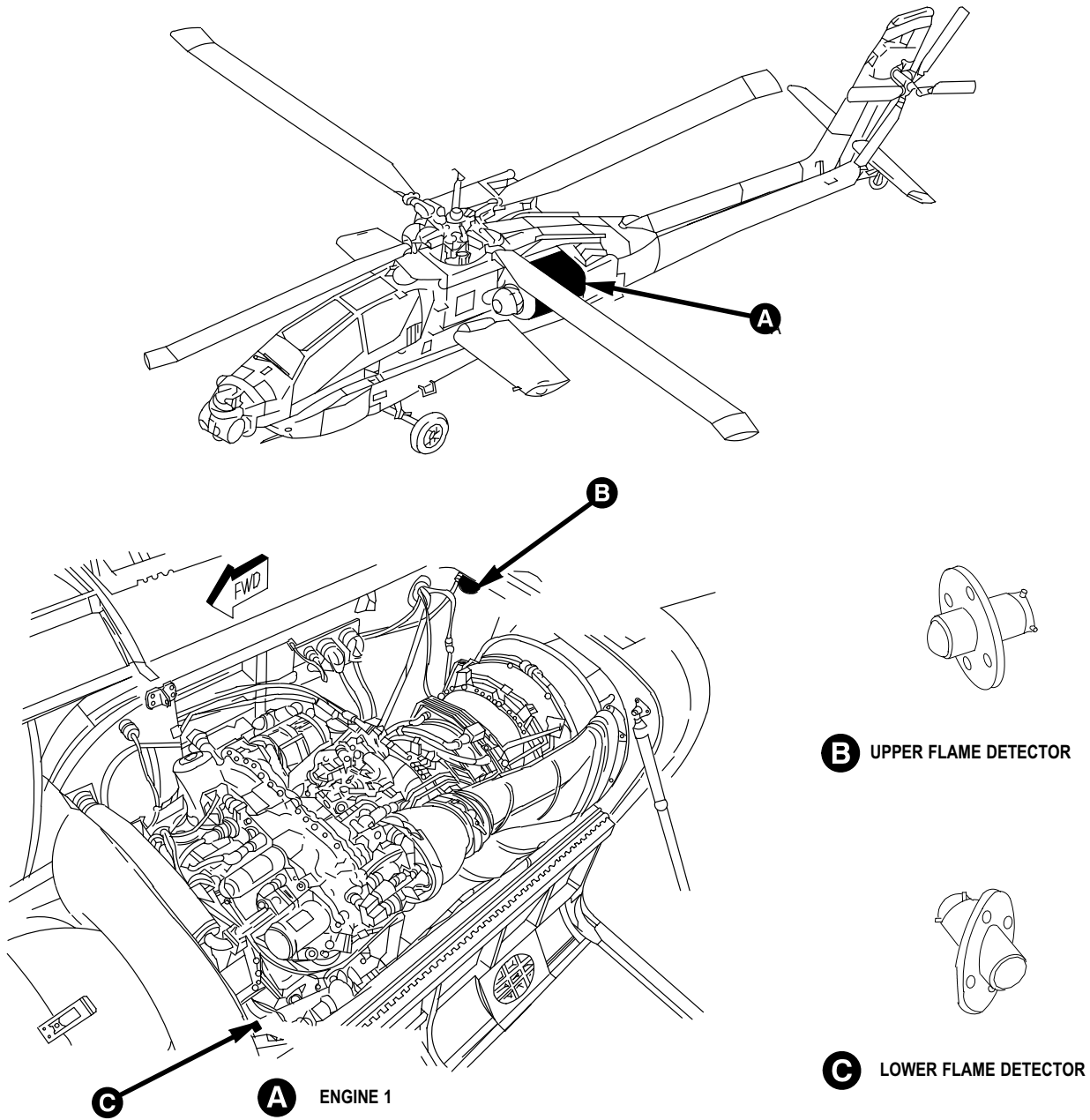

M71-085

Figure 12-88. Upper and Lower Flame Detectors Location



**12-99. ENGINE 1 FIRE DETECTION - MAINTENANCE OPERATIONAL CHECK (cont)**

**12-99**

Task	Result
j. Shine flashlight with no filter on engine 1 upper flame detector lens (fig. 12-88).	If pilot and CPG <b>ENG 1 FIRE PULL</b> handles (figs. 12-83 and 12-85) light, replace upper flame detector (TM 55-1520-238-23).
k. Remove rag from engine 1 lower flame detector and cover engine 1 upper flame detector lens with rag.	
l. Shine flashlight with a red filter on engine 1 lower flame detector lens.	If pilot and CPG <b>ENG 1 FIRE PULL</b> handles do not light, go to paragraph 12-109.
m. Shine flashlight with no filter on engine 1 lower flame detector lens.	If pilot and CPG <b>ENG 1 FIRE PULL</b> handles light, replace lower flame detector (TM 55-1520-238-23).
n. Remove rag from engine 1 upper flame detector.	

2. Perform ENGINE 1 FIRE DETECTION - POWER DOWN (para 12-98).
3. Close (LN1) engine 1 nacelle door (TM 55-1520-238-23).
4. Disconnect maintenance headset (TM 1-1520-238-T-4).

END OF TASK

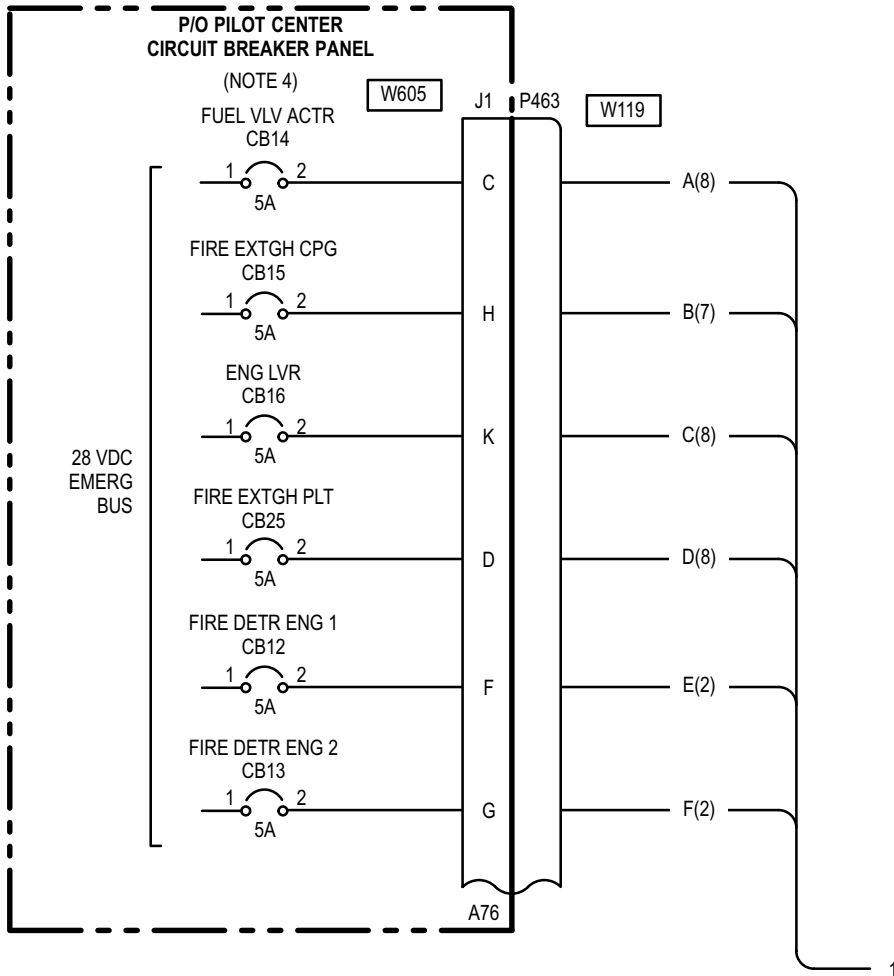

12-100. ENGINE FIRE DETECTION - WIRING INTERCONNECT DIAGRAM (cont)

12-100

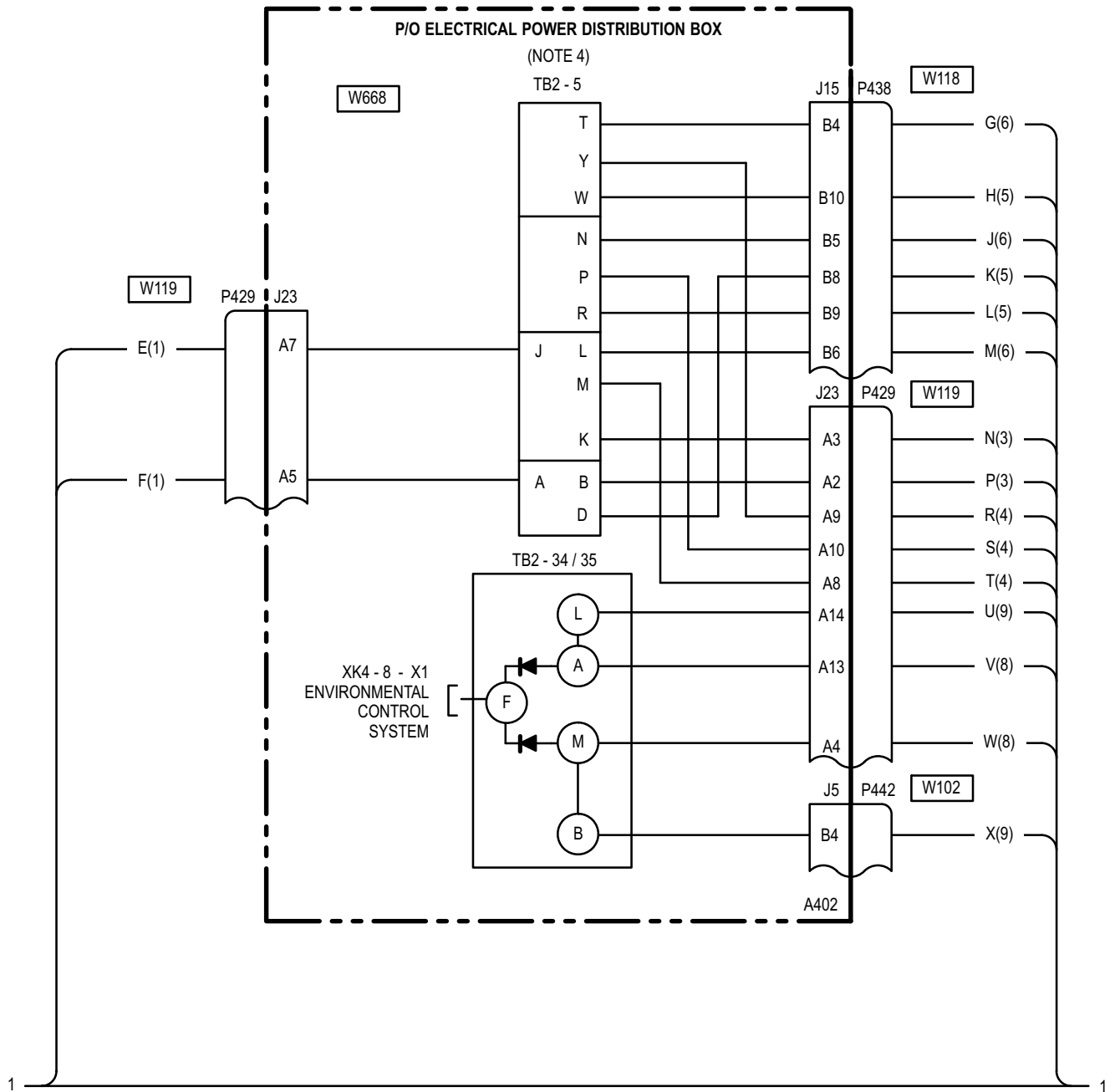

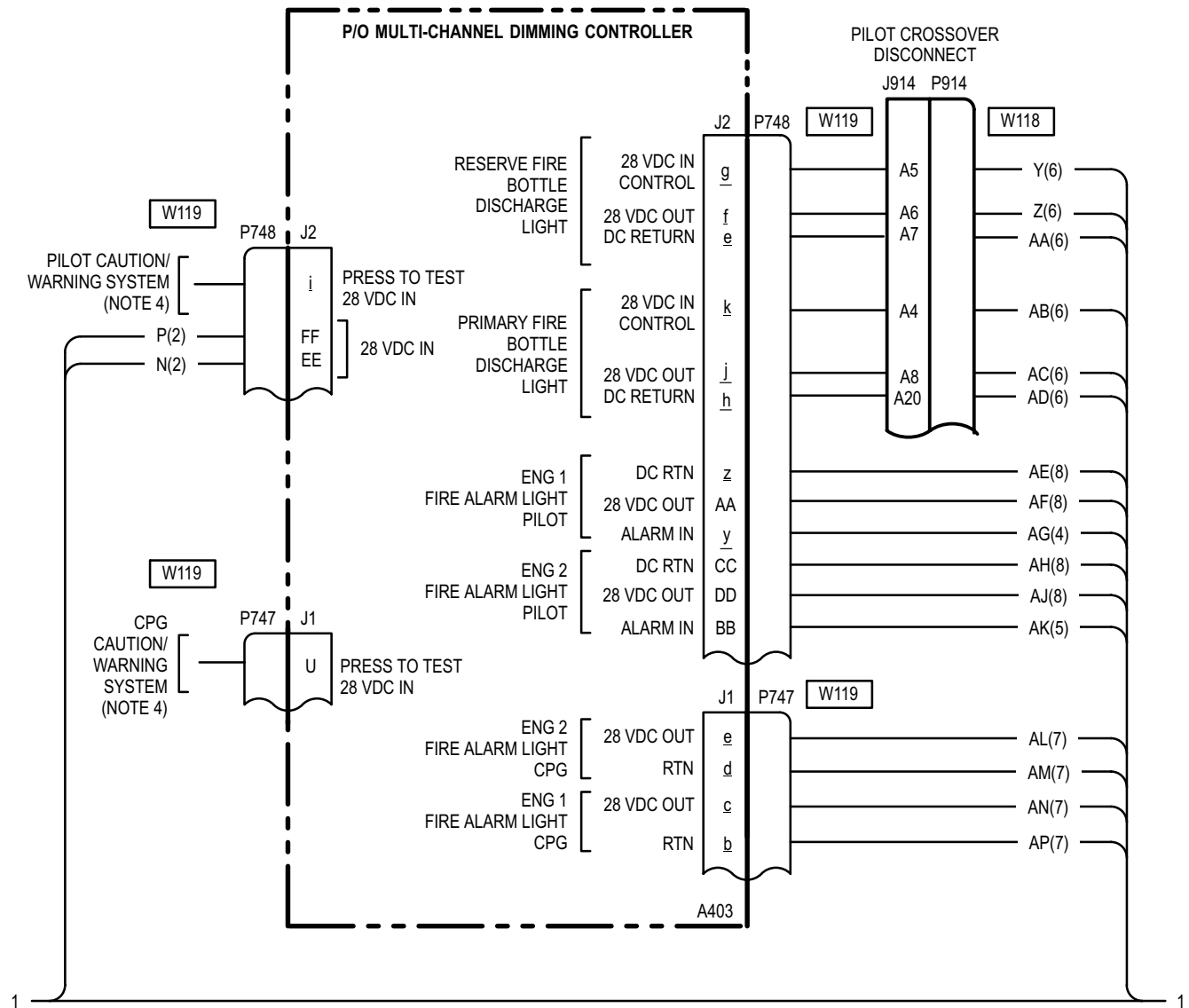

12-100. ENGINE FIRE DETECTION - WIRING INTERCONNECT DIAGRAM (cont)

12-100

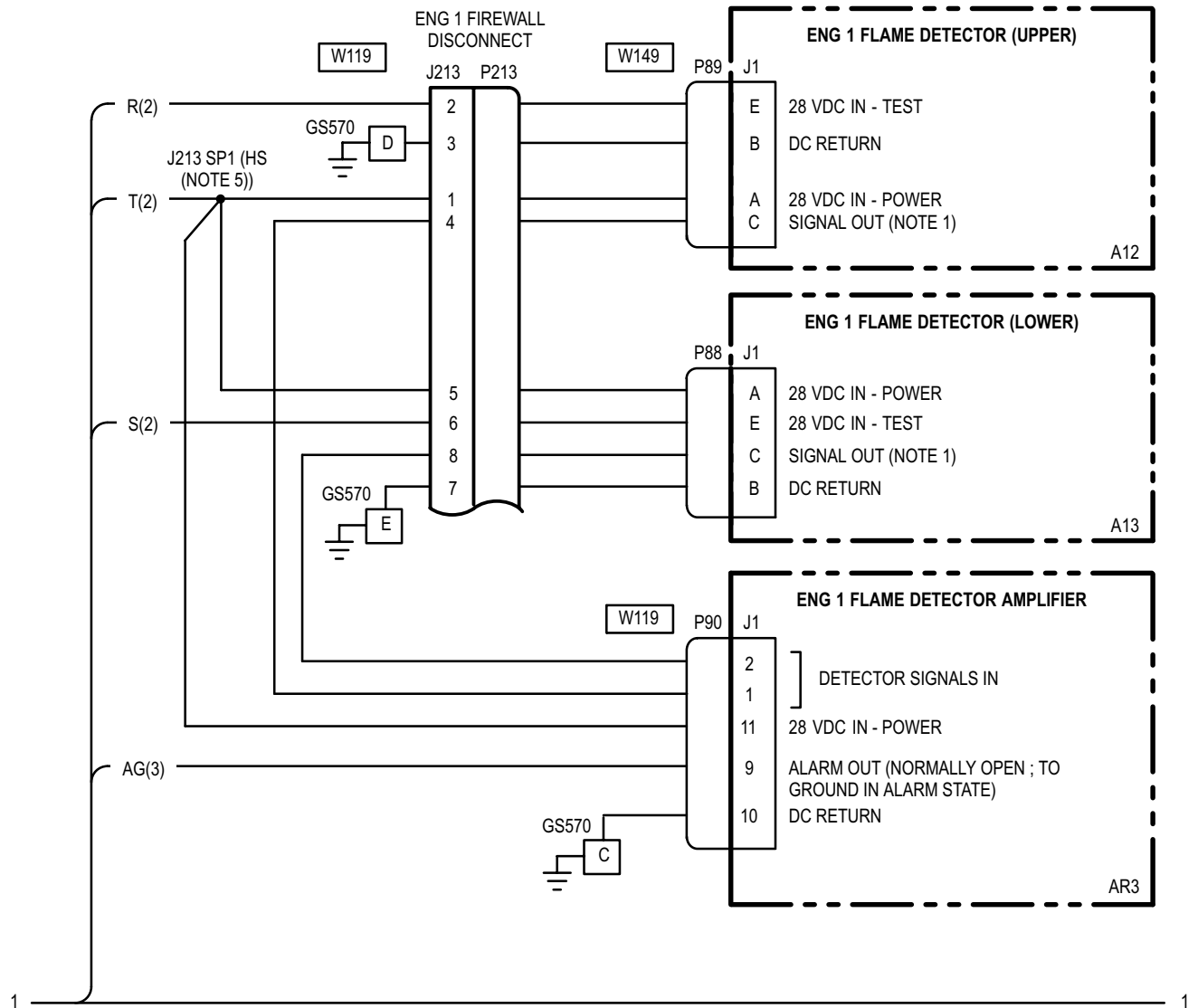

12-100. ENGINE FIRE DETECTION - WIRING INTERCONNECT DIAGRAM (cont)

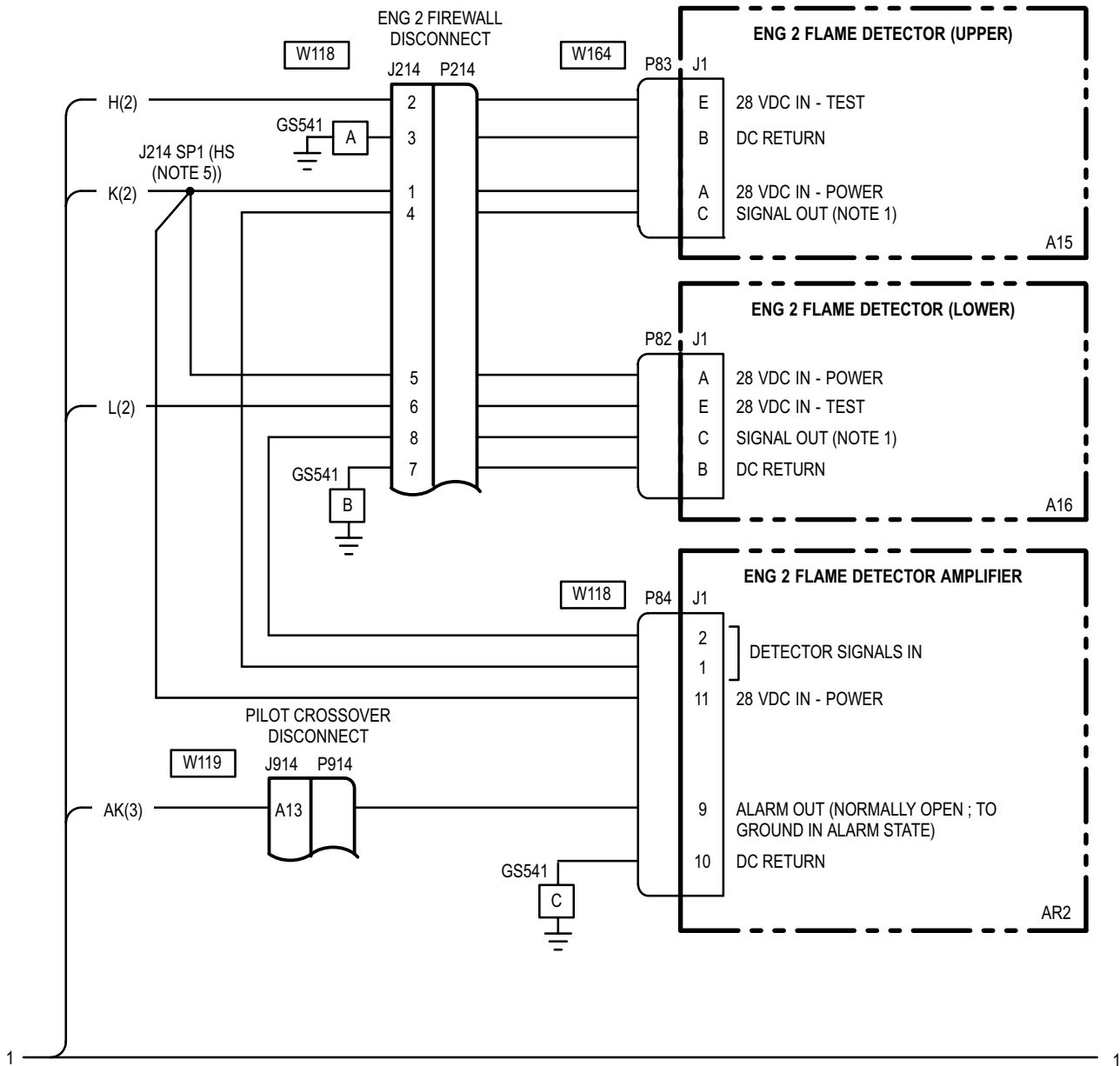

12-100. ENGINE FIRE DETECTION - WIRING INTERCONNECT DIAGRAM (cont)

12-100

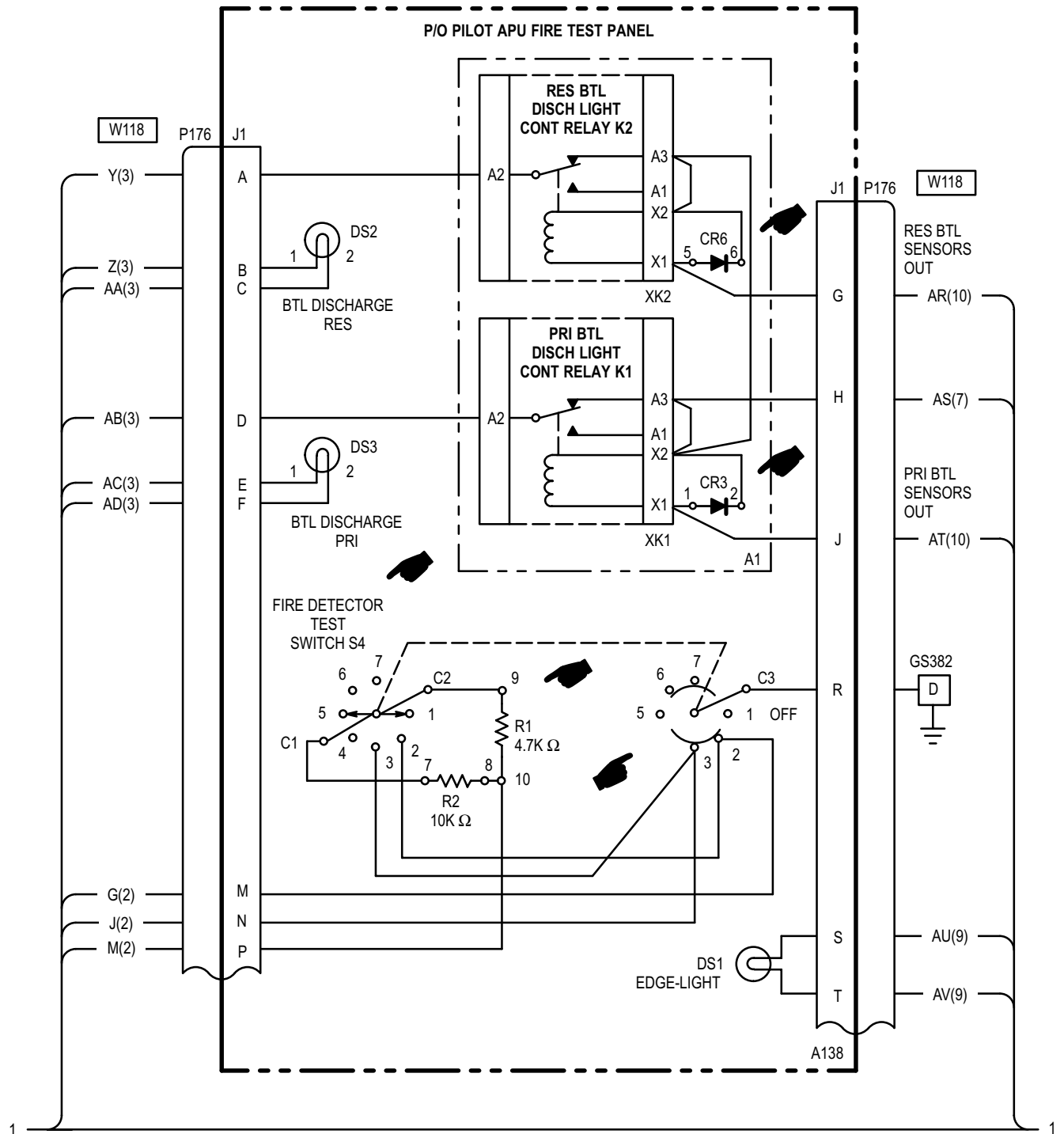

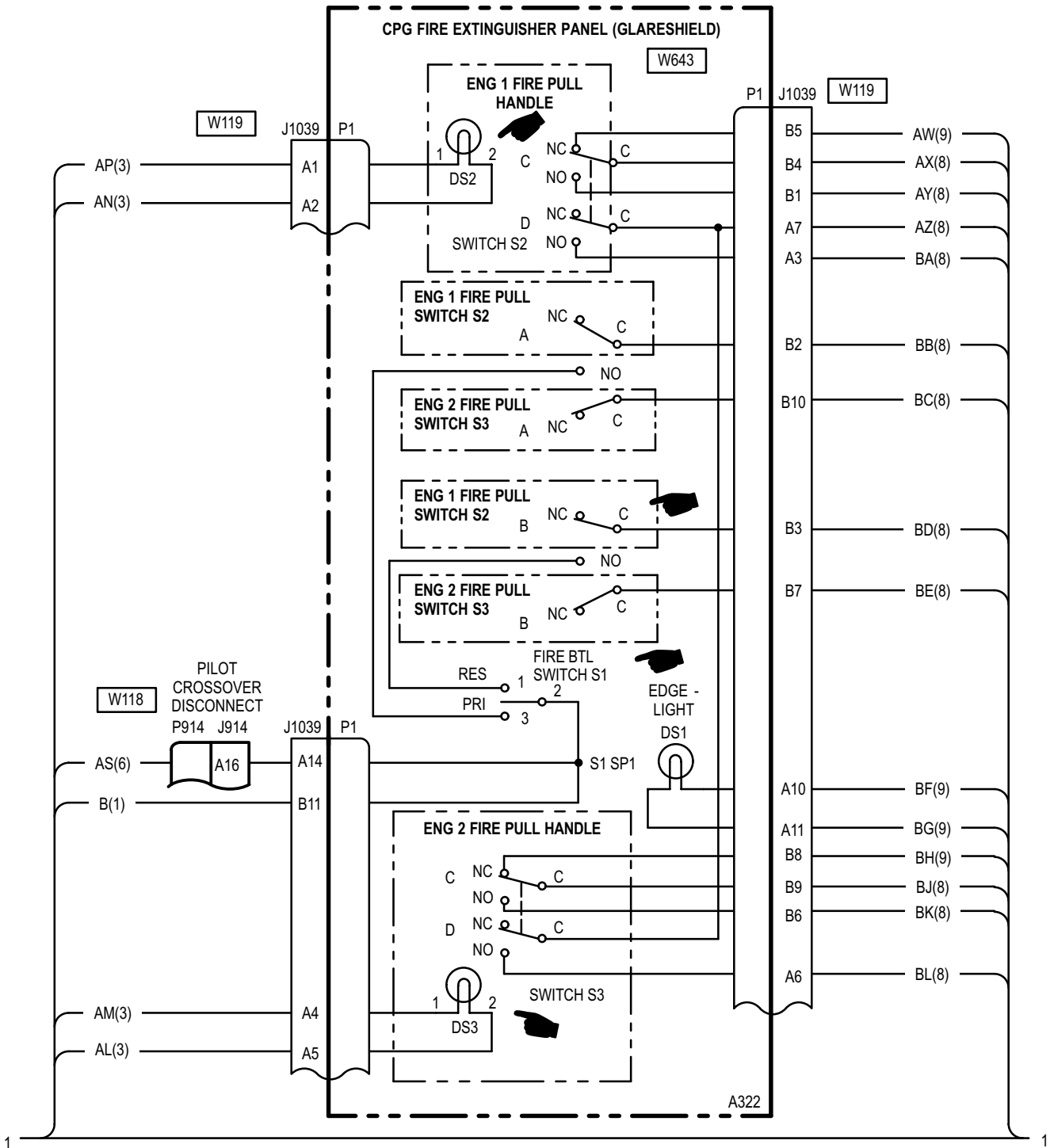



12-100. ENGINE FIRE DETECTION - WIRING INTERCONNECT DIAGRAM (cont)

12-100

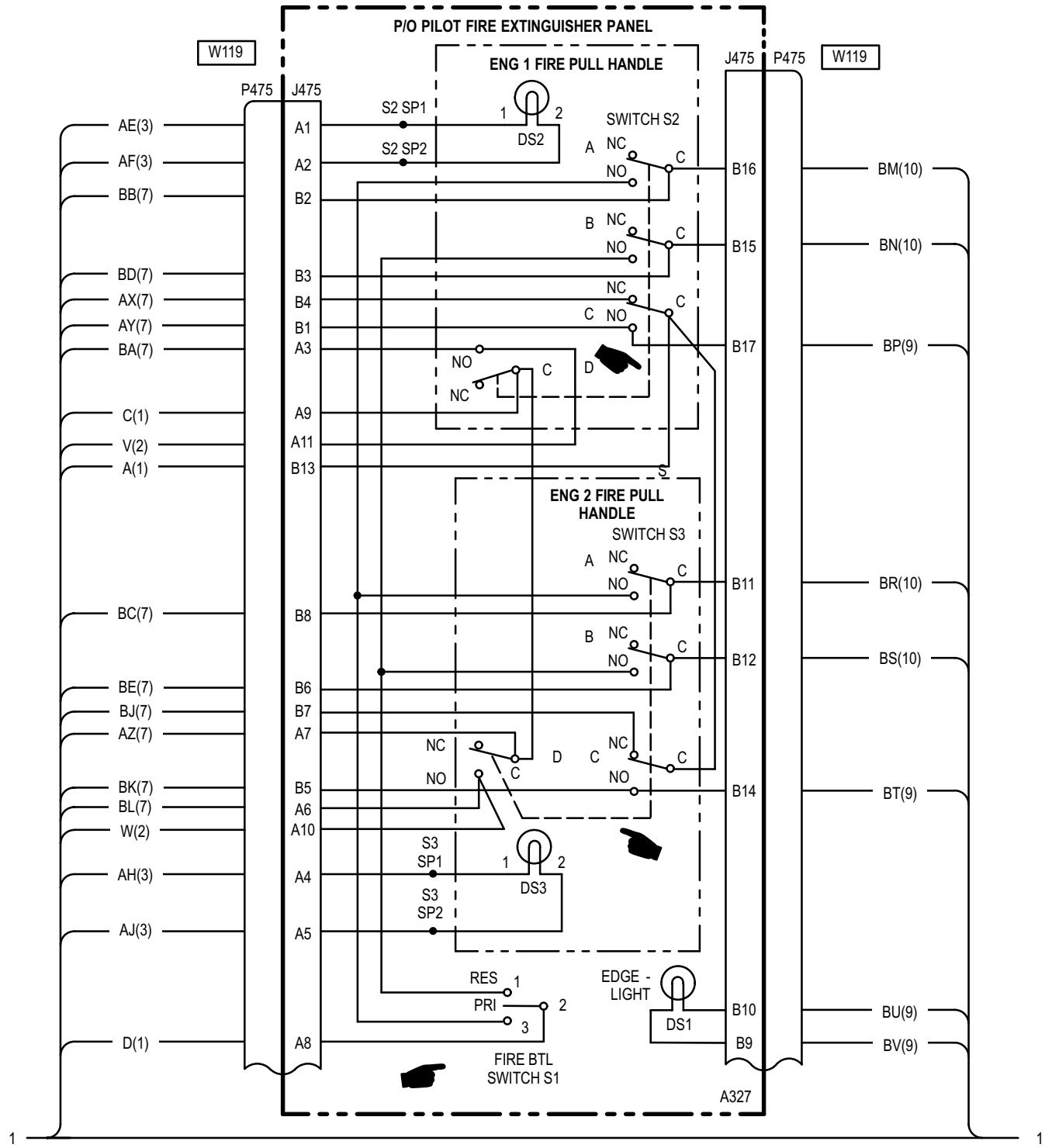

M71-219-8B  
SHEET 8 OF 10

12-100. ENGINE FIRE DETECTION - WIRING INTERCONNECT DIAGRAM (cont)

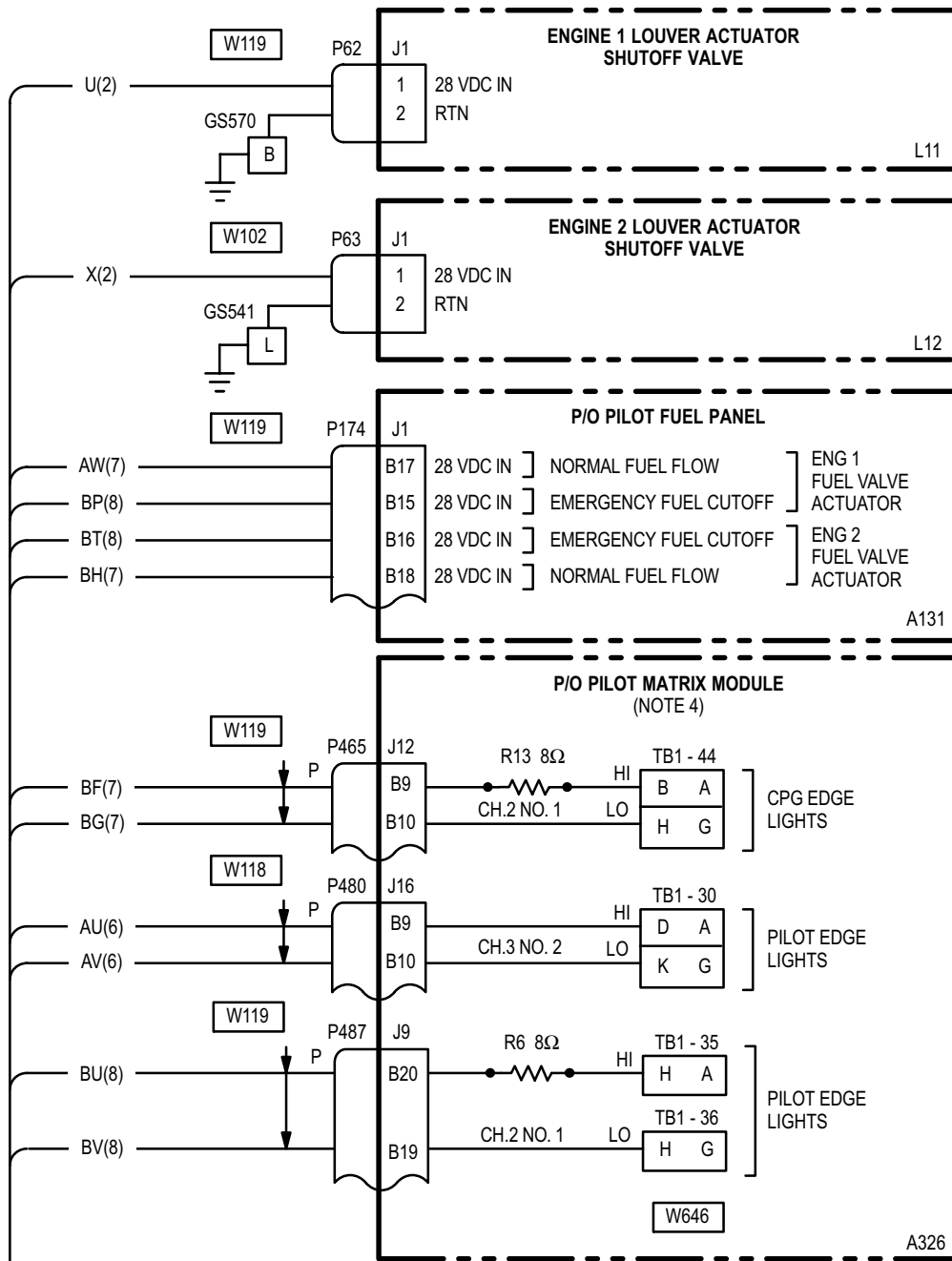

1

1

12-100. ENGINE FIRE DETECTION - WIRING INTERCONNECT DIAGRAM (cont)

12-100

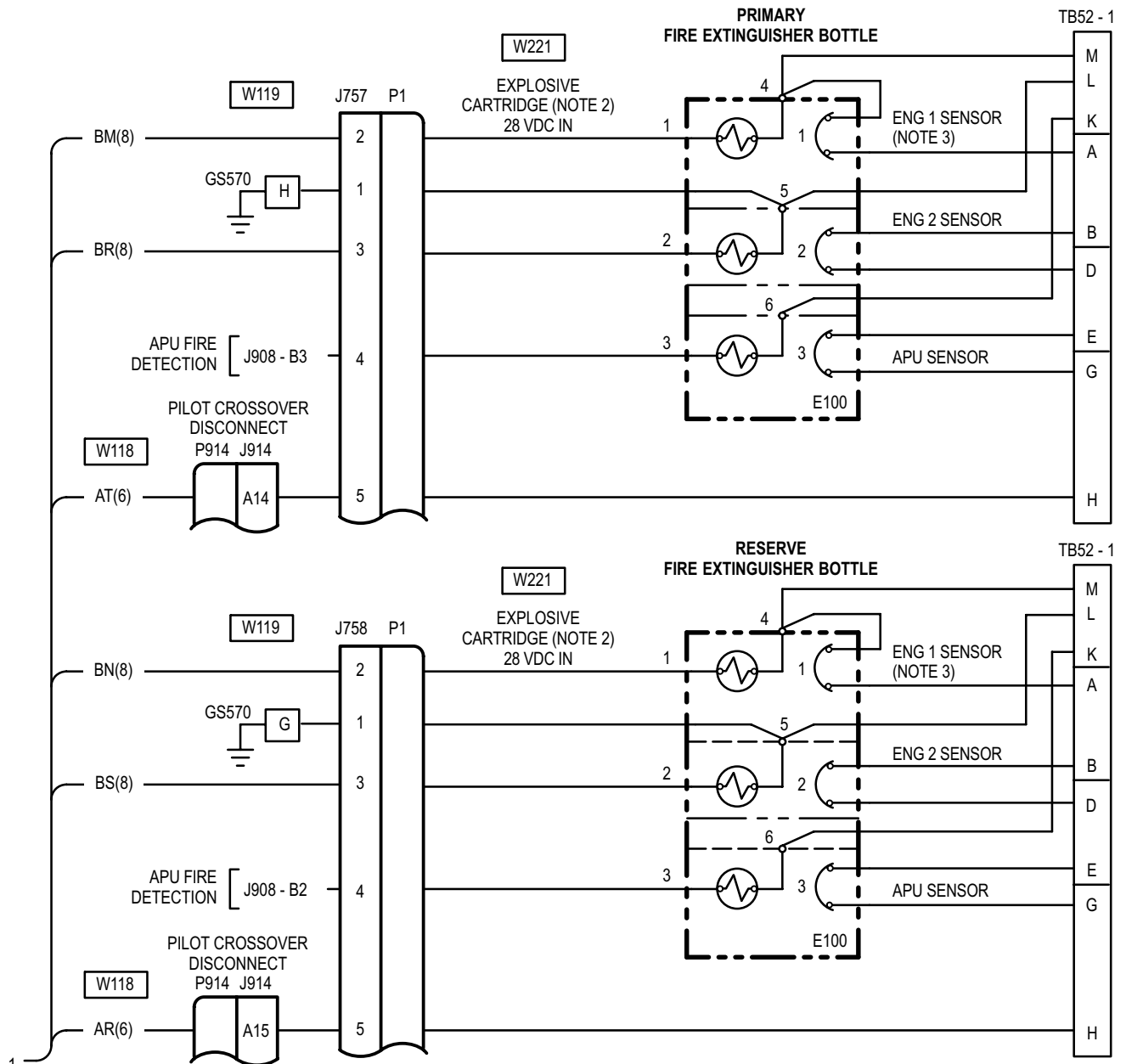

NOTES:

HIGHWAY USE: THE ALPHA CHARACTER IDENTIFIES A SPECIFIC LINE, AND THE NUMBER IN PARENTHESIS IDENTIFIES THE SHEET NUMBER WHERE THE SIGNAL TERMINATES.

1. FLAME DETECTOR FIRE OUTPUT VOLTAGE IS MINIMUM 12.5 VDC.
2. ELECTRICALLY ACTUATED.
3. OPEN AFTER BOTTLE DISCHARGES.
4. ELECTRICAL SYSTEM (TM 1-1520-238-T-6).
5. HS DESIGNATES A HARD SPLICE WHICH CANNOT BE DISCONNECTED.  
M DESIGNATES A SOFT SPLICE WHICH MAY BE DISCONNECTED FOR A WIRING CHECK.

M71-219-10A  
SHEET 10 OF 10

12-101. PILOT FIRE EXTINGUISHER PANEL EDGE-LIGHT - DOES NOT BRIGHTEN

12-101

**Tools:**

<u>Nomenclature</u>	<u>Part Number</u>
Tool Kit, Electrical Repairer's	SC518099CLA06
Multimeter, Digital	AN/PSM-45

**Personnel Required:**

68X Armament/Electrical Systems Repairer  
One person to assist

**References:**

TM 1-1520-238-T-6  
TM 55-1520-238-23

**Equipment Conditions:**

<u>Ref</u>	<u>Condition</u>
TM 55-1520-238-23	Non-transparent barrier removed

2. On pilot matrix module, check for 5 VDC between (A326):  
J9-B19 and J9-B20.

**Is voltage present?**

YES	Repair open wire between: P487-B19 and P475-B9, P487-B20 and P475-B10. Go to paragraph 12-99.
NO	Go to step 3.

3. Check for open between (A326):  
TB1-35-H and J9-B20,  
TB1-36-H and J9-B19.

**Does open exist?**

YES	Repair open wire. Go to paragraph 12-99.
NO	Refer to TM 1-1520-238-T-6 to troubleshoot pilot and CPG edge-lights.



**Turn off power before detaching or attaching wires and connectors. High current 28 VDC or 115 VAC is present. Failure to do so could result in death or serious injury.**

1. Rotate pilot **INST** control to **BRT**. Check for 5 VDC between P475-B9 and P475-B10.

**Is voltage present?**

YES	Replace pilot fire extinguisher panel edge-light (TM 55-1520-238-23).
NO	Go to step 2.

END OF TASK

**12-102. CPG FIRE EXTINGUISHER PANEL EDGE-LIGHT - DOES NOT BRIGHTEN****12-102****Tools:**

<u>Nomenclature</u>	<u>Part Number</u>
Tool Kit, Electrical Repairer's	SC518099CLA06
Multimeter, Digital	AN/PSM-45

**Personnel Required:**

68X Armament/Electrical Systems Repairer  
One person to assist

**References:**

TM 1-1520-238-T-6  
TM 55-1520-238-23

<b>WARNING</b>
----------------

**Turn off power before detaching or attaching wires and connectors. High current 28 VDC or 115 VAC is present. Failure to do so could result in death or serious injury.**

1. On CPG **INTR LT** panel, rotate **INST** control to **BRT**. Check for 5 VDC between J1039-A10 and J1039-A11.

**Is voltage present?**

YES	Replace CPG glareshield fire extinguisher panel edge-light (TM 55-1520-238-23).
NO	Go to step 2.

2. On pilot matrix module, check for 5 VDC between (A326):  
J12-B9 and J12-B10.

**Is voltage present?**

YES	Repair open wire between: P465-B9 and J1039-A10, P465-B10 and J1039-A11. Go to paragraph 12-99.
NO	Refer to TM 1-1520-238-T-6 to troubleshoot pilot and CPG edge-lights.

END OF TASK

**12-103. FIRE DETR ENG 1 CIRCUIT BREAKER (CB12) - DOES NOT STAY CLOSED**

**12-103**

**Tools:**

<u>Nomenclature</u>	<u>Part Number</u>
Tool Kit, Electrical Repairer's	SC518099CLA06
Multimeter, Digital	AN/PSM-45

**Personnel Required:**

68X Armament/Electrical Systems Repairer

**References:**

- TM 1-1520-238-T-6
- TM 55-1520-238-23

**WARNING**

**Turn off power before detaching or attaching wires and connectors. High current 28 VDC or 115 VAC is present. Failure to do so could result in death or serious injury.**

1. Check for short between P463-F and ground.  
**Does short exist?**
  - YES Go to step 2.
  - NO Refer to TM 1-1520-238-T-6 to troubleshoot circuit protection system (dc emergency bus - pilot station).
  
2. Detach P429. Check for short between P463-F and ground.  
**Does short exist?**
  - YES Repair short between P463-F and P429-A7.  
Go to paragraph 12-99.
  - NO Go to step 3.
  
3. Check for short between P436-B6 and ground.  
**Does short exist?**
  - YES Go to step 4.
  - NO Go to step 5.

4. Detach P176. Check for short between P438-B6 and ground.  
**Does short exist?**
  - YES Repair shorted wire between P438-B6 and P176-P.  
Go to paragraph 12-99.
  - NO Replace pilot **APU** fire test panel (TM 55-1520-238-23).
  
5. Check for short between P429-A8 and ground.  
**Does short exist?**
  - YES Go to step 8.
  - NO Go to step 6.
  
6. Detach P429 and P438. Check for short between (A402)J23-A7 and ground.  
**Does short exist?**
  - YES Repair shorted wire between (A402):  
J23-A7 and TB2-5-J,  
J23-A3 and TB2-5-K,  
J15-B6 and TB2-5-L,  
J23-A8 and TB2-5-M.  
Go to paragraph 12-99.
  - NO Go to step 7.
  
7. Detach P748. Check for short between P429-A3 and ground.  
**Does short exist?**
  - YES Repair shorted wire between P429-A3 and P748-EE.  
Go to paragraph 12-99.
  - NO Replace multi-channel dimming controller (TM 55-1520-238-23).
  
8. Detach P90. Check for short between P429-A8 and ground.  
**Does short exist?**
  - YES Go to step 9.
  - NO Replace engine 1 flame detector amplifier (TM 55-1520-238-23).

---

**12-103. FIRE DETR ENG 1 CIRCUIT BREAKER (CB12) - DOES NOT STAY CLOSED (cont)**

---

**12-103**

9. Detach P89 and P90. Check for short between P429-A8 and ground.

**Does short exist?**

- YES        Go to step 10.
- NO         Replace engine 1 flame detector (upper) (TM 55-1520-238-23).

10. Detach P88, P89 and P90. Check for short between P429-A8 and ground.

**Does short exist?**

- YES        Repair shorted wire between:  
P429-A8 and J213-1,  
P429-A8 and J213-5,  
P429-A8 and P90-11,  
P213-1 and P89-A,  
P213-5 and P88-A.  
Go to paragraph 12-99.
- NO         Replace engine 1 flame detector (lower) (TM 55-1520-238-23).

END OF TASK

12-104. PILOT ENG 1 FIRE PULL HANDLE - DOES NOT LIGHT

12-104

**Tools:**

<u>Nomenclature</u>	<u>Part Number</u>
Tool Kit, Electrical Repairer's	SC518099CLA06
Multimeter, Digital	AN/PSM-45

**Personnel Required:**

68X Armament/Electrical Systems Repairer  
One person to assist

**References:**

TM 55-1520-238-23

**Equipment Conditions:**

<u>Ref</u>	<u>Condition</u>
TM 55-1520-238-23	Nontransparent barrier removed Access provisions - L90 door opened

2. Check for open between:  
P748-AA and P475-A2,  
P748-z and P475-A1.

**Does open exist?**

YES	Repair open wire. Go to paragraph 12-99.
NO	Replace multi-channel dimming controller (TM 55-1520-238-23).

**WARNING**

**Turn off power before detaching or attaching wires and connectors. High current 28 VDC or 115 VAC is present. Failure to do so could result in death or serious injury.**

1. On pilot master caution/warning panel, press and hold **PRESS TO TEST** switch and check for 28 VDC between P475-A2 and P475-A1.

**Is voltage present?**

YES	Replace pilot <b>ENG 1 FIRE PULL</b> handle switch (TM 55-1520-238-23).
NO	Go to step 2.

END OF TASK



**12-105. CPG ENG 1 FIRE PULL HANDLE - DOES NOT LIGHT**

**12-105**

**Tools:**

<u>Nomenclature</u>	<u>Part Number</u>
Tool Kit, Electrical Repairer's	SC518099CLA06
Multimeter, Digital	AN/PSM-45

**Personnel Required:**

68X Armament/Electrical Systems Repairer  
One person to assist

**References:**

TM 1-1520-238-T-4  
TM 55-1520-238-23

**Equipment Conditions:**

<u>Ref</u>	<u>Condition</u>
TM 55-1520-238-23	Access provisions - L90 door opened



**Turn off power before detaching or attaching wires and connectors. High current 28 VDC or 115 VAC is present. Failure to do so could result in death or serious injury.**

1. Check for open between:  
P747-c and J1039-A2,  
P747-b and J1039-A1.

**Does open exist?**

- |     |   |
|-----|---|
| YES | Repair open wire.<br>Go to paragraph 12-99. |
| NO  | Go to step 2.                               |

2. On pilot master caution/warning panel, press **PRESS TO TEST** switch, check for 28 VDC at J1039-A2.

**Is voltage present?**

- |     |   |
|-----|---|
| YES | Replace CPG <b>ENG 1 FIRE PULL</b> handle switch (TM 55-1520-238-23). |
| NO  | Replace multi-channel dimming controller (TM 55-1520-238-23).         |

END OF TASK

**12-106. PILOT AND CPG ENG 1 FIRE PULL HANDLES - DO NOT LIGHT WITH FIRE TEST SWITCH IN DET 1 POSITION**

**Tools:**

<u>Nomenclature</u>	<u>Part Number</u>
Tool Kit, Electrical Repairer's	SC518099CLA06
Multimeter, Digital	AN/PSM-45

**Personnel Required:**

68X Armament/Electrical Systems Repairer  
One person to assist

**References:**

TM 1-1520-238-T-4  
TM 1-1520-238-T-6  
TM 55-1520-238-23

**Equipment Conditions:**

<u>Ref</u>	<u>Condition</u>
TM 55-1520-238-23	Access provisions - LN1 door opened

**WARNING**

**Turn off power before detaching or attaching wires and connectors. High current 28 VDC or 115 VAC is present. Failure to do so could result in death or serious injury.**

1. Check for 28 VDC at P90-11.  
**Is voltage present?**
  - YES Go to step 4.
  - NO Go to step 2.
  
2. On pilot circuit breaker panel, check for 28 VDC at (A76)J1-F.  
**Is voltage present?**
  - YES Go to step 3.
  - NO Refer to TM 1-1520-238-T-6 to troubleshoot circuit protection system (dc emergency bus - pilot station).

3. Check for 28 VDC at 176-P.  
**Is voltage present?**
  - YES Repair open wire between (A402)TB2-5-M and P90-11. Go to paragraph 12-99.
  - NO Repair open wire between P463-F and P176-P. Go to paragraph 12-99.
  
4. With **FIRE TEST** switch held at **DET 1** position, check for 28 VDC at P89-E.  
**Is voltage present?**
  - YES Go to step 5.
  - NO Go to step 6.
  
5. Check for open between P89-B and ground.  
**Does open exist?**
  - YES Repair open wire. Go to paragraph 12-99.
  - NO Go to step 7.
  
6. With **FIRE TEST** switch held at **DET 1** position, check for 4.7K ± 470 ohms between (A138): J1-P and J1-M.  
**Is proper resistance present?**
  - YES Repair open wire between P89-E and P176-M. Go to paragraph 12-99.
  - NO Replace **FIRE TEST** switch (TM 55-1520-238-23).

---

**12-106. PILOT AND CPG ENG 1 FIRE PULL HANDLES - DO NOT LIGHT WITH  
FIRE TEST SWITCH IN DET 1 POSITION (cont)**

---

12-106

7. With **FIRE TEST** switch held at **DET 1** position, check for 12.5 VDC minimum at P90-1.

**Is voltage present?**

YES        Go to step 8.

NO         Go to step 7.

8. Check for open between P89-C and P90-1.

**Does open exist?**

YES        Repair open wire.  
              Go to paragraph 12-99.

NO         Replace engine 1 upper flame  
              detector (TM 55-1520-238-23).

9. With **FIRE TEST** switch held at **DET 1** position, check for open between P748-y and ground.

**Does open exist?**

YES        Go to step 10.

NO         Replace multi-channel dimming  
              controller (TM 55-1520-238-23).

10. Check for open between P90-9 and P748-y.

**Does open exist?**

YES        Repair open wire.  
              Go to paragraph 12-99.

NO         Go to step 11.

11. Check for open between P90-10 and GS570-C.

**Does open exist?**

YES        Repair open wire.  
              Go to paragraph 12-99.

NO         Replace engine 1 flame detector  
              amplifier (TM 55-1520-238-23).

END OF TASK

**12-107. PILOT AND CPG ENG 1 FIRE PULL HANDLES - DO NOT LIGHT WITH FIRE TEST SWITCH IN DET 2 POSITION**

**Tools:**

<u>Nomenclature</u>	<u>Part Number</u>
Tool Kit, Electrical Repairer's	SC518099CLA06
Multimeter, Digital	AN/PSM-45

**Personnel Required:**

68X Armament/Electrical Systems Repairer  
One person to assist

**References:**

TM 1-1520-238-T-6  
TM 55-1520-238-23

**Equipment Conditions:**

<u>Ref</u>	<u>Condition</u>
TM 55-1520-238-23	Access provisions - LN1 engine 1 (left) nacelle door opened

**WARNING**

**Turn off power before detaching or attaching wires and connectors. High current 28 VDC or 115 VAC is present. Failure to do so could result in death or serious injury.**

1. With **FIRE TEST** switch held at **DET 2** position, check for 28 VDC at P88-E.

**Is voltage present?**

- YES      Go to step 2.
- NO        Go to step 3.

2. Check for open between P88-B and ground.

**Does open exist?**

- YES      Repair open wire.  
            Go to paragraph 12-99.
- NO        Go to step 4.

3. With **FIRE TEST** switch held at **DET 2** position, check for  $4.7K \pm 470$  ohms between (A138): J1-P and J1-N.

**Is proper resistance present?**

- YES      Repair open wire between P88-E and P176-N.  
            Go to paragraph 12-99.
- NO        Replace **FIRE TEST** switch (TM 55-1520-238-23).

4. With **FIRE TEST** switch held at **DET 2** position, check for 12.5 VDC minimum at P90-2 and ground.

**Is voltage present?**

- YES      Replace engine flame detector amplifier (TM 55-1520-238-23).
- NO        Go to step 5.

5. Check for open between P88-C and P90-2.

**Does open exist?**

- YES      Repair open wire.  
            Go to paragraph 12-99.
- NO        Replace engine 1 lower flame detector (TM 55-1520-238-23).

END OF TASK

**12-108. PILOT AND CPG ENG 1 FIRE PULL HANDLES - DO NOT LIGHT  
(UPPER FLAME DETECTOR LENS)**

**12-108**

**Tools:**

<u>Nomenclature</u>	<u>Part Number</u>
Tool Kit, Electrical Repairer's	SC518099CLA06
Multimeter, Digital	AN/PSM-45

**Personnel Required:**

68X Armament/Electrical Systems Repairer  
One person to assist

**References:**

TM 55-1520-238-23

**Equipment Conditions:**

<u>Ref</u>	<u>Condition</u>
TM 55-1520-238-23	Access provisions - LN1 engine 1 (left) nacelle door opened

<b>WARNING</b>
----------------

**Turn off power before detaching or attaching wires and connectors. High current 28 VDC or 115 VAC is present. Failure to do so could result in death or serious injury.**

1. Check for 28 VDC at P89-A.

**Is voltage present?**

YES	Go to step 2.
NO	Repair open wire between P89-A and J213 SP1. Go to paragraph 12-99.

2. Shine a red-filtered light source on engine 1 upper flame detector lens. Check for a minimum of 12.5 VDC at P90-1.

**Is proper voltage present?**

YES	Replace engine 1 flame detector amplifier (TM 55-1520-238-23).
NO	Replace engine 1 upper flame detector (TM 55-1520-238-23).

END OF TASK

**12-109. PILOT AND CPG ENG 1 FIRE PULL HANDLES - DO NOT LIGHT  
(LOWER FLAME DETECTOR LENS)**

**12-109**

**Tools:**

<u>Nomenclature</u>	<u>Part Number</u>
Tool Kit, Electrical Repairer's	SC518099CLA06
Multimeter, Digital	AN/PSM-45

- Shine a red-filtered light source on engine 1 upper flame detector lens. Check for a minimum of 12.5 VDC at P90-2.  
**Is proper voltage present?**

**Personnel Required:**

68X Armament/Electrical Systems Repairer  
One person to assist

YES Replace engine 1 flame detector amplifier (TM 55-1520-238-23).

NO Replace engine 1 lower flame detector (TM 55-1520-238-23).

**References:**

TM 55-1520-238-23

**Equipment Conditions:**

<u>Ref</u>	<u>Condition</u>
TM 55-1520-238-23	Access provisions - LN1 engine 1 (left) nacelle door opened

**WARNING**

**Turn off power before detaching or attaching wires and connectors. High current 28 VDC or 115 VAC is present. Failure to do so could result in death or serious injury.**

- Check for 28 VDC at P88-A.

**Is voltage present?**

- |     |  |
|-----|--|
| YES | Go to step 2.  |
| NO  | Repair open wire between P88-A and J213 SP1.<br>Go to paragraph 12-99. |

END OF TASK

12-1 10. ENGINE 2 FIRE DETECTION - POWER UP

12-1 10

**Tools:**

Nomenclature	Part Number
Tool Kit, Electrical Repairer's	SC518099CLA06

**Personnel Required:**

68X Armament/Electrical Systems Repairer

**References:**

TM 55-1520-238-23

**Equipment Conditions:**

Ref	Condition
TM 55-1520-238-23	Helicopter safed External power application - Electrical Engine 2 fire detection system inspection completed

**NOTE**

Refer to pilot station (fig. 12-89) and CPG station (fig. 12-89) for cockpit configuration and equipment.

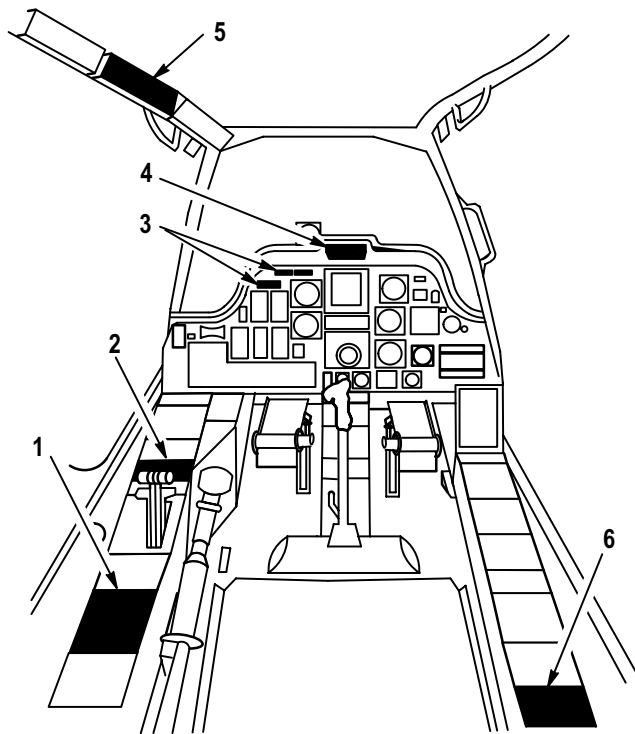

1. PILOT EXT LT/INTR LT PANEL
2. PILOT ELEC PWR PANEL
3. PILOT FIRE EXTINGUISHER PANEL
4. PILOT MASTER CAUTION/WARNING PANEL
5. PILOT CENTER CIRCUIT BREAKER PANEL
6. PILOT APU FIRE TEST PANEL

M71-098A

Figure 12-89. Pilot Station

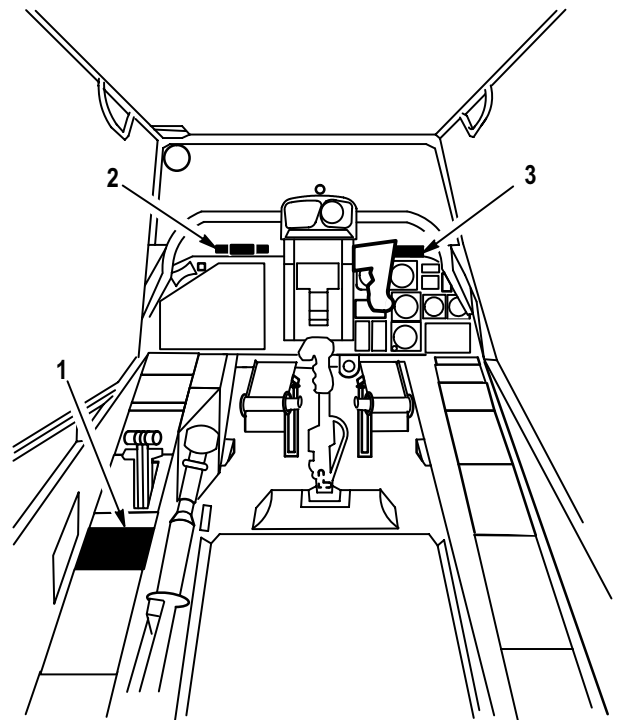

1. CPG INTR LT PANEL
2. CPG GLARESHIELD FIRE EXTINGUISHER PANEL
3. CPG MASTER CAUTION/WARNING PANEL

M71-099

Figure 12-89. CPG Station

1. On pilot center circuit breaker panel (fig. 12-91), check that the following circuit breakers are closed:

Circuit Breaker

**FIRE DETR ENG 1**

**FIRE DETR ENG 2**

**LT PRI**

**LT CAUT**

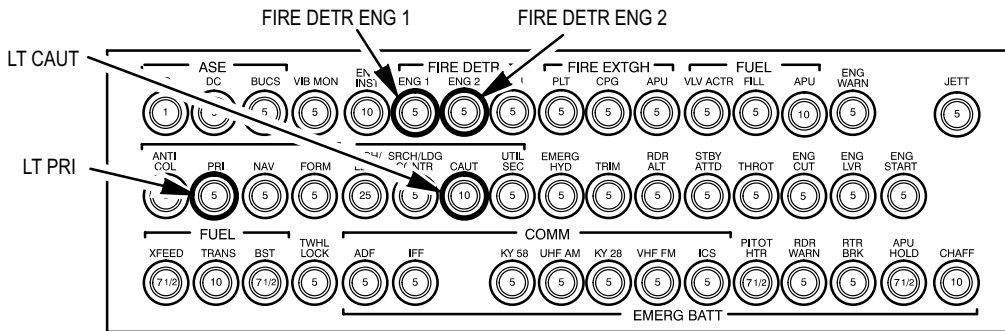

M71-100

**Figure 12-91. Pilot Center Circuit Breaker Panel**

2. On pilot **ELEC PWR** panel (fig. 12-92), set **BATT/EXT PWR** switch to **EXT PWR**.

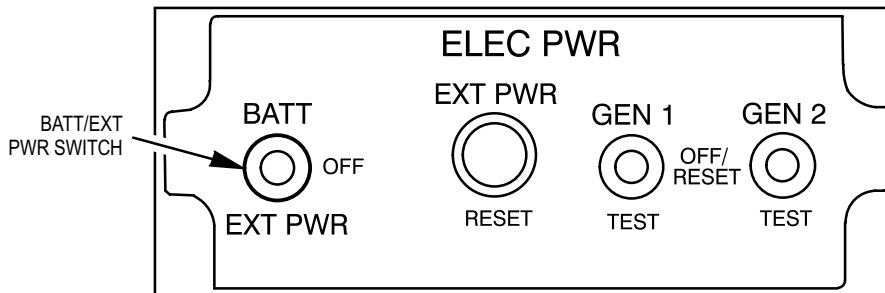

M71-101

**Figure 12-92. Pilot ELEC PWR Panel**

END OF TASK



---

**12-1 11. ENGINE 2 FIRE DETECTION - POWER DOWN**

---

12-1 11

**Tools:**

<u>Nomenclature</u>	<u>Part Number</u>
Tool Kit, Electrical Repairer's	SC518099CLA06

**References:**

TM 55-1520-238-23

**Equipment Conditions:**

<u>Ref</u>	<u>Condition</u>
Paragraph 12-110	ENGINE 2 FIRE DETECTION - POWER UP completed

**Personnel Required:**68X Armament/Electrical Systems Repairer

---

**NOTE**

**Refer to pilot station (fig. 12-89) and CPG station (fig. 12-89) for cockpit configuration and equipment.**

1. On pilot center circuit breaker panel (fig. 12-91), open the following circuit breakers:

Circuit Breaker

**FIRE DETR ENG 2**

**FIRE DETR ENG 1**

**LT CAUT**

**LT PRI**

2. On pilot **ELEC PWR** panel (fig. 12-92), set **BATT/EXT PWR** switch to **OFF**.
3. Remove external power - electrical (TM 55-1520-238-23).

END OF TASK

12-1 12. ENGINE 2 FIRE DETECTION - MAINTENANCE OPERATIONAL CHECK

12-1 12

**Tools:**

<u>Nomenclature</u>	<u>Part Number</u>
Tool Kit, Electrical Repairer's	SC518099CLA06
Multimeter, Digital	AN/PSM-45

**Equipment Conditions:**

<u>Ref</u>	<u>Condition</u>
TM 55-1520-238-23	Access provisions - (RNI) engine 2 (right) nacelle door open
Paragraph 12-110	ENGINE 2 FIRE DETECTION - POWER UP completed
TM 1-1520-238-T-4	Maintenance headset connected

**Personnel Required:**

68X Armament/Electrical Systems Repairer  
One person to assist

**References:**

TM 1-1520-238-T-4  
TM 55-1520-238-23

**NOTE**

- Refer to pilot station (fig. 12-89) and CPG station (fig. 12-89) for cockpit configuration and equipment.
- If referenced out of one paragraph or volume into another for additional troubleshooting, upon completion of the task, return to the maintenance operational check for the original paragraph or volume.

1. Perform the maintenance operational check as follows:

<u>Task</u>	<u>Result</u>
a. On pilot center circuit breaker panel (fig. 12-91), check that <b>FIRE DETR ENG 1</b> circuit breaker is closed.	If <b>FIRE DETR ENG 1</b> circuit breaker does not stay closed, go to paragraph 12-103.
b. On pilot center circuit breaker panel, check that <b>FIRE DETR ENG 2</b> circuit breaker is closed.	If <b>FIRE DETR ENG 2</b> circuit breaker does not stay closed, go to paragraph 12-114.
c. On pilot master caution/warning panel (fig. 12-93), press and hold the <b>PRESS TO TEST</b> switch.	If <b>ENG 2 FIRE PULL</b> handle on pilot fire extinguisher panel (fig. 12-94) does not light, replace lamp (TM 55-1520-238-23). If lamp still does not light, go to paragraph 12-115.
d. On CPG master caution/warning panel, press and hold the <b>PRESS TO TEST</b> switch.	If <b>ENG 2 FIRE PULL</b> handle on CPG fire extinguisher panel (fig. 12-95) does not light, replace lamp (TM 55-1520-238-23). If lamp still does not light, go to paragraph 12-116.

12-1 12. ENGINE 2 FIRE DETECTION - MAINTENANCE OPERATIONAL CHECK (cont)

12-1 12

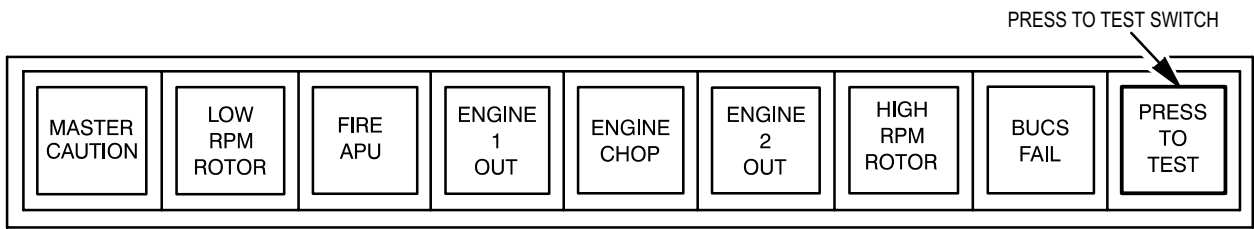

M71-103

Figure 12-93. Master Caution/Warning Panel

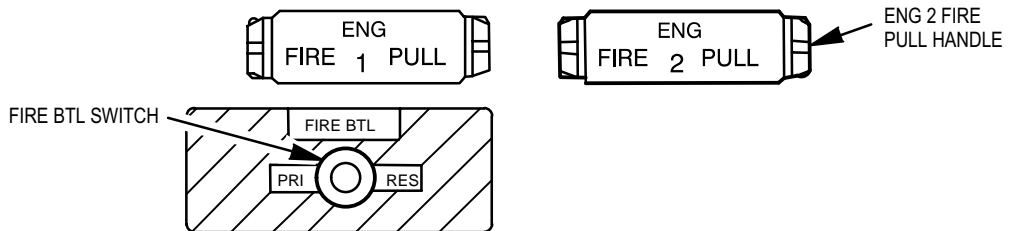

M71-104

Figure 12-94. Pilot Fire Extinguisher Panel

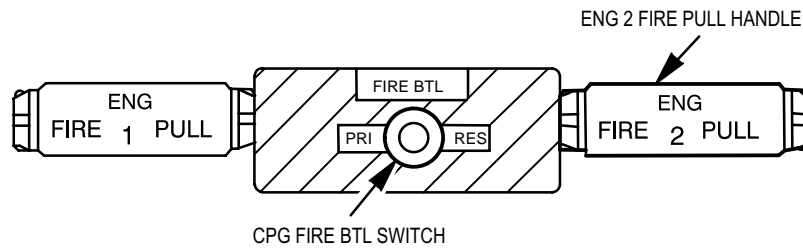

M71-105

Figure 12-95. CPG Fire Extinguisher Panel

- e. On pilot **APU** fire test panel (fig. 12-96), hold **FIRE TEST DET** switch at 1.

If pilot and CPG **ENG 2 FIRE PULL** handles (figs. 12-94 and 12-95) do not light, go to paragraph 12-117.

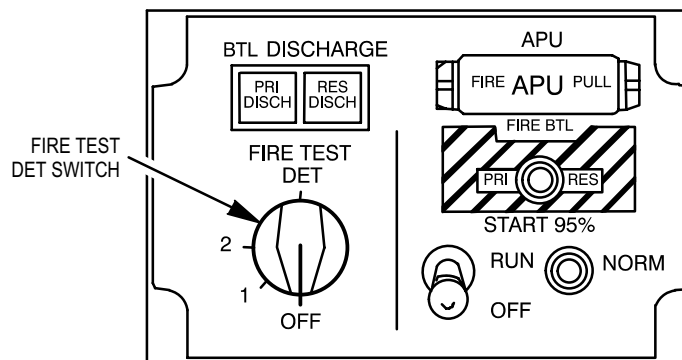

M71-106A

Figure 12-96. Pilot APU Fire Test Panel

12-1 12. ENGINE 2 FIRE DETECTION - MAINTENANCE OPERATIONAL CHECK (cont)

12-1 12

Task	Result
f. Hold <b>FIRE TEST DET</b> switch at <b>2</b> .	If pilot and CPG <b>ENG 2 FIRE PULL</b> handles do not light, go to paragraph 12-118.
g. Release <b>FIRE TEST DET</b> switch, allowing it to return to <b>OFF</b> .	

**NOTE**

Place helicopter in shade or indoors during maintenance operational check of flame detectors.

h. Cover engine 2 lower flame detector lens (fig. 12-97) with a rag.	
i. Shine flashlight with a red filter on engine 2 upper flame detector lens.	If pilot and CPG <b>ENG 2 FIRE PULL</b> handles do not light, go to paragraph 12-119.
j. Shine flashlight with no filter on engine 2 upper flame detector lens.	If pilot and CPG <b>ENG 2 FIRE PULL</b> handles light, replace upper flame detector (TM 55-1520-238-23).
k. Remove rag from engine 2 lower flame detector and cover engine 2 upper flame detector lens with rag.	
l. Shine flashlight with a red filter on engine 2 lower flame detector lens.	If pilot and CPG <b>ENG 2 FIRE PULL</b> handles do not light, go to paragraph 12-120.
m. Shine flashlight with no filter on engine 2 lower flame detector lens.	If pilot and CPG <b>ENG 2 FIRE PULL</b> handles light (figs. 12-94 fig. 12-95), replace lower flame detector (TM 55-1520-238-23).
n. Remove rag from engine 2 upper flame detector.	

2. Perform ENGINE 2 FIRE DETECTION - POWER DOWN (para 12-111).
3. Close (RN1) engine 2 nacelle door (TM 55-1520-238-23).
4. Disconnect maintenance headset (TM 1-1520-238-T-4).

END OF TASK

12-1 12. ENGINE 2 FIRE DETECTION - MAINTENANCE OPERATIONAL CHECK (cont)

12-1 12

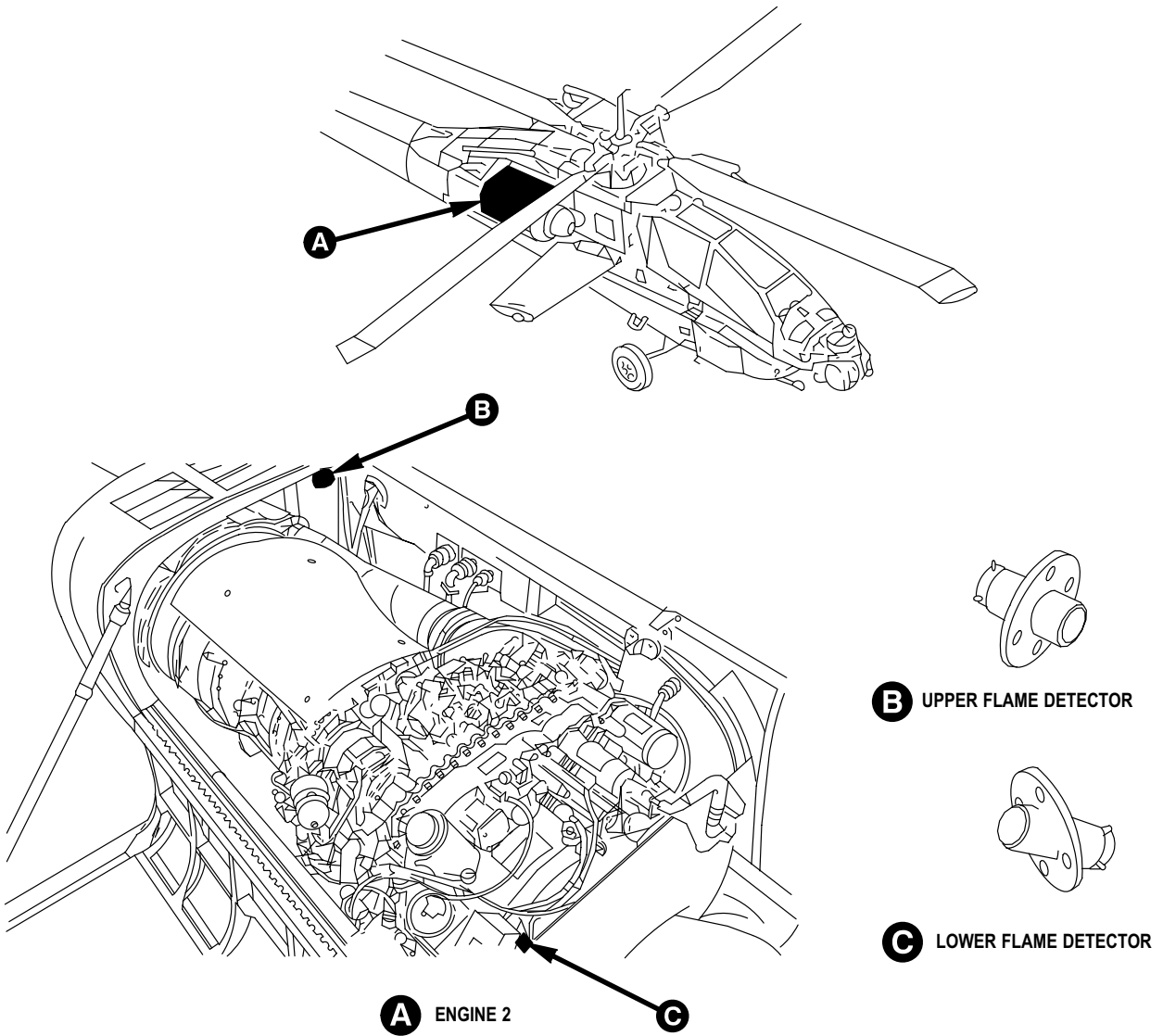

M71-102

Figure 12-97. Upper and Lower Flame Detectors

12-1 13. ENGINE 2 FIRE DETECTION - WIRING INTERCONNECT DIAGRAM

12-1 13

Engine 2 fire detection circuitry is included in ENGINE FIRE DETECTION - WIRING INTERCONNECT DIAGRAM (para 12-100).

12-1 14. FIRE DETR ENG 2 CIRCUIT BREAKER (CB13) - DOES NOT STAY CLOSED

12-1 14

**Tools:**

<u>Nomenclature</u>	<u>Part Number</u>
Tool Kit, Electrical Repairer's	SC518099CLA06
Multimeter, Digital	AN/PSM-45

**Personnel Required:**

68X Armament/Electrical Systems Repairer

**References:**

TM 1-1520-238-T-6  
 TM 55-1520-238-23

**Equipment Conditions:**

<u>Ref</u>	<u>Condition</u>
TM 55-1520-238-23	Access provisions - RN1 engine 2 (right) nacelle door opened



**Turn off power before detaching or attaching wires and connectors. High current 28 VDC or 115 VAC is present. Failure to do so could result in death or serious injury.**

1. Check for short between P463-G and ground.  
**Does short exist?**
  - YES Go to step 2.
  - NO Refer to TM 1-1520-238-T-6 to troubleshoot circuit protection system (dc emergency bus - pilot station).
  
2. Check for short between (A402)J23-A5 and ground.  
**Does short exist?**
  - YES Go to step 4.
  - NO Go to step 3.

3. Check for short between P429-A2 and ground.  
**Does short exist?**
  - YES Repair shorted wire between P429-A2 and P748-FF. Go to paragraph 12-112.
  - NO Repair shorted wire between P463-G and P429-A5. Go to paragraph 12-112.
  
4. Detach P438. Check for short between (A402)J23-A5 and ground.  
**Does short exist?**
  - YES Repair shorted wire between (A402): TB2-5-A and J23-A5, TB2-5-B and J23-A2, TB2-5-D and J15-B8. Go to paragraph 12-112.
  - NO Go to step 5.
  
5. Detach P84 and check for short between P438-B8 and ground.  
**Does short exist?**
  - YES Go to step 6.
  - NO Replace engine 2 flame detector amplifier (TM 55-1520-238-23).
  
6. Detach P83 and P84 and check for short between P438-B8 and ground.  
**Does short exist?**
  - YES Go to step 7.
  - NO Replace engine 2 flame detector (upper) (TM 55-1520-238-23).

---

**12-1 14. FIRE DETR ENG 2 CIRCUIT BREAKER (CB13) - DOES NOT STAY CLOSED (cont)**

---

12-1 14

7. Detach P82, P83 and P84. Check for short between P438-B8 and ground.

**Does short exist?**

- |     |   |
|-----|---|
| YES | Repair shorted wire between:<br>P438-B8 and J214-1,<br>P438-B8 and J214-15,<br>P438-B8 and P84-11,<br>P214-1 and P83-A,<br>P214-5 and P82-A.<br>Go to paragraph 12-112. |
| NO  | Replace engine 2 flame detector<br>(lower) (TM 55-1520-238-23).   |

END OF TASK

12-1 15. PILOT ENG 2 FIRE PULL HANDLE - DOES NOT LIGHT

12-1 15

**Tools:**

<u>Nomenclature</u>	<u>Part Number</u>
Tool Kit, Electrical Repairer's	SC518099CLA06
Multimeter, Digital	AN/PSM-45

**Personnel Required:**

68X Armament/Electrical Systems Repairer  
One person to assist

**References:**

TM 55-1520-238-23

**Equipment Conditions:**

<u>Ref</u>	<u>Condition</u>
TM 55-1520-238-23	Access provisions - L60 fairing removed

2. Check for open between: P748-DD and P475-A5, P748-CC and P475-A4.

**Does open exist?**

YES	Repair open wire. Go to paragraph 12-112.
NO	Replace multi-channel dimming controller (TM 55-1520-238-23).

**WARNING**

**Turn off power before detaching or attaching wires and connectors. High current 28 VDC or 115 VAC is present. Failure to do so could result in death or serious injury.**

1. Press and hold the pilot master caution/warning **PRESS TO TEST** switch, check for 28 VDC between P475-A5 and P475-A4.

**Is voltage present?**

YES	Replace pilot <b>ENG 2 FIRE PULL</b> handle switch (TM 55-1520-238-23).
NO	Go to step 2.

END OF TASK



---

**12-1 16. CPG ENG 2 FIRE PULL HANDLE - DOES NOT LIGHT**

---

12-1 16

**Tools:**

<u>Nomenclature</u>	<u>Part Number</u>
Tool Kit, Electrical Repairer's	SC518099CLA06
Multimeter, Digital	AN/PSM-45

**Personnel Required:**

68X Armament/Electrical Systems Repairer  
One person to assist

**References:**

TM 55-1520-238-23

**Equipment Conditions:**

<u>Ref</u>	<u>Condition</u>
TM 55-1520-238-23	Access provisions - L60 fairing removed

---

<b>WARNING</b>
----------------

**Turn off power before detaching or attaching wires and connectors. High current 28 VDC or 115 VAC is present. Failure to do so could result in death or serious injury.**

1. Check for open between:

P747-d and J1039-A4,  
P747-e and J1039-A5.

**Does open exist?**

YES	Repair open wire. Go to paragraph 12-112.
NO	Go to step 2.

2. With the CPG master caution/warning **PRESS TO TEST** switch pressed, check for 28 VDC at J1039-A4 and J1039-A5.

**Is voltage present?**

YES	Replace CPG <b>ENG 2 FIRE PULL</b> handle switch (TM 55-1520-238-23).
NO	Replace multi-channel dimming controller (TM 55-1520-238-23).

END OF TASK

**12-1 17. PILOT AND CPG ENG 2 FIRE PULL HANDLES - DO NOT LIGHT WITH FIRE TEST SWITCH IN DET 1 POSITION**

**Tools:**

<u>Nomenclature</u>	<u>Part Number</u>
Tool Kit, Electrical Repairer's	SC518099CLA06
Multimeter, Digital	AN/PSM-45

**Personnel Required:**

68X Armament/Electrical Systems Repairer  
One person to assist

**References:**

TM 1-1520-238-T-6  
TM 55-1520-238-23

**Equipment Conditions:**

<u>Ref</u>	<u>Condition</u>
TM 55-1520-238-23	Access provisions - RN1 engine 2 (right) nacelle door open

**WARNING**

**Turn off power before detaching or attaching wires and connectors. High current 28 VDC or 115 VAC is present. Failure to do so could result in death or serious injury.**

1. Check for 28 VDC at P84-11.  
**Is voltage present?**

YES	Go to step 3.
NO	Go to step 2.

2. On pilot circuit breaker panel, check for 28 VDC at (A76)J1-G.  
**Is voltage present?**

YES	Repair open wire between P463-G and P84-11. Go to paragraph 12-112.
NO	Refer to TM 1-1520-238-T-6 to troubleshoot circuit protection system (dc emergency bus - pilot station).
3. Check for 28 VDC at P176-P.  
**Is voltage present?**

YES	Go to step 5.
NO	Go to step 4.
4. On pilot circuit breaker panel, check for 28 VDC at (A76)J1-F.  
**Is voltage present?**

YES	Repair open wire between P463-F and P176-P. Go to paragraph 12-112.
NO	Refer to TM 1-1520-238-T-6 to troubleshoot circuit protection system (dc emergency bus - pilot station).
5. With **FIRE TEST** switch held at **DET 1** position, check for 12.5 VDC minimum at P83-E.  
**Is voltage present?**

YES	Go to step 6.
NO	Go to step 7.
6. Check for open between P83-B and ground.  
**Does open exist?**

YES	Repair open wire. Go to paragraph 12-112.
NO	Go to step 8.

---

**12-1 17. PILOT AND CPG ENG 2 FIRE PULL HANDLES - DO NOT LIGHT WITH  
FIRE TEST SWITCH IN DET 1 POSITION (cont)**

---

12-1 17

7. With **FIRE TEST** switch held at **DET 1** position, check for  $4.7K \pm 470$  ohms between (A138): J1-P and J1-M.  
**Is proper voltage present?**
- |     |   |
|-----|---|
| YES | Repair open wire between P83-E and P176-M.<br>Go to paragraph 12-112. |
| NO  | Replace <b>FIRE TEST DET</b> switch (TM 55-1520-238-23).              |
8. With **FIRE TEST** switch held at **DET 1** position, check for 12.5 VDC minimum at P84-1.  
**Is voltage present?**
- |     |                |
|-----|----------------|
| YES | Go to step 10. |
| NO  | Go to step 9.  |
9. Check for open between P83-C and P84-1.  
**Does open exist?**
- |     |  |
|-----|--|
| YES | Repair open wire.<br>Go to paragraph 12-112.               |
| NO  | Replace engine 2 upper flame detector (TM 55-1520-238-23). |
10. With **FIRE TEST** switch held at **DET 1** position, check for open between P748-BB and ground.  
**Does open exist?**
- |     |   |
|-----|---|
| YES | Go to step 11.  |
| NO  | Replace multi-channel dimming controller (TM 55-1520-238-23). |
11. Check for open between P84-9 and P748-BB.  
**Does open exist?**
- |     |  |
|-----|--|
| YES | Repair open wire between.<br>Go to paragraph 12-112. |
| NO  | Go to step 12.                                       |
12. Check for open between P84-10 and GS541-C.  
**Does open exist?**
- |     |  |
|-----|--|
| YES | Repair open wire.<br>Go to paragraph 12-112.                   |
| NO  | Replace engine 2 flame detector amplifier (TM 55-1520-238-23). |

END OF TASK

**12-1 18. PILOT AND CPG ENG 2 FIRE PULL HANDLES - DO NOT LIGHT WITH FIRE TEST SWITCH IN DET 2 POSITION**

**Tools:**

<u>Nomenclature</u>	<u>Part Number</u>
Tool Kit, Electrical Repairer's	SC518099CLA06
Multimeter, Digital	AN/PSM-45

**Personnel Required:**

68X Armament/Electrical Systems Repairer  
One person to assist

**References:**

TM 1-1520-238-T-6  
TM 55-1520-238-23

**Equipment Conditions:**

<u>Ref</u>	<u>Condition</u>
TM 55-1520-238-23	Access provisions - RN1 engine 2 (right) nacelle door open

**WARNING**

**Turn off power before detaching or attaching wires and connectors. High current 28 VDC or 115 VAC is present. Failure to do so could result in death or serious injury.**

1. With **FIRE TEST** switch held at **DET 2** position, check for 28 VDC at P82-E.

**Is voltage present?**

- YES      Go to step 2.
- NO        Go to step 3.

2. Check for open between P82-B and ground.

**Does open exist?**

- YES      Repair open wire.  
            Go to paragraph 12-112.
- NO        Go to step 4.

3. With **FIRE TEST** switch held at **DET 2** position, check for 4.7K ±470 ohms between (A138): J1-P and J1-N.

**Is proper voltage present?**

- YES      Repair open wire between P82-E and P176-N.  
            Go to paragraph 12-112.
- NO        Replace **FIRE TEST** switch (TM 55-1520-238-23).

4. With **FIRE TEST** switch held at **DET 2** position, check for 12.5 VDC minimum at P84-2.

**Is voltage present?**

- YES      Replace engine 2 flame detector amplifier (TM 55-1520-238-23).
- NO        Go to step 8.

5. Check for open between P82-C and P84-2.

**Does open exist?**

- YES      Repair open wire.  
            Go to paragraph 12-112.
- NO        Replace engine 2 lower flame detector (TM 55-1520-238-23).

END OF TASK

---

**12-1 19. PILOT AND CPG ENG 2 FIRE PULL HANDLES - DO NOT LIGHT  
(UPPER FLAME DETECTOR LENS)**

---

12-1 19

**Tools:**

<u>Nomenclature</u>	<u>Part Number</u>
Tool Kit, Electrical Repairer's	SC518099CLA06
Multimeter, Digital	AN/PSM-45

**Personnel Required:**

68X Armament/Electrical Systems Repairer  
One person to assist

**References:**

TM 1-1520-238-23

**Equipment Conditions:**

<u>Ref</u>	<u>Condition</u>
TM 1-1520-238-23	Access provisions - RN1 engine 2 (right) nacelle door open

---

<b>WARNING</b>
----------------

**Turn off power before detaching or attaching wires and connectors. High current 28 VDC or 115 VAC is present. Failure to do so could result in death or serious injury.**

1. Check for 28 VDC at P83-A.

**Is voltage present?**

YES	Go to step 2.
NO	Repair open wire between P83-A and J214 SP1. Go to paragraph 12-112.

2. Shine a red-filtered light source on engine 2 upper flame detector lens. Check for a minimum of 12.5 VDC at P84-1.

**Is proper voltage present?**

YES	Replace engine 2 flame detector amplifier (TM 1-1520-238-23).
NO	Replace engine 2 upper flame detector (TM 1-1520-238-23).

END OF TASK

**12-120. PILOT AND CPG ENG 2 FIRE PULL HANDLES - DO NOT LIGHT  
(LOWER FLAME DETECTOR LENS)**

**12-120**

**Tools:**

<u>Nomenclature</u>	<u>Part Number</u>
Tool Kit, Electrical Repairer's	SC518099CLA06
Multimeter, Digital	AN/PSM-45

**Personnel Required:**

68X Armament/Electrical Systems Repairer  
One person to assist

**References:**

TM 1-1520-238-23

**Equipment Conditions:**

<u>Ref</u>	<u>Condition</u>
TM 1-1520-238-23	Access provisions - RN1 engine 2 (right) nacelle door open

- Shine a red-filtered light source on engine 2 lower flame detector lens. Check for a minimum of 12.5 VDC at P84-2.

**Is proper voltage present?**

YES	Replace engine 2 flame detector amplifier (TM 1-1520-238-23).
NO	Replace engine 2 lower flame detector (TM 1-1520-238-23).

**WARNING**

**Turn off power before detaching or attaching wires and connectors. High current 28 VDC or 115 VAC is present. Failure to do so could result in death or serious injury.**

- Check for 28 VDC at P82-A.

**Is voltage present?**

YES	Go to step 2.
NO	Repair open wire between P82-A and J214 SP1. Go to paragraph 12-112.

END OF TASK

12-121. APU FIRE DETECTION - POWER UP

12-121

**Tools:**

Nomenclature	Part Number
Tool Kit, Electrical Repairer's	SC518099CLA06

**Equipment Conditions:**

Ref	Condition
TM 55-1520-238-23	Helicopter safed External power application - Electrical APU fire detection system inspection completed

**Personnel Required:**

68X Armament/Electrical Systems Repairer

**References:**

TM 55-1520-238-23

**NOTE**

Refer to pilot station (fig. 12-98) and CPG station (fig. 12-99) for cockpit configuration and equipment.

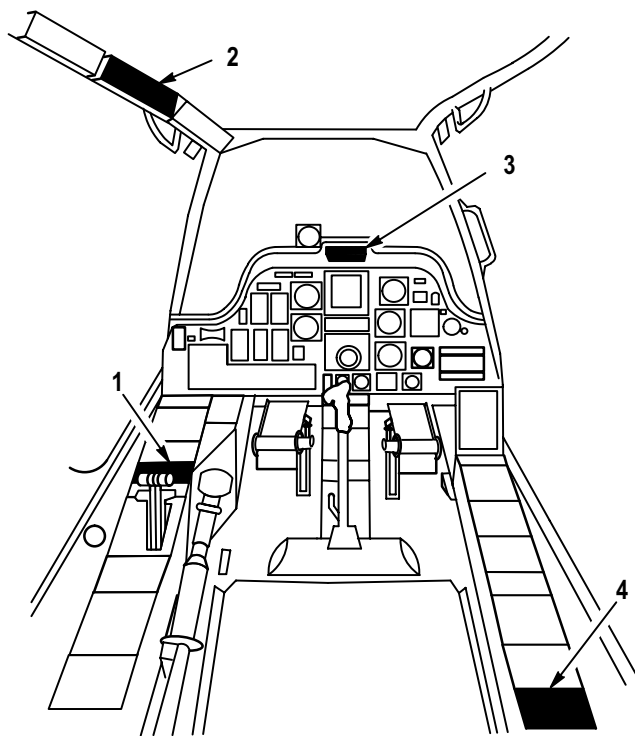

- 1. PILOT ELEC PWR PANEL
- 2. PILOT CENTER CIRCUIT BREAKER PANEL
- 3. PILOT MASTER CAUTION/WARNING PANEL
- 4. PILOT APU FIRE TEST PANEL

M71-112A

Figure 12-98. Pilot Station

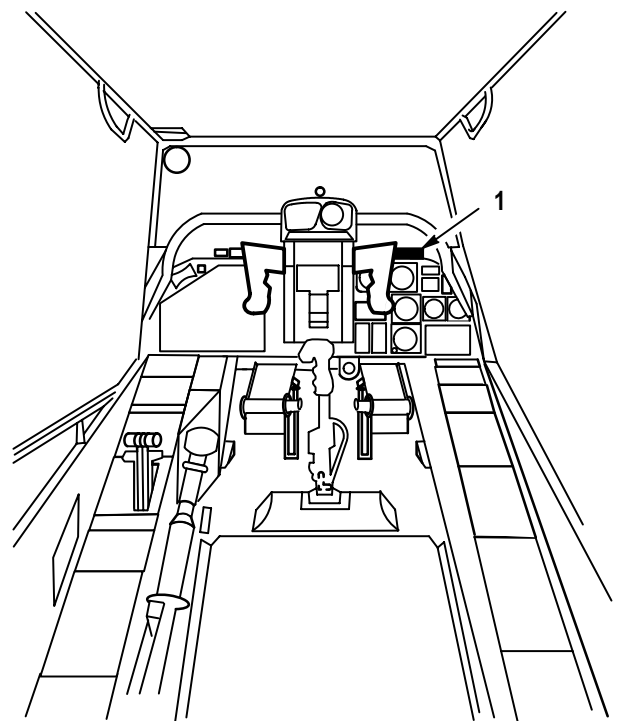

- 1. CPG MASTER CAUTION/WARNING PANEL

M71-113

Figure 12-99. CPG Station

1. On pilot center circuit breaker panel (fig. 12-100), check that the following circuit breakers are closed:

Circuit Breaker

**FIRE DETR ENG 1**

**FIRE DETR APU**

**LT PRI**

**LT CAUT**

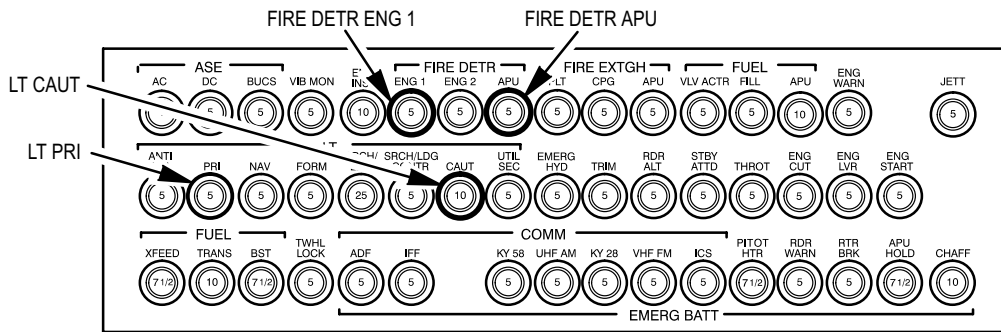

M71-114

**Figure 12-100. Pilot Center Circuit Breaker Panel**

2. On pilot **ELEC PWR** panel (fig. 12-101), set **BATT/EXT PWR** switch to **EXT PWR**.

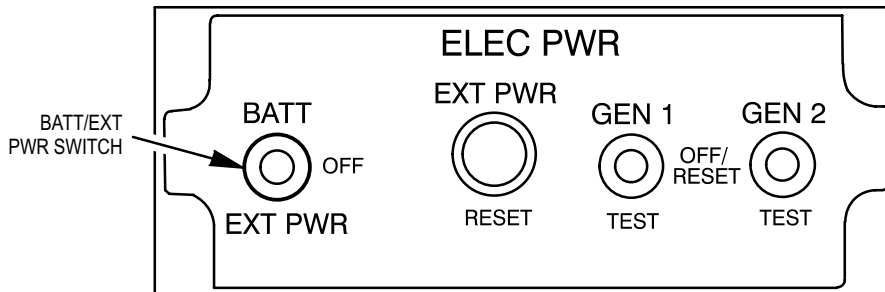

M71-115

**Figure 12-101. Pilot ELEC PWR Panel**

END OF TASK



---

**12-122. APU FIRE DETECTION - POWER DOWN**

---

12-122

**Tools:**

<u>Nomenclature</u>	<u>Part Number</u>
Tool Kit, Electrical Repairer's	SC518099CLA06

**References:**

TM 55-1520-238-23

**Equipment Conditions:**

<u>Ref</u>	<u>Condition</u>
Paragraph 12-121	APU FIRE DETECTION - POWER UP completed

**Personnel Required:**68X Armament/Electrical Systems Repairer

---

**NOTE**

**Refer to pilot station (fig. 12-98) and CPG station (fig. 12-99) for cockpit configuration and equipment.**

1. On pilot center circuit breaker panel (fig. 12-100), open the following circuit breakers.

Circuit Breaker**FIRE DETR ENG 1****FIRE DETR APU****LT PRI****LT CAUT**

2. On pilot **ELEC PWR** panel (fig. 12-101), set **BATT/EXT PWR** switch to **OFF**.
3. Remove external power - electrical (TM 55-1520-238-23).

END OF TASK

12-123. APU FIRE DETECTION - MAINTENANCE OPERATIONAL CHECK

12-123

**Tools:**

<u>Nomenclature</u>	<u>Part Number</u>
Tool Kit, Electrical Repairer's	SC518099CLA06

**Equipment Conditions:**

<u>Ref</u>	<u>Condition</u>
TM 55-1520-238-23	Access provisions - deck doors T250R, T250L, T290R, T290L and L325 opened
Paragraph 12-121	APU FIRE DETECTION - POWER UP completed
TM 1-1520-238-T-4	Maintenance headset connected

**Personnel Required:**

68X Armament/Electrical Systems Repairer

**References:**

TM 1-1520-238-T-4  
 TM 1-1520-238-T-6  
 TM 55-1520-238-23

**NOTE**

- Refer to pilot station (fig. 12-98) and CPG station (fig. 12-99) for cockpit configuration and equipment.
- If referenced out of one paragraph or volume into another for additional troubleshooting, upon completion of the task, return to the maintenance operational check for the original paragraph or volume.

1. Perform the maintenance operational check as follows:

<u>Task</u>	<u>Result</u>
a. On pilot center circuit breaker panel (fig. 12-100), check that <b>FIRE DETR ENG 1</b> and <b>FIRE DETR APU</b> circuit breakers are closed.	If <b>FIRE DETR ENG 1</b> circuit breaker does not stay closed, go to paragraph 12-103.  If <b>FIRE DETR APU</b> circuit breaker does not stay closed, go to paragraph 12-125.
b. On pilot master caution/warning panel (fig. 12-102), press and hold the <b>PRESS TO TEST</b> switch.	If <b>APU FIRE PULL</b> handle on pilot <b>APU</b> fire test panel (fig. 12-103) does not light, replace lamp (TM 55-1520-238-23). If lamp still does not light, go to paragraph 12-126.  If pilot <b>FIRE APU</b> indicator does not light, check and replace lamp (TM 55-1520-238-23). If lamp still does not light, refer to TM 1-1520-238-T-6 to troubleshoot pilot caution/warning system.  If CPG <b>FIRE APU</b> indicator lights, go to paragraph 12-128.

12-123. APU FIRE DETECTION - MAINTENANCE OPERATIONAL CHECK (cont)

12-123

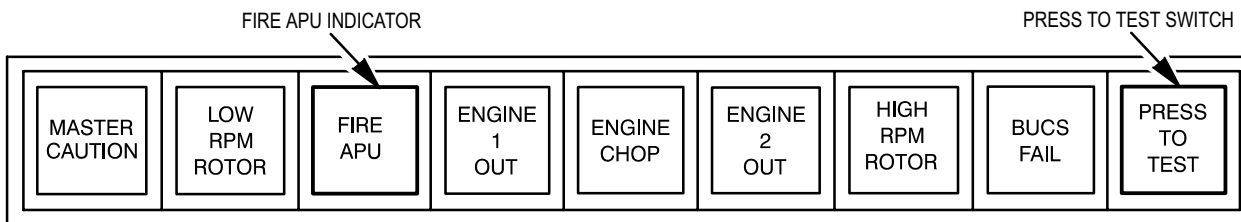

M71-116

Figure 12-102. Master Caution/Warning Panel

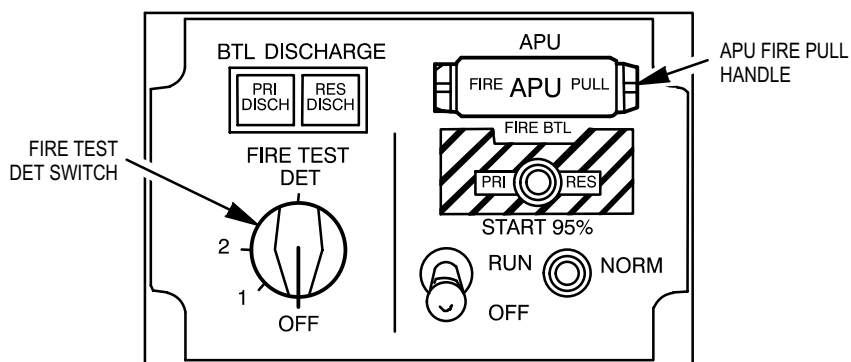

M71-117A

Figure 12-103. Pilot APU Fire Test Panel

Task	Result
c. On CPG master caution/warning panel (fig. 12-102), press and hold the <b>PRESS TO TEST</b> switch.	If CPG <b>FIRE APU</b> indicator does not light, replace lamp (TM 55-1520-238-23). If lamp still does not light, refer to TM 1-1520-238-T-6 to troubleshoot CPG caution/warning system.
d. On pilot <b>APU</b> fire test panel (fig. 12-103), hold <b>FIRE TEST DET</b> switch at 1.	If <b>APU FIRE PULL</b> handle does not light, go to paragraph 12-129.  If pilot <b>FIRE APU</b> indicator does not light, refer to TM 1-1520-238-T-6 to troubleshoot pilot caution/warning system.
e. Hold <b>FIRE TEST DET</b> switch at 2.	If CPG <b>FIRE APU</b> indicator does not light, go to paragraph 12-127.
f. Release <b>FIRE TEST DET</b> switch, allowing it to return to <b>OFF</b> .	If <b>APU FIRE PULL</b> handle does not light, go to paragraph 12-130.

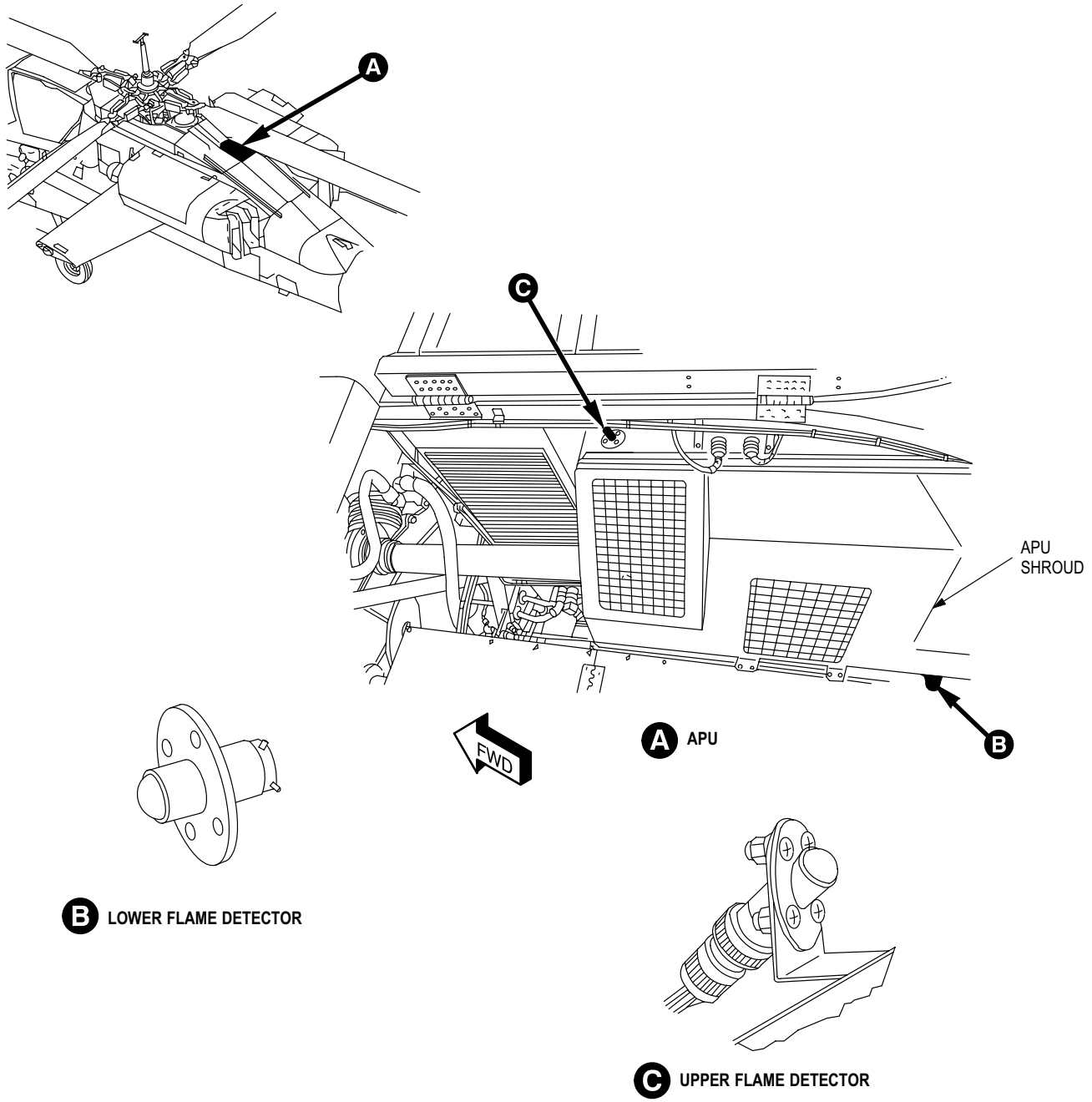

Figure 12-104. Upper and Lower Flame Detectors

M71-118

12-123. APU FIRE DETECTION - MAINTENANCE OPERATIONAL CHECK (cont)

12-123

Task	Result
------	--------

**NOTE**

**Place helicopter in shade or indoors during maintenance operational check of flame detectors. Prevent direct illumination of flame detector not being checked.**

- |   |   |
|---|---|
| <p>g. Shine flashlight with a red filter on APU upper flame detector lens (fig. 12-104).</p>  | <p>If <b>APU FIRE PULL</b> handle does not light, replace upper flame detector (TM 55-1520-238-23).</p> |
| <p>h. Shine flashlight with a red filter on APU upper flame detector lens. Check that <b>FIRE APU</b> indicators on pilot and CPG master caution/warning panels are lighted. On the pilot master caution/warning panel press and hold the <b>PRESS TO TEST</b> switch. Check that the CPG <b>FIRE APU</b> indicator is off.</p> | <p>If CPG <b>FIRE APU</b> indicator does not go out, go to paragraph 12-128.</p>                        |
| <p>i. Shine flashlight with no filter on APU upper flame detector lens.</p>   | <p>If <b>APU FIRE PULL</b> handle lights, replace upper flame detector (TM 55-1520-238-23).</p>         |
| <p>j. Shine flashlight with a red filter on APU lower flame detector lens.</p>  | <p>If <b>APU FIRE PULL</b> handle does not light, replace lower flame detector (TM 55-1520-238-23).</p> |
| <p>k. Shine flashlight with no filter on APU lower flame detector lens.</p>   | <p>If <b>APU FIRE PULL</b> handle lights, replace lower flame detector (TM 55-1520-238-23).</p>         |

2. Perform APU FIRE DETECTION - POWER DOWN (para 12-122).
3. Secure deck doors T250R, T250L, T290R, T290L and L325 (TM 55-1520-238-23).
4. Disconnect maintenance headset (TM 1-1520-238-T-4).

END OF TASK

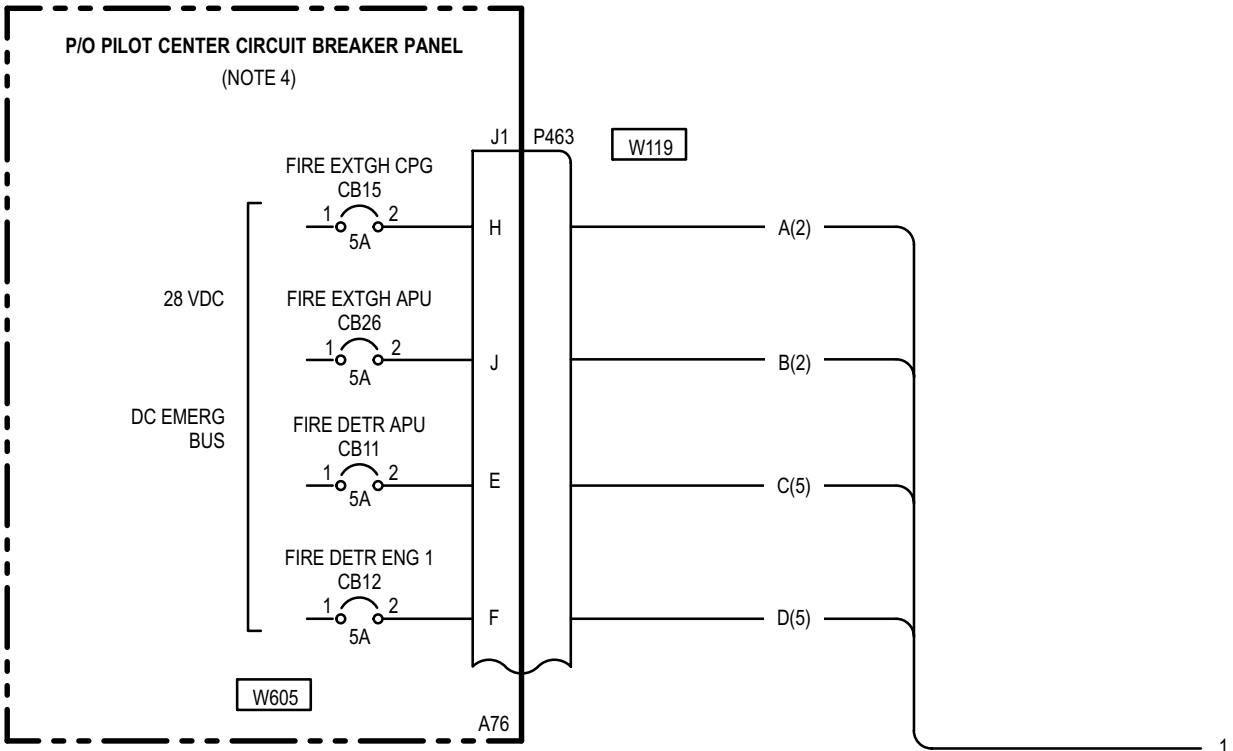

12-124. APU FIRE DETECTION - WIRING INTERCONNECT DIAGRAM (cont)

12-124

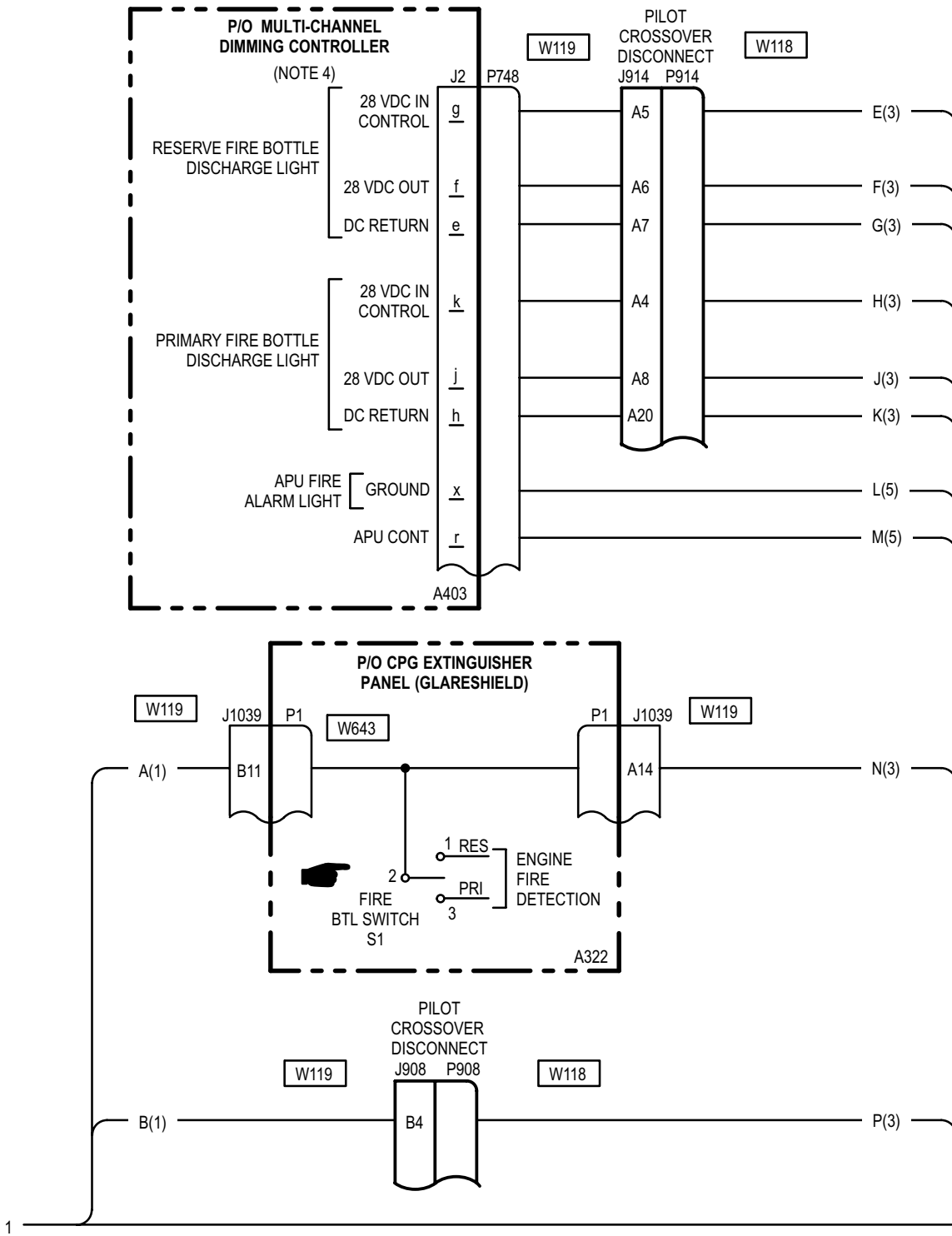

M71-222-2B  
 SHEET 2 OF 7

12-124. APU FIRE DETECTION - WIRING INTERCONNECT DIAGRAM (cont)

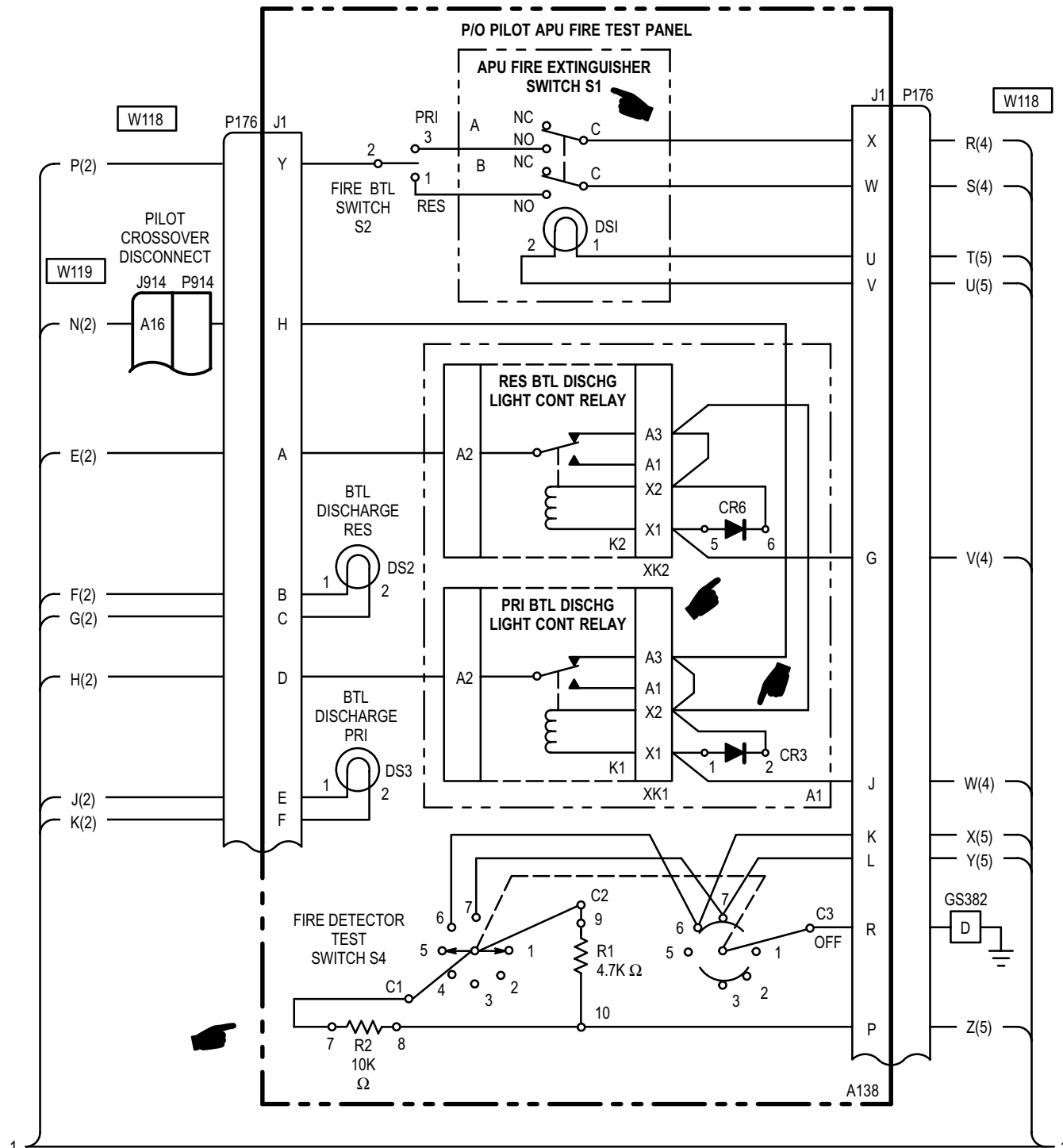



12-124. APU FIRE DETECTION - WIRING INTERCONNECT DIAGRAM (cont)

12-124

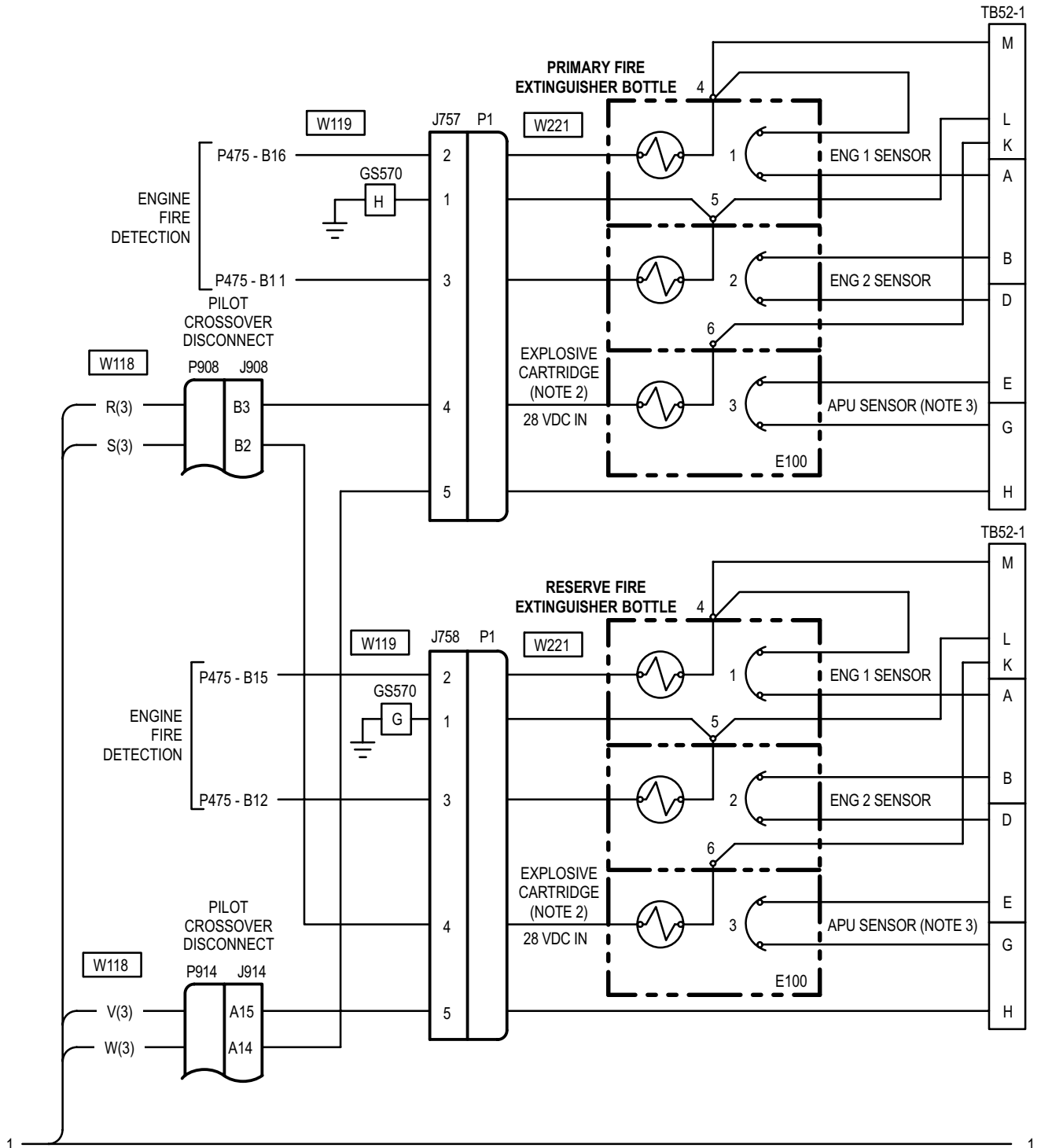

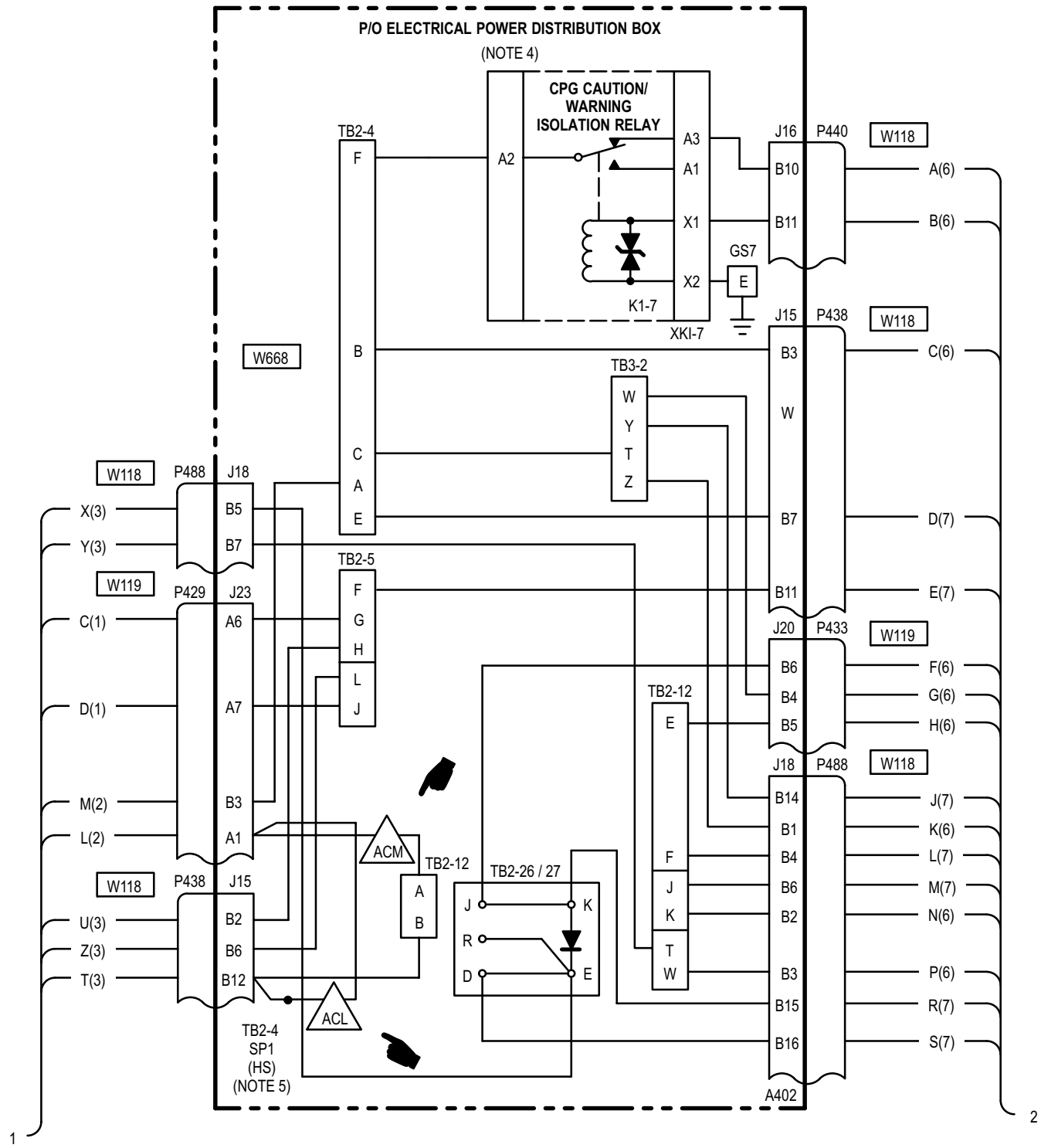

1

2

12-124. APU FIRE DETECTION - WIRING INTERCONNECT DIAGRAM (cont)

12-124

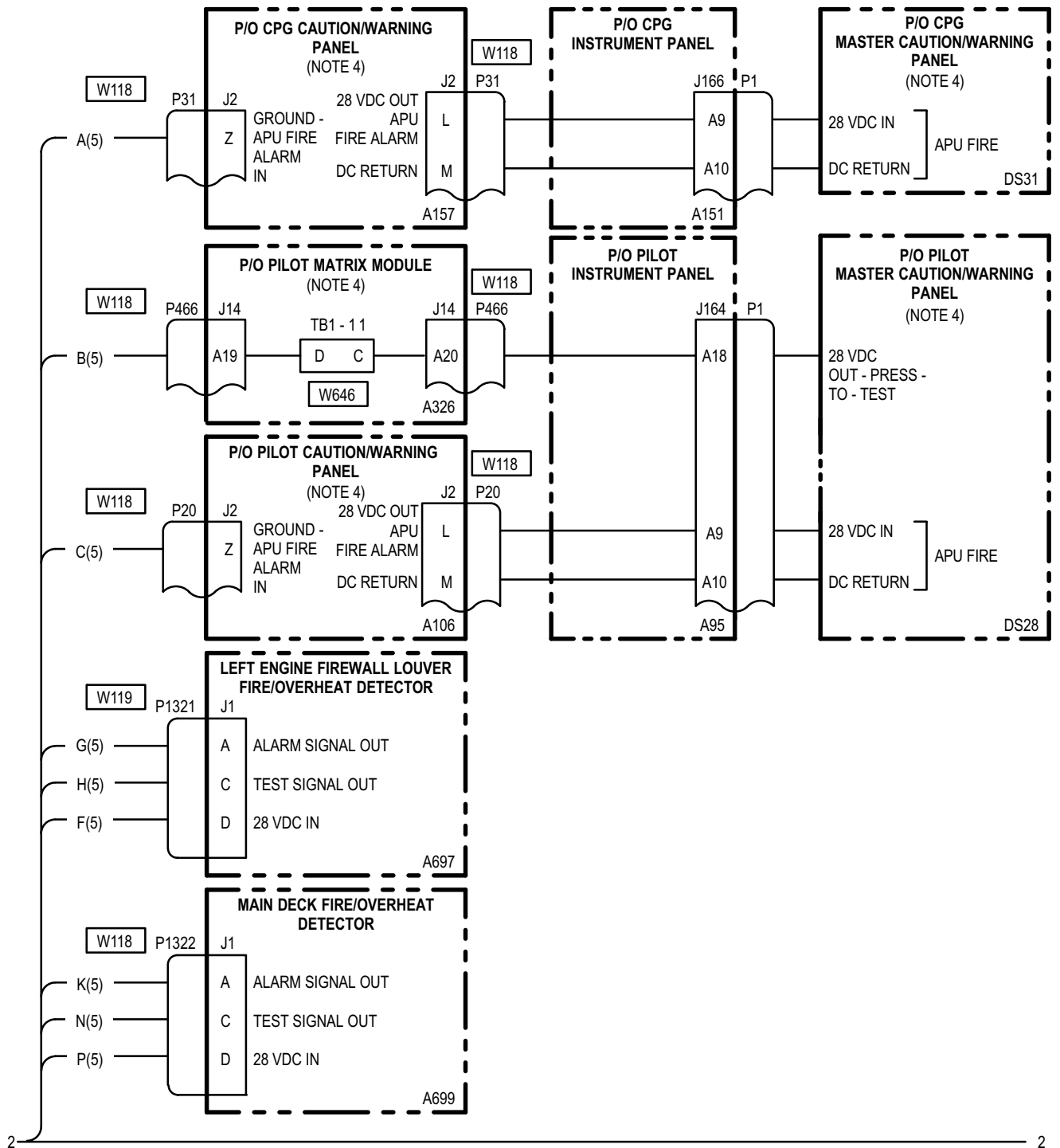

2

2

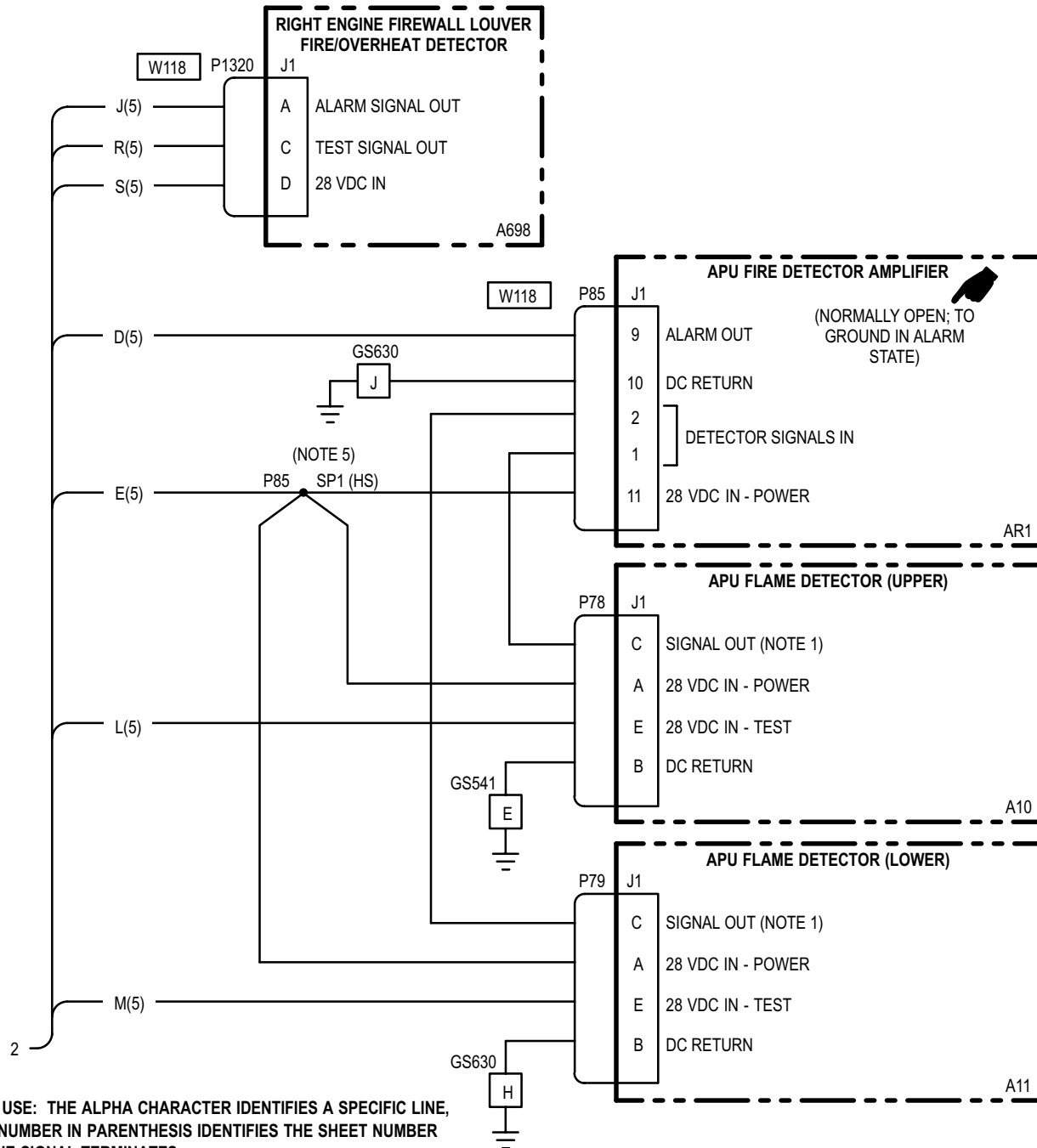

**NOTES:**

HIGHWAY USE: THE ALPHA CHARACTER IDENTIFIES A SPECIFIC LINE, AND THE NUMBER IN PARENTHESIS IDENTIFIES THE SHEET NUMBER WHERE THE SIGNAL TERMINATES.

1. FLAME DETECTOR OUTPUT - 12.5 VDC MIN.
2. ELECTRICALLY ACTUATED.
3. OPENS AFTER BOTTLE DISCHARGES.
4. ELECTRICAL SYSTEM (TM 1-1520-238-T-6).
5. HS DESIGNATES A HARD SPLICE WHICH CANNOT BE DISCONNECTED.  
 M DESIGNATES A SOFT SPLICE WHICH MAY BE DISCONNECTED FOR A WIRING CHECK.

**12-125. FIRE DETR APU CIRCUIT BREAKER (CB11) - DOES NOT STAY CLOSED**

**12-125**

**Tools:**

<u>Nomenclature</u>	<u>Part Number</u>
Tool Kit, Electrical Repairer's	SC518099CLA06
Multimeter, Digital	AN/PSM-45

**Personnel Required:**

68X Armament/Electrical Systems Repairer

**References:**

TM 1-1520-238-T-6  
 TM 55-1520-238-23

**WARNING**

**Turn off power before detaching or attaching wires and connectors. High current 28 VDC or 115 VAC is present. Failure to do so could result in death or serious injury.**

1. Open **FIRE DETR APU** circuit breaker (CB11). Check for short between (A76)J1-E and ground.  
**Does short exist?**

YES	Refer to TM 1-1520-238-T-6 to troubleshoot circuit protection system (dc emergency bus - pilot station).
NO	Go to step 2.

2. Detach wire from (A402)TB2-5-G. Check for short between P463-E and ground.  
**Does short exist?**

YES	Repair shorted wire between: P463-E and P429-6. (A402): J23-A6 and TB2-5-G. Go to paragraph 12-123.
NO	Go to step 3.

3. With wire from (A402)TB2-5-H detached, check for short between wire end at (A402)TB2-5-H and ground.

**Does short exist?**

YES	Go to step 4.
NO	Go to step 5.

4. With wire detached from (A402)TB2-5-H, check for short between P176-V and ground.

**Does short exist?**

YES	Repair shorted wire between: P438-B2 and P176-V. (A402): TB2-5-H and J15-B2. Go to paragraph 12-123.
NO	Replace pilot <b>APU</b> fire test panel (TM 55-1520-238-23).

5. Detach P78, P79 and P85. Check for short between (A402)TB2-5-F and ground.

**Does short exist?**

YES	Repair shorted wire between: P438-B11 and P85-11, P438-B11 and P78-A, P438-B11 and P79-A. (A402): TB2-5-F and J15-B11. Go to paragraph 12-123.
NO	Go to step 6.

6. Attach P78. Check for short between (A402)TB2-5-F and ground.

**Does short exist?**

YES	Replace APU flame detector (upper) (TM 55-1520-238-23).
NO	Go to step 7.

7. Attach P79. Check for short between (A402)TB2-5-F and ground.

**Does short exist?**

YES	Replace APU flame detector (lower) (TM 55-1520-238-23).
NO	Replace APU flame detector amplifier (TM 55-1520-238-23).

END OF TASK

12-126. APU FIRE PULL HANDLE - DOES NOT LIGHT

**Tools:**

<u>Nomenclature</u>	<u>Part Number</u>
Tool Kit, Electrical Repairer's	SC518099CLA06
Multimeter, Digital	AN/PSM-45

**Personnel Required:**

68X Armament/Electrical Systems Repairer  
One person to assist

**References:**

TM 1-1520-238-T-6  
TM 55-1520-238-23



**Turn off power before detaching or attaching wires and connectors. High current 28 VDC or 115 VAC is present. Failure to do so could result in death or serious injury.**

1. Close **FIRE DETR APU** circuit breaker (CB11). Check for 28 VDC at P176-V.

**Is voltage present?**

- YES Go to step 3.
- NO Go to step 2.

2. On pilot circuit breaker panel, check for 28 VDC at (A76)J1-E.

**Is voltage present?**

- YES Repair open wire between: P429-A6 and P463-E, P176-V and P438-B2. (A402): J15-B2 and TB2-5-H, TB2-5-G and J23-A6. Go to paragraph 12-123.
- NO Refer to TM 1-1520-238-T-6 to troubleshoot circuit protection system (dc emergency bus - pilot station).

3. On pilot master caution/warning panel, press and hold **PRESS-TO-TEST** switch. Check for open between (A402)TB2-4-A and ground.

**Does open exist?**

- YES Go to step 4.
- NO Go to step 5.

4. Check for open between: P429-B3 and P748-r.

(A402):  
TB2-4-A and J23-B3.

**Does open exist?**

- YES Repair open wire. Go to paragraph 12-123.
- NO Replace multi-channel dimming controller (TM 55-1520-238-23).

5. Check for open between: P438-B12 and P176-U.

(A402):  
J23-A1 and J15-B12.

**Does open exist?**

- YES Repair open wire. Go to paragraph 12-123.
- NO Replace **APU** fire test panel (TM 55-1520-238-23).

END OF TASK

---

**12-127. CPG FIRE APU INDICATOR - DOES NOT LIGHT WITH FIRE TEST SWITCH  
IN DET 1 POSITION**

---

12-127

**Tools:**

<u>Nomenclature</u>	<u>Part Number</u>
Tool Kit, Electrical Repairer's	SC518099CLA06
Multimeter, Digital	AN/PSM-45

**Personnel Required:**

68X Armament/Electrical Systems Repairer  
One person to assist

**References:**

TM 1-1520-238-T-6  
TM 55-1520-238-23

---

<b>WARNING</b>
----------------

**Turn off power before detaching or attaching wires and connectors. High current 28 VDC or 115 VAC is present. Failure to do so could result in death or serious injury.**

- Check for 28 VDC at P78-E.  
**Is voltage present?**

YES	Go to step 8.
NO	Go to step 2.
- Check for 28 VDC at P176-P.  
**Is voltage present?**

YES	Go to step 3.
NO	Go to step 7.
- With **FIRE TEST** switch at **DET 1**, check for 10K  $\pm$ 1K ohms between (A138): J1-K and J1-P.  
**Is resistance present?**

YES	Go to step 4.
NO	Replace <b>APU</b> fire test panel (TM 55-1520-238-23).
- Check for open between: P176-K and (A402)TB2-26/27-E, P1320-D and (A402)TB2-26/27-D, P1320-C and (A402)TB2-26/27-K, P1321-C and (A402)TB2-12-E, P1321-D and (A402)TB2-26/27-J, P78-E and (A402)TB2-12-F.  
**Does open exist?**

YES	Repair open wire. Go to paragraph 12-123.
NO	Go to step 5.
- Check for open between (A402): TB2-26/27-E and TB2-26/27-D, TB2-26/27-K and TB2-26/27-J.  
**Does open exist?**

YES	Replace terminal board (A402)TB2-26/27 (TM 55-1520-238-23).
NO	Go to step 6.
- Check for open between (A698): J1-C and J1-D.  
**Does open exist?**

YES	Replace right engine firewall louver fire/overheat detector (TM 55-1520-238-23).
NO	Replace left engine firewall louver fire/overheat detector (TM 55-1520-238-23).
- Check for 28 VDC at (A76)J1-F.  
**Is voltage present?**

YES	Repair open wire between: P176-P and P438-B6, P429-A7 and P463-F. (A402): J15-B6 and TB2-5-L, TB2-5-J and J23-A7. Go to paragraph 12-123.
NO	Refer to TM 1-1520-238-T-6 to troubleshoot circuit protection system (dc emergency bus - pilot station).

**12-127. CPG FIRE APU INDICATOR - DOES NOT LIGHT WITH FIRE TEST SWITCH  
IN DET 1 POSITION (cont)**

- |   |   |
|---|---|
| <p>8. Check for 12.5 VDC (minimum) at P85-1.<br/><b>Is voltage present?</b></p> <p>YES      Go to step 10.</p> <p>NO        Go to step 9.</p> <p>9. Check for open between:<br/>P85-1 and P78-C<br/>P78-B and ground.<br/><b>Does open exist?</b></p> <p>YES      Repair open wire.<br/>            Go to paragraph 12-123.</p> <p>NO        Replace upper APU flame<br/>            detector (TM 55-1520-238-23).</p> <p>10. Check for open between P85-10 and ground.<br/><b>Does open exist?</b></p> <p>YES      Repair open wire.<br/>            Go to paragraph 12-123.</p> <p>NO        Go to step 11.</p> <p>11. Check for open between P31-Z and P85-9.<br/><b>Does open exist?</b></p> <p>YES      Go to step 13.</p> <p>NO        Go to step 12.</p> <p>12. With wire end removed from (A402)TB2-4-F,<br/>check for 28 VDC.<br/><b>Is voltage present?</b></p> <p>YES      Replace APU flame detector<br/>            amplifier (TM 55-1520-238-23).</p> <p>NO        Refer to TM 1-1520-238-T-6 to<br/>            troubleshoot CPG<br/>            caution/warning system.</p> <p>13. Check for open between:<br/>P440-B10 and P31-Z,<br/>P438-B7 and P85-9.<br/><b>Does open exist?</b></p> <p>YES      Repair open wire.<br/>            Go to paragraph 12-123.</p> <p>NO        Go to step 14.</p> | <p>14. Check for open between (A402):<br/>TB2-4-F and XK1-7-A2,<br/>K1-7-A3 and J16-B10,<br/>TB2-4-E and J15-B7.<br/><b>Does open exist?</b></p> <p>YES      Repair open wire.<br/>            Go to paragraph 12-123.</p> <p>NO        Replace relay (A402)K1-7<br/>            (TM 55-1520-238-23).</p> |
|---|---|

END OF TASK



**12-128. CPG FIRE APU INDICATOR - LIGHTS WHEN PILOT MASTER  
PRESS TO TEST SWITCH IS PRESSED**

12-128

**Tools:**

<u>Nomenclature</u>	<u>Part Number</u>
Tool Kit, Electrical Repairer's	SC518099CLA06
Multimeter, Digital	AN/PSM-45

**Personnel Required:**

68X Armament/Electrical Systems Repairer  
One person to assist

**References:**

TM 55-1520-238-23

3. Check for open between (A402):  
J16-B11 and XK1-7-X1,  
GS7-E and XK1-7-X2.

**Does open exist?**

YES	Repair open wire. Go to paragraph 12-123.
NO	Replace CPG caution/warning isolation relay (A402)K1-7 (TM 55-1520-238-23).

**WARNING**

**Turn off power before detaching or  
attaching wires and connectors. High  
current 28 VDC or 115 VAC is present.  
Failure to do so could result in death or  
serious injury.**

1. Check for 28 VDC at P440-B11.  
**Is voltage present?**

YES	Go to step 3.
NO	Go to step 2.

2. Check for open between P440-B11 and  
J164-A18.

**Does open exist?**

YES	Repair open wire. Go to paragraph 12-123.
NO	Replace pilot master caution/warning panel (TM 55-1520-238-23).

END OF TASK

**12-129. APU FIRE PULL HANDLE - DOES NOT LIGHT WITH FIRE TEST SWITCH  
IN DET 1 POSITION**

12-129

**Tools:**

<u>Nomenclature</u>	<u>Part Number</u>
Tool Kit, Electrical Repairer's	SC518099CLA06
Multimeter, Digital	AN/PSM-45

**Personnel Required:**

68X Armament/Electrical Systems Repairer  
One person to assist

**References:**

TM 1-1520-238-T-6  
TM 55-1520-238-23

**Equipment Conditions:**

<u>Ref</u>	<u>Condition</u>
TM 55-1520-238-23	Access provisions - T250L, T250R, T290L, T290R, and L325 doors opened.

**WARNING**

**Turn off power before detaching or attaching wires and connectors. High current 28 VDC or 115 VAC is present. Failure to do so could result in death or serious injury.**

1. With **FIRE DETR APU** circuit breaker (CB11) closed, check for 28 VDC at P85-11 and P78-A.  
**Is voltage present?**
  - YES Go to step 2.
  - NO Go to step 11.
  
2. With **FIRE DETR ENG 1** circuit breaker closed and **FIRE TEST** switch at **DET 1**, check for 28 VDC at P78-E.  
**Is voltage present?**
  - YES Go to step 3.
  - NO Go to step 6.

3. With **FIRE TEST** switch at **DET 1**, check for minimum of 12.5 VDC at P85-1.  
**Is voltage present?**
  - YES Go to step 5.
  - NO Go to step 4.
  
4. Check for open between P78-C and P85-1.  
**Does open exist?**
  - YES Repair open wire.  
Go to paragraph 12-123.
  - NO Replace APU upper flame detector (TM 55-1520-238-23).
  
5. Check for open between: P85-9 and P438-B7.  
(A402): J15-B7 and TB2-4-E.  
**Does open exist?**
  - YES Repair open wire.  
Go to paragraph 12-123.
  - NO Replace APU flame detector amplifier (TM 55-1520-238-23).
  
6. On pilot circuit breaker panel, check for 28 VDC at J1-F.  
**Is voltage present?**
  - YES Go to step 7.
  - NO Refer to TM 1-1520-238-T-6 to troubleshoot circuit protection system (dc emergency bus - pilot station).
  
7. On pilot **APU** fire test panel, set **FIRE TEST** switch at **DET**, check for 10K ±1K ohms resistance between (A138): J1-P and J1-K.  
**Is resistance present?**
  - YES Go to step 8.
  - NO Replace **APU** fire test panel (TM 55-1520-238-23).

---

**12-129. APU FIRE PULL HANDLE - DOES NOT LIGHT WITH FIRE TEST SWITCH  
IN DET 1 POSITION (cont)**

---

12-129

8. Check for open between:  
P176-K and (A402)TB2-26/27-E,  
P1320-D and (A402)TB2-26/27-D,  
P1320-C and (A402)TB2-26/27-K,  
P1321-C and (A402)TB2-12-E,  
P1321-D and (A402)TB2-26/27-J,  
P78-E and (A402)TB2-12-F.  
**Does open exist?**
- |     |  |
|-----|--|
| YES | Repair open wire.<br>Go to paragraph 12-123. |
| NO  | Go to step 9.                                |
9. Check for open between (A402):  
TB2-26/27-E and TB2-26/27-D,  
TB2-26/27-K and TB2-26/27-J.  
**Does open exist?**
- |     |   |
|-----|---|
| YES | Replace terminal board<br>(A402)TB2-26/27<br>(TM 55-1520-238-23). |
| NO  | Go to step 10.  |
10. Check for open between (A698):  
J1-C and J1-D.  
**Does open exist?**
- |     |  |
|-----|--|
| YES | Replace right engine firewall<br>louver fire/overheat detector<br>(TM 55-1520-238-23). |
| NO  | Replace left engine firewall<br>louver fire/overheat detector<br>(TM 55-1520-238-23).  |
11. On pilot circuit breaker panel, check for 28 VDC  
at J1-E.  
**Is voltage present?**
- |     |   |
|-----|---|
| YES | Go to step 12.  |
| NO  | Refer to TM 1-1520-238-T-6 to<br>troubleshoot circuit protection<br>system (dc emergency bus -<br>pilot station). |
12. Check for open between (A402):  
J23-A6 and J15-B11.  
**Does open exist?**
- |     |   |
|-----|---|
| YES | Repair open wire between<br>(A402):<br>J23-A6 and J15-B11.<br>Go to paragraph 12-123.   |
| NO  | Repair open wire between:<br>P438-B11 and P85-11,<br>P438-B11 and P78-A,<br>P438-B11 and P79-A,<br>P463-E and P429-A6.<br>Go to paragraph 12-123. |

END OF TASK

**12-130. APU FIRE PULL HANDLE - DOES NOT LIGHT WITH FIRE TEST SWITCH  
IN DET 2 POSITION**

**12-130**

**Tools:**

<u>Nomenclature</u>	<u>Part Number</u>
Tool Kit, Electrical Repairer's	SC518099CLA06
Multimeter, Digital	AN/PSM-45

**Personnel Required:**

68X Armament/Electrical Systems Repairer  
One person to assist

**References:**

TM 55-1520-238-23



**Turn off power before detaching or attaching wires and connectors. High current 28 VDC or 115 VAC is present. Failure to do so could result in death or serious injury.**

1. Check for 28 VDC at P79-E.  
**Is voltage present?**

YES      Go to step 4.  
NO        Go to step 2.

2. Check for open between:  
P176-L and P488-B7,  
P488-B3 and P1322-D,  
P488-B6 and P79-E.  
(A402):  
J18-B6 and TB2-12-J,  
J18-B2 and TB2-12-K,  
J18-B3 and TB2-12-W,  
J18-B7 and TB2-12-T.

**Does open exist?**

YES      Repair open wire.  
            Go to paragraph 12-123.  
  
NO        Go to step 3.

3. Check for open between (A699):  
J1-D and J1-C.

**Does open exist?**

YES      Replace fire/overheat deck  
            detector (TM 55-1520-238-23).  
  
NO        Replace pilot **APU** fire test panel  
            (TM 55-1520-238-23).

4. Check for open between:  
P79-C and P85-2,  
P79-B and ground.

**Does open exist?**

YES      Repair open wire.  
            Go to paragraph 12-123.  
  
NO        Replace APU lower flame  
            detector (TM 55-1520-238-23).

END OF TASK

12-131. FIRE EXTINGUISHERS - POWER UP

12-131

**Tools:**

Nomenclature	Part Number
Tool Kit, Electrical Repairer's	SC518099CLA06

**Equipment Conditions:**

Ref	Condition
TM 55-1520-238-23	Helicopter safed External power application - Electrical - Pressurized air

**Personnel Required:**

68X Armament/Electrical Systems Repairer

**References:**

TM 55-1520-238-23

**NOTE**

Refer to pilot station (fig. 12-105) and CPG station (fig. 12-106) for cockpit configuration and equipment.

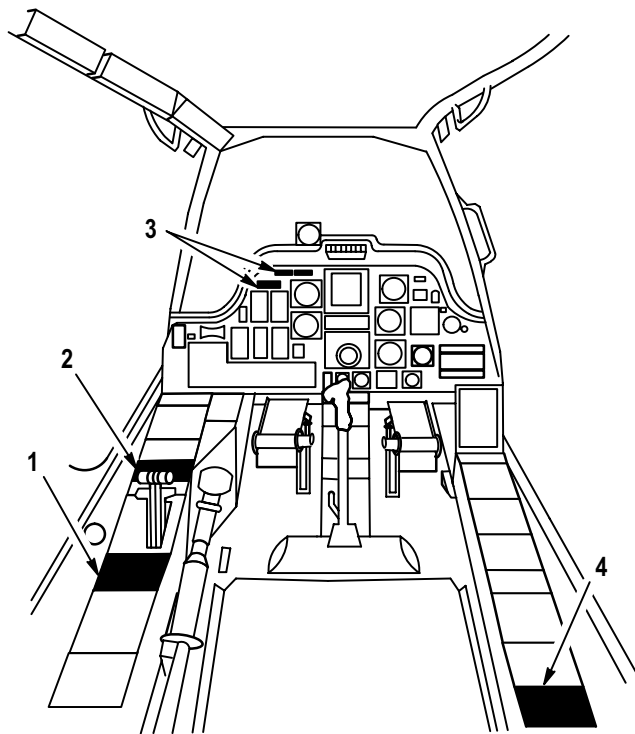

1. PILOT FUEL PANEL
2. PILOT ELEC PWR PANEL
3. PILOT FIRE EXTINGUISHER PANEL
4. PILOT APU FIRE TEST PANEL

M71-126A

**Figure 12-105. Pilot Station**

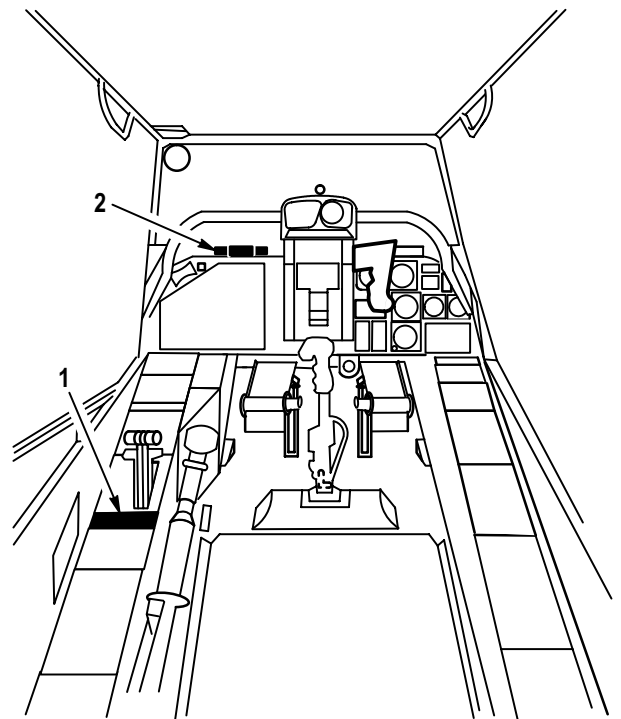

1. CPG FUEL PANEL
2. CPG GLARESHIELD FIRE EXTINGUISHER PANEL

M71-127

**Figure 12-106. CPG Station**

1. On pilot **ELEC PWR** panel (fig. 12-107), set **BATT/EXT PWR** switch to **EXT PWR**.

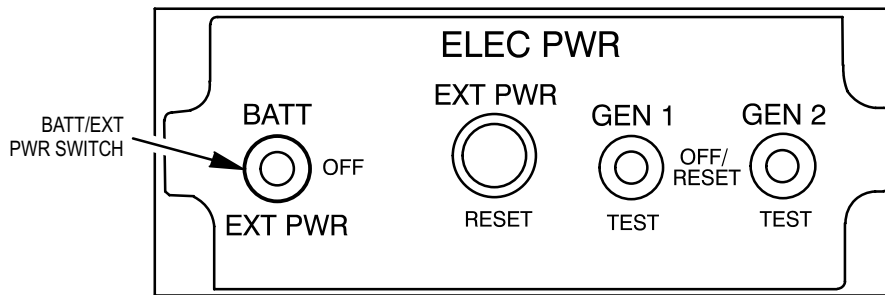

M71-128

**Figure 12-107. Pilot ELEC PWR Panel**

2. On pilot center circuit breaker panel (fig. 12-108), check that the following circuit breakers are closed:

<u>Circuit Breaker</u>	<u>Circuit Breaker</u>
<b>LT CAUT</b>	<b>FUEL APU</b>
<b>FIRE EXTGH PLT</b>	<b>ENG LVR</b>
<b>FIRE EXTGH CPG</b>	<b>FUEL XFEED</b>
<b>FIRE EXTGH APU</b>	<b>LT PRI</b>
<b>FUEL VLV ACTR</b>	

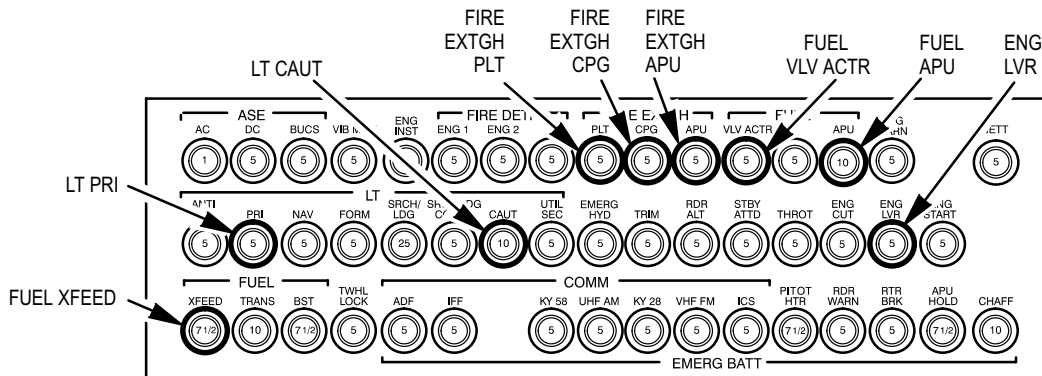

M71-129

**Figure 12-108. Pilot Center Circuit Breaker Panel**

3. On pilot **FUEL** panel (fig. 12-109), set following switches as indicated:

<u>Switch/Control</u>	<u>Position</u>
<b>ENG 1</b>	<b>ON</b>
<b>ENG 2</b>	<b>ON</b>
<b>CROSSFEED</b>	<b>NORM</b>
<b>BOOST</b>	<b>OFF</b>
<b>TRANS</b>	<b>OFF</b>
<b>EXT TK</b>	<b>OFF</b>

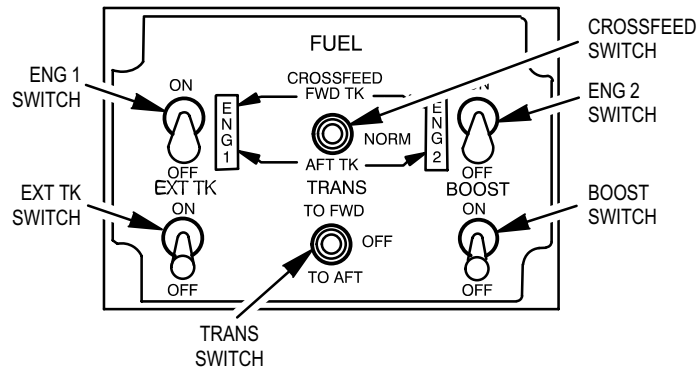

M71-130

Figure 12-109. Pilot FUEL Panel

4. On CPG FUEL panel (fig. 12-110), set **ORIDE** switch to **PLT**.

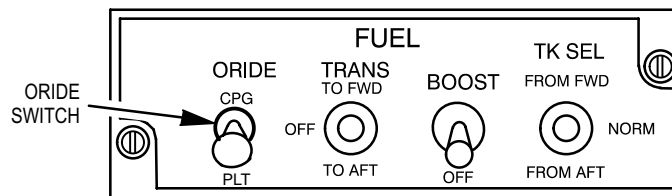

M71-131

Figure 12-110. CPG FUEL Panel

END OF TASK

**12-132. FIRE EXTINGUISHERS - POWER DOWN**

**12-132**

**Tools:**

<u>Nomenclature</u>	<u>Part Number</u>
Tool Kit, Electrical Repairer's	SC518099CLA06

**References:**

TM 55-1520-238-23

**Equipment Conditions:**

<u>Ref</u>	<u>Condition</u>
Paragraph 12-131	FIRE EXTINGUISHERS - POWER UP completed

**Personnel Required:**

68X Armament/Electrical Systems Repairer

**NOTE**

**Refer to pilot station (fig. 12-105) and CPG station (fig. 12-106) for cockpit configuration and equipment.**

1. On pilot **FUEL** control panel (fig. 12-109), set the following switches as indicated:

<u>Switch/Control</u>	<u>Position</u>
<b>ENG 1</b>	<b>OFF</b>
<b>ENG 2</b>	<b>OFF</b>

2. On pilot center circuit breaker panel (fig. 12-108), open the following circuit breakers:

<u>Circuit Breaker</u>	<u>Circuit Breaker</u>
<b>LT CAUT</b>	<b>FUEL APU</b>
<b>FIRE EXTGH PLT</b>	<b>ENG LVR</b>
<b>FIRE EXTGH CPG</b>	<b>FUEL XFEED</b>
<b>FIRE EXTGH APU</b>	<b>LT PRI</b>
<b>FUEL VLV ACTR</b>	

3. On pilot **ELEC PWR** panel (fig. 12-107), set **BATT/EXT PWR** switch to **OFF**.
4. Remove external power - electrical and pressurized air (TM 55-1520-238-23).

END OF TASK



**12-133. FIRE EXTINGUISHERS - MAINTENANCE OPERATIONAL CHECK**

12-133

**Tools:**

<u>Nomenclature</u>	<u>Part Number</u>
Tool Kit, Aircraft Mechanic's	SC518099CLA01
Tool Kit, Electrical Repairer's	SC518099CLA06
Multimeter, Digital	AN/PSM-45

**Equipment Conditions:**

<u>Ref</u>	<u>Condition</u>
TM 1-1520-238-23	Access provisions - L200 and R200 panels removed; T250L, T250R, T290L, T290R and L325 doors opened
	External power application - Pressurized air
	Fire extinguishing system inspection performed
TM 1-1520-238-T-7	FUEL SYSTEM - POWER UP completed
TM 1-1520-238-T-4	Maintenance headset connected

**Personnel Required:**

67R Attack Helicopter Repairer  
 68X Armament/Electrical Systems Repairer  
 67R3T Inspector

**References:**

TM 1-1520-238-T-4  
 TM 1-1520-238-T-7  
 TM 1-1520-238-23

**WARNING**

- Three electrically actuated explosive cartridges are located in each fire extinguisher container (bottle) triple valve. Before performing maintenance operational check, ground actuation studs as described in steps 1 and 3 to prevent accidental discharge of fire bottles.
- Fire extinguishing agent can burn eyes and skin or cause oxygen deficiency in a closed environment. Wear safety glasses whenever working around fire bottles. In case of accidental discharge of fire extinguishing agent, wash exposed skin with fresh water and ventilate if discharge occurs in a closed environment. If exposure occurs, seek medical aid immediately.
- Turn off power before detaching or attaching wires and connectors. High current 28 VDC or 115 VAC is present. Failure to do so could result in death or serious injury.

**NOTE**

- Refer to pilot station (fig. 12-105) and CPG station (fig. 12-106) for cockpit configuration and equipment.
- If referenced out of one paragraph or volume into another for additional troubleshooting, upon completion of the task, return to the maintenance operational check for the original paragraph or volume.

1. On primary fire bottle (fig. 12-111), attach shorting jumper wires between 3 actuation studs and adjacent ground studs (TM 1-1520-238-23).

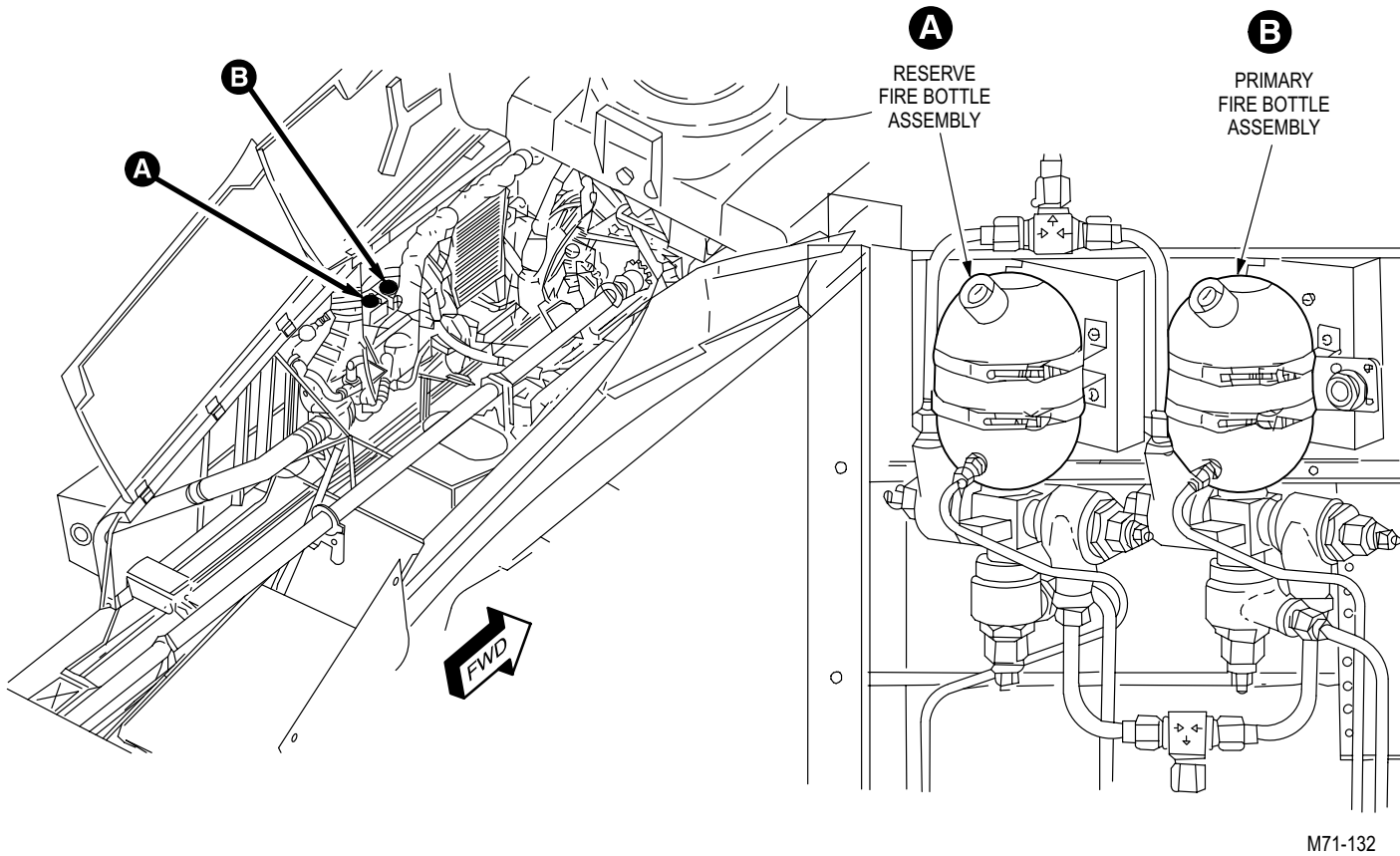

Figure 12-111. Fire Bottle Assemblies

2. Inspect (QA).
3. On reserve fire bottle (fig. 12-111), attach shorting jumper wires between 3 actuation studs and adjacent ground studs (TM 1-1520-238-23).
4. Inspect (QA).
5. Detach primary fire bottle plug P1 from jack J757.
6. Detach reserve fire bottle plug P1 from jack J758.
7. Perform FIRE EXTINGUISHERS - POWER UP (para 12-131).
8. Complete the maintenance operational check as follows:

Task	Result
a. On fuselage, check condition of fire bottle thermal discharge indicator (fig. 12-112).	If indicator shows signs of fire bottle discharge, replace indicator disk and recharge bottle(s) (TM 1-1520-238-23).

12-133. FIRE EXTINGUISHERS - MAINTENANCE OPERATIONAL CHECK (cont)

12-133

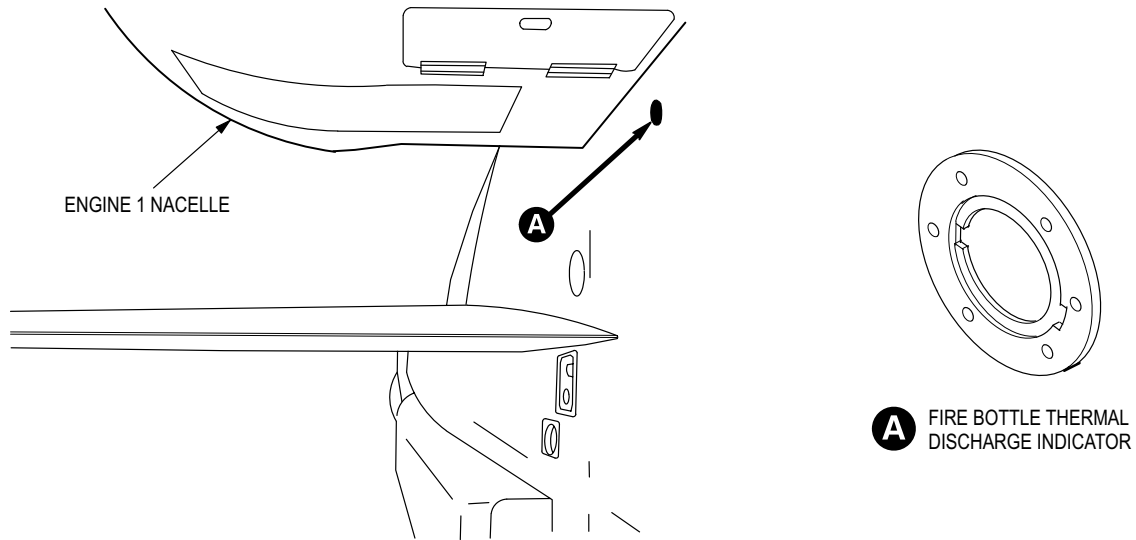

**A** FIRE BOTTLE THERMAL DISCHARGE INDICATOR

M71-133A

Figure 12-112. Fire Bottle Thermal Discharge Indicator

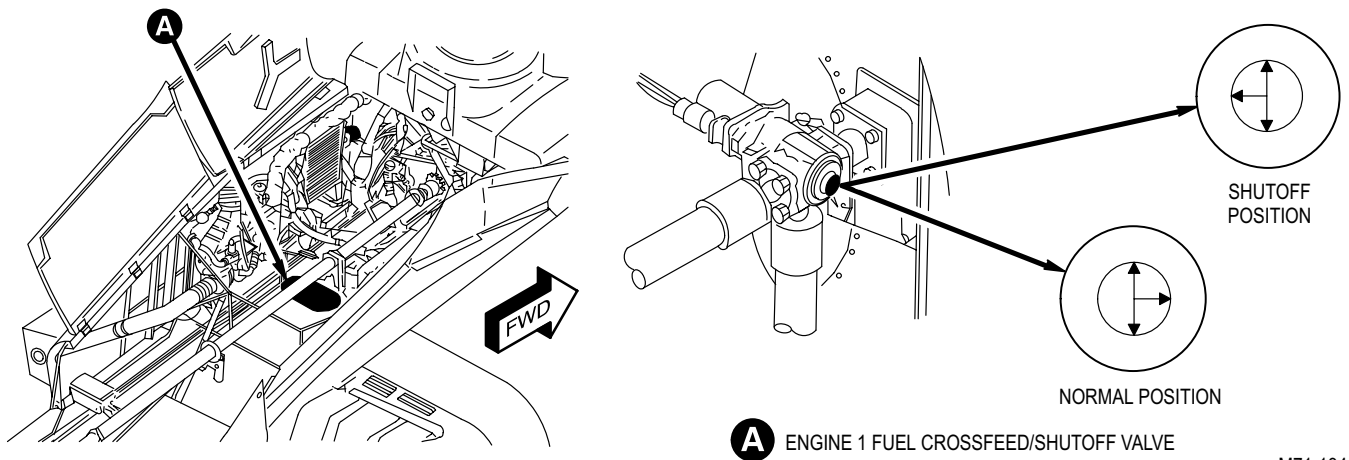

**A** ENGINE 1 FUEL CROSSFEED/SHUTOFF VALVE

M71-134

Figure 12-113. Engine 1 Fuel Crossfeed/Shutoff Valve

Task	Result
<p>b. On engine 1 (left) fuel crossfeed/shutoff valve (fig. 12-113), check that indicator is in normal (feed) position.</p>	<p>If indicator is not in normal position, refer to TM 1-1520-238-T-7 to troubleshoot fuel crossfeed/boost system.</p>
<p>c. On engine 1 louvers (fig. 12-114), check that louvers are in normal (open) position.</p>	<p>If louvers are not in normal position, refer to TM 1-1520-238-T-4 to troubleshoot power plants.</p>

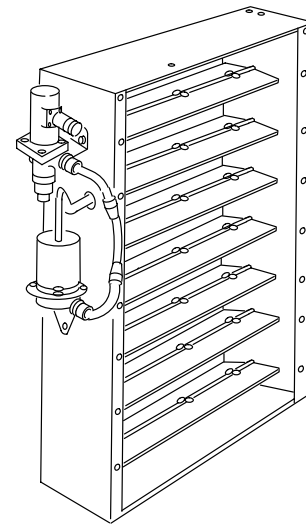
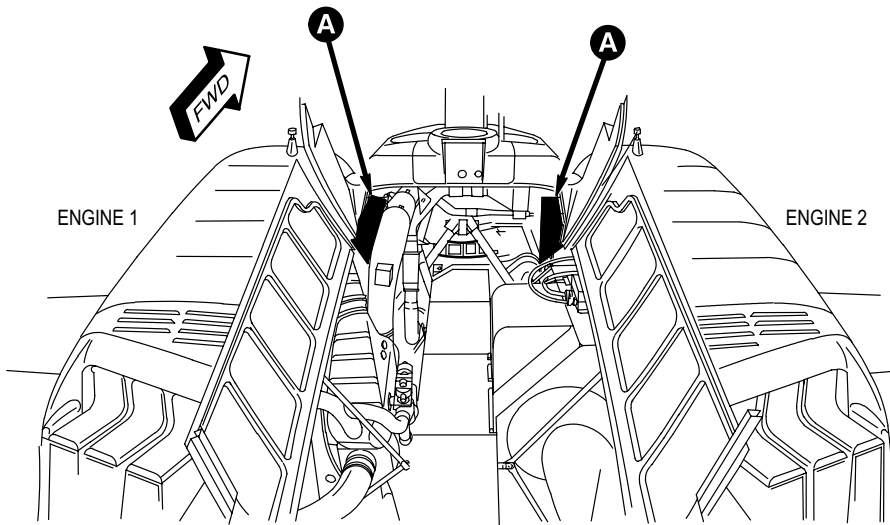

**A** ENGINE LOUVERS (TYPICAL)

M71-135

**Figure 12-114. Engine Louvers**

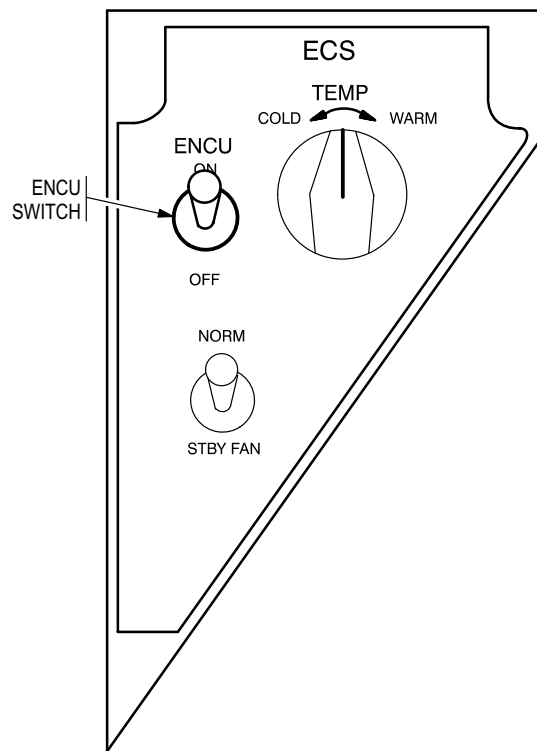

M71-318

**Figure 12-115. Pilot ECS Panel**

Task

Result

d. On pilot ECS panel (fig. 12-115), set **ENCU** switch to **ON**.

If ENCU does not operate, refer to Chapter 13 to troubleshoot ECS System.

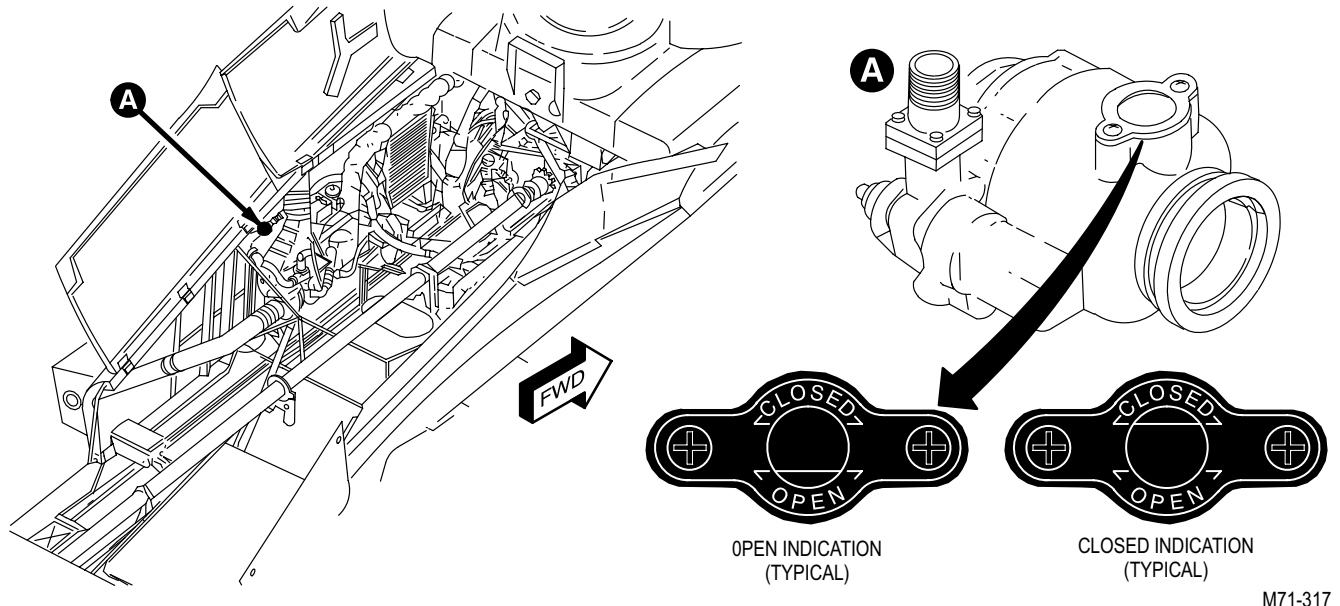

M71-317

Figure 12-116. ECS Shutoff Valve

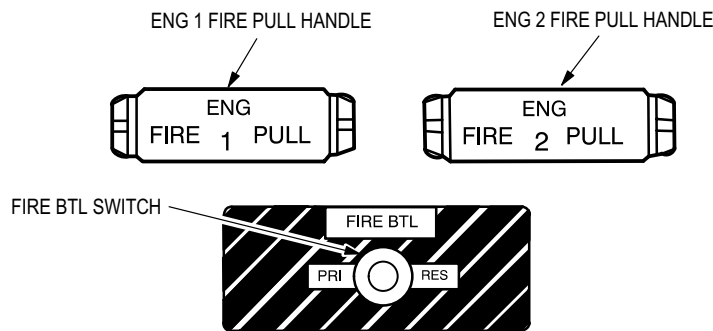

M71-136

Figure 12-117. Pilot Fire Extinguisher Panel

Task	Result
e. Check that ECS shutoff valve (fig. 12-116) is in <b>OPEN</b> position.	If ECS shutoff valve is not in <b>OPEN</b> position, refer to Chapter 13 to troubleshoot the ECS system.
f. On pilot fire extinguisher panel (fig. 12-117), pull <b>ENG 1 FIRE PULL</b> handle.	If handle does not stay in pulled position, replace handle switch (TM 1-1520-238-23).
g. On engine 1 fuel crossfeed/shutoff valve (fig. 12-113), check that indicator is now in shutoff position.	If valve does not shutoff, go to paragraph 12-135.
h. On engine 1 louvers (fig. 12-114), check that louvers are now in closed position.	If louvers do not close, go to paragraph 12-136.
i. Check that ECS shutoff valve (fig. 12-116) is in <b>CLOSED</b> position.	If ECS shutoff valve is not in <b>CLOSED</b> position, go to paragraph 12-140A.

## 12-133. FIRE EXTINGUISHERS - MAINTENANCE OPERATIONAL CHECK (cont)

12-133

Task	Result
j. With pilot fire extinguisher panel (fig. 12-117) <b>FIRE BTL</b> switch at center position, check for 0 VDC at J757-2 and J758-2.	If voltage is present, replace pilot <b>ENG 1 FIRE PULL</b> handle switch (TM 1-1520-238-23).
k. Hold pilot <b>FIRE BTL</b> switch in <b>PRI</b> position. Check for 28 VDC at J757-2.	If <b>FIRE EXTGH PLT</b> circuit breaker does not stay closed, go to paragraph 12-154.
	If primary fire bottle engine 1 cartridge actuator voltage is not present, go to paragraph 12-137.
l. Hold pilot <b>FIRE BTL</b> switch in <b>RES</b> position. Check for 28 VDC at J758-2.	If reserve fire bottle engine 1 cartridge actuator voltage is not present, go to paragraph 12-138.
m. Release pilot <b>FIRE BTL</b> switch and push pilot <b>ENG 1 FIRE PULL</b> handle.	
n. On engine 1 fuel crossfeed/shutoff valve (fig. 12-113), check that indicator is now in normal position.	If indicator is not in normal position, refer to TM 1-1520-238-T-7 to troubleshoot fuel crossfeed/boost system.
o. On engine 1 louvers (fig. 12-114), check that louvers are now in normal position.	If louvers are not in normal position, refer to TM 1-1520-238-T-4 to troubleshoot louvers.
p. Check that ECS shutoff valve (fig. 12-116) is in <b>OPEN</b> position.	If ECS shutoff valve is not in <b>OPEN</b> position, refer to Chapter 13 to troubleshoot the ECS system.
q. On engine 2 (right) fuel crossfeed/shutoff valve (fig. 12-118), check that indicator is in normal position.	If indicator is not in normal position, refer to TM 1-1520-238-T-7 to troubleshoot fuel crossfeed/boost system.
r. On engine 2 louvers (fig. 12-114), check that louvers are in normal position.	If louvers are not in normal position, refer to TM 1-1520-238-T-4 to troubleshoot louvers.
s. On pilot fire extinguisher panel, pull <b>ENG 2 FIRE PULL</b> handle.	If handle does not stay in pulled position, replace handle switch (TM 1-1520-238-23).
t. On engine 2 fuel crossfeed/shutoff valve, check that indicator is now in shutoff position.	If valve does not shutoff, go to paragraph 12-139.
u. Check that engine 2 louvers (fig. 12-114) are now in closed position.	If engine 2 louvers do not in close, go to paragraph 12-140.
v. Check that ECS shutoff valve (fig. 12-116) is in <b>CLOSED</b> position.	If ECS shutoff valve is not in <b>CLOSED</b> position, go to paragraph 12-140A.
w. With pilot fire extinguisher panel <b>FIRE BTL</b> switch at off (center) position, check for 0 VDC at J757-3 and J758-3.	If voltage is present, replace pilot <b>ENG 2 FIRE PULL</b> handle switch (TM 1-1520-238-23).
x. Hold pilot <b>FIRE BTL</b> switch in <b>PRI</b> position. Check for 28 VDC at J757-3.	If primary fire bottle engine 2 cartridge actuator voltage is not present, go to paragraph 12-141.

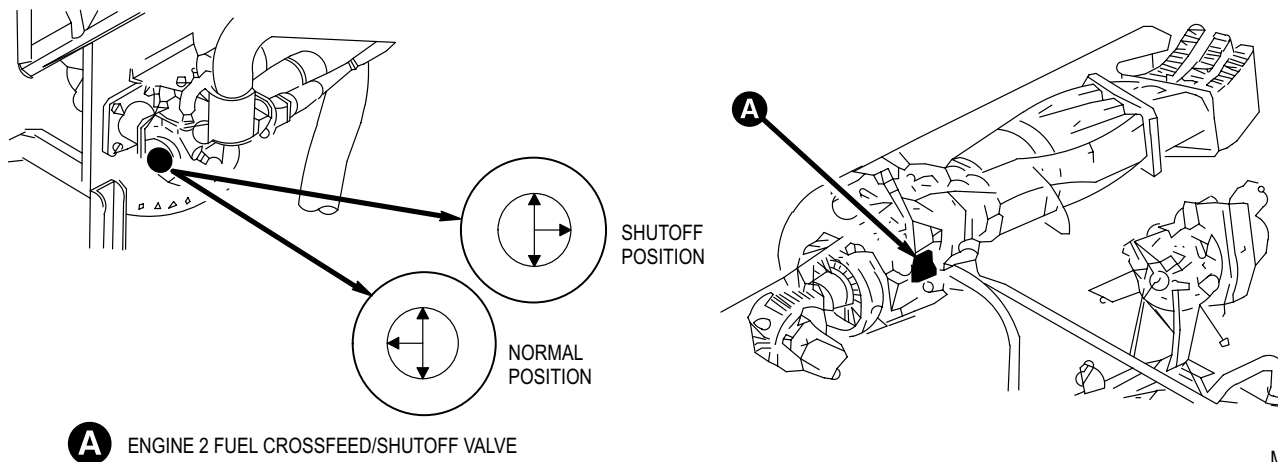

Figure 12-118. Engine 2 Fuel Crossfeed/Shutoff Valve

Task	Result
y. Hold pilot <b>FIRE BTL</b> switch (fig. 12-117) in <b>RES</b> position. Check for 28 VDC at J758-3.	If reserve fire bottle engine 2 cartridge voltage is not present, go to paragraph 12-142.
z. Release pilot <b>FIRE BTL</b> switch and push pilot <b>ENG 2 FIRE PULL</b> handle.	
aa. On engine 2 fuel crossfeed/shutoff valve (fig. 12-118), check that indicator is now in normal position.	If indicator is not in normal position, refer to TM 1-1520-238-T-7 to troubleshoot fuel crossfeed/boost system.
ab. Check that engine 2 louvers (fig. 12-114) are now in normal position.	If louvers are not in normal position, refer to TM 1-1520-238-T-4 to troubleshoot power plants.
ac. Check that ECS shutoff valve (fig. 12-116) is in <b>OPEN</b> position.	If ECS shutoff valve is not in <b>OPEN</b> position, refer to Chapter 13 to troubleshoot the ECS system.
ad. Touch or listen to APU fuel shutoff valve (fig. 12-119) to check that valve operates (opens) when <b>APU OFF/RUN/START</b> switch on pilot <b>APU</b> fire test panel (fig. 12-120) is set to <b>RUN</b> .	If valve does not operate, go to paragraph 15-12 to troubleshoot APU.
ae. Touch or listen to APU fuel shutoff valve to check that valve operates (closes) when <b>APU FIRE PULL</b> handle is pulled.	If valve does not operate, go to paragraph 15-12 to troubleshoot APU.
af. Pull <b>APU FIRE PULL</b> handle (fig. 12-117).	If handle does not stay in pulled position, replace pilot <b>APU</b> fire test panel (TM 1-1520-238-23).
ag. With <b>APU FIRE BTL</b> switch at OFF (center) position, check for 0 VDC at J757-4 and J758-4.	If voltage is present, replace pilot <b>APU</b> fire test panel (TM 1-1520-238-23).

## 12-133. FIRE EXTINGUISHERS - MAINTENANCE OPERATIONAL CHECK (cont)

12-133

Task	Result
ah. On pilot <b>APU</b> fire test panel (fig. 12-120), hold <b>APU FIRE BTL</b> switch in <b>PRI</b> position. Check for 28 VDC at J757-4.	If <b>FIRE EXTGH APU</b> circuit breaker does not stay closed, go to paragraph 12-155.  If primary fire bottle APU cartridge actuator voltage is not present, go to paragraph 12-143.
ai. Hold <b>APU FIRE BTL</b> switch in <b>RES</b> position. Check for 28 VDC at J758-4.	If reserve fire bottle APU cartridge actuator voltage is not present, go to paragraph 12-144.
aj. Release <b>APU FIRE BTL</b> switch. Touch or listen to APU fuel shutoff valve to check that valve operates (opens) when <b>APU FIRE PULL</b> handle is pushed.	If valve does not operate, go to paragraph 15-12 to troubleshoot APU.
ak. Return <b>APU OFF/RUN/START</b> switch to <b>OFF</b> .	
al. Check that <b>PRI DISCH</b> and <b>RES DISCH</b> indicators on pilot <b>APU</b> fire test panel are lighted.	If indicators do not light, replace lamps (TM 1-1520-238-23). If lamps is still not lighted, go to paragraph 12-145.
am. Attach jumper wire between J757-1 and J757-5.	If <b>PRI DISCH</b> indicator remains lighted, replace relay K1 in pilot <b>APU</b> fire test panel (TM 1-1520-238-23).
an. Attach jumper wire between J758-1 and J758-5.	If <b>RES DISCH</b> indicator remains lighted, replace relay K2 in <b>APU</b> fire test panel (TM 1-1520-238-23).
ao. Detach jumper wires from J757 and J758.	
ap. On CPG fire extinguisher panel (fig. 12-121), pull <b>ENG 1 FIRE PULL</b> handle.	If handle does not stay in pulled position, replace handle switch (TM 1-1520-238-23).
aq. On engine 1 fuel crossfeed/shutoff valve (fig. 12-113), check that indicator is now in shutoff position.	If valve does not shutoff, go to paragraph 12-146.
ar. Check that engine 1 louvers (fig. 12-114) are now in closed position.	If louvers do not close, go to paragraph 12-147.
as. Check that ECS shutoff valve (fig. 12-116) is in <b>CLOSED</b> position.	If ECS shutoff valve is not in <b>CLOSED</b> position, go to paragraph 12-140A.
at. With CPG fire extinguisher panel <b>FIRE BTL</b> switch at center position, check for 0 VDC at J757-2 and J758-2.	If voltage is present, replace CPG <b>ENG 1 FIRE PULL</b> handle switch (TM 1-1520-238-23).
au. On CPG fire extinguisher panel (fig. 12-121), hold CPG <b>FIRE BTL</b> switch in <b>PRI</b> position. Check for 28 VDC at J757-2.	If <b>FIRE EXTGH CPG</b> circuit breaker does not stay closed, go to paragraph 12-156.  If primary fire bottle engine 1 cartridge actuator voltage is not present, go to paragraph 12-148.



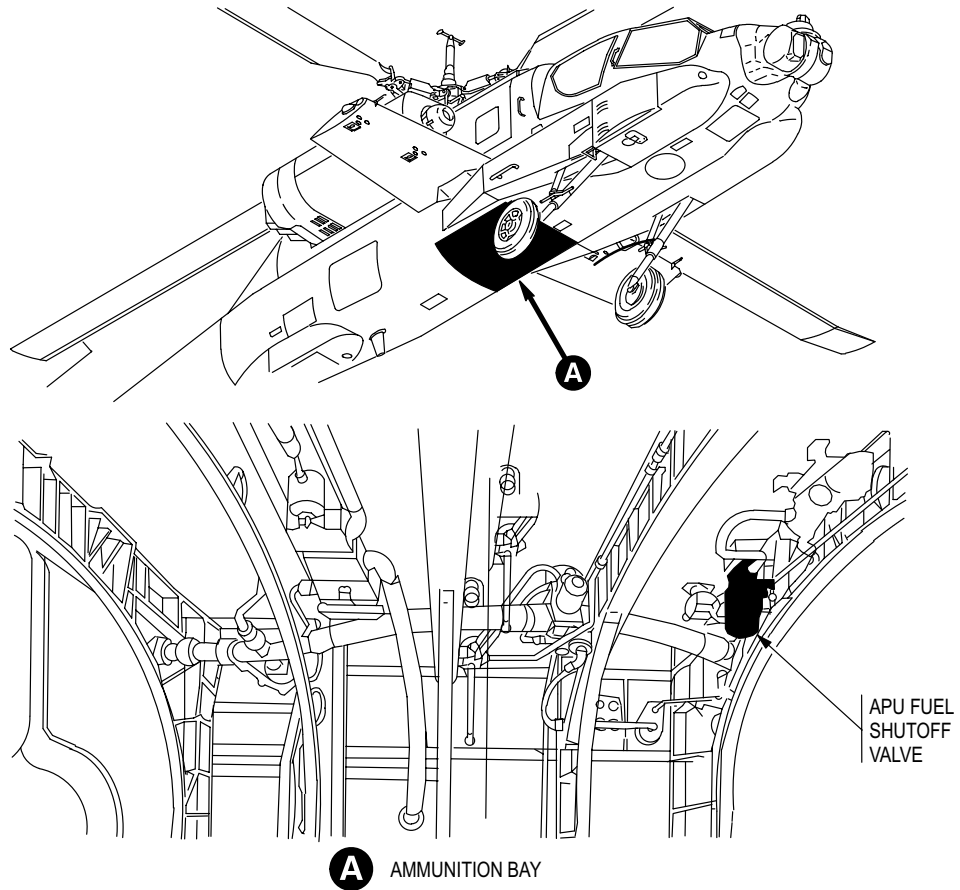

Figure 12-119. APU Fuel Shutoff Valve

M71-138

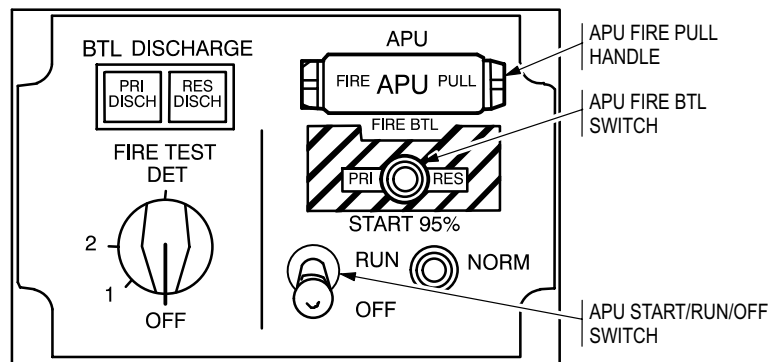

Figure 12-120. Pilot APU Fire Test Panel

M71-139A

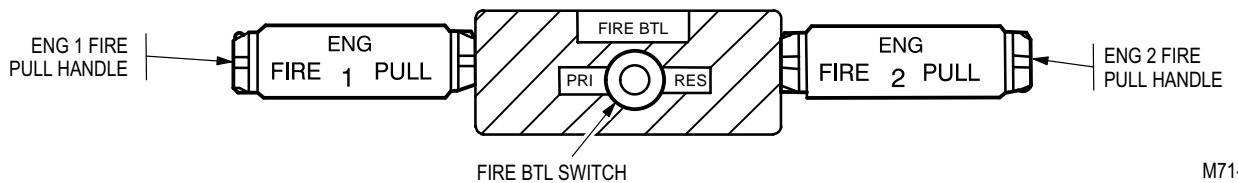

Figure 12-121. CPG Fire Extinguisher Panel

M71-140

## 12-133. FIRE EXTINGUISHERS - MAINTENANCE OPERATIONAL CHECK (cont)

12-133

Task	Result
av. Hold CPG <b>FIRE BTL</b> switch in <b>RES</b> position. Check for 28 VDC at J758-2.	If reserve fire bottle engine 1 cartridge actuator voltage is not present, go to paragraph 12-149.
aw. Release CPG <b>FIRE BTL</b> switch and push CPG <b>ENG 1 FIRE PULL</b> handle.	
ax. Check that ECS shutoff valve (fig. 12-116) is in <b>OPEN</b> position.	If ECS shutoff valve is not in <b>OPEN</b> position, refer to Chapter 13 to troubleshoot the ECS system.
ay. On CPG fire extinguisher panel, pull <b>ENG 2 FIRE PULL</b> handle.	If handle does not stay in pulled position, replace handle switch (TM 1-1520-238-23).
az. On engine 2 fuel crossfeed/shutoff valve (fig. 12-118), check that indicator is now in shutoff position.	If valve does not shutoff, go to paragraph 12-150.
ba. Check that engine 2 louvers (fig. 12-114) are now in closed position.	If louvers do not close, go to paragraph 12-151.
bb. Check that ECS shutoff valve (fig. 12-116) is in <b>CLOSED</b> position.	If ECS shutoff valve is not in <b>CLOSED</b> position, go to paragraph 12-140A.
bc. With CPG <b>FIRE BTL</b> switch (fig. 12-121) at off (center) position, check for 0 VDC at J757-3 and J758-3.	If voltage is present, replace CPG <b>ENG 2 FIRE PULL</b> handle switch (TM 1-1520-238-23).
bd. Hold CPG <b>FIRE BTL</b> switch in <b>PRI</b> position. Check for 28 VDC at J757-3.	If primary fire bottle engine 2 cartridge actuator voltage is not present, go to paragraph 12-152.
be. Hold CPG <b>FIRE BTL</b> switch in <b>RES</b> position. Check for 28 VDC at J758-3.	If reserve fire bottle engine 2 cartridge actuator voltage is not present, go to paragraph 12-153.
bf. Release CPG <b>FIRE BTL</b> switch and push <b>ENG 2 FIRE PULL</b> handle.	
bg. On pilot <b>ECS</b> panel (fig. 12-115), set <b>ENCU</b> switch to <b>OFF</b> .	

9. Perform FIRE EXTINGUISHERS - POWER DOWN (para 12-132).
10. Attach primary fire bottle plug P1 to J757.
11. Attach reserve fire bottle plug P1 to J758.
12. Detach shorting jumper wires between 6 actuation studs and adjacent ground studs on fire bottle triple valves.
13. Secure L200 and R200 access panels, and T250L, T250R, T290L, T290R and L325 access doors (TM 1-1520-238-23).
14. Disconnect maintenance headset (TM 1-1520-238-T-4).

END OF TASK



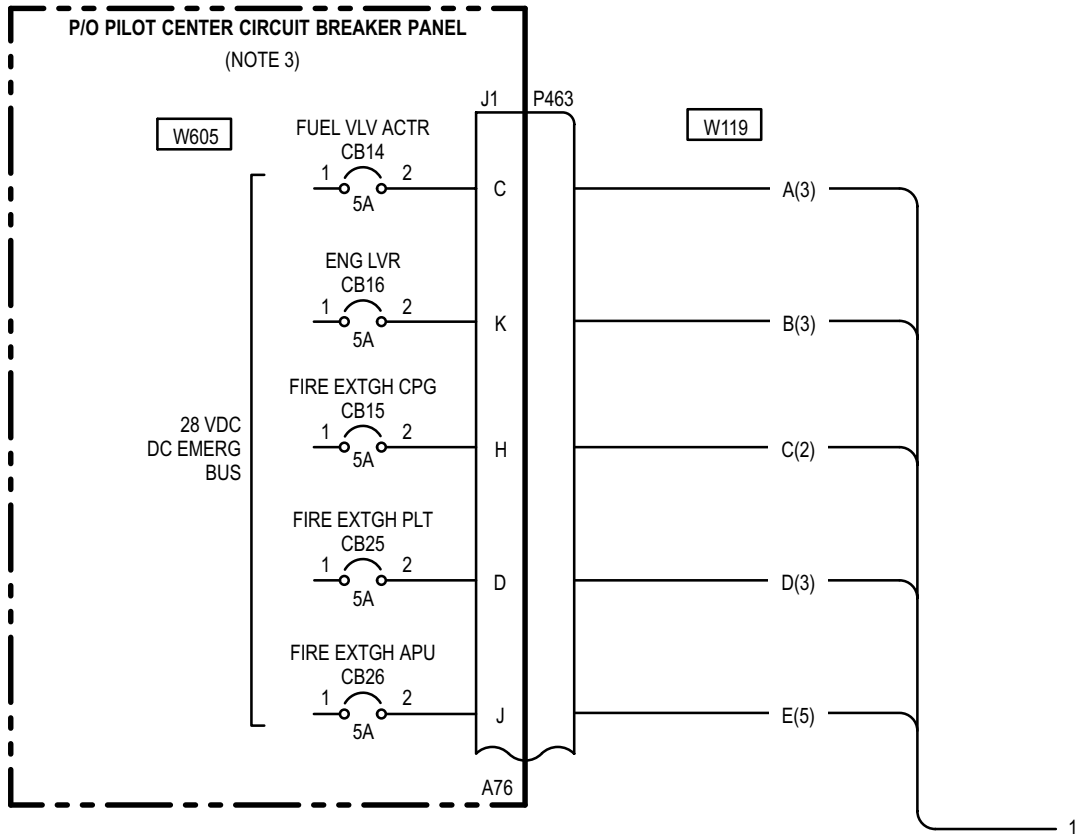

12-134. FIRE EXTINGUISHERS - WIRING INTERCONNECT DIAGRAM (cont)

12-134

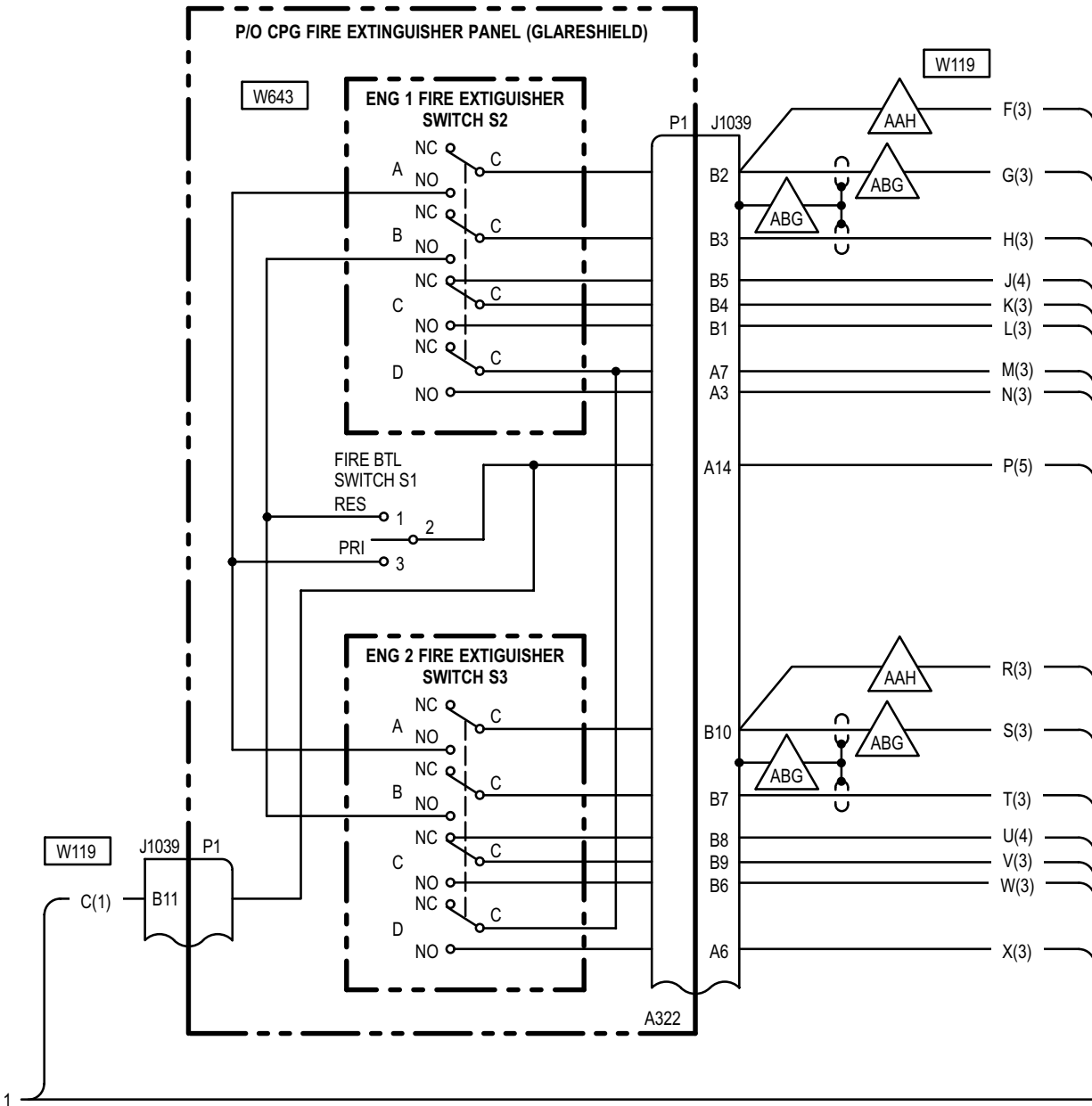

12-134. FIRE EXTINGUISHERS - WIRING INTERCONNECT DIAGRAM (cont)

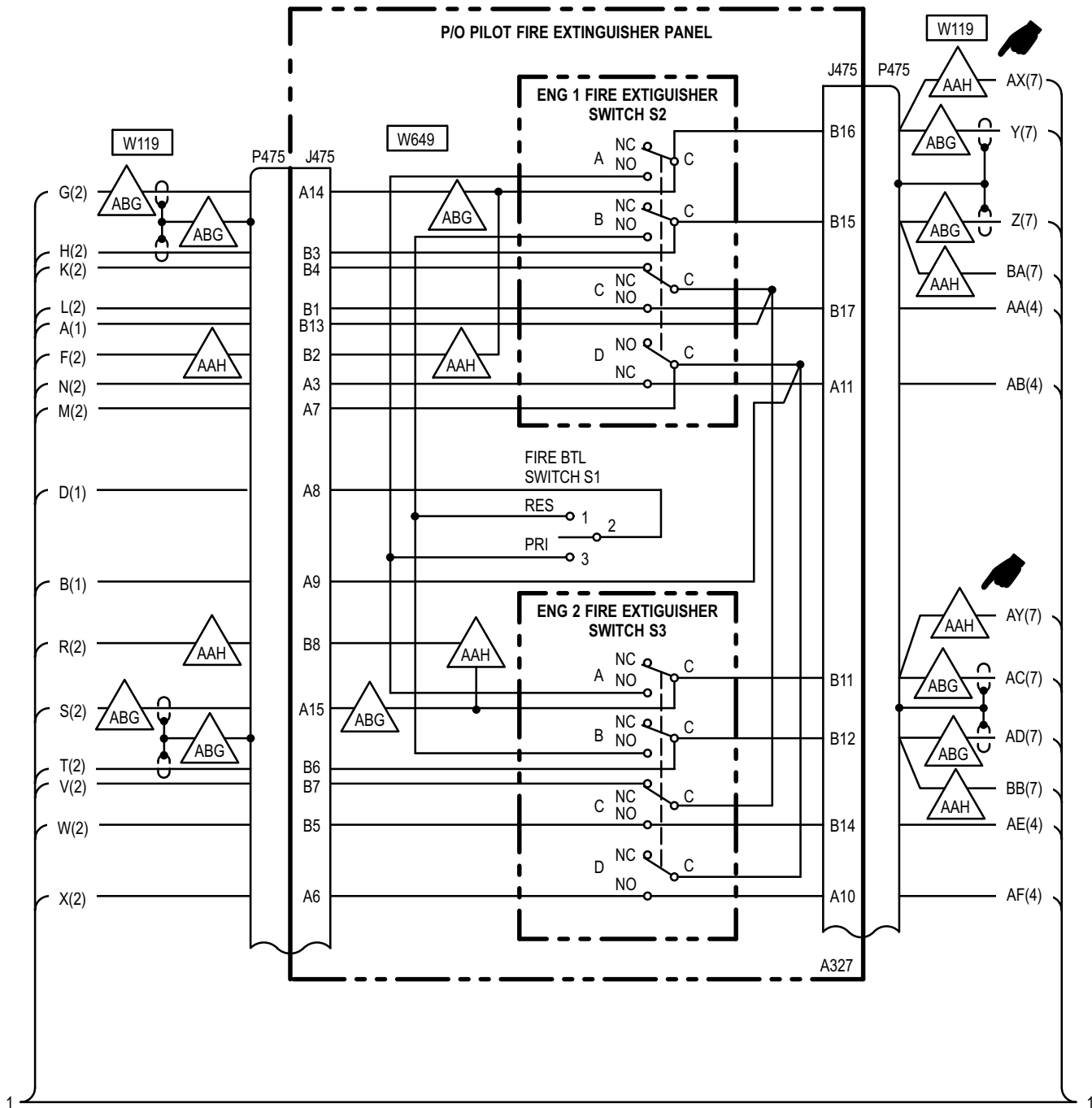

12-134. FIRE EXTINGUISHERS - WIRING INTERCONNECT DIAGRAM (cont)

12-134

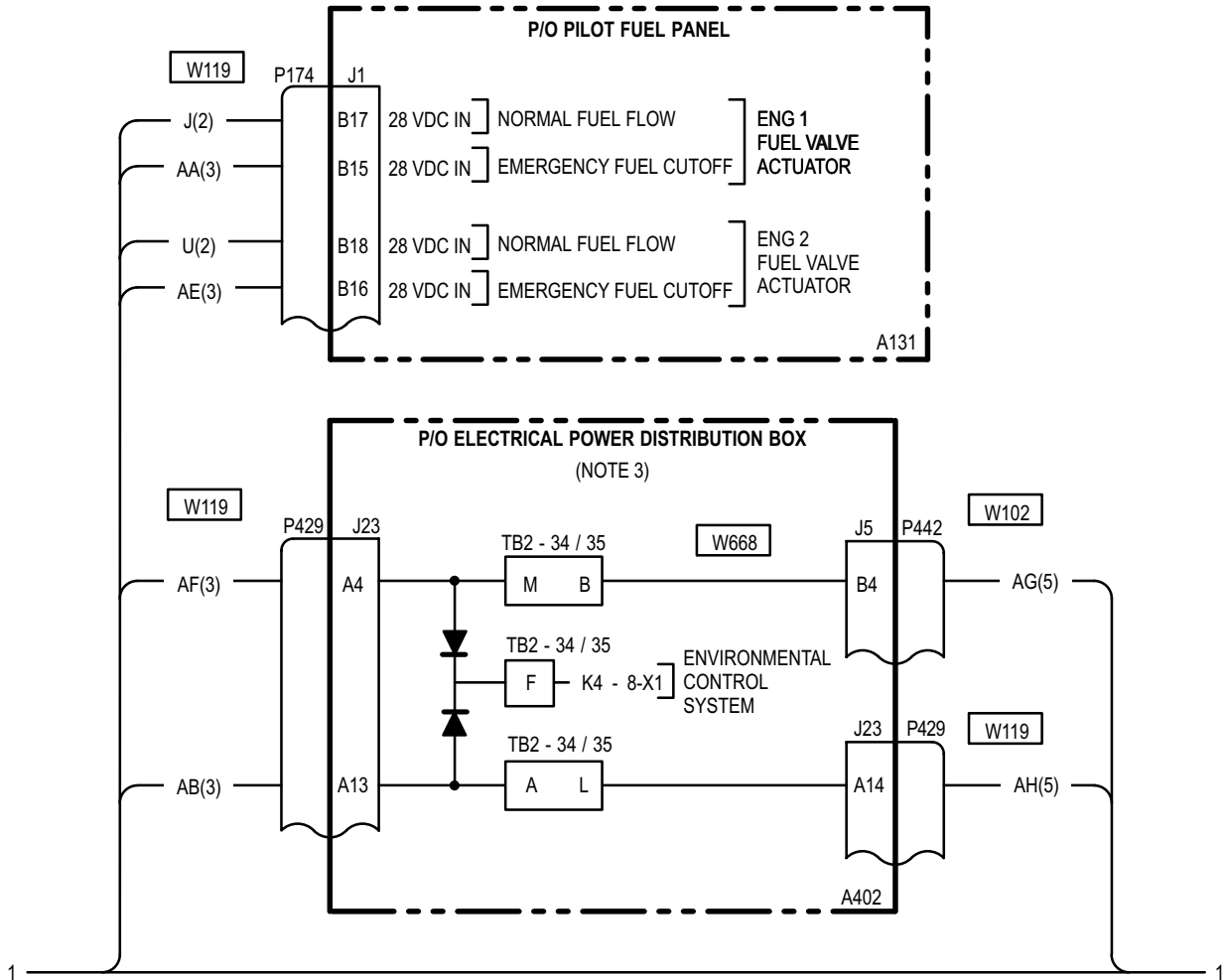

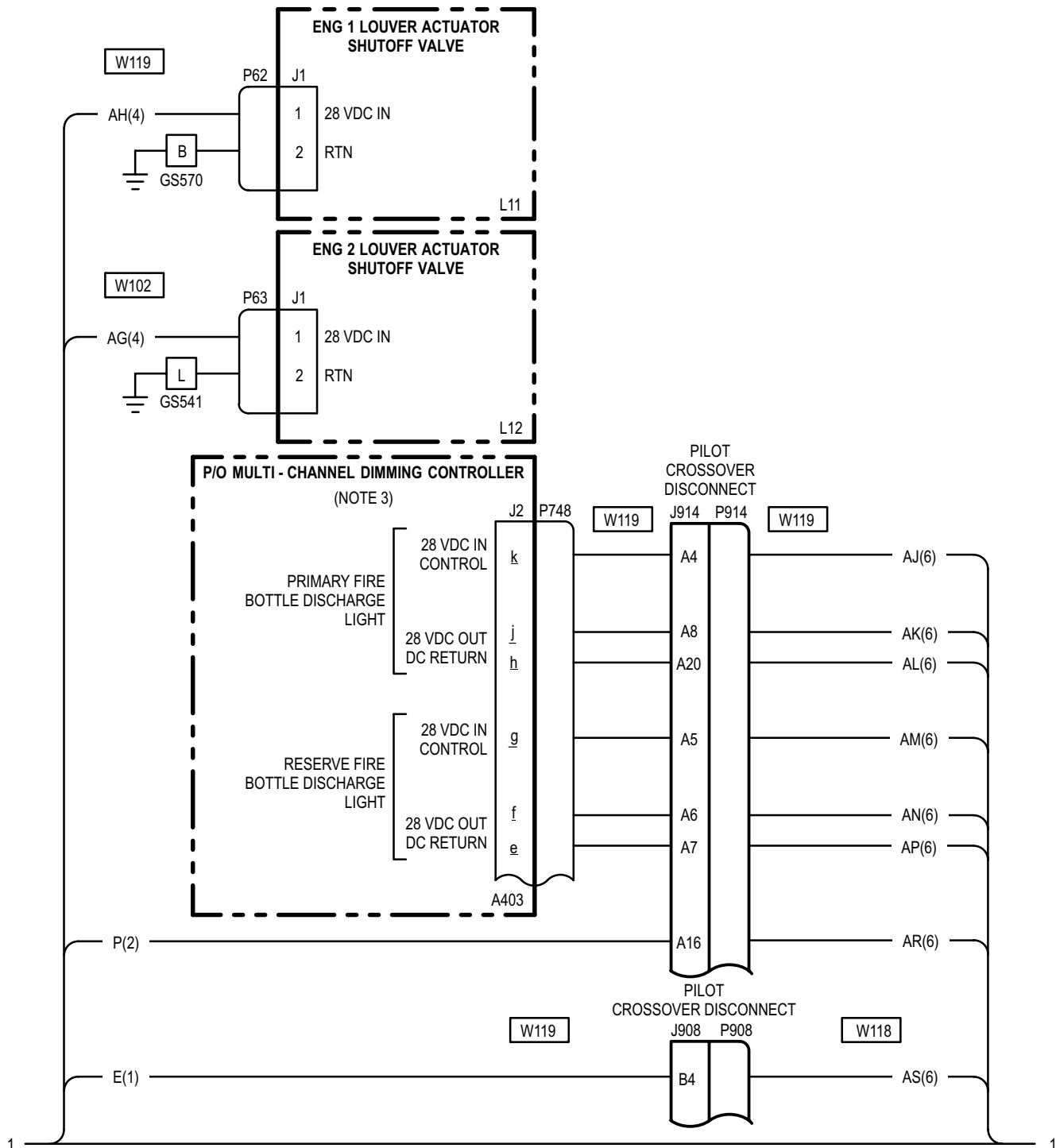



12-134. FIRE EXTINGUISHERS - WIRING INTERCONNECT DIAGRAM (cont)

12-134

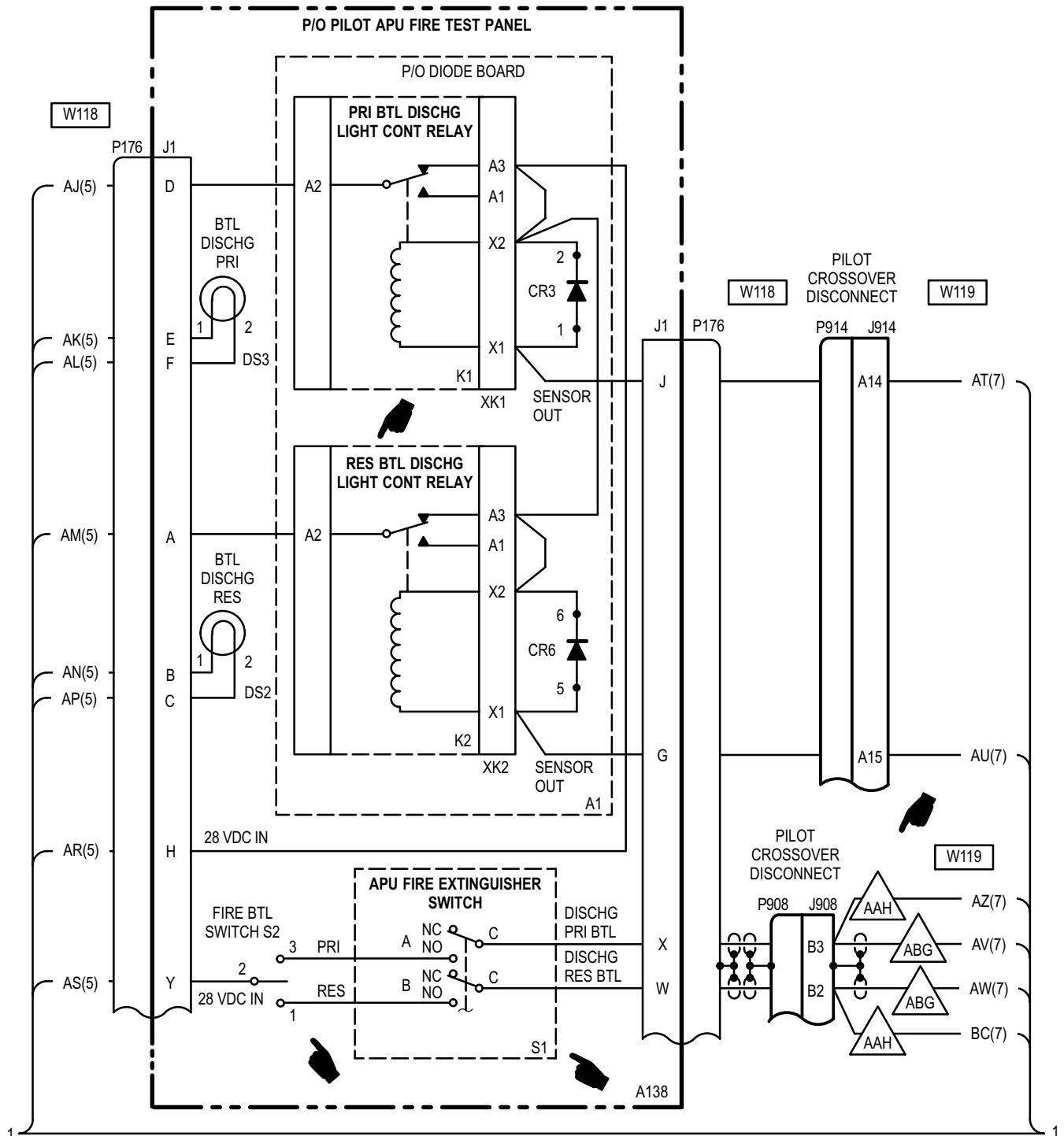

12-134. FIRE EXTINGUISHERS - WIRING INTERCONNECT DIAGRAM (cont)

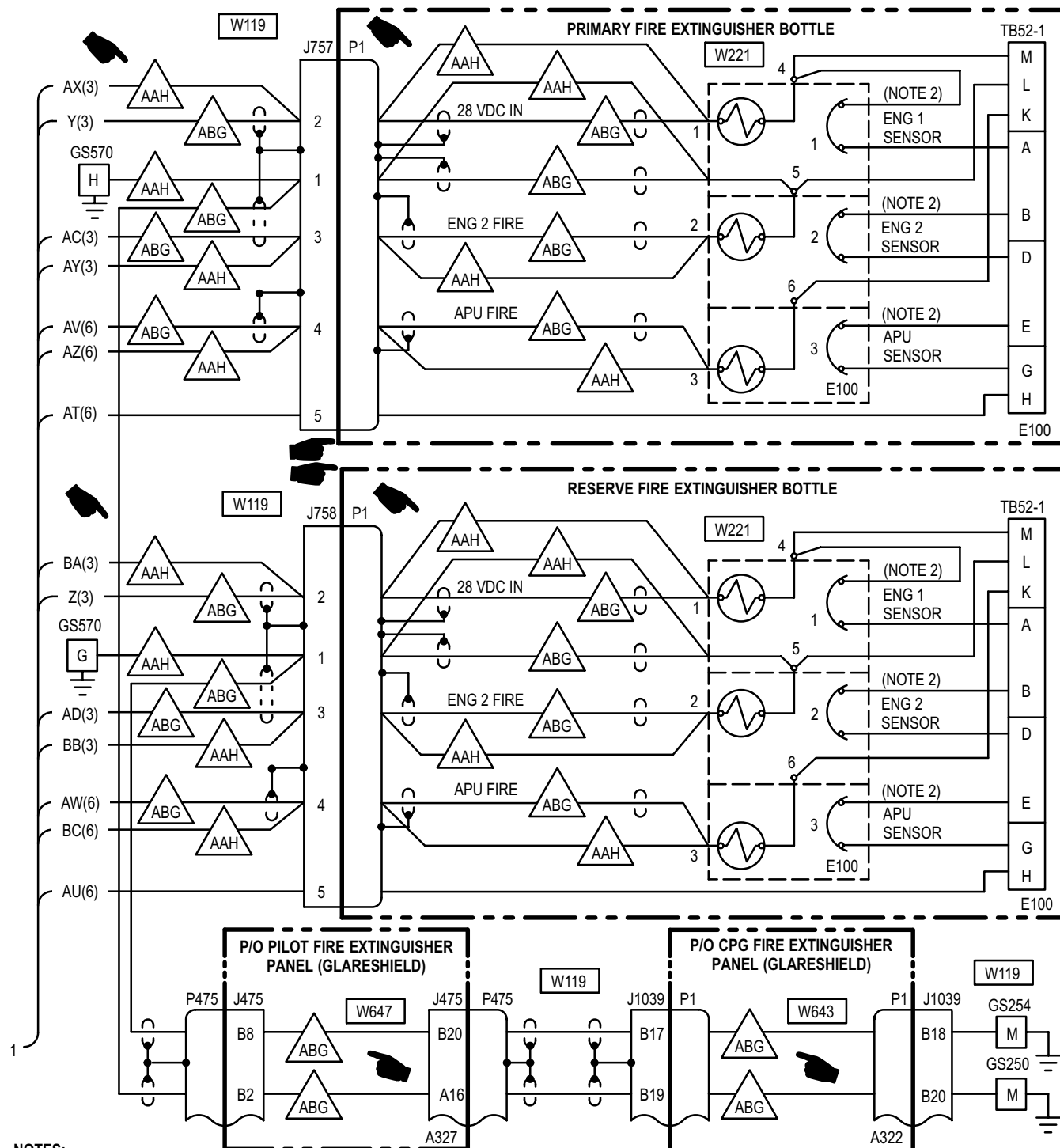

NOTES:  
 HIGHWAY USE: THE ALPHA CHARACTER IDENTIFIES A SPECIFIC LINE, AND THE NUMBER IN PARENTHESIS IDENTIFIES THE SHEET NUMBER WHERE THE SIGNAL TERMINATES.

1. ELECTRICALLY ACTUATED.
2. OPENS WHEN BOTTLE DISCHARGES.
3. ELECTRICAL SYSTEM (TM 1-1520-238-T-6).

M71-241-7C  
 SHEET 7 OF 7

**12-135. ENGINE 1 FUEL CROSSFEED/SHUTOFF VALVE - DOES NOT SHUTOFF WHEN PILOT ENG 1 FIRE PULL HANDLE IS PULLED**

12-135

**Tools:**

<u>Nomenclature</u>	<u>Part Number</u>
Tool Kit, Electrical Repairer's	SC518099CLA06
Multimeter, Digital	AN/PSM-45

**Personnel Required:**

68X Armament/Electrical Systems Repairer  
One person to assist

**References:**

TM 1-1520-238-T-6  
TM 1-1520-238-T-7  
TM 55-1520-238-23



**Turn off power before detaching or attaching wires and connectors. High current 28 VDC or 115 VAC is present. Failure to do so could result in death or serious injury.**

1. On pilot center circuit breaker panel, close **FUEL VLV ACTR** circuit breaker. On pilot extinguisher panel, pull **ENG 1 FIRE PULL** handle. Check for 28 VDC at P174-B15.

**Is voltage present?**

- |     |   |
|-----|---|
| YES | Refer to TM 1-1520-238-T-7 to troubleshoot fuel crossfeed/boost system. |
| NO  | Go to step 2.   |

2. Check for 28 VDC at P475-B13.

**Is voltage present?**

- |     |               |
|-----|---------------|
| YES | Go to step 4. |
| NO  | Go to step 3. |

3. On pilot circuit breaker panel, check for 28 VDC at (A76)J1-C.

**Is voltage present?**

- |     |  |
|-----|--|
| YES | Repair open wire between P463-C and P475-B13. Go to paragraph 12-133.                                    |
| NO  | Refer to TM 1-1520-238-T-6 to troubleshoot circuit protection system (dc emergency bus - pilot station). |

4. Check for open between (A327): J475-B13 and J475-B17.

**Does open exist?**

- |     |   |
|-----|---|
| YES | Replace pilot <b>ENG 1 FIRE PULL</b> handle switch (TM 55-1520-238-23). |
| NO  | Repair open wire between P475-B17 and P174-B15. Go to paragraph 12-133. |

END OF TASK

**12-136. ENGINE 1 LOUVERS - DO NOT CLOSE WHEN PILOT ENG 1 FIRE PULL HANDLE IS PULLED**

**Tools:**

<u>Nomenclature</u>	<u>Part Number</u>
Tool Kit, Electrical Repairer's	SC518099CLA06
Multimeter, Digital	AN/PSM-45

**Personnel Required:**

68X Armament/Electrical Systems Repairer  
One person to assist

**References:**

TM 1-1520-238-T-6  
TM 55-1520-238-23

**Equipment Conditions:**

<u>Ref</u>	<u>Condition</u>
TM 55-1520-238-23	Access provisions - L325, T250L, T250R, T290L and T290R doors opened

**WARNING**

**Turn off power before detaching or attaching wires and connectors. High current 28 VDC or 115 VAC is present. Failure to do so could result in death or serious injury.**

1. On pilot center circuit breaker panel, close **ENG LVR** circuit breaker. On pilot extinguisher panel, pull **ENG 1 FIRE PULL** handle. Check for 28 VDC at P62-1.

**Is voltage present?**

YES	Go to step 6.
NO	Go to step 2.

2. Check for 28 VDC at P429-A13.

**Is voltage present?**

YES	Repair open wire between: P429-A14 and P62-1. (A402): J23-A13 and J23-A14. Go to paragraph 12-133.
NO	Go to step 3.

3. Check for 28 VDC at (A327)P475-A9.

**Is voltage present?**

YES	Go to step 5.
NO	Go to step 4.

4. On pilot circuit breaker panel, check for 28 VDC at (A76)J1-K.

**Is voltage present?**

YES	Repair open wire between P463-K and P475-A9. Go to paragraph 12-133.
NO	Refer to TM 1-1520-238-T-6 to troubleshoot circuit protection system (dc emergency bus - pilot station).

5. Check for open between (A327): J475-A9 and J475-A11.

**Does open exist?**

YES	Replace pilot <b>ENG 1 FIRE PULL</b> handle switch (TM 55-1520-238-23).
NO	Repair open wire between P475-A11 and P429-A13. Go to paragraph 12-133.

6. Check for open between P62-2 and ground.

**Does open exist?**

YES	Repair open wire. Go to paragraph 12-133.
NO	Replace engine 1 louver directional control shutoff valve (TM 55-1520-238-23).

END OF TASK

**12-137. PRIMARY FIRE BOTTLE ENGINE 1 CARTRIDGE ACTUATION VOLTAGE - IS NOT PRESENT WITH PILOT FIRE BTL SWITCH IN PRI POSITION**

12-137

**Tools:**

<u>Nomenclature</u>	<u>Part Number</u>
Tool Kit, Electrical Repairer's	SC518099CLA06
Multimeter, Digital	AN/PSM-45

**Personnel Required:**

68X Armament/Electrical Systems Repairer  
One person to assist

**References:**

TM 1-1520-238-T-6  
TM 55-1520-238-23



**Turn off power before detaching or attaching wires and connectors. High current 28 VDC or 115 VAC is present. Failure to do so could result in death or serious injury.**

1. Check for 28 VDC at (A76)J1-D.

**Is voltage present?**

YES	Go to step 2.
NO	Refer to TM 1-1520-238-T-6 to troubleshoot circuit protection system (dc emergency bus - pilot station).

2. Check for open between P463-D and (A327)S1-2.

**Does open exist?**

YES	Repair open wire. Go to paragraph 12-133.
NO	Go to step 3.

3. On pilot fire extinguisher panel, hold **FIRE BTL** switch in **PRI** position and **ENG 1 FIRE PULL** handle pulled, check for open between (A327): J475-A8 and J475-B16.

**Does open exist?**

YES	Go to step 4.
NO	Repair open wire between P475-B16 and J757-2. Go to paragraph 12-133.

4. With pilot **FIRE BTL** switch held at **PRI**, check for open between switch terminals 2 and 3.

**Does open exist?**

YES	Replace pilot <b>FIRE BTL</b> switch handle (TM 55-1520-238-23).
NO	Replace pilot <b>ENG 1 FIRE PULL</b> handle switch (TM 55-1520-238-23).

END OF TASK

**12-138. RESERVE FIRE BOTTLE ENGINE 1 CARTRIDGE ACTUATION VOLTAGE - IS NOT PRESENT WITH PILOT FIRE BTL SWITCH IN RES POSITION**

**12-138**

**Tools:**

<u>Nomenclature</u>	<u>Part Number</u>
Tool Kit, Electrical Repairer's	SC518099CLA06
Multimeter, Digital	AN/PSM-45

**Personnel Required:**

68X Armament/Electrical Systems Repairer  
One person to assist

**References:**

TM 55-1520-238-23

**Equipment Conditions:**

<u>Ref</u>	<u>Condition</u>
TM 55-1520-238-23	Non-transparent barrier removed

- With pilot **FIRE BTL** switch held in **RES** position, check for open between switch terminals 1 and 2.

**Does open exist?**

YES	Replace pilot <b>FIRE BTL</b> switch (TM 55-1520-238-23).
NO	Replace pilot <b>ENG 1 FIRE PULL</b> handle switch (TM 55-1520-238-23).

**WARNING**

**Turn off power before detaching or attaching wires and connectors. High current 28 VDC or 115 VAC is present. Failure to do so could result in death or serious injury.**

- On pilot extinguisher panel, hold **FIRE BTL** switch at **RES** and pull **ENG 1 FIRE PULL** handle. Check for open between (A327): J475-A8 and J475-B15.

**Does open exist?**

YES	Go to step 2.
NO	Repair open wire between P475-B15 and J758-2. Go to paragraph 12-133.

END OF TASK

**12-139. ENGINE 2 FUEL CROSSFEED/SHUTOFF VALVE - DOES NOT SHUTOFF  
WHEN PILOT ENG 2 FIRE PULL HANDLE IS PULLED**

12-139

**Tools:**

<u>Nomenclature</u>	<u>Part Number</u>
Tool Kit, Electrical Repairer's	SC518099CLA06
Multimeter, Digital	AN/PSM-45

**Personnel Required:**

68X Armament/Electrical Systems Repairer

**References:**

TM 55-1520-238-23

2. On CPG glareshield extinguisher panel, pull **ENG 2 FIRE PULL** handle. With (A322)P1 detached from J1039, check for open between (A322):

P1-B6 and P1-B9.

**Does open exist?**

YES      Replace CPG **ENG 2 FIRE PULL** handle switch (TM 55-1520-238-23).

NO      Repair open wire between: P475-B5 and J1039-B6, P475-B7 and J1039-B9. Go to paragraph 12-133.

**WARNING**

**Turn off power before detaching or attaching wires and connectors. High current 28 VDC or 115 VAC is present. Failure to do so could result in death or serious injury.**

1. On pilot extinguisher panel, push **ENG 2 FIRE PULL** handle, check for open between (A327): J475-B5 and J475-B14, J475-B7 and J475-B13.

**Does open exist?**

YES      Replace pilot **ENG 2 FIRE PULL** handle switch (TM 55-1520-238-23).

NO      Go to step 2.

END OF TASK

**12-140. ENGINE 2 LOUVERS - DO NOT CLOSE WHEN PILOT ENG 2 FIRE PULL HANDLE IS PULLED**

**Tools:**

<u>Nomenclature</u>	<u>Part Number</u>
Tool Kit, Electrical Repairer's	SC518099CLA06
Multimeter, Digital	AN/PSM-45

**Personnel Required:**

68X Armament/Electrical Systems Repairer  
One person to assist

**References:**

TM 55-1520-238-23

**Equipment Conditions:**

<u>Ref</u>	<u>Condition</u>
TM 55-1520-238-23	Access provisions - L325, T250L, T250R, T290L and T290R doors opened

**WARNING**

**Turn off power before detaching or attaching wires and connectors. High current 28 VDC or 115 VAC is present. Failure to do so could result in death or serious injury.**

1. On pilot circuit breaker panel, close **ENG LVR** circuit breaker. On pilot fire extinguisher panel, pull **ENG 2 FIRE PULL** handle, check for 28 VDC at P63-1.

**Is voltage present?**

- |     |               |
|-----|---------------|
| YES | Go to step 4. |
| NO  | Go to step 2. |

2. Check for 28 VDC at P429-A4.

**Is voltage present?**

- |     |  |
|-----|--|
| YES | Repair open wire between: P442-B4 and P63-1. (A402): J23-A4 and J5-B4. Go to paragraph 12-133. |
| NO  | Go to step 3.  |

3. Check for open between (A327):

**Does open exist?**

- |     |   |
|-----|---|
| YES | Replace pilot <b>ENG 2 FIRE PULL</b> handle switch (TM 55-1520-238-23). |
| NO  | Repair open wire between: P475-A10 and P429-A4. Go to paragraph 12-133. |

4. Check for open between P63-2 and ground.

**Does open exist?**

- |     |  |
|-----|--|
| YES | Repair open wire. Go to paragraph 12-133.                                      |
| NO  | Replace engine 2 louver directional control shutoff valve (TM 55-1520-238-23). |

END OF TASK



**12-140A. ECS SHUTOFF VALVE DOES NOT CLOSE WHEN ENG 1 OR ENG 2  
FIRE PULL HANDLE IS PULLED**

**12-140A**

**Tools:**

<u>Nomenclature</u>	<u>Part Number</u>
Tool Kit, Electrical Repairer's	SC518099CLA06
Multimeter, Digital	AN/PSM-45

**Personnel Required:**

68X Armament/Electrical Systems Repairer  
One person to assist

**References:**

TM 1-1520-238-23

**Equipment Conditions:**

<u>Ref</u>	<u>Condition</u>
TM 1-1520-238-23	Access provisions - L325, T250L, T250R, T290L and T290R doors opened

3. Check for 28 VDC at TB2-34/35-F.

**Is voltage present?**

YES	Go to step 4.
NO	Replace both diodes connected to TB2-34/35-F (F to A/L and F to M/B, (TM 1-1520-238-23).

4. Check for open from K4/8-X2 to ground.

**Does open exist?**

YES	Repair open. Go to paragraph 12-133.
NO	Replace ENCU relay K4/8 (TM 1-1520-238-23).

**WARNING**

**Turn off power before detaching or attaching wires and connectors. High current 28 VDC or 115 VAC is present. Failure to do so could result in death or serious injury.**

1. Pull **ENG 1 FIRE PULL** handle. Check for 28VDC at P286-1.

**Is voltage present?**

YES	Go to step 2.
NO	Replace ENCU shutoff valve (TM 1-1520-238-23).

2. Pull **ENG 2 FIRE PULL** handle. Check for 28VDC at P286-1.

**Is voltage present?**

YES	Go to step 3.
NO	Replace diode between TB2-34/35-2A (or L) and F (TM 1-1520-238-23).

END OF TASK



**12-141. PRIMARY FIRE BOTTLE ENGINE 2 CARTRIDGE ACTUATION VOLTAGE - IS NOT PRESENT WITH PILOT FIRE BTL SWITCH IN PRI POSITION**

12-141

**Tools:**

<u>Nomenclature</u>	<u>Part Number</u>
Tool Kit, Electrical Repairer's	SC518099CLA06
Multimeter, Digital	AN/PSM-45

**Personnel Required:**

68X Armament/Electrical Systems Repairer  
One person to assist

**References:**

TM 55-1520-238-23

**Equipment Conditions:**

<u>Ref</u>	<u>Condition</u>
TM 55-1520-238-23	Non-transparent barrier removed

2. With pilot **FIRE BTL** switch held in **PRI** position, check for open between switch terminals 2 and 3.

**Does open exist?**

YES	Replace pilot <b>FIRE BTL</b> switch (TM 55-1520-238-23).
NO	Replace pilot <b>ENG 2 FIRE PULL</b> handle switch (TM 55-1520-238-23).

**WARNING**

**Turn off power before detaching or attaching wires and connectors. High current 28 VDC or 115 VAC is present. Failure to do so could result in death or serious injury.**

1. On pilot fire extinguisher panel, hold **FIRE BTL** switch in **PRI** position and pull **ENG 2 FIRE PULL** handle. Check for open between (A327): J475-A8 and J475-B11.

**Does open exist?**

YES	Go to step 2.
NO	Repair open wire between P475-B11 and J757-3. Go to paragraph 12-133.

END OF TASK

**12-142. RESERVE FIRE BOTTLE ENGINE 2 CARTRIDGE ACTUATION VOLTAGE - IS NOT PRESENT WITH PILOT FIRE BTL SWITCH IN RES POSITION**

12-142

**Tools:**

<u>Nomenclature</u>	<u>Part Number</u>
Tool Kit, Electrical Repairer's	SC518099CLA06
Multimeter, Digital	AN/PSM-45

**Personnel Required:**

68X Armament/Electrical Systems Repairer  
One person to assist

**References:**

TM 55-1520-238-23

**Equipment Conditions:**

<u>Ref</u>	<u>Condition</u>
TM 55-1520-238-23	Nontransparent barrier removed

2. With pilot **FIRE BTL** switch held in **RES** position, check for open between switch terminals 1 and 2.

**Does open exist?**

YES	Replace pilot <b>FIRE BTL</b> switch (TM 55-1520-238-23).
NO	Replace pilot <b>ENG 2 FIRE PULL</b> handle switch (TM 55-1520-238-23).

**WARNING**

Turn off power before detaching or attaching wires and connectors. High current 28 VDC or 115 VAC is present. Failure to do so could result in death or serious injury.

1. On pilot extinguisher panel, hold **FIRE BTL** switch in **RES** position and pull **ENG 2 FIRE PULL** handle. Check for open between (A327): J475-A8 and J475-B12.

**Does open exist?**

YES	Go to step 2.
NO	Repair open wire between P475-B12 and J758-3. Go to paragraph 12-133

END OF TASK

**12-143. PRIMARY FIRE BOTTLE APU CARTRIDGE ACTUATION VOLTAGE - IS NOT PRESENT WITH APU FIRE BTL SWITCH IN PRI POSITION**

12-143

**Tools:**

<u>Nomenclature</u>	<u>Part Number</u>
Tool Kit, Electrical Repairer's	SC518099CLA06
Multimeter, Digital	AN/PSM-45

**Personnel Required:**

68X Armament/Electrical Systems Repairer  
One person to assist

**References:**

TM 1-1520-238-T-6  
TM 55-1520-238-23



**Turn off power before detaching or attaching wires and connectors. High current 28 VDC or 115 VAC is present. Failure to do so could result in death or serious injury.**

1. Check for 28 VDC at P176-Y.  
**Is voltage present?**

YES      Go to step 3.  
NO        Go to step 2.

2. Check for open between:  
P463-J and J908-B4,  
P908-B4 and P176-Y.

**Does open exist?**

YES      Repair open wire.  
            Go to paragraph 12-133.  
  
NO        Refer to TM 1-1520-238-T-6 to  
            troubleshoot circuit protection  
            system (dc emergency bus -  
            pilot station).

3. On pilot **APU** fire test panel, hold **FIRE BTL** switch in **PRI** position and pull **APU FIRE PULL** handle. Check for open between (A138): J1-X and J1-Y.

**Does open exist?**

YES      Go to step 4.  
  
NO        Repair open wire between:  
            P176-X and P908-B3,  
            J908-B3 and J757-4.  
            Go to paragraph 12-133.

4. With **APU FIRE BTL** switch held in **PRI** position, check for open between switch terminals 2 and 3.

**Does open exist?**

YES      Replace **APU FIRE BTL** switch  
            (TM 55-1520-238-23).  
  
NO        Replace **APU FIRE PULL**  
            handle switch  
            (TM 55-1520-238-23).

END OF TASK

---

**12-144. RESERVE FIRE BOTTLE APU CARTRIDGE ACTUATION VOLTAGE -  
IS NOT PRESENT WITH APU FIRE BTL SWITCH IN RES POSITION**

---

12-144

**Tools:**

<u>Nomenclature</u>	<u>Part Number</u>
Tool Kit, Electrical Repairer's	SC518099CLA06
Multimeter, Digital	AN/PSM-45

**Personnel Required:**

68X Armament/Electrical Systems Repairer  
One person to assist

**References:**

TM 55-1520-238-23

---

**WARNING**

**Turn off power before detaching or attaching wires and connectors. High current 28 VDC or 115 VAC is present. Failure to do so could result in death or serious injury.**

1. On pilot **APU** fire test panel, hold **FIRE BTL** switch in **RES** position and pull **APU FIRE PULL** handle. Check for open between (A138): J1-W and J1-Y.

**Does open exist?**

- |     |  |
|-----|--|
| YES | Go to step 2.  |
| NO  | Repair open wire between:<br>P176-W and P908-B2,<br>J908-B2 and J758-4.<br>Go to paragraph 12-133. |

2. With APU **FIRE BTL** switch held in **RES** position, check for open between switch terminals 1 and 2.

**Does open exist?**

- |     |   |
|-----|---|
| YES | Replace APU <b>FIRE BTL</b> switch<br>(TM 55-1520-238-23).            |
| NO  | Replace <b>APU FIRE PULL</b><br>handle switch<br>(TM 55-1520-238-23). |

END OF TASK

12-145. PRI DISCH AND RES DISCH INDICATORS - DO NOT LIGHT

12-145

**Tools:**

Nomenclature	Part Number
Tool Kit, Electrical Repairer's	SC518099CLA06
Multimeter, Digital	AN/PSM-45

**Personnel Required:**

68X Armament/Electrical Systems Repairer  
One person to assist

**References:**

TM 1-1520-238-T-6  
TM 55-1520-238-23



**Turn off power before detaching or attaching wires and connectors. High current 28 VDC or 115 VAC is present. Failure to do so could result in death or serious injury.**

- On pilot master caution/warning panel, press **PRESS TO TEST** switch. On pilot **APU** fire test panel, check **PRI DISCH** and **RES DISCH** indicators.

**Do indicators light?**

YES	Go to step 2.
NO	Replace pilot <b>APU</b> fire test panel (TM 55-1520-238-23).

- On CPG circuit breaker panel 1, close **FIRE EXTGH CPG** circuit breaker (CB15), check for 28 VDC at P176-H.

**Is voltage present?**

YES	Go to step 4.
NO	Go to step 3.

- On pilot circuit breaker panel, check for 28 VDC at J1-H.

**Is voltage present?**

YES	Repair open wire between: P463-H and J1039-B11, J1039-A14 and J914-A16, P914-A16 and P176-H. (A322): P1-B11 and P1-A14. Go to paragraph 12-133.
NO	Refer to TM 1-1520-238-T-6 to troubleshoot circuit protection system (dc emergency bus - pilot station).

- Check for 28 VDC at P748-g and P748-k.

**Is voltage present?**

YES	Go to step 6.
NO	Go to step 5.

- Check for open between:

P176-A and P914-A5,  
P176-D and P914-A4,  
J914-A5 and P748-g,  
J914-A4 and P748-k.

**Does open exist?**

YES	Repair open wire. Go to paragraph 12-133.
NO	Replace pilot <b>APU</b> fire test panel (TM 55-1520-238-23).

- Check for short between:

J757-5 and J757-1,  
J758-5 and J758-1.

**Does short exist?**

YES	Repair shorted wire. Go to paragraph 12-133.
NO	Replace multi-channel dimming controller (TM 55-1520-238-23).

END OF TASK

**12-146. ENGINE 1 FUEL CROSSFEED/SHUTOFF VALVE - DOES NOT SHUTOFF WHEN CPG ENG 1 FIRE PULL HANDLE IS PULLED**

12-146

**Tools:**

<u>Nomenclature</u>	<u>Part Number</u>
Tool Kit, Electrical Repairer's	SC518099CLA06
Multimeter, Digital	AN/PSM-45

**Personnel Required:**

68X Armament/Electrical Systems Repairer

**References:**

TM 55-1520-238-23

**Equipment Conditions:**

<u>Ref</u>	<u>Condition</u>
TM 55-1520-238-23	Non-transparent barrier removed

2. Detach J1039. Pull CPG **ENG 1 FIRE PULL** handle. Check for open between (A322): P1-B1 and P1-B4.

**Does open exist?**

YES	Replace CPG <b>ENG 1 FIRE PULL</b> handle switch (TM 55-1520-238-23).
NO	Repair open wire between: P475-B1 and J1039-B1, P475-B4 and J1039-B4. Go to paragraph 12-133.

**WARNING**

**Turn off power before detaching or attaching wires and connectors. High current 28 VDC or 115 VAC is present. Failure to do so could result in death or serious injury.**

1. On pilot fire extinguisher panel, push **ENG 1 FIRE PULL** handle, check for open between (A327): J475-B4 and J475-B13.

**Does open exist?**

YES	Replace pilot <b>ENG 1 FIRE PULL</b> handle switch (TM 55-1520-238-23).
NO	Go to step 2.

END OF TASK



**12-147. ENGINE 1 LOUVERS - DO NOT CLOSE WHEN CPG ENG 1 FIRE PULL HANDLE IS PULLED**

12-147

**Tools:**

<u>Nomenclature</u>	<u>Part Number</u>
Tool Kit, Electrical Repairer's	SC518099CLA06
Multimeter, Digital	AN/PSM-45

**Personnel Required:**

68X Armament/Electrical Systems Repairer

**References:**

TM 55-1520-238-23

**Equipment Conditions:**

<u>Ref</u>	<u>Condition</u>
TM 55-1520-238-23	Non-transparent barrier removed

2. Detach J1039. Pull CPG **ENG 1 FIRE PULL** handle. Check for open between (A322): P1-A3 and P1-A7.

**Does open exist?**

- |     |   |
|-----|---|
| YES | Repair open wire between: (A327)P475-A3 and J1039-A3, (A327)P475-A7 and J1039-A7. Go to paragraph 12-133. |
| NO  | Replace CPG <b>ENG 1 FIRE PULL</b> handle switch (TM 55-1520-238-23).                                     |

**WARNING**

**Turn off power before detaching or attaching wires and connectors. High current 28 VDC or 115 VAC is present. Failure to do so could result in death or serious injury.**

1. On pilot fire extinguisher panel, push **ENG 1 FIRE PULL** handle, check for open between (A327): J475-A3 and J475-A11, J475-A7 and J475-A9.  
**Does open exist?**

- |     |   |
|-----|---|
| YES | Replace pilot <b>ENG 1 FIRE PULL</b> handle switch (TM 55-1520-238-23). |
| NO  | Go to step 2.   |

END OF TASK

**12-148. PRIMARY FIRE BOTTLE ENGINE 1 CARTRIDGE ACTUATION VOLTAGE - IS NOT PRESENT WITH CPG FIRE BTL SWITCH IN PRI POSITION**

**12-148**

**Tools:**

<u>Nomenclature</u>	<u>Part Number</u>
Tool Kit, Electrical Repairer's	SC518099CLA06
Multimeter, Digital	AN/PSM-45

**Personnel Required:**

68X Armament/Electrical Systems Repairer  
One person to assist

**References:**

TM 1-1520-238-T-6  
TM 55-1520-238-23

**Equipment Conditions:**

<u>Ref</u>	<u>Condition</u>
TM 55-1520-238-23	Nontransparent barrier removed



**Turn off power before detaching or attaching wires and connectors. High current 28 VDC or 115 VAC is present. Failure to do so could result in death or serious injury.**

1. On primary fire bottle, detach (E100)P1. On reserve fire bottle, detach (E100)P1. On CPG glareshield fire extinguisher panel, hold **FIRE BTL** switch in **PRI** position and pull CPG **ENG 1 FIRE PULL** handle. Check for open between: **(AAH)** P463-H and P475-B2. **(ABG)** P463-H and P475-A14.

**Does open exist?**

- YES Go to step 2.
- NO Go to step 5.

2. Detach (A322)P1. Hold CPG **FIRE BTL** switch in **PRI** position. Check for open between (A322): P1-B2 and P1-B11.

**Does open exist?**

- YES Go to step 3.
- NO Repair open wire between: **(AAH)** J1039-B2 and P475-B2, J1039-B11 and P463-H. **(ABG)** J1039-B2 and P475-A14, J1039-B11 and P463-H. Go to paragraph 12-133.

3. With CPG **FIRE BTL** switch held in **PRI** position, check for open between switch terminals 2 and 3.

**Does open exist?**

- YES Replace CPG **FIRE BTL** switch (TM 55-1520-238-23).
- NO Go to step 4.

4. Check for open between (A322): P1-B11 and S1-2, S1-3 and S2-A-NO, P1-B2 and S2-A-C.

**Does open exist?**

- YES Repair open wire. Go to paragraph 12-133.
- NO Replace CPG **ENG 1 FIRE PULL** handle switch (TM 55-1520-238-23).

---

**12-148. PRIMARY FIRE BOTTLE ENGINE 1 CARTRIDGE ACTUATION VOLTAGE -  
IS NOT PRESENT WITH CPG FIRE BTL SWITCH IN PRI POSITION (cont)**

---

12-148

5. Check for 28 VDC at (A76)J1-H.

**Is voltage present?**

- |     |   |
|-----|---|
| YES | Repair open wire between:<br><b>(AAH)</b> (A327):<br>J475-B2 and J475-B16.<br><b>(ABG)</b> P475-B16 and J757-2.<br>(A327):<br>J475-A14 and J475-B16.<br>Go to paragraph 12-133. |
| NO  | Refer to TM 1-1520-238-T-6 to<br>troubleshoot circuit protection<br>system (dc emergency bus -<br>pilot station).   |

END OF TASK

**12-149. RESERVE FIRE BOTTLE ENGINE 1 CARTRIDGE ACTUATION VOLTAGE - IS NOT PRESENT WITH CPG FIRE BTL SWITCH IN RES POSITION**

**Tools:**

<u>Nomenclature</u>	<u>Part Number</u>
Tool Kit, Electrical Repairer's	SC518099CLA06
Multimeter, Digital	AN/PSM-45

**Personnel Required:**

68X Armament/Electrical Systems Repairer  
One person to assist

**References:**

TM 55-1520-238-23

**Equipment Conditions:**

<u>Ref</u>	<u>Condition</u>
TM 55-1520-238-23	Non-transparent barrier removed

**WARNING**

**Turn off power before detaching or attaching wires and connectors. High current 28 VDC or 115 VAC is present. Failure to do so could result in death or serious injury.**

1. On CPG glareshield fire extinguisher panel, hold **FIRE BTL** switch in **RES** position, check for 28 VDC at P475-B3.

**Is voltage present?**

- |     |  |
|-----|--|
| YES | Repair open wire between: (A327)J475-B3 and (A327)J475-B15, (A327)P475-B15 and J758-2. Go to paragraph 12-133. |
| NO  | Go to step 2.  |

2. Hold CPG **FIRE BTL** switch in **RES** position. Check for open between (A322): P1-B3 and P1-B11.

**Does open exist?**

- |     |  |
|-----|--|
| YES | Go to step 3.  |
| NO  | Repair open wire between J1039-B3 and P475-B3. Attach J1039. Go to paragraph 12-133. |

3. With CPG **FIRE BTL** switch held in **RES** position, check for open between switch terminals 1 and 2.

**Does open exist?**

- |     |   |
|-----|---|
| YES | Replace CPG <b>FIRE BTL</b> switch (TM 55-1520-238-23). Attach J1039. |
| NO  | Go to step 4.   |

4. Check for open between (A322): P1-B11 and S1-2, S1-1 and S2-B-NO.

**Does open exist?**

- |     |   |
|-----|---|
| YES | Repair open wire. Go to paragraph 12-133.   |
| NO  | Replace CPG <b>ENG 1 FIRE PULL</b> handle switch (TM 55-1520-238-23). Attach J1039. |

END OF TASK

**12-150. ENGINE 2 FUEL CROSSFEED/SHUTOFF VALVE - DOES NOT SHUTOFF  
WHEN CPG ENG 2 FIRE PULL HANDLE IS PULLED**

12-150

**Tools:**

<u>Nomenclature</u>	<u>Part Number</u>
Tool Kit, Electrical Repairer's	SC518099CLA06
Multimeter, Digital	AN/PSM-45

**Personnel Required:**

68X Armament/Electrical Systems Repairer  
One person to assist

**References:**

TM 1-1520-238-T-6  
TM 55-1520-238-23

**Equipment Conditions:**

<u>Ref</u>	<u>Condition</u>
TM 55-1520-238-23	Access provisions - L200 panel removed Non-transparent barrier removed

2. Check for 28 VDC at P174-B16.

**Is voltage present?**

YES	Replace pilot <b>FUEL</b> panel (TM 55-1520-238-23).
NO	Go to step 3.

3. Check for 28 VDC at (A76)J1-C.

**Is voltage present?**

YES	Repair open wire between P475-B13 and P463-C. Go to paragraph 12-133.
NO	Refer to TM 1-1520-238-T-6 to troubleshoot circuit protection system (dc emergency bus - pilot station).

**WARNING**

**Turn off power before detaching or attaching wires and connectors. High current 28 VDC or 115 VAC is present. Failure to do so could result in death or serious injury.**

1. On pilot fire extinguisher panel, pull **ENG 2 FIRE PULL** handle, check for open between (A327): J475-B13 and J475-B14.

**Does open exist?**

YES	Replace pilot <b>ENG 2 FIRE PULL</b> handle switch (TM 55-1520-238-23).
NO	Go to step 2.

END OF TASK

**12-151. ENGINE 2 LOUVERS - DO NOT CLOSE WHEN CPG ENG 2 FIRE PULL HANDLE IS PULLED**

**Tools:**

<u>Nomenclature</u>	<u>Part Number</u>
Tool Kit, Electrical Repairer's	SC518099CLA06
Multimeter, Digital	AN/PSM-45

**Personnel Required:**

68X Armament/Electrical Systems Repairer  
One person to assist

**References:**

TM 1-1520-238-T-6  
TM 55-1520-238-23

**Equipment Conditions:**

<u>Ref</u>	<u>Condition</u>
TM 55-1520-238-23	Access provisions - L325, T250L, T250R, T290L, and T290R doors opened

**WARNING**

**Turn off power before detaching or attaching wires and connectors. High current 28 VDC or 115 VAC is present. Failure to do so could result in death or serious injury.**

1. Check for open between (A327):  
J475-A6 and J475-A10,  
J475-A7 and J475-A9.

**Does open exist?**

YES	Repair open wire. Go to paragraph 12-133.
NO	Go to step 2.

2. On CPG glareshield fire extinguisher panel, pull **ENG 2 FIRE PULL** handle, check for open between P475-A6 and P475-A7.

**Does open exist?**

YES	Go to step 5.
NO	Go to step 3.

3. Check for 28 VDC at (A76)J1-K.

**Is voltage present?**

YES	Go to step 4.
NO	Refer to TM 1-1520-238-T-6 to troubleshoot circuit protection system (dc emergency bus - pilot station).

4. Check for open between:

P475-A9 and P463-K,  
P475-A10 and P63-1,  
P63-2 and ground.

**Does open exist?**

YES	Repair open wire. Go to paragraph 12-133.
NO	Replace engine 2 louver actuator shutoff valve (TM 55-1520-238-23).

5. Push in CPG **FIRE EXT PULL** handle. Check for open between:

P475-A6 and (A322)S3-D-NO,  
P475-A7 and (A322)S3-D-C.

**Does open exist?**

YES	Repair open wire. Go to paragraph 12-133.
NO	Replace CPG <b>ENG 2 FIRE PULL</b> handle switch (TM 55-1520-238-23).

END OF TASK

**12-152. PRIMARY FIRE BOTTLE ENGINE 2 CARTRIDGE ACTUATION VOLTAGE - IS NOT PRESENT WITH CPG FIRE BTL SWITCH IN PRI POSITION**

12-152

**Tools:**

<u>Nomenclature</u>	<u>Part Number</u>
Tool Kit, Electrical Repairer's	SC518099CLA06
Multimeter, Digital	AN/PSM-45

**Personnel Required:**

68X Armament/Electrical Systems Repairer  
One person to assist

**References:**

TM 55-1520-238-23

**Equipment Conditions:**

<u>Ref</u>	<u>Condition</u>
TM 55-1520-238-23	Access provisions - L325, T250L, T250R, T290L, and T290R doors opened

**WARNING**

**Turn off power before detaching or attaching wires and connectors. High current 28 VDC or 115 VAC is present. Failure to do so could result in death or serious injury.**

1. On primary fire bottle, detach (E100)P1. On reserve fire bottle, detach (E100)P1. On CPG glareshield fire extinguisher panel, hold **FIRE BTL** switch in **PRI** position and pull CPG **ENG 2 FIRE PULL** handle, check for 28 VDC at:  
**(AAH)** P475-B8.  
**(ABG)** P475-A15.  
**Is voltage present?**  

YES	Go to step 5.
NO	Go to step 2.

2. With CPG **FIRE BTL** switch held in **PRI** position, check for open between (A322): P1-B10 and P1-B11.

**Does open exist?**

- |     |  |
|-----|--|
| YES | Go to step 3.  |
| NO  | Repair open wire between:<br><b>(AAH)</b> J1039-B10 and P475-B8.<br><b>(ABG)</b> J1039-B10 and P475-A15. Go to paragraph 12-133. |

3. With CPG **FIRE BTL** switch held in **PRI** position, check for open between switch terminals 2 and 3.

**Does open exist?**

- |     |   |
|-----|---|
| YES | Replace CPG <b>FIRE BTL</b> switch (TM 55-1520-238-23). |
| NO  | Go to step 4.   |

4. Check for open between CPG **ENG 2 FIRE PULL** handle switch terminals (A327): S3-A-NO and S3-A-C.

**Does open exist?**

- |     |  |
|-----|--|
| YES | Replace CPG <b>ENG 2 FIRE PULL</b> handle switch (TM 55-1520-238-23).  |
| NO  | Repair open wire between (A322):<br>P1-B11 and S1-2,<br>S1-3 and S3-A-NO,<br>S3-A-C and P1-B10.<br>Go to paragraph 12-133. |

---

**12-152. PRIMARY FIRE BOTTLE ENGINE 2 CARTRIDGE ACTUATION VOLTAGE -  
IS NOT PRESENT WITH CPG FIRE BTL SWITCH IN PRI POSITION (cont)**

---

12-152

5. Check for open between (A327):

**(AAH)** J475-B11 and J475-B8.**(ABG)** J475-B11 and J475-A15.**Does open exist?**

- |     |   |
|-----|---|
| YES | Repair open wire between:<br><b>(AAH)</b> J475-B11 and<br>J475-B8.<br><b>(ABG)</b> J475-B11 and<br>J475-A15.<br>Go to paragraph 12-133. |
| NO  | Repair open wire between<br>P475-B11 and J757-3.<br>Go to paragraph 12-133.   |

END OF TASK



**12-153. RESERVE FIRE BOTTLE ENGINE 2 CARTRIDGE ACTUATION VOLTAGE - IS NOT PRESENT WITH CPG FIRE BTL SWITCH IN RES POSITION**

12-153

**Tools:**

<u>Nomenclature</u>	<u>Part Number</u>
Tool Kit, Electrical Repairer's	SC518099CLA06
Multimeter, Digital	AN/PSM-45

**Personnel Required:**

68X Armament/Electrical Systems Repairer  
One person to assist

**References:**

TM 55-1520-238-23

**Equipment Conditions:**

<u>Ref</u>	<u>Condition</u>
TM 55-1520-238-23	Access provisions - L325, T250L, T250R, T290L, and T290 doors opened

**WARNING**

**Turn off power before detaching or attaching wires and connectors. High current 28 VDC or 115 VAC is present. Failure to do so could result in death or serious injury.**

1. On primary fire bottle, detach (E100)P1. On reserve fire bottle, detach (E100)P1. On CPG glareshield fire extinguisher panel, hold **FIRE BTL** switch in **RES** position and pull CPG **ENG 2 FIRE PULL** handle, check for 28 VDC at P475-B6.

**Is voltage present?**

YES Go to step 5.  
NO Go to step 2.

2. With CPG **FIRE BTL** switch held in **RES** position, check for open between (A322): P1-B7 and P1-B11.

**Does open exist?**

YES Go to step 3.  
NO Repair open wire between J1039-B7 and P475-B6. Go to paragraph 12-133.

3. With CPG **FIRE BTL** switch held in **RES** position, check for open between switch terminals 1 and 2.

**Does open exist?**

YES Replace CPG **FIRE BTL** switch (TM 55-1520-238-23).  
NO Go to step 4.

4. Check for open between CPG **ENG 2 FIRE PULL** handle switch terminals (A322): S3-B-NO and S3-B-C.

**Does open exist?**

YES Replace CPG **ENG 2 FIRE PULL** handle switch (TM 55-1520-238-23).  
NO Repair open wire between (A322): S1-1 and S3-B-NO, P1-B7 and S3-B-C. Go to paragraph 12-133.

5. Check for open wire between (A327): J475-B6 and J475-B12.

**Does open exist?**

YES Repair open wire between (A327): J475-B12 and S3-B-C, J475-B7 and S3-B-C. Go to paragraph 12-133.  
NO Repair open wire between P475-B12 and J758-3. Go to paragraph 12-133.

END OF TASK

12-154. FIRE EXTGH PLT CIRCUIT BREAKER (CB25) - DOES NOT STAY CLOSED

12-154

**Tools:**

<u>Nomenclature</u>	<u>Part Number</u>
Tool Kit, Electrical Repairer's	SC518099CLA06
Multimeter, Digital	AN/PSM-45

**Personnel Required:**

68X Armament/Electrical Systems Repairer

**References:**

TM 1-1520-238-T-6  
 TM 55-1520-238-23

**Equipment Conditions:**

<u>Ref</u>	<u>Condition</u>
TM 55-1520-238-23	Non-transparent barrier removed



**Turn off power before detaching or attaching wires and connectors. High current 28 VDC or 115 VAC is present. Failure to do so could result in death or serious injury.**

1. On pilot center circuit breaker panel, open **FIRE EXTGH PLT** circuit breaker (CB25). Detach P475. Check for short between P475-A8 and ground.

**Does short exist?**

- YES Go to step 2.
- NO Go to step 3.

2. Detach P463. Check for short between P463-D and ground.

**Does short exist?**

- YES Repair shorted wire between P475-A8 and P463-D. Go to paragraph 12-133.
- NO Refer to TM 1-1520-238-T-6 to troubleshoot circuit protection system (dc emergency bus - pilot station).

3. Detach (E100): 1, 2 and 3 primary and reserve terminals. Check for short between: P475-B16 and ground, P475-B15 and ground, P475-B11 and ground, P475-B12 and ground.

**Does short exist?**

- YES Repair shorted wire between: P475-B16 and J757-2, (E100)P1-2 and (E100)1 (PRI), P475-B15 and J758-2, (E100)P1-2 and (E100)1 (RES), P475-B11 and J757-3, (E100)P1-3 and (E100)2 (PRI), P475-B12 and J758-3, (E100)P1-3 and (E100)2 (RES). Go to paragraph 12-133.
- NO Go to step 4.

4. Check for short between: P475-B3 and ground, P475-B6 and ground. **(AAH)** P475-B2 and ground, P475-B8 and ground. **(ABG)** P475-A14 and ground, P475-A15 and ground.

**Does short exist?**

- YES Go to step 5.
- NO Go to step 9.

**12-154. FIRE EXTGH PLT CIRCUIT BREAKER (CB25) - DOES NOT STAY CLOSED (cont)****12-154**

5. Detach J1039 and check for short between:  
P475-B3 and ground,  
P475-B6 and ground.  
**(AAH)** P475-B2 and ground,  
P475-B8 and ground.  
**(ABG)** P475-A14 and ground,  
P475-A15 and ground.  
**Does short exist?**
- |     |   |
|-----|---|
| YES | Repair shorted wire between:<br>P475-B3 and J1039-B3,<br>P475-B6 and J1039-B7.<br><b>(AAH)</b> P475-B2 and J1039-B2,<br>P475-B8 and J1039-B10.<br><b>(ABG)</b> P475-A14 and J1039-B2,<br>P475-A15 and J1039-B10.<br>Go to paragraph 12-133. |
| NO  | Go to step 6.   |
6. Detach CPG **ENG 2 FIRE PULL** handle switch (A322): S3-A-C and S3-B-C. Check for short between (A322):  
P1-B7 and ground,  
P1-B10 and ground.  
**Does short exist?**
- |     |   |
|-----|---|
| YES | Repair shorted wire between (A322):<br>P1-B7 and S3-B-C,<br>P1-B10 and S3-A-C.<br>Go to paragraph 12-133. |
| NO  | Go to step 7.   |
7. Check for short between (A322):  
P1-B2 and ground,  
P1-B3 and ground.  
**Does short exist?**
- |     |   |
|-----|---|
| YES | Go to step 8.   |
| NO  | Replace CPG <b>ENG 2 FIRE PULL</b> handle switch (TM 55-1520-238-23). |
8. Detach CPG **ENG 1 FIRE PULL** handle switch (A322): S2-A-C and S2-B-C. Check for short between (A322):  
P1-B2 and ground,  
P1-B3 and ground.  
**Does short exist?**
- |     |  |
|-----|--|
| YES | Repair shorted wire between (A322):<br>P1-B2 and S2-A-C,<br>P1-B3 and S2-B-C.<br>Go to paragraph 12-133. |
| NO  | Replace CPG <b>ENG 1 FIRE PULL</b> handle switch S2 (TM 55-1520-238-23).                                 |
9. Check for short between J475-A8 and ground.  
**Does short exist?**
- |     |                |
|-----|----------------|
| YES | Go to step 10. |
| NO  | Go to step 11. |
10. Detach wire at pilot **FIRE BTL** switch S1-2. Check for short between (A327)J475-A8 and ground.  
**Does short exist?**
- |     |  |
|-----|--|
| YES | Repair shorted wire.<br>Go to paragraph 12-133.              |
| NO  | Replace pilot <b>FIRE BTL</b> switch S1 (TM 55-1520-238-23). |

**12-154. FIRE EXTGH PLT CIRCUIT BREAKER (CB25) - DOES NOT STAY CLOSED (cont)**

**12-154**

11. Check for short between (A327):  
 J475-B3 and ground,  
 J475-B6 and ground,  
 J475-B11 and ground,  
 J475-B12 and ground,  
 J475-B15 and ground,  
 J475-B16 and ground.  
**(ABG)** J475-A14 and ground,  
 J475-A15 and ground.  
**(AAH)** J475-B2 and ground,  
 J475-B8 and ground.  
**Does short exist?**
- |     |  |
|-----|--|
| YES | Repair shorted wire between (A327):<br>J475-B3 and S2-B-C,<br>J475-B6 and S3-B-C,<br>J475-B11 and S3-A-C,<br>J475-B12 and S3-B-C,<br>J475-B15 and S2-B-C,<br>J475-B16 and S2-A-C.<br><b>(ABG)</b> J475-A14 and S2-A-C,<br>J475-A15 and S3-A-C.<br><b>(AAH)</b> J475-B2 and S2-A-C,<br>J475-B8 and S3-A-C.<br>Go to paragraph 12-133. |
| NO  | Go to step 12.   |
12. Detach wire from pilot **FIRE BTL** switch (A327)S1-3. Check for short between wire (A327)S1-3 and ground.  
**Does short exist?**
- |     |                |
|-----|----------------|
| YES | Go to step 16. |
| NO  | Go to step 13. |
13. Detach wire from pilot **FIRE BTL** switch (A327)S1-1. Check for short between wire (A327)S1-1 and ground.  
**Does short exist?**
- |     |  |
|-----|--|
| YES | Go to step 14.   |
| NO  | Replace pilot <b>FIRE BTL</b> switch (A327)S1 (TM 55-1520-238-23). |
14. Detach pilot **ENG 1 FIRE PULL** handle switch (A327)S2-B-NO. Check for short between (A327)S1-1 and ground.  
**Does short exist?**
- |     |   |
|-----|---|
| YES | Go to step 15.  |
| NO  | Replace pilot <b>ENG 1 FIRE PULL</b> handle switch (TM 55-1520-238-23). |
15. Detach pilot **ENG 2 FIRE PULL** handle switch (A327)S3-B-NO. Check for short between (A327)S1-1 and ground.  
**Does short exist?**
- |     |  |
|-----|--|
| YES | Repair shorted wire between (A327):<br>S1-1 and S2-B-NO,<br>S1-1 and S3-B-NO.<br>Go to paragraph 12-133. |
| NO  | Replace pilot <b>ENG 2 FIRE PULL</b> handle switch (A327)S3 (TM 55-1520-238-23).                         |
16. Detach pilot **ENG 1 FIRE PULL** handle switch (A327)S2-A-NO. Check for short between (A327)S1-3 and ground.  
**Does short exist?**
- |     |  |
|-----|--|
| YES | Go to step 17.   |
| NO  | Replace pilot <b>ENG 1 FIRE PULL</b> handle switch S2 (TM 55-1520-238-23). |

---

**12-154. FIRE EXTGH PLT CIRCUIT BREAKER (CB25) - DOES NOT STAY CLOSED (cont)**

---

12-154

17. Detach pilot **ENG 2 FIRE PULL** handle switch (A327)S3-A-NO. Check for short between (A327)S1-3 and ground.

**Does short exist?**

- |     |  |
|-----|--|
| YES | Repair shorted wire between (A327):<br>S1-3 and S2-A-NO,<br>S1-3 and S3-A-NO.<br>Go to paragraph 12-133. |
| NO  | Replace pilot <b>ENG 2 FIRE PULL</b> handle switch (A327)S3 (TM 55-1520-238-23).                         |

END OF TASK

**12-155. FIRE EXTGH APU CIRCUIT BREAKER (CB26) - DOES NOT STAY CLOSED WITH FIRE BTL SWITCH SET TO PRI AND APU FIRE PULL HANDLE PULLED**

12-155

**Tools:**

<u>Nomenclature</u>	<u>Part Number</u>
Tool Kit, Electrical Repairer's	SC518099CLA06
Multimeter, Digital	AN/PSM-45

**Personnel Required:**

68X Armament/Electrical Systems Repairer  
One person to assist

**References:**

TM 1-1520-238-T-6  
TM 55-1520-238-23



**Turn off power before detaching or attaching wires and connectors. High current 28 VDC or 115 VAC is present. Failure to do so could result in death or serious injury.**

1. On pilot center circuit breaker panel, open **FIRE EXTGH APU** circuit breaker (CB26). Check for short between (A76)J1-J and ground.

**Does short exist?**

YES Refer to TM 1-1520-238-T-6 to troubleshoot circuit protection system (dc emergency bus - pilot station).

NO Go to step 2.

2. On pilot **APU** fire test panel, set **FIRE BTL** switch to **OFF**, check for short between P463-J and ground.

**Does short exist?**

YES Go to step 3.

NO Go to step 4.

3. Check for short between (A138)J1-Y and chassis ground.

**Does short exist?**

YES Replace pilot **APU** fire test panel (TM 55-1520-238-23).

NO Repair shorted wire between: P463-J and J908-B4, P908-B4 and P176-Y. Go to paragraph 12-133.

4. On pilot **APU** fire test panel, pull **APU FIRE PULL** handle with **FIRE BTL** switch set to **PRI**. Check for short between P463-J and ground.

**Does short exist?**

YES Go to step 5.

NO Go to step 6.

5. Check for short between P176-X and ground.

**Does short exist?**

YES Repair shorted wire between: P176-X and P908-B3, J908-B3 and J757-4. Go to paragraph 12-133.

NO Replace pilot **APU** fire test panel (TM 55-1520-238-23).

6. Check for short between P176-W and ground.

**Does short exist?**

YES Repair shorted wire between: P176-W and P908-B2, J908-B2 and J758-4. Go to paragraph 12-133.

NO Replace pilot **APU** fire test panel (TM 55-1520-238-23).

END OF TASK

**12-156. FIRE EXTGH CPG CIRCUIT BREAKER (CB15) - DOES NOT STAY CLOSED**

12-156

**Tools:**

<u>Nomenclature</u>	<u>Part Number</u>
Tool Kit, Electrical Repairer's	SC518099CLA06
Multimeter, Digital	AN/PSM-45

**Personnel Required:**

68X Armament/Electrical Systems Repairer  
One person to assist

**References:**

TM 1-1520-238-T-6  
TM 55-1520-238-23



**Turn off power before detaching or attaching wires and connectors. High current 28 VDC or 115 VAC is present. Failure to do so could result in death or serious injury.**

1. On pilot center circuit breaker panel, open **FIRE EXTGH CPG** circuit breaker (CB15). Check for short between (A76)J1-H and ground.  
**Does short exist?**
  - YES Refer to TM 1-1520-238-T-6 to troubleshoot circuit protection system (dc emergency bus - pilot station).
  - NO Go to step 2.
2. Detach P176. On **CPG** glareshield fire extinguisher panel, set **FIRE BTL** switch to **OFF**, check for short between P463-H and ground.  
**Does short exist?**
  - YES Go to step 3.
  - NO Go to step 4.

3. Detach (A322)P1. Check for short between (A322)P1-A14 and chassis ground.  
**Does short exist?**
  - YES Replace CPG glareshield fire extinguisher panel (TM 55-1520-238-23).
  - NO Repair shorted wire: P463-H and J1039-B11, J1039-A14 and J914-A16, P914-A16 and P176-H. Go to paragraph 12-133.
4. Check for short between (A138)J1-H and chassis ground.  
**Does short exist?**
  - YES Replace pilot **APU** fire test panel (TM 55-1520-238-23).
  - NO Go to step 5.
5. Check for short between P176-A and ground.  
**Does short exist?**
  - YES Go to step 6.
  - NO Go to step 7.
6. Detach P748. Check for short between P176-A and ground.  
**Does short exist?**
  - YES Repair shorted wire between: J176-A and P914-A5, J914-A5 and P748-g. Go to paragraph 12-133.
  - NO Replace multi-channel dimming controller (TM 55-1520-238-23).
7. Check for short between P176-D and ground.  
**Does short exist?**
  - YES Go to step 8.
  - NO Go to step 9.

**12-156. FIRE EXTGH CPG CIRCUIT BREAKER (CB15) - DOES NOT STAY CLOSED (cont)**

**12-156**

- |   |  |
|---|--|
| <p>8. Detach P748. Check for short between P176-D and ground.<br/><b>Does short exist?</b></p> <p>    YES      Repair shorted wire between: P176-D and P914-A4, J914-A4 and P748-K. Go to paragraph 12-133.</p> <p>    NO      Replace multi-channel dimming controller (TM 55-1520-238-23).</p> <p>9. On CPG fire extinguisher panel, pull CPG <b>ENG 1</b> and <b>ENG 2 FIRE EXTINGUISHER</b> switches with <b>FIRE BTL</b> switch set to <b>PRI</b>. Check for short between P463-H and ground.<br/><b>Does short exist?</b></p> <p>    YES      Go to step 10.</p> <p>    NO      Go to step 14.</p> <p>10. Check for short between (A322)P1-B2 and chassis ground.<br/><b>Does short exist?</b></p> <p>    YES      Replace CPG glareshield fire extinguisher panel (TM 55-1520-238-23).</p> <p>    NO      Go to step 11.</p> <p>11. Check for short between J1039-B2 and ground.<br/><b>Does short exist?</b></p> <p>    YES      Go to step 12.</p> <p>    NO      Go to step 20.</p> <p>12. Check for short between P475-B16 and ground.<br/><b>Does short exist?</b></p> <p>    YES      Repair shorted wire between: P475-B16 and J757-2. (E100): P1-2 and P1-1. Go to paragraph 12-133.</p> <p>    NO      Go to step 13.</p> | <p>13. Check for short between:<br/><b>(AAH)</b> P475-B2 and ground.<br/><b>(ABG)</b> P475-A14 and ground.<br/><b>Does short exist?</b></p> <p>    YES      Repair shorted wire between: <b>(AAH)</b> J1039-B2 and P475-B2. <b>(ABG)</b> J1039-B2 and P475-A14. Go to paragraph 12-133.</p> <p>    NO      Replace pilot fire extinguisher panel (TM 55-1520-238-23).</p> <p>14. Check for short between (A322)P1-B7 and chassis ground.<br/><b>Does short exist?</b></p> <p>    YES      Replace CPG glareshield fire extinguisher panel (TM 55-1520-238-23).</p> <p>    NO      Go to step 15.</p> <p>15. Check for short between J1039-B7 and ground.<br/><b>Does short exist?</b></p> <p>    YES      Go to step 16.</p> <p>    NO      Go to step 18.</p> <p>16. Check for short between P475-B12 and ground.<br/><b>Does short exist?</b></p> <p>    YES      Repair shorted wire between: P475-B12 and J758-3. (E100): P1-3 and P1-2. Go to paragraph 12-133.</p> <p>    NO      Go to step 17.</p> |
|---|--|



**12-156. FIRE EXTGH CPG CIRCUIT BREAKER (CB15) - DOES NOT STAY CLOSED (cont)**

**12-156**

17. Check for short between P475-B6 and ground.  
**Does short exist?**

YES Repair shorted wire between P475-B6 and J1039-B7.  
Go to paragraph 12-133.

NO Replace pilot fire extinguisher panel (TM 55-1520-238-23).

18. Check for short between P475-B15 and ground.  
**Does short exist?**

YES Repair shorted wire between: P475-B15 and J758-2.  
(E100):  
P1-2 and P1-10.  
Go to paragraph 12-133.

NO Go to step 19.

19. Check for short between P475-B3 and ground.  
**Does short exist?**

YES Repair shorted wire between P475-B3 and J1039-B3.  
Go to paragraph 12-133.

NO Replace pilot fire extinguisher panel (TM 55-1520-238-23).

20. Check for short between P475-B11 and ground.  
**Does short exist?**

YES Repair shorted wire between: P475-B11 and J757-3.  
(E100):  
P1-3 and P1-2.  
Go to paragraph 12-133.

NO Go to step 21.

21. Check for short between:  
**(AAH)** P475-B8 and ground.  
**(ABG)** P475-A15 and ground.  
**Does short exist?**

YES Repair shorted wire between:  
**(AAH)** J1039-B10 and P475-B8.  
**(ABG)** J1039-B10 and P475-A15.  
Go to paragraph 12-133.

NO Replace pilot fire extinguisher panel (TM 55-1520-238-23).

END OF TASK



# CHAPTER 13

## ENVIRONMENTAL CONTROL SYSTEM

### CHAPTER INDEX

<u>Para Title</u>	<u>Para No.</u>
<b>SECTION I. EQUIPMENT DESCRIPTION AND DATA</b>	
Equipment Characteristics, Capabilities, and Features .....	13-1
Location and Description of Major Components .....	13-2
Equipment Data .....	13-3
Equipment Configuration .....	13-4
Safety, Care and Handling of Equipment .....	13-5
Controls and Indicators .....	13-6
<b>SECTION II. THEORY OF OPERATION</b>	
System Description .....	13-7
Multiplex Read Codes .....	13-8
<b>SECTION III. TROUBLESHOOTING PROCEDURES</b>	
Electrical Component Location and Configuration (ECLC) Index .....	13-9
Environmental Control System - Power Up .....	13-10
Environmental Control System - Power Down .....	13-11
Environmental Control System - Maintenance Operational Check .....	13-12
Environmental Control System - Wiring Interconnect Diagram .....	13-13

## SECTION I. EQUIPMENT DESCRIPTION AND DATA

---

### 13-1. EQUIPMENT CHARACTERISTICS, CAPABILITIES, AND FEATURES

13-1

a. **Characteristics.** The environmental control system (ECS) supplies warmed or cooled air to the crew stations and avionics bays.

b. **Capabilities and Features.** Warmed or cooled air, from the pressurized air system (PAS) is supplied to the crew stations and forward avionics bay through air ducts. The ECS air temperature is controlled by the pilot. Exhaust fans in the forward and aft avionics bay and the electrical power distribution box also provide cooling. Ambient ram air flow is also provided to the cabin through an outside air vent.

c. **Fire Pull Handles.** When **ENG 1** or **ENG 2 FIRE PULL** handle is pulled, it energizes the ENCU relay to close the ECS shutoff valve. When the ECS shutoff valve closes, maximum pressurized air is applied to the engine louver system.

---

### 13-2. LOCATION AND DESCRIPTION OF MAJOR COMPONENTS

13-2

The ECS consists of the environmental control unit (ENCU), ECS shutoff valve, ECS air ducts, ECS fans, forward avionics bay (FAB) thermal switches and a manual outside air vent.

a. **ENCU.** The ENCU (fig. 13-1), located on the left side of the aft equipment bay, extracts heat energy from PAS air and cools or heats the air as required to maintain the temperature selected by the pilot. The ENCU consists of a primary heat exchanger, condenser/reheater, cooling turbine fan assembly, temperature control sensor and temperature control valve.

(1) **Primary Heat Exchanger.** The primary heat exchanger, located below the ENCU air inlet duct, partially cools PAS air prior to entering the condenser/reheater.

(2) **Condenser/Reheater.** The condenser/reheater, located aft of the ENCU air outlet duct, further cools the partially cooled air from the primary heat exchanger and collects condensation.

(3) **Cooling Turbine/Fan Assembly.** The cooling turbine/fan assembly, located on the lower aft section of the ENCU, cools the air from the condenser/reheater in its final cooling stage. The turbine extracts heat energy from the air and drives the fan which draws ambient air through the primary heat exchanger and exhausts it overboard.

(4) **Temperature Control Sensor.** The temperature control sensor, located on the ENCU air outlet duct, positions the temperature control valve to maintain the temperature selected by the pilot.

(5) **Temperature Control Valve.** The temperature control valve, located on the right aft section of the ENCU, mixes hot PAS air with cooled turbine discharge air to maintain the pilot's selected temperature.

b. **ECS Shutoff Valve.** The ECS shutoff valve (fig. 13-2), located in the aft equipment bay outboard of the ENCU, provides control of PAS air to the ENCU.

c. **ECS Air Ducts.** The ECS air ducts (fig. 13-3), begin at the ENCU air outlet duct and extend forward to the copilot/gunner (CPG) station and duct air from the ENCU to the crew stations and FABs. The ECS ducts consist of 33 ridged ducts joined by rubber sleeves and attached by hose clamps.

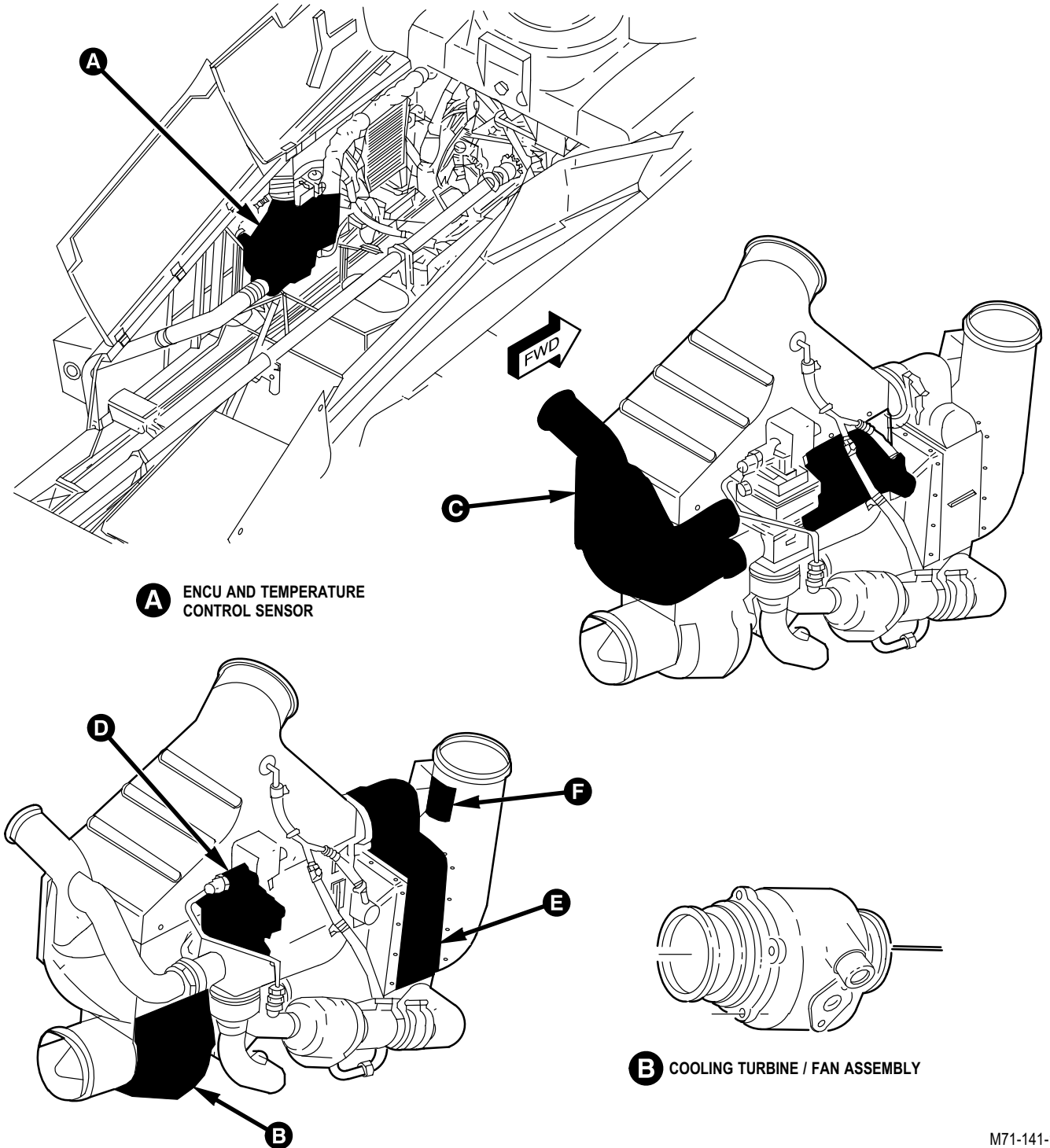

M71-141-1

Figure 13-1. ENCUs Major Component Location (Sheet 1 of 2)

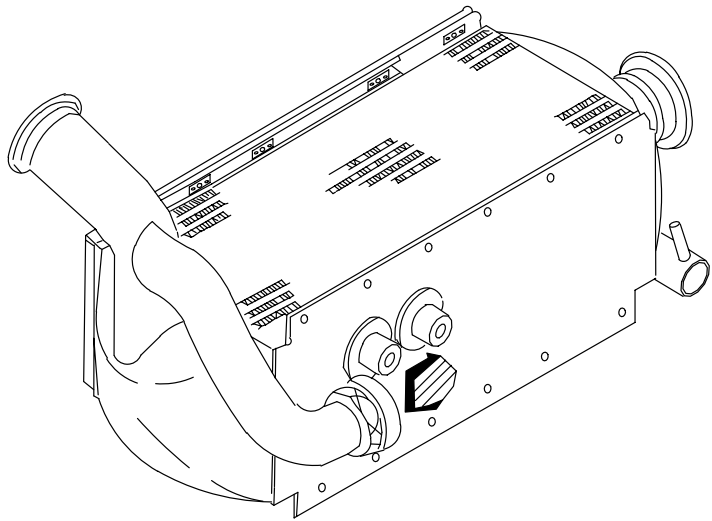

**C** PRIMARY HEAT EXCHANGER

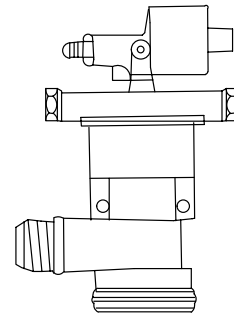

**D** TEMPERATURE CONTROL VALVE

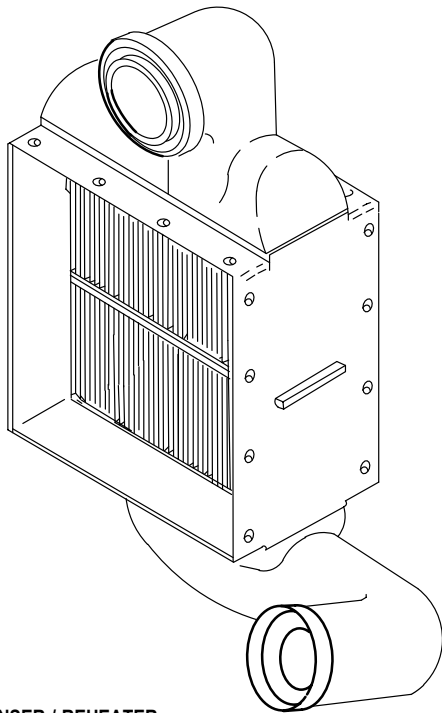

**E** CONDENSER / REHEATER

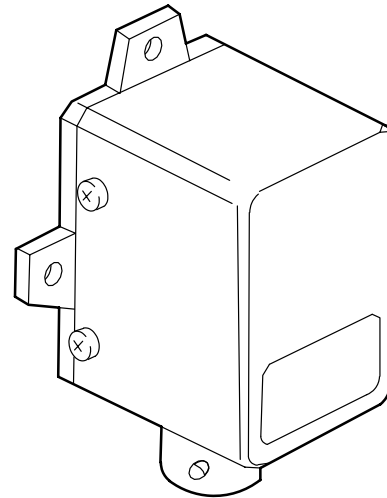

**F** TEMPERATURE CONTROL SENSOR

M71-141-2

Figure 13-1. ENCU Major Component Location (Sheet 2 of 2)

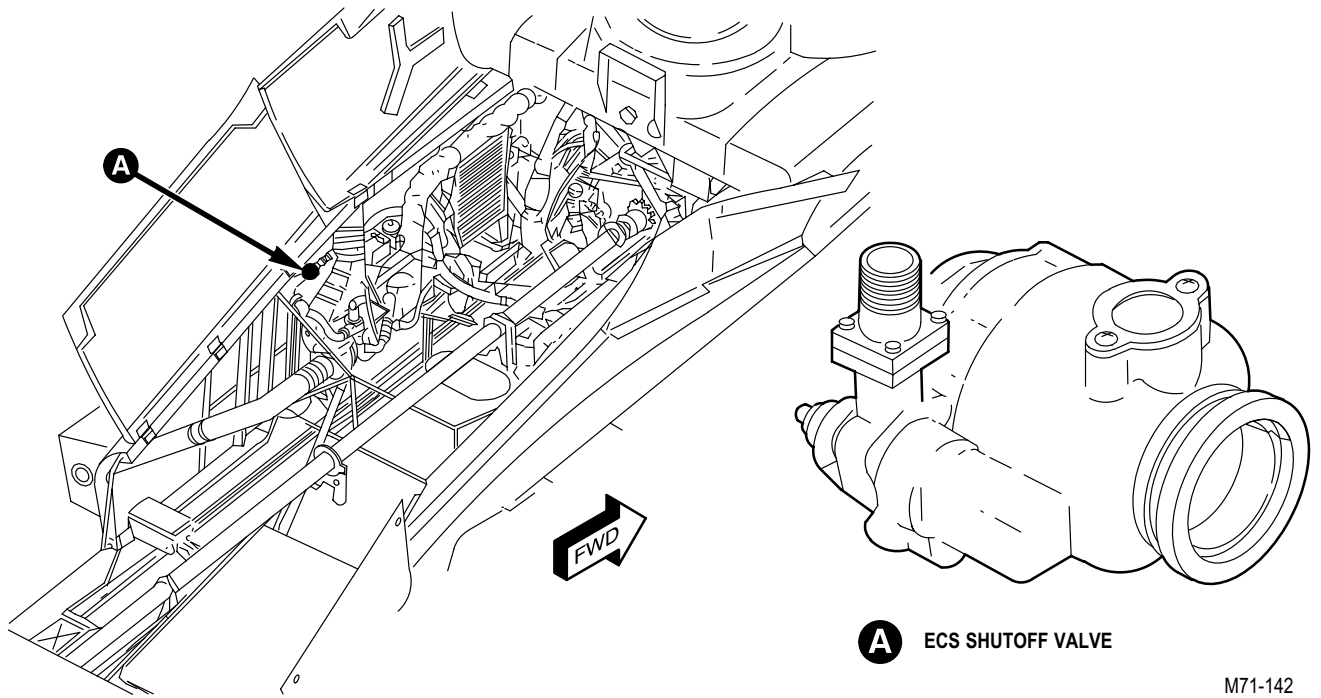

M71-142

Figure 13-2. ECS Shutoff Valve Location

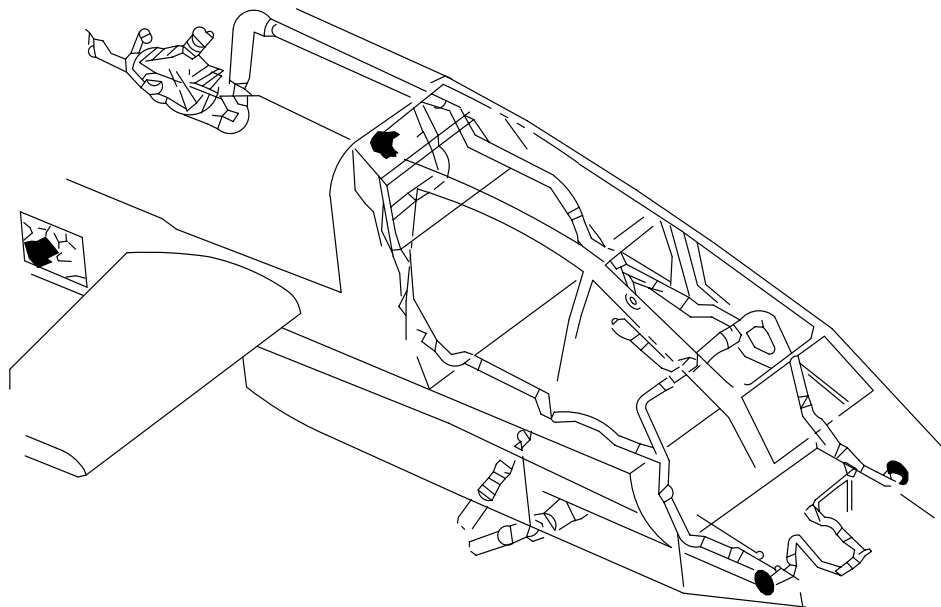

M71-143

Figure 13-3. ECS Air Ducts Location

d. **ECS Fans.** The ECS fans (fig. 13-4) circulate cooling air around electronic and electrical equipment. Two forward vaneaxial fans, 1 in each FAB, are driven by 115 VAC, 3-phase, 2 speed motors. The aft vaneaxial fan, located in the aft equipment bay, is driven by a 115 VAC, 3-phase, single speed motor. The electrical power distribution box fan is driven by a 115 VAC, 3-phase, single speed motor.

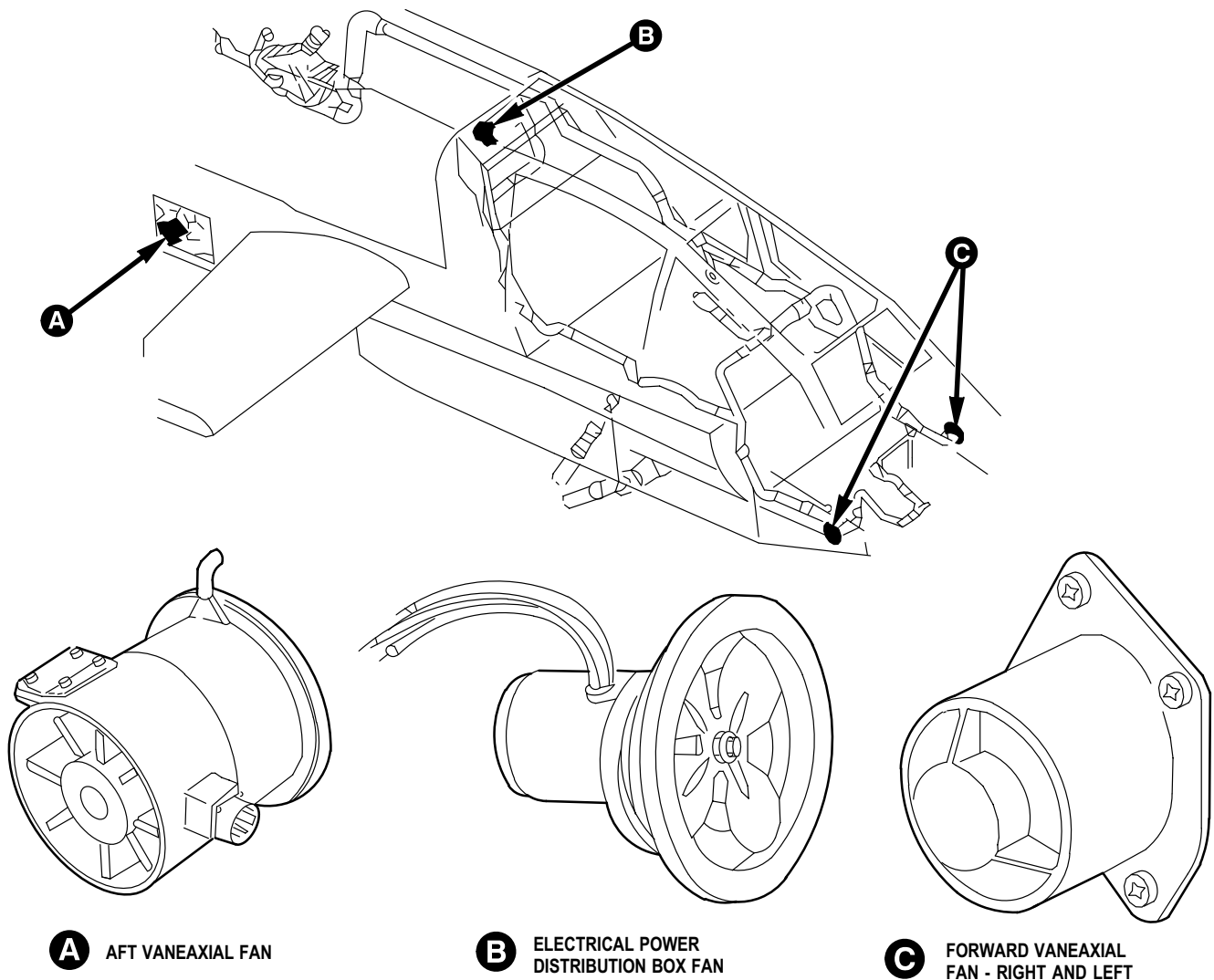

**A** AFT VANEAXIAL FAN

**B** ELECTRICAL POWER DISTRIBUTION BOX FAN

**C** FORWARD VANEAXIAL FAN - RIGHT AND LEFT

M71-144

**Figure 13-4. ECS Fans Location**

e. **FAB Thermal Switches.** The FAB thermal switches (fig. 13-5) are located in the left FAB (S27, S29, S31) and right FAB (S30). Switches S27 and S29 provide a signal to the temperature control sensor when the temperature in the left FAB reaches 75° F (24° C) (S27) and 85° F (29° C) (S29). Switches S30 and S31 provide a warning signal to the pilot station if the temperature in either FAB reaches 105° F (41° C). Switch S56, located in the aft avionics bay, controls the operation of the aft vaneaxial fan. The fan is turned on when the temperature reaches 25° ±10° F (-4° ±6° C) and turned off when the temperature reaches 0° ±10° F (-18° ±6° C).



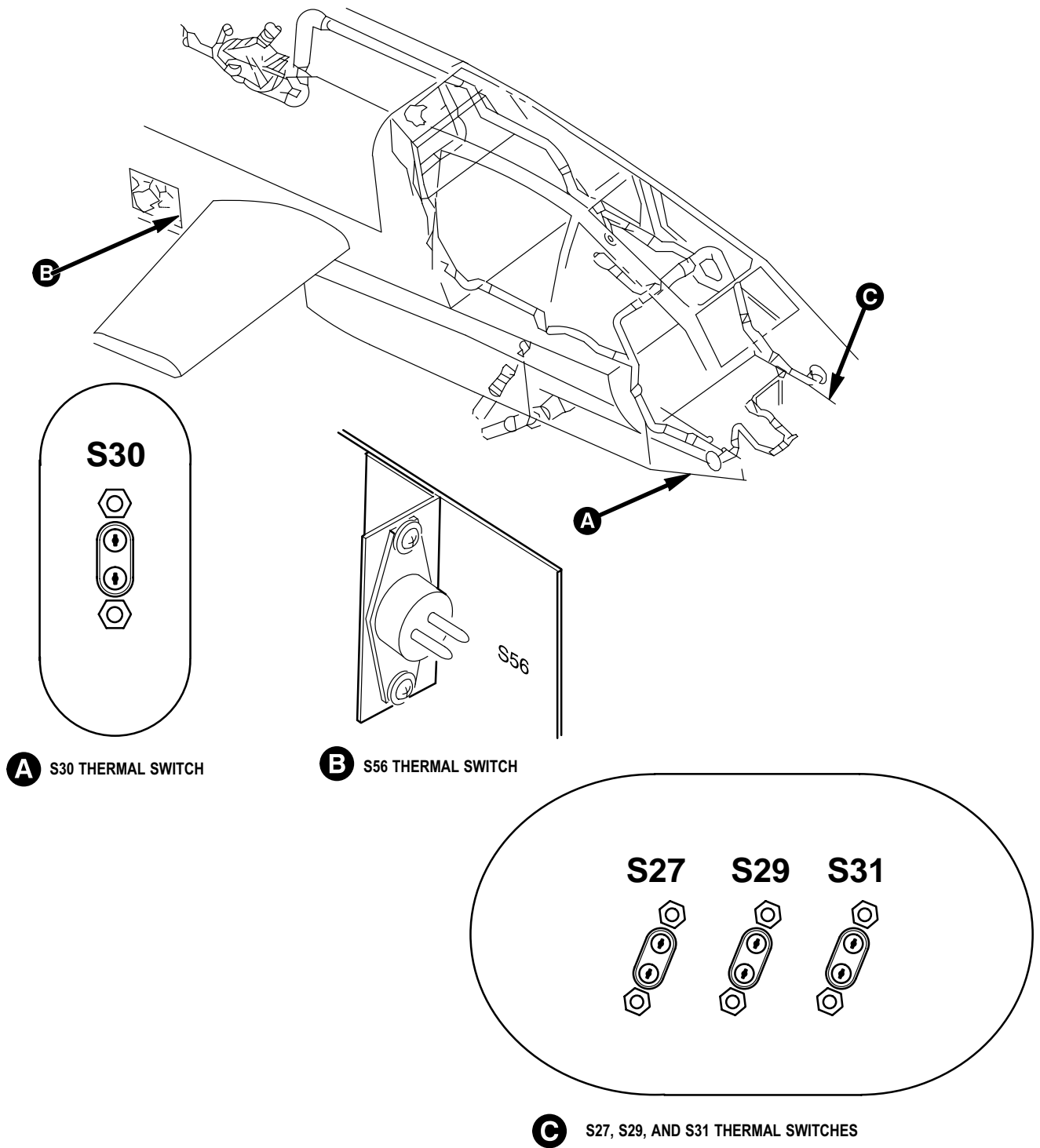

M71-145

Figure 13-5. FAB Thermal Switches Location

**13-2. LOCATION AND DESCRIPTION OF MAJOR COMPONENTS (cont)**

**13-2**

f. **Manual Outside Air Vent.** The manual outside air vent (fig. 13-6), located on the left side of the pilot station, provides ambient ram air to the pilot station.

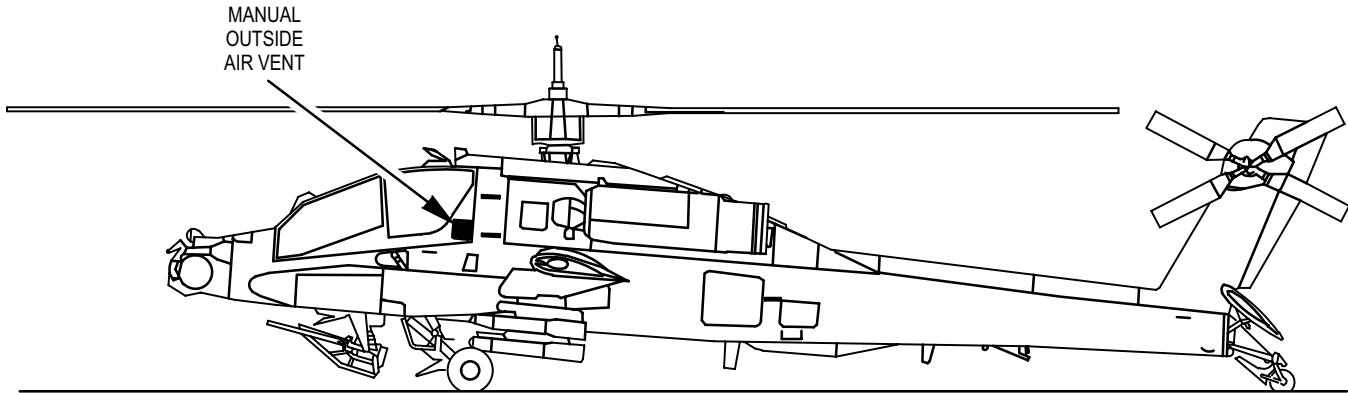

M71-146

**Figure 13-6. Manual Outside Air Vent**

**13-3. EQUIPMENT DATA**

**13-3**

Not applicable.

**13-4. EQUIPMENT CONFIGURATION**

**13-4**

Not applicable.

**13-5. SAFETY, CARE AND HANDLING OF EQUIPMENT**

**13-5**

Not applicable.

**13-6. CONTROLS AND INDICATORS**

**13-6**

The ECS receives mode selects and remote switch inputs from various controls located within the pilot station (fig. 13-7) and CPG station (fig. 13-8). Table 13-1 provides a listing of the controls, switches and associated indicators pertaining to the ECS along with a description of their function.

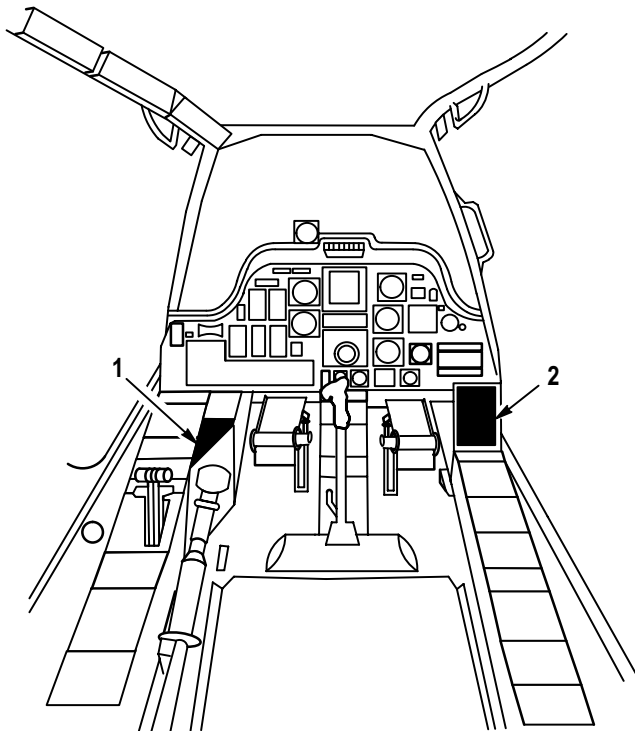

1. PILOT ECS PANEL  
2. PILOT CAUTION / WARNING PANEL

M71-147

Figure 13-7. Pilot Station

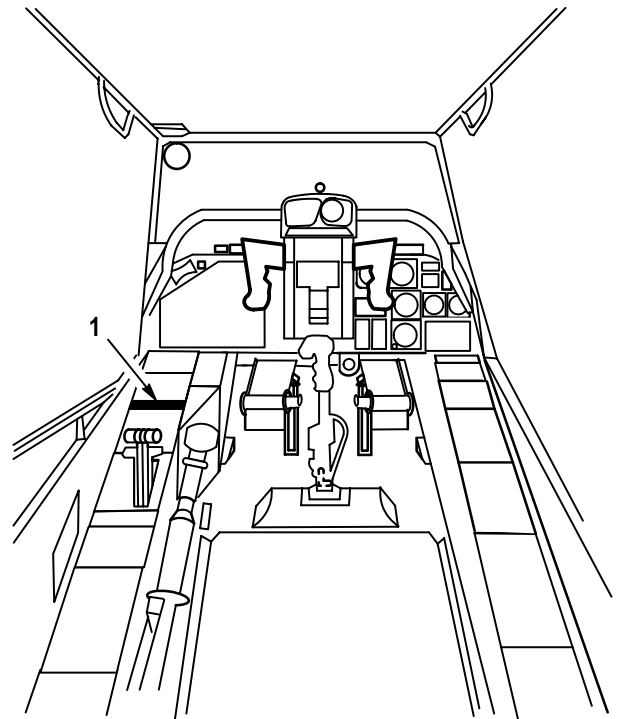

1. CPG AUX / ANTI - ICE PANEL

M71-148

Figure 13-8. CPG Station

Table 13-1. ECS Controls and Indicators

Pilot ECS Panel		
SWITCH/INDICATOR	POSITION	FUNCTION
<b>ENCU</b> switch	<b>ON</b>	Supplies 28 VDC to open the ECS shutoff valve and operate the temperature control sensor.
	<b>OFF</b>	Removes 28 VDC from the ECS shutoff valve and temperature control sensor.
<b>STBY FAN</b> switch	<b>NORM</b>	Enables FAB fans to operate at low speed.
	<b>STBY FAN</b>	Enables FAB fans to operate at high speed.
<b>TEMP</b> switch	<b>COLD</b>	Allows a minimum ECS air temperature of 36° F (2° C).
	<b>WARM</b>	Allows a maximum ECS air temperature of 170° F (77° C).

Table 13-1. ECS Controls and Indicators (cont)

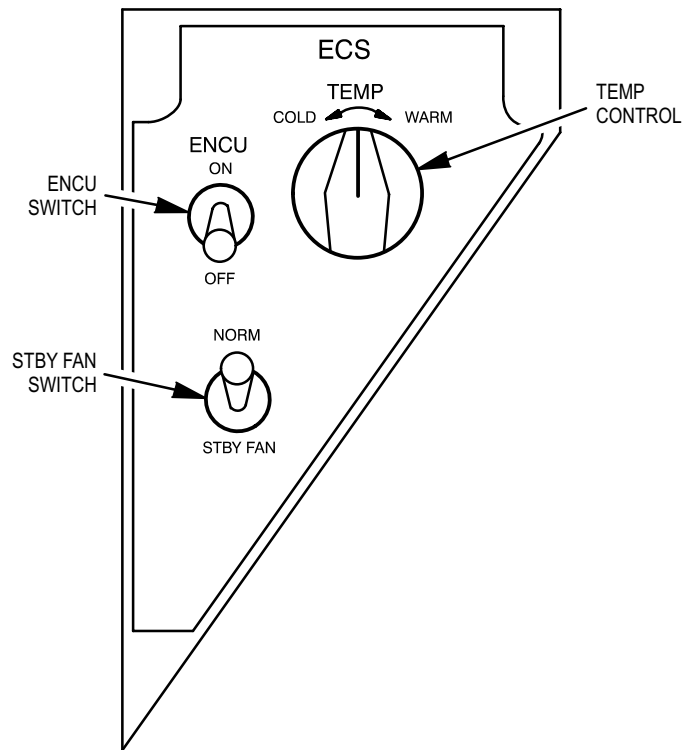

M71-149

Pilot ECS Panel

CPG AUX/ANTI-ICE Panel		
SWITCH/INDICATOR	POSITION	FUNCTION

<b>STBY FAN</b>	<b>STBY FAN</b>	Enables FAB fans to operate at high speed.
	<b>OFF</b>	Allows FAB fans to be controlled by <b>STBY FAN</b> switch on pilot <b>ECS</b> panel.

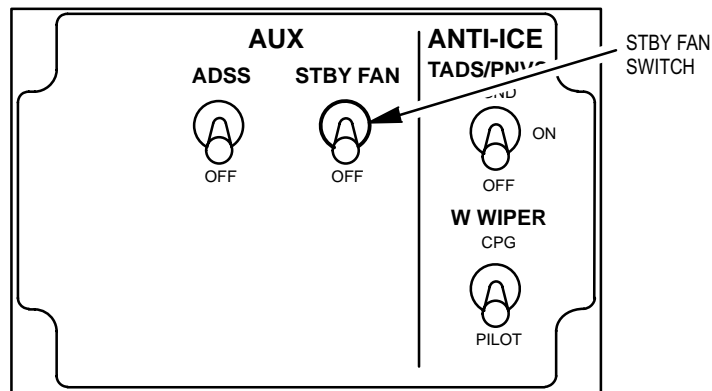

M71-150

CPG AUX/ANTI-ICE Panel

13-6. CONTROLS AND INDICATORS (cont)

13-6

Table 13-1. ECS Controls and Indicators (cont)

Pilot Caution/Warning Panel		
SWITCH/INDICATOR	POSITION	FUNCTION

ECS indicator	AMBER	Lights when temperature in either FAB reaches 105° F (41° C).
---------------	-------	---

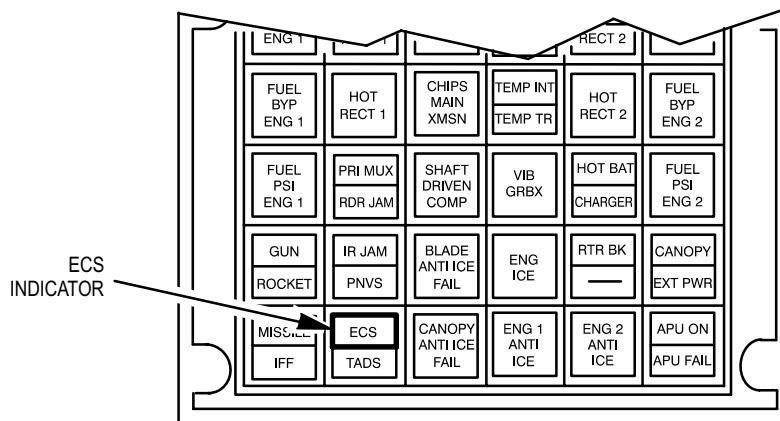

M71-151

Pilot Caution/Warning Panel

SECTION II. THEORY OF OPERATION

13-7. System Description

13-7

a. **ECS.** The ECS (fig 13-9) supplies conditioned (warmed or cooled) air to the crew stations and FABs.

(1) Ambient and PAS air is drawn through the primary heat exchanger where the air is partially cooled. The air is then drawn through the condenser/reheater where it is cooled further and moisture is collected by the condenser. The cooling turbine/fan assembly cools the air from the condenser/reheater in its final cooling stage. The turbine fan assembly, attached to the end of the cooling turbine shaft, draws ambient air through the primary heat exchanger and exhausts it overboard. Conditioned air is supplied to the crew stations and avionics bays through air ducts.

(2) The ECS temperature is controlled by the pilot **ECS** panel. The desired temperature signal is sent from the **ECS** panel to the temperature sensor/control where it is compared with the ECS air outlet temperature. The temperature sensor/control positions the temperature control valve to mix hot PAS air with cooled turbine discharge air to maintain the temperature selected by the pilot.

(3) Vaneaxial fans draw conditioned air from the ECS ducts and exhausts it around the electronic components in each FAB for additional cooling.

(4) Exhaust fans in the aft avionics bay and the electrical power distribution box also provide cooling for the electronic components.

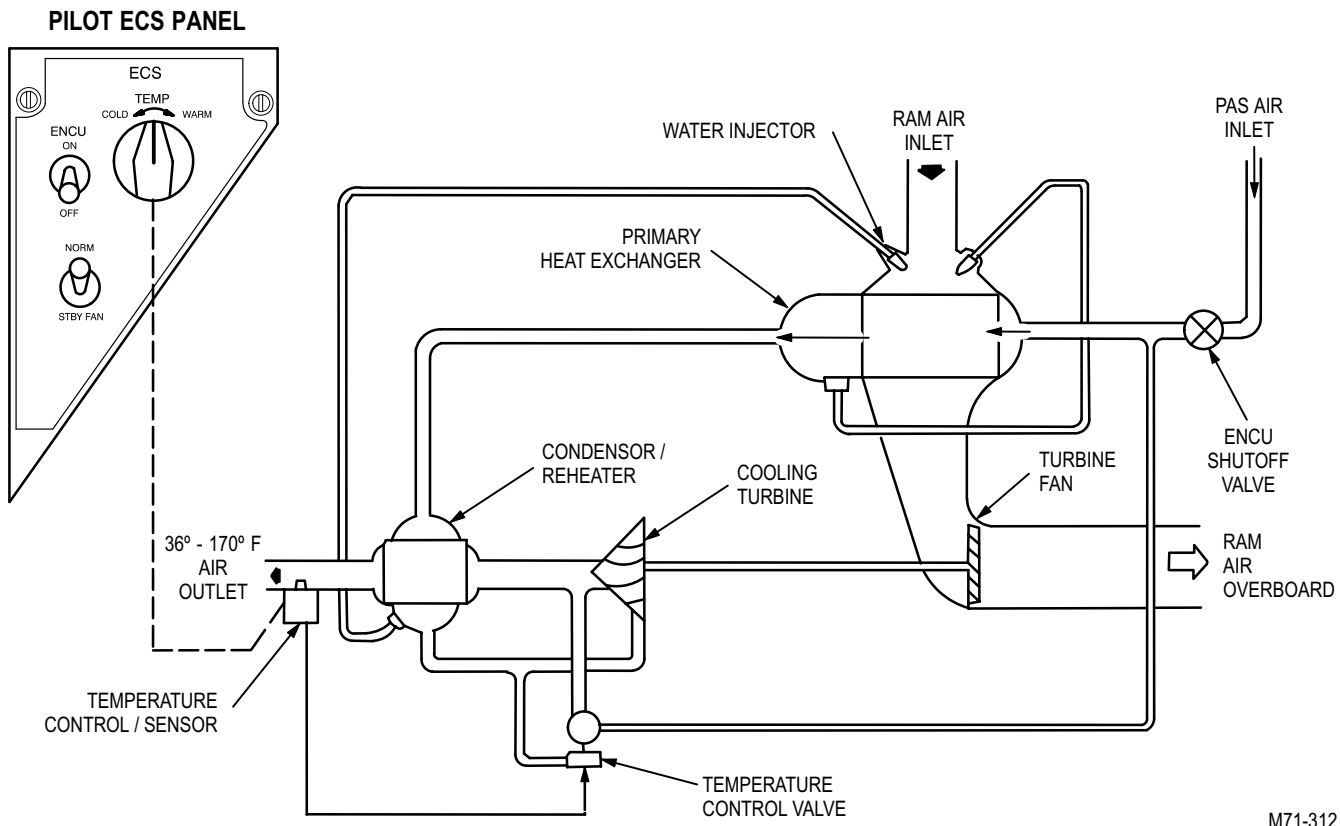

M71-312

Figure 13-9. ECS Operation

b. **Purpose.** The purpose of the ECS is to provide conditioned air for the crew stations and FAB, and to provide exhaust fans for the electrical power distribution box and aft avionics bay.

c. **System Operation** (fig. 13-10). **ECS CAB** circuit breaker (CB76) supplies 28 VDC through the CPG **AUX/ANTI-ICE** panel to the aft avionics fan relay, FAB fans standby relay contacts to energize the FAB fans normal relay, and pilot **ECS** panel. **ECS FAB FANS** circuit breaker (CB88) supplies 115 VAC through the energized contacts of the FAB fans normal relay to the normal low speed windings of the left and right FAB vaneaxial fans. When the CPG **STBY FAN** switch is set to **STBY FAN** or the pilot selects **STBY FAN**, the FAB fans standby relay energizes, de-energizing the FAB fans normal relay and applying 115 VAC to the standby high speed windings of the left and right FAB vaneaxial fans. **ECS AFT FAN** circuit breaker (CB75) supplies 115 VAC to the electrical power distribution box fan and the aft avionics bay fan through the aft avionics fan relay. The aft avionics fan relay is controlled by the aft avionics bay thermostat. The aft avionics fan operates above 65° F (18° C). The aft avionics bay thermostat closes at approximately 65° F (18° C) energizing the aft avionics fan relay, removing aft avionics fan power.

---

**13-7. SYSTEM DESCRIPTION (cont)**

---

13-7

(1) The pilot **ENCU** switch in the **ON** position supplies 28 VDC to the ECS temperature control sensor, thermal switches S27, S29, S30, and S31, engine starter dropout relay, ECS air shutoff valve/engine start interlock relay, ENCU relay, and ECS shutoff valve. The engine starter dropout relay, ECS air shutoff valve/engine start interlock relay, and ENCU relay in the de-energized position provide a 28 VDC path to energize the ECS shutoff valve open. When the engines are started the engine starter dropout and ECS air shutoff valve/engine start interlock relays energize, closing the ECS shutoff valve. When the fire pull handles are pulled, the ENCU valve is energized, closing the ECS shutoff valve.

(2) Setting of the **TEMP** control on the **ECS** panel provides a reference to the ECS temperature control. The ECS temperature control compares the selected temperature to the monitored temperature and provides a signal output to the temperature control valve. The temperature control valve mixes the hot and cooled air to maintain the selected temperature.

(3) Thermal switches S27, S29, S30, and S31 monitor the FABs temperature. Thermal switches S27 and S29 are paralleled with the temperature control reference resistors. Thermal switch S27 opens increasing the reference resistance when the temperature reaches 75° F (24° C). The opening of S27 reduces the temperature by 15° F (9° C). Thermal switch S29 opens increasing reference resistance when the FAB temperature reaches 85° F (29° C). The opening of S29 reduces the temperature an additional 15° F (9° C). Thermal switches S30 or S31 close when the temperature in the FABs reach 105° F (41° C), lighting the **ECS** indicator on the pilot caution/warning panel.

(4) Hot PAS air (fig. 13-11) enters the ENCU through the ECS shutoff valve to the heat exchanger and the temperature control valve. The heat exchanger partially cools the PAS air by ram air through the cooling air inlet and water injection in the heat exchanger. The condenser/reheater further cools PAS air and collects water condensation. The cooled air is ducted from the condenser/reheater to the cooling turbine. The cooling turbine extracts more heat and drives the turbine fan which exhausts ambient air overboard. The temperature control sensor monitors cooled air and provides outputs to the temperature control valve which mixes hot air with cooled air to maintain the temperature selected by the pilot. The cooled air is ducted to the crew stations to maintain comfort and to cool the TADS/PNVS turret.

(5) The FAB fans draw air from the CPG station and cool avionics equipment before exhausting air overboard. Thermal switch S27 signals the temperature control sensor via the pilot **ECS** panel to reduce the temperature 15° F (9° C) when the temperature reaches 75° F (24° C). Thermal switch S29 signals the temperature control sensor via the pilot **ECS** panel to reduce the temperature an additional 15° F (9° C) when the FAB temperature reaches 85° F (29° C). Thermal switches S30 or S31 lights the **ECS** indicator on the pilot caution/warning panel when FAB temperature reaches 105° F (41° C).

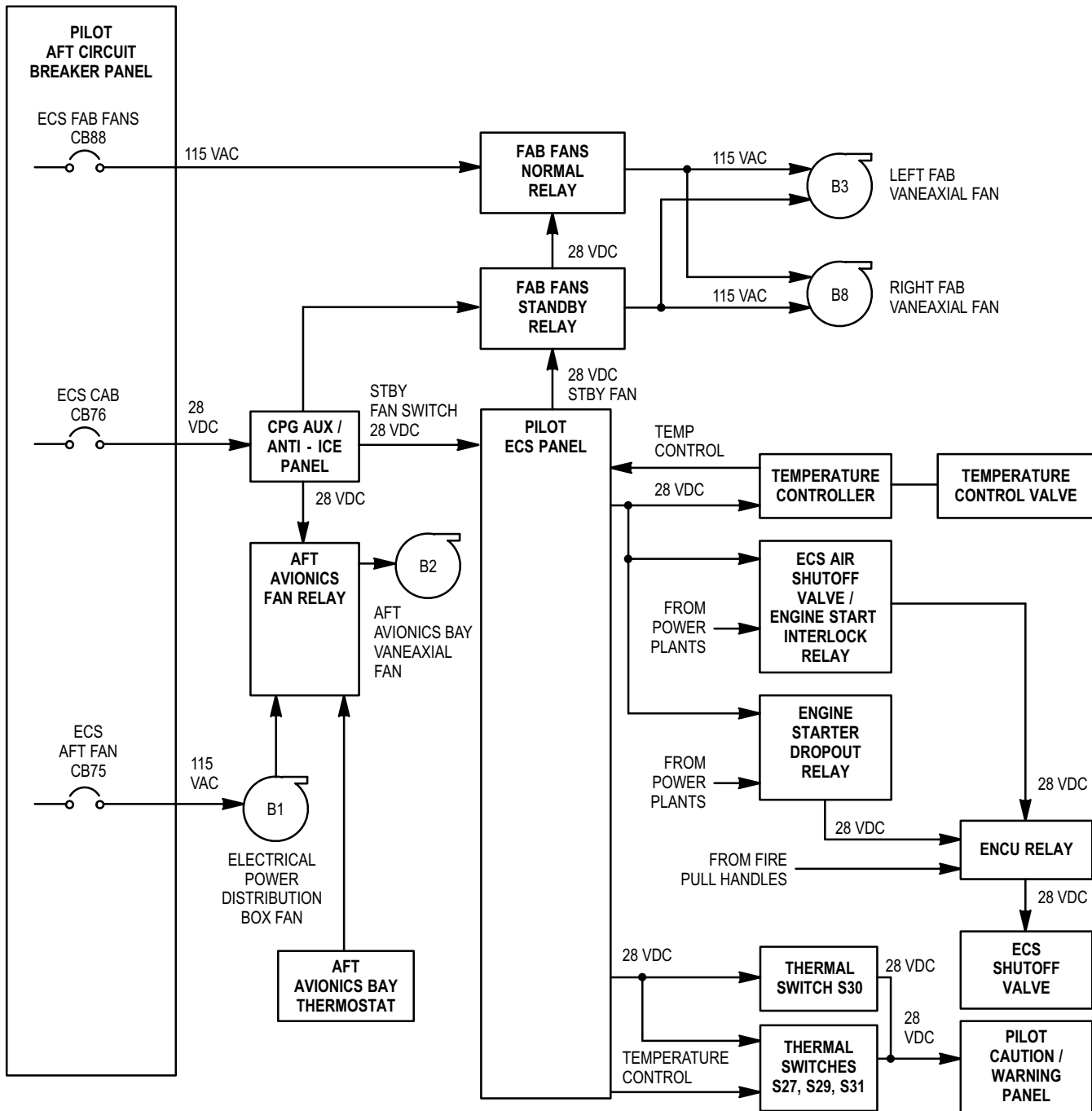

M71-237

Figure 13-10. ECS Functional Block Diagram



13-7. SYSTEM DESCRIPTION (cont)

13-7

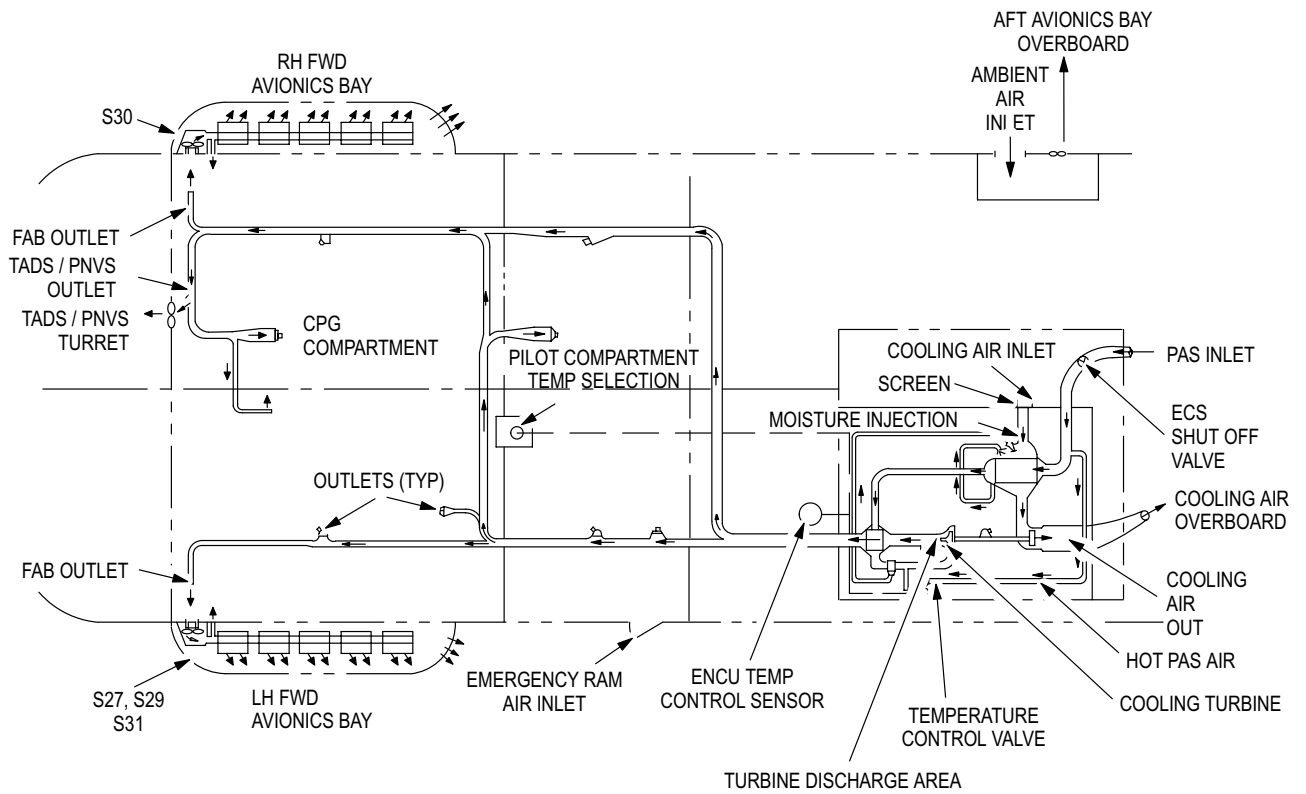

M71-236

Figure 13-11. ECS System Flow Diagram

13-8. MULTIPLEX READ CODES

13-8

Not applicable.

## SECTION III. TROUBLESHOOTING PROCEDURES

## 13-9. ELECTRICAL COMPONENT LOCATION AND CONFIGURATION (ECLC) INDEX

13-9

Use the information in Table 13-2 to find the electrical components and their connectors that you have to locate to perform the troubleshooting tasks in this chapter. Table 13-2 includes locator illustrations which supplement the ECLC listing. The entry in the grid area column in the listing tells you where to find the component in the illustrations.

*Table 13-2. Electrical Component Location and Configuration (ECLC) Index Listing*

FROM COLUMN		TO COLUMN		Grid Area	Access
Connector Ref Des	Component/Harness	Connector Ref Des	Component/Harness		
P1	W605	J1	A402	20A	PLT STATION
P18	W118	J1	A106	13C	PLT STATION
P2	W605	J2	A402	20C	PLT STATION
P283	W108	J1	B2	25C	R295 DOOR
P285	W119	J1	A43	22A	L200 PANEL
P286	W119	J1	L38	21A	L200 PANEL
P287	W119	J1	L39	21A	L200 PANEL
P430	W108	J6	A402	18B	PLT STATION
P433	W119	J20	A402	19E	PLT STATION
P466	W118	J14	A326	9C	CPG STATION
P473	W119	J6	A326	11C	CPG STATION
P477	W119	J8	A326	12E	CPG STATION
P480	W118	J16	A326	9B	CPG STATION
P762	W119	J1	A417	3C	CPG STATION
P908	W118	J908	W119	5C	CPG STATION

13-9. ELECTRICAL COMPONENT LOCATION AND CONFIGURATION (ECLC) INDEX (cont)

13-9

Table 13-2. Electrical Component Location and Configuration (ECLC) Index Listing (cont)

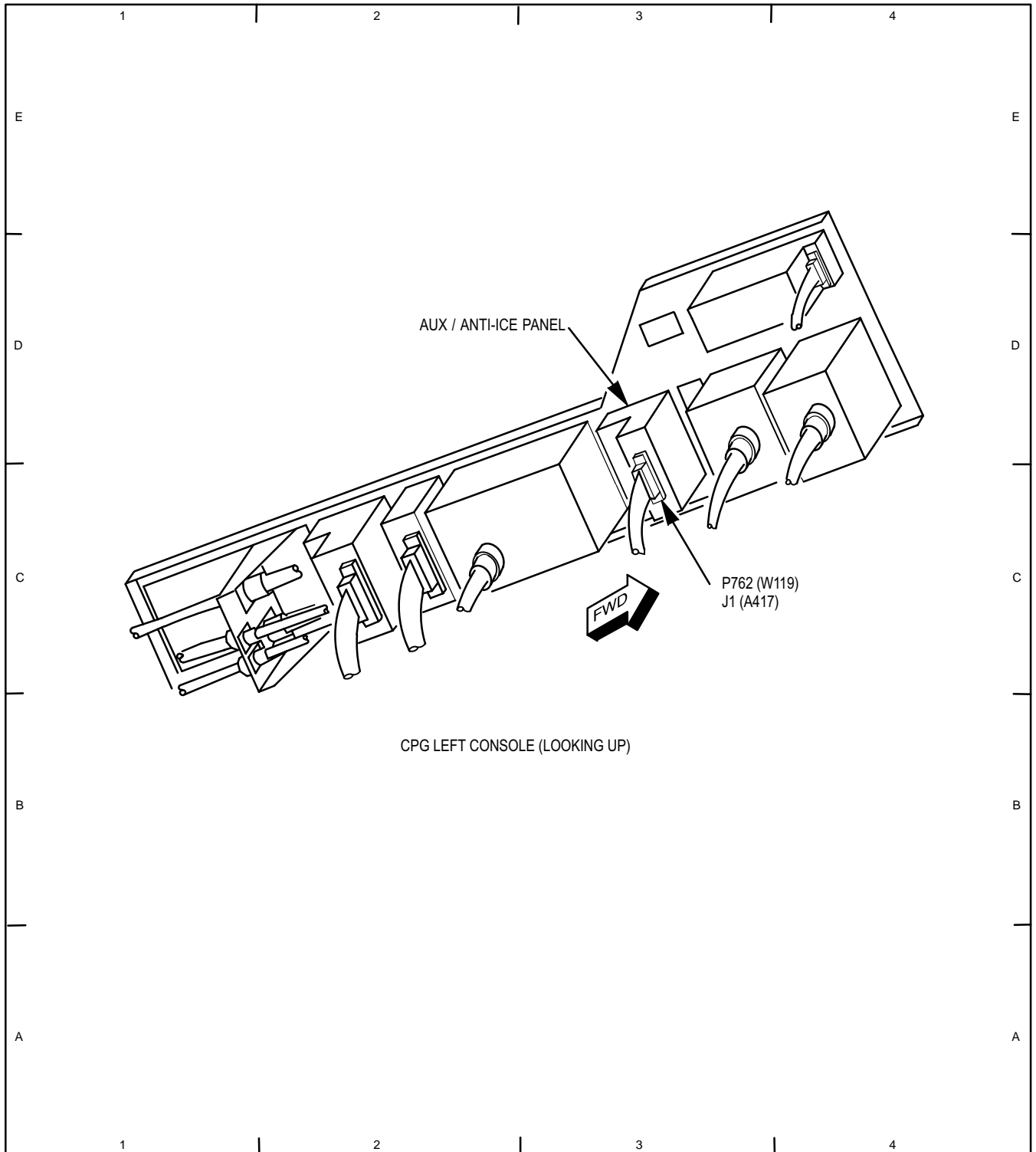

M71-282

Table 13-2. Electrical Component Location and Configuration (ECLC) Index Listing (cont)

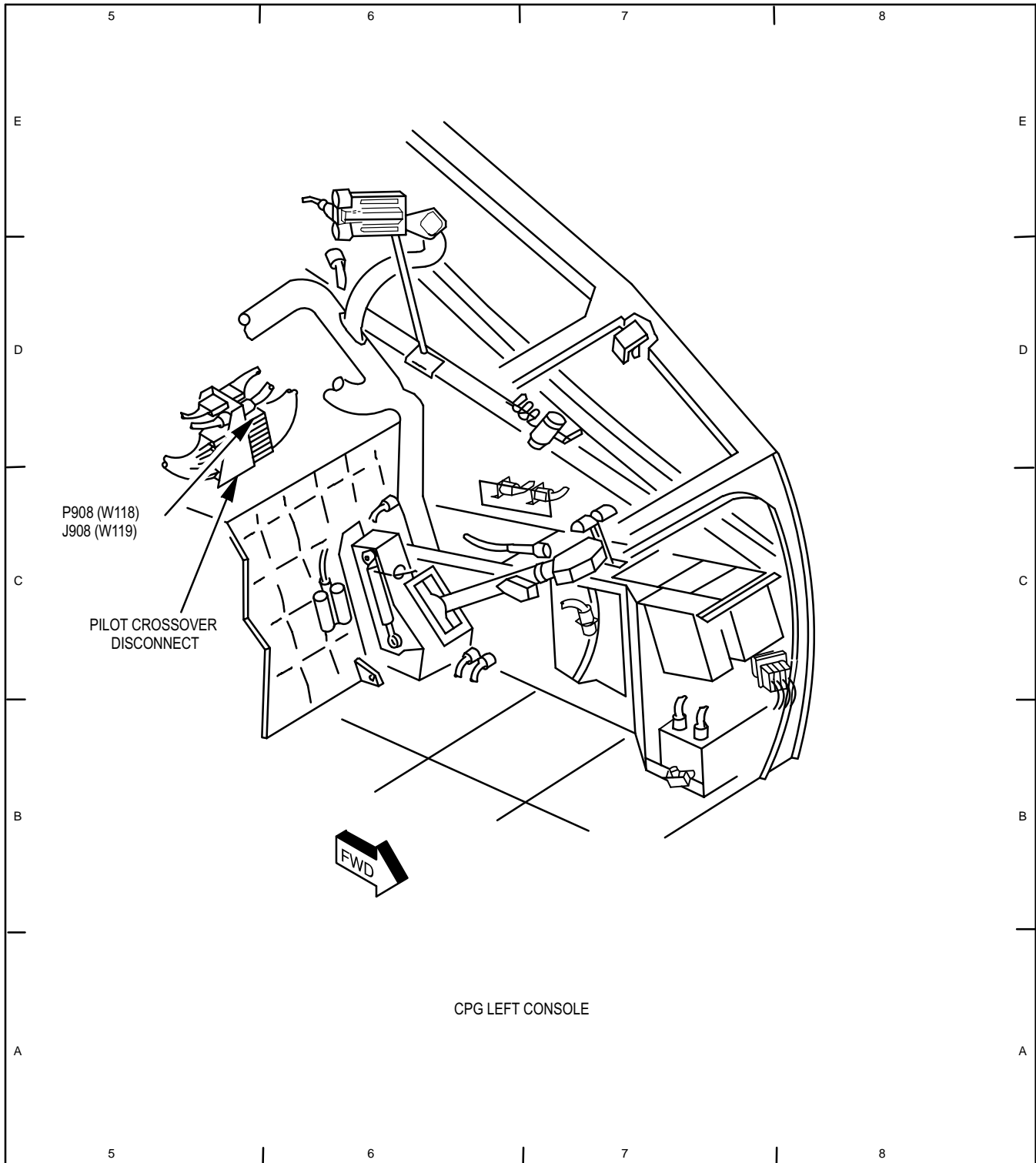

M71-283

13-9. ELECTRICAL COMPONENT LOCATION AND CONFIGURATION (ECLC) INDEX (cont)

13-9

Table 13-2. Electrical Component Location and Configuration (ECLC) Index Listing (cont)

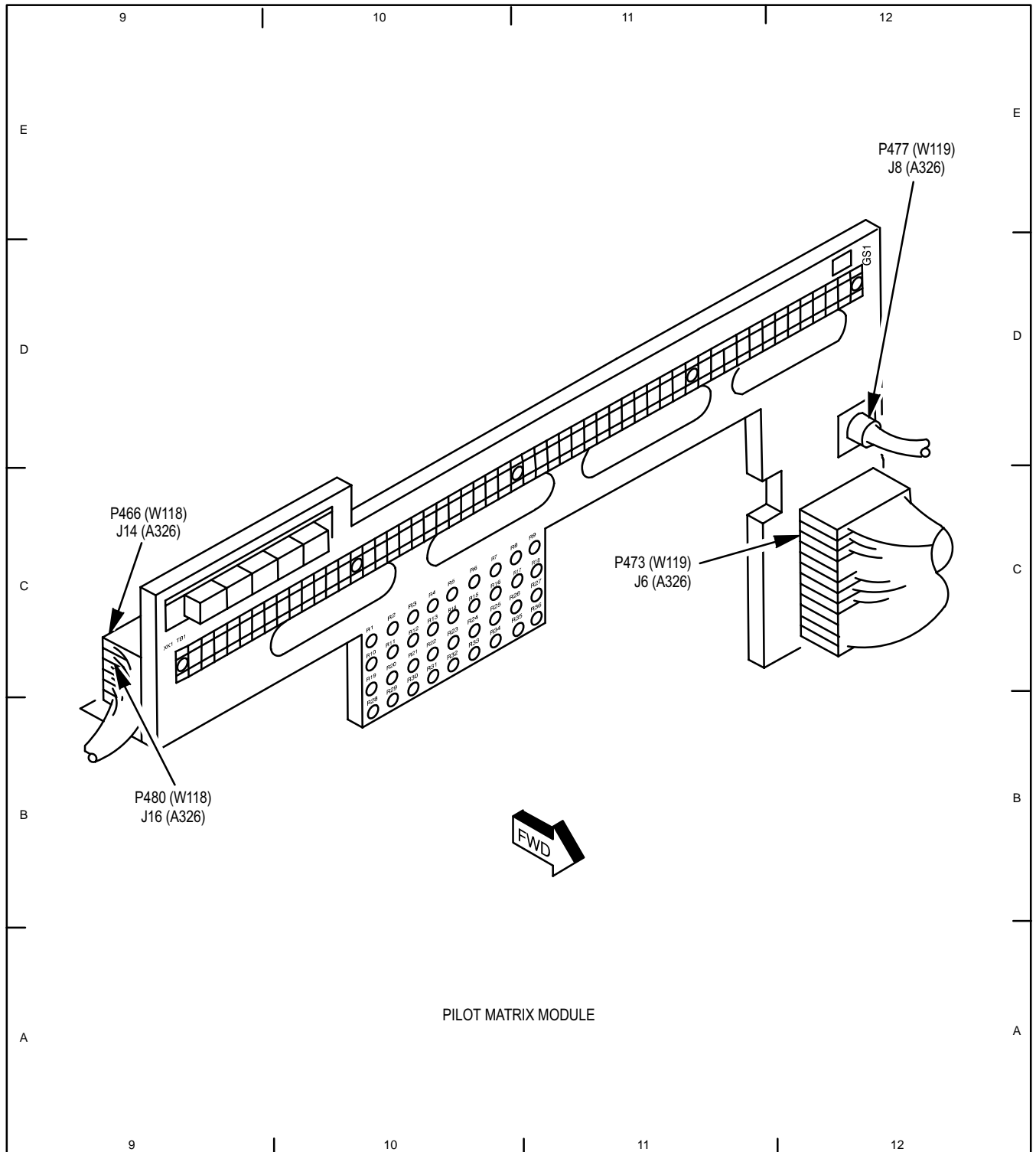

M71-284

Table 13-2. Electrical Component Location and Configuration (ECLC) Index Listing (cont)

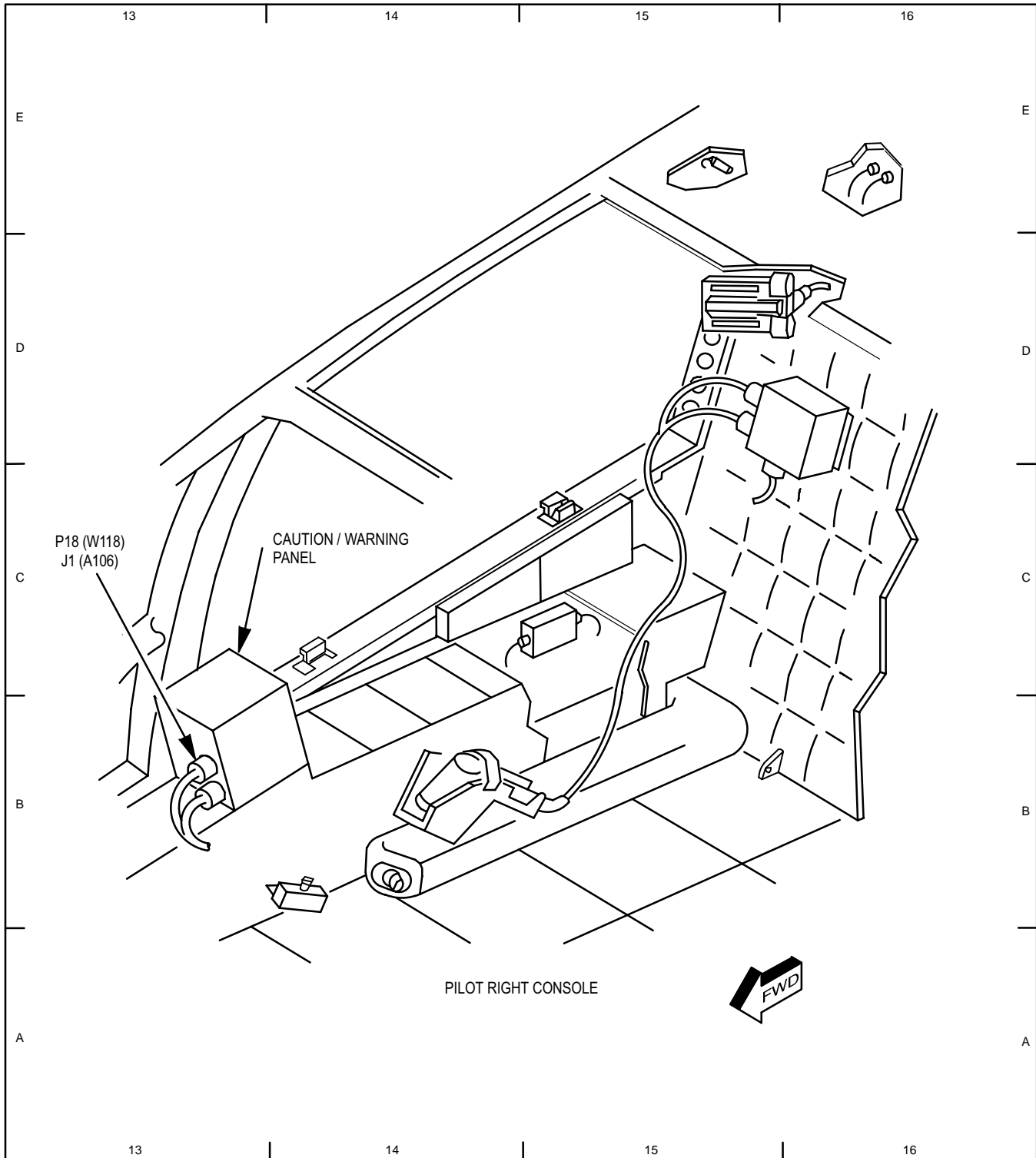

M71-285

13-9. ELECTRICAL COMPONENT LOCATION AND CONFIGURATION (ECLC) INDEX (cont)

13-9

Table 13-2. Electrical Component Location and Configuration (ECLC) Index Listing (cont)

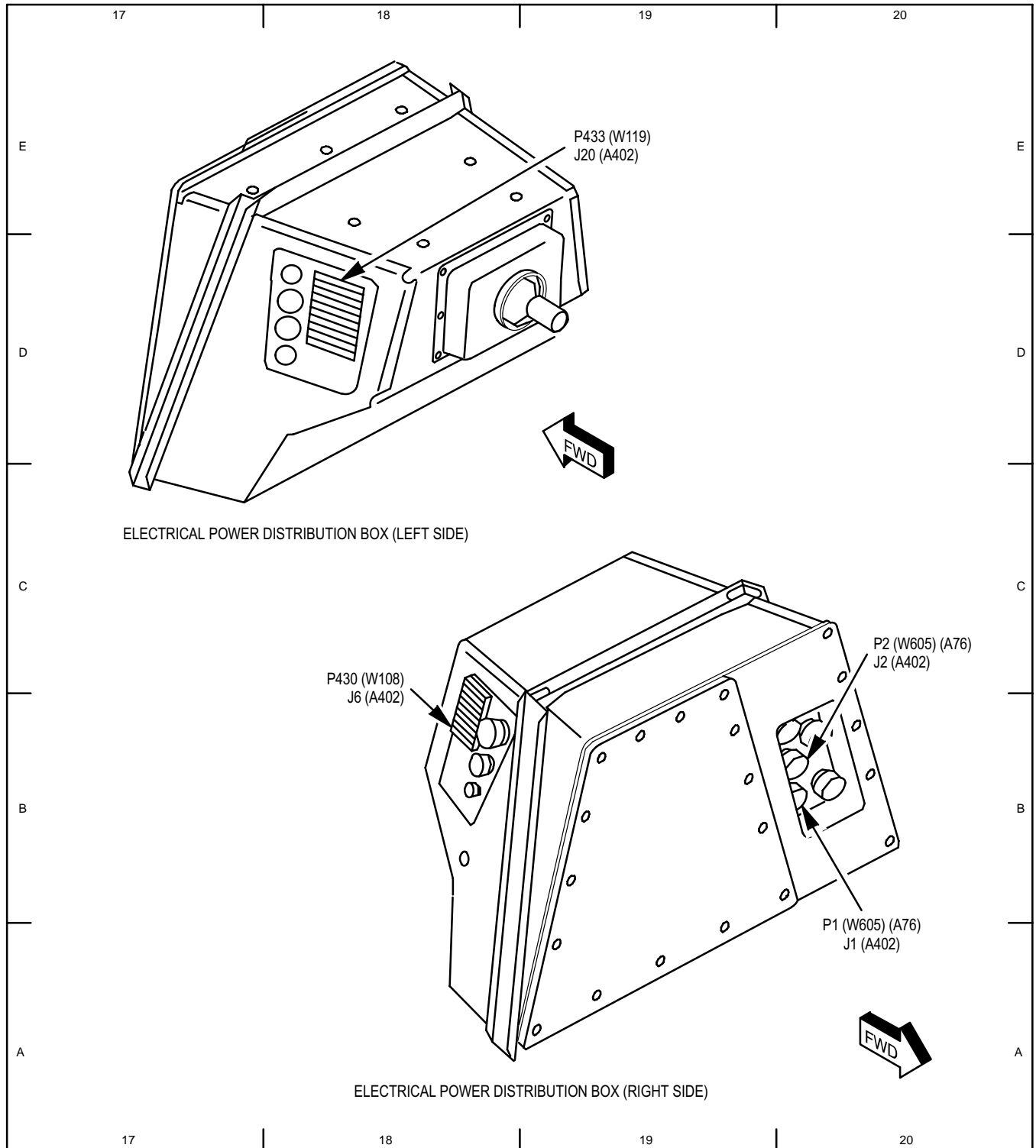

M71-286

Table 13-2. Electrical Component Location and Configuration (ECLC) Index Listing (cont)

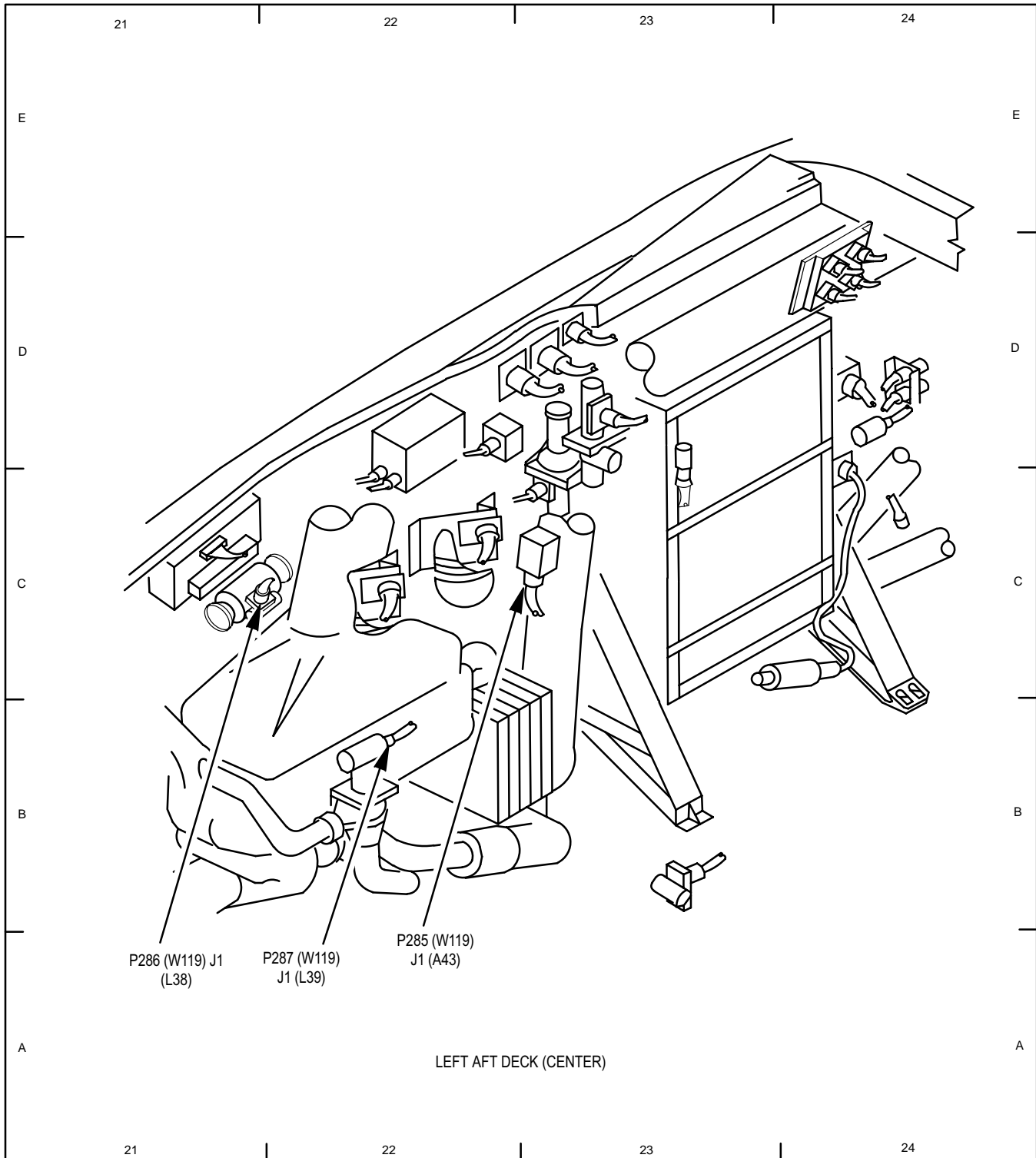

M71-287



13-9. ELECTRICAL COMPONENT LOCATION AND CONFIGURATION (ECLC) INDEX (cont)

13-9

Table 13-2. Electrical Component Location and Configuration (ECLC) Index Listing (cont)

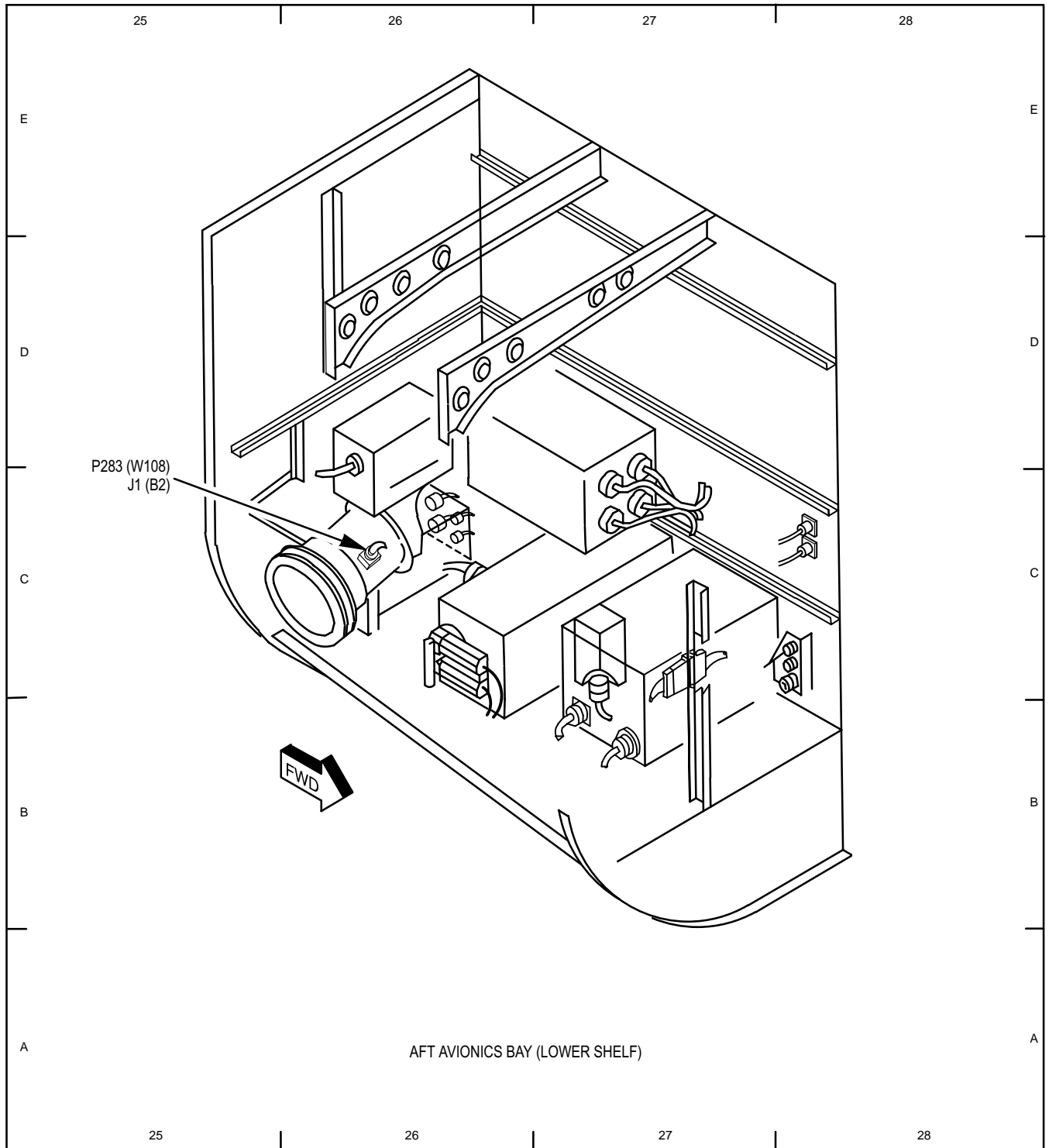

M71-288

SECTION III. TROUBLESHOOTING PROCEDURES

13-10. ENVIRONMENTAL CONTROL SYSTEM - POWER UP

13-10

**Tools:**

<u>Nomenclature</u>	<u>Part Number</u>
Tool Kit, Aircraft Mechanic's	SC518099CLA01

**Equipment Conditions:**

<u>Ref</u>	<u>Condition</u>
TM 55-1520-238-23	Helicopter safed External power application - Electrical - Pressurized Air Environmental control system inspection completed

**Personnel Required:**

67R Attack Helicopter Repairer  
One person to assist

**References:**

TM 55-1520-238-23

**NOTE**

Refer to pilot station (fig. 13-12) and CPG station (fig. 13-13) for cockpit configuration and equipment.

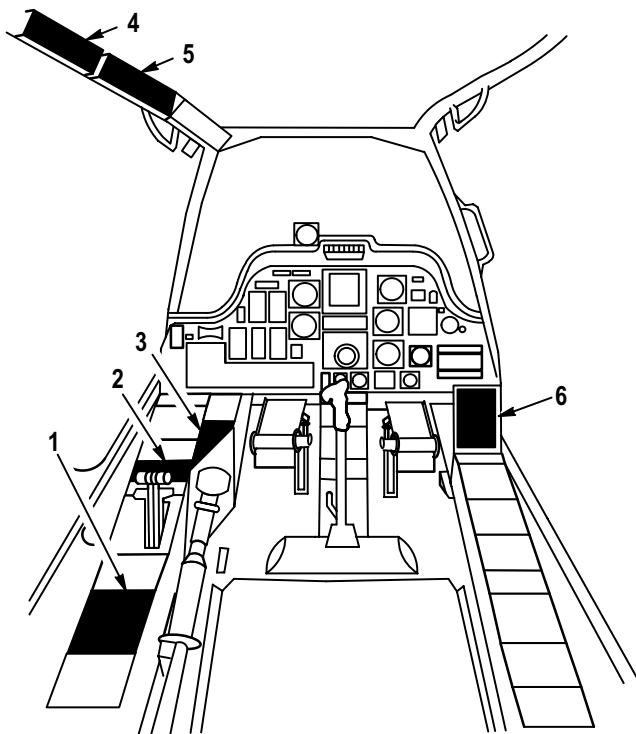

1. PILOT EXT LT/INTR LT PANEL
2. PILOT ELEC PWR PANEL
3. PILOT ECS PANEL
4. PILOT AFT CIRCUIT BREAKER PANEL
5. PILOT CENTER CIRCUIT BREAKER PANEL
6. PILOT CAUTION / WARNING PANEL

**Figure 13-12. Pilot Station**

M71-153

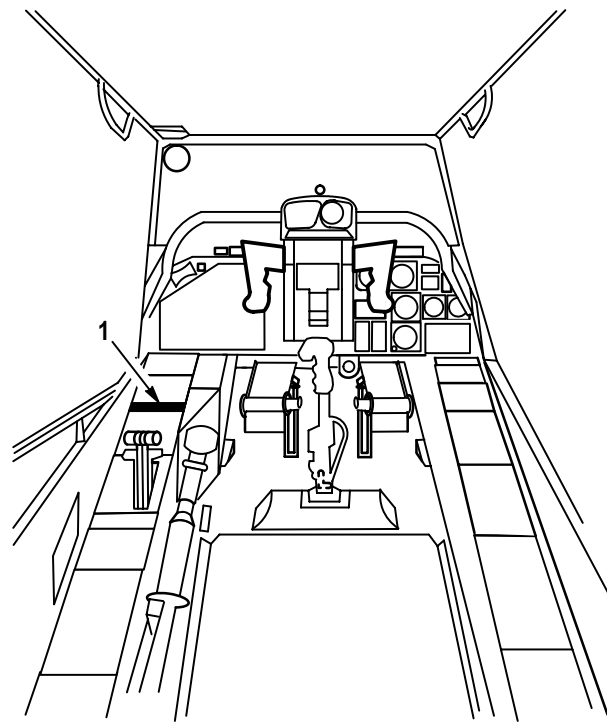

1. CPG AUX / ANTI - ICE PANEL

**Figure 13-13. CPG Station**

M71-154

13-10. ENVIRONMENTAL CONTROL SYSTEM - POWER UP (cont)

13-10

1. On pilot **ELEC PWR** panel (fig. 13-14), set **BATT/EXT PWR** switch to **EXT PWR**.

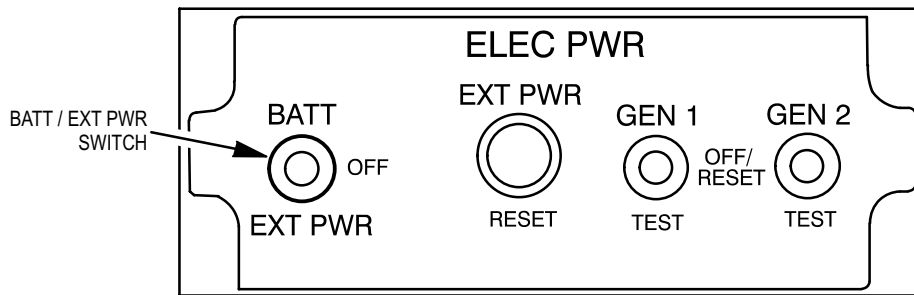

M71-155

Figure 13-14. Pilot ELEC PWR Panel

2. On pilot circuit breaker panels (fig. 13-15), check that the following circuit breakers are closed:

<u>Circuit Breaker Panel</u>	<u>Circuit Breaker</u>	<u>Circuit Breaker Panel</u>	<u>Circuit Breaker</u>
Aft	<b>ECS FAB FANS</b>	Center	<b>LT CAUT</b>
Aft	<b>ECS CAB</b>	Center	<b>LT PRI</b>
Aft	<b>ECS AFT FAN</b>		

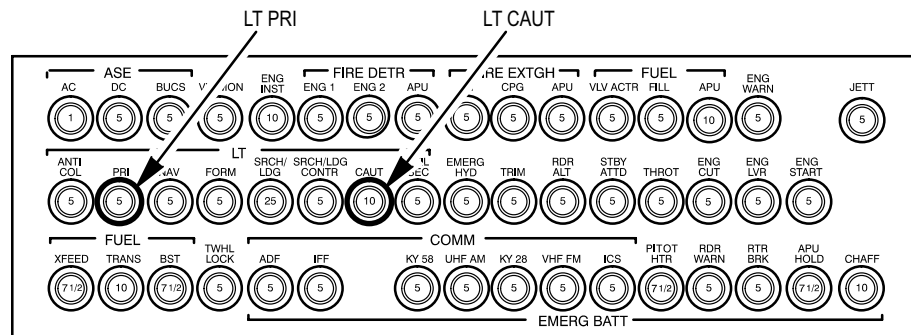

CENTER

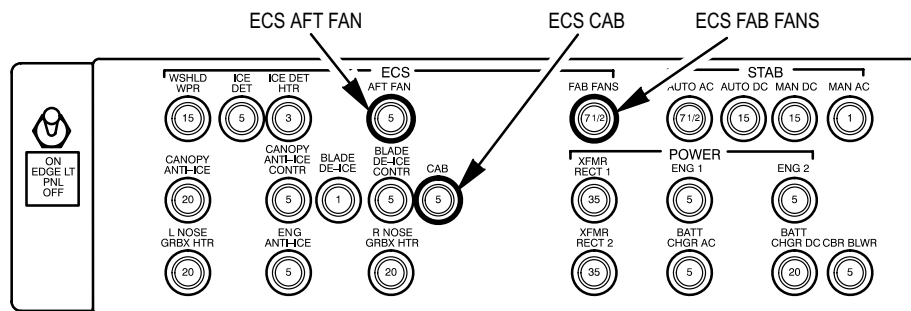

AFT

M71-156

Figure 13-15. Pilot Circuit Breaker Panels

13-10. ENVIRONMENTAL CONTROL SYSTEM - POWER UP (cont)

13-10

3. On pilot **ECS** panel (fig. 13-16), set switches/controls as follows:

<u>Switch/Control</u>	<u>Position</u>
<b>ENCU</b>	<b>ON</b>
<b>STBY FAN</b>	<b>NORM</b>
<b>TEMP</b>	As desired

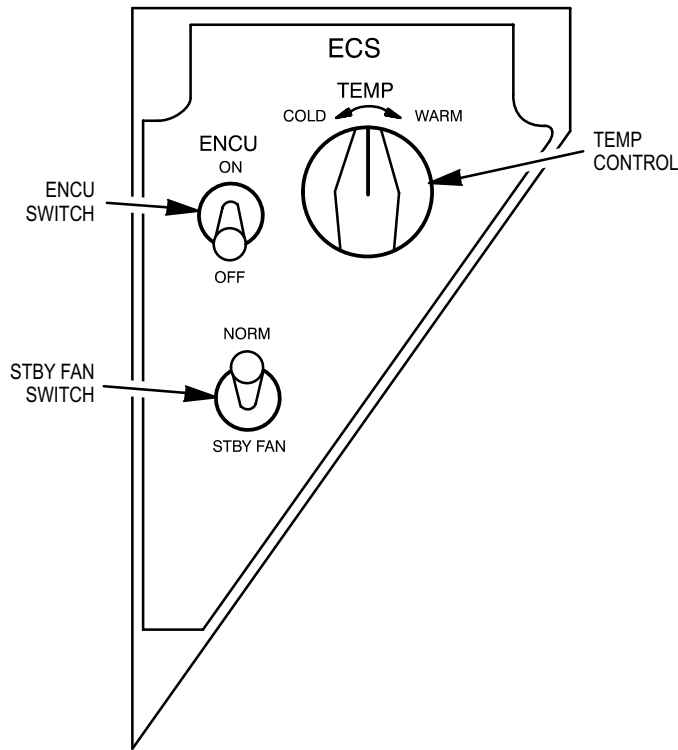

M71-157

Figure 13-16. Pilot ECS Panel

4. On pilot **EXT LT/INTR LT** panel (fig. 13-17), set **L CSL** to **BRT**.

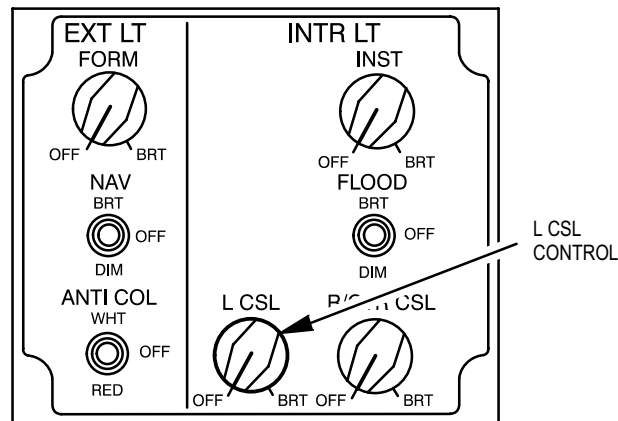

M71-158

Figure 13-17. Pilot EXT LT/INTR LT Panel

13-10. ENVIRONMENTAL CONTROL SYSTEM - POWER UP (cont)

13-10

- On CPG **AUX/ANTI-ICE** panel (fig. 13-18), set **STBY FAN** switch to **OFF**.

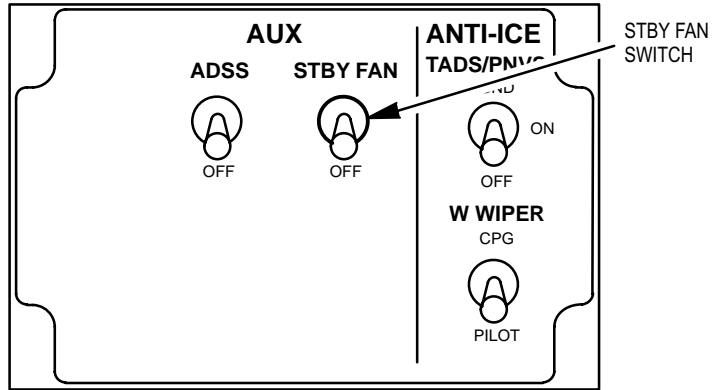

M71-159

Figure 13-18. CPG AUX/ANTI-ICE Panel

END OF TASK

13-1 1. ENVIRONMENTAL CONTROL SYSTEM - POWER DOWN

13-1 1

**Tools:**

Nomenclature

Tool Kit, Aircraft  
Mechanic's

Part Number

SC518099CLA01

**References:**

TM 55-1520-238-23

**Equipment Conditions:**

Ref

Paragraph 13-10

Condition

ENVIRONMENTAL  
CONTROL SYSTEM -  
POWER UP completed

**Personnel Required:**

67R Attack Helicopter Repairer  
One person to assist

**NOTE**

Refer to pilot station (fig. 13-12) and CPG station (fig. 13-13) for cockpit configuration and equipment.

1. On pilot **EXT LT/INTR LT** panel (fig. 13-17), set **L CSL** to **OFF**.
2. On pilot **ECS** panel (fig. 13-16), set switches/controls as follows.

Switch/Control

**ENCU**

**STBY FAN**

Position

**ON**

**NORM**

3. On pilot circuit breaker panels (fig. 13-15), open the following circuit breakers.

Circuit

Breaker Panel

Aft

Aft

Aft

Circuit Breaker

**ECS FAB FANS**

**ECS CAB**

**ECS AFT FAN**

Circuit

Breaker Panel

Center

Center

Circuit Breaker

**LT PRI**

**LT CAUT**

4. On CPG **AUX/ANTI-ICE** panel (fig. 13-18), set **STBY FAN** switch to **OFF**.
5. On pilot **ELEC PWR** panel (fig. 13-14), set **BATT/EXT PWR** switch to **OFF**.
6. Remove external power - electrical and pressurized air (TM 55-1520-238-23).

END OF TASK

**13-12. ENVIRONMENTAL CONTROL SYSTEM - MAINTENANCE OPERATIONAL CHECK**

**13-12**

**Tools:**

<u>Nomenclature</u>	<u>Part Number</u>
Tool Kit, Aircraft Mechanic's	SC518099CLA01
Tool Kit, Electrical Repairer's	SC518099CLA06

**References:**

TM 1-1520-238-T-4  
TM 1-1520-238-23

**Equipment Conditions:**

<u>Ref</u>	<u>Condition</u>
Paragraph 13-10	ENVIRONMENTAL CONTROL SYSTEM - POWER UP completed
TM 1-1520-238-T-4	Maintenance headset connected

**Personnel Required:**

67R Attack Helicopter Repairer  
68X Armament/Electrical Systems Repairer

**WARNING**

Make sure that helicopter safing procedures are accomplished. Observe all safety precautions during troubleshooting or maintenance procedures. Failure to do so could result in death or serious injury.

**CAUTION**

- Operate the ECS to maintain required cooling of units during ground maintenance to prevent damage to equipment.
- If an avionics component is removed (without plugging air supply slots), flow to other components may be degraded sufficiently to cause damage.

**NOTE**

- Refer to pilot station (fig. 13-12) and CPG station (fig. 13-13) for cockpit configuration and equipment.
- If referenced out of one paragraph or volume into another for additional troubleshooting, upon completion of the task, return to the maintenance operational check for the original paragraph or volume.
- If crew members are at a comfortable temperature, avionics equipment is at normal operating temperature.
- Do not use left engine bleed air; it is not practical for ground maintenance.
- Above 80° F (27° C) ambient temperature, observe the following rules:
  - ENCU is to be supplied with air from the shaft driven compressor (SDC) or from a ground support vehicle.
  - The FAB fans are to be operating in normal mode.
- At any ambient temperature, the following fans are to be operating:
  - Aft avionics bay fan.
  - TADS/PNVS turret fan.
  - FAB fans.
- Canopy is to be closed at 80° F (27° C) ambient temperature and above.
- Aft doors are to be closed, FAB doors may be open.

1. Complete the maintenance operational check as follows:

Task	Result
a. On pilot aft circuit breaker panel (fig. 13-15), check that <b>ECS FAB FANS</b> circuit breaker stays closed.	If <b>ECS FAB FANS</b> circuit breaker does not stay closed, go to paragraph 13-14.
b. On pilot aft circuit breaker panel, check that <b>ECS CAB</b> circuit breaker stays closed.	If <b>ECS CAB</b> circuit breaker does not stay closed, go to paragraph 13-15.
c. On pilot aft circuit breaker panel, check that <b>ECS AFT FAN</b> circuit breaker stays closed.	If <b>ECS AFT FAN</b> circuit breaker does not stay closed, go to paragraph 13-16.
d. On pilot <b>ECS</b> panel (fig. 13-16), set <b>ENCU</b> switch to <b>OFF</b> and then to <b>ON</b> again. Check for proper airflow.	If there is no or low air flow, go to paragraph 13-18.



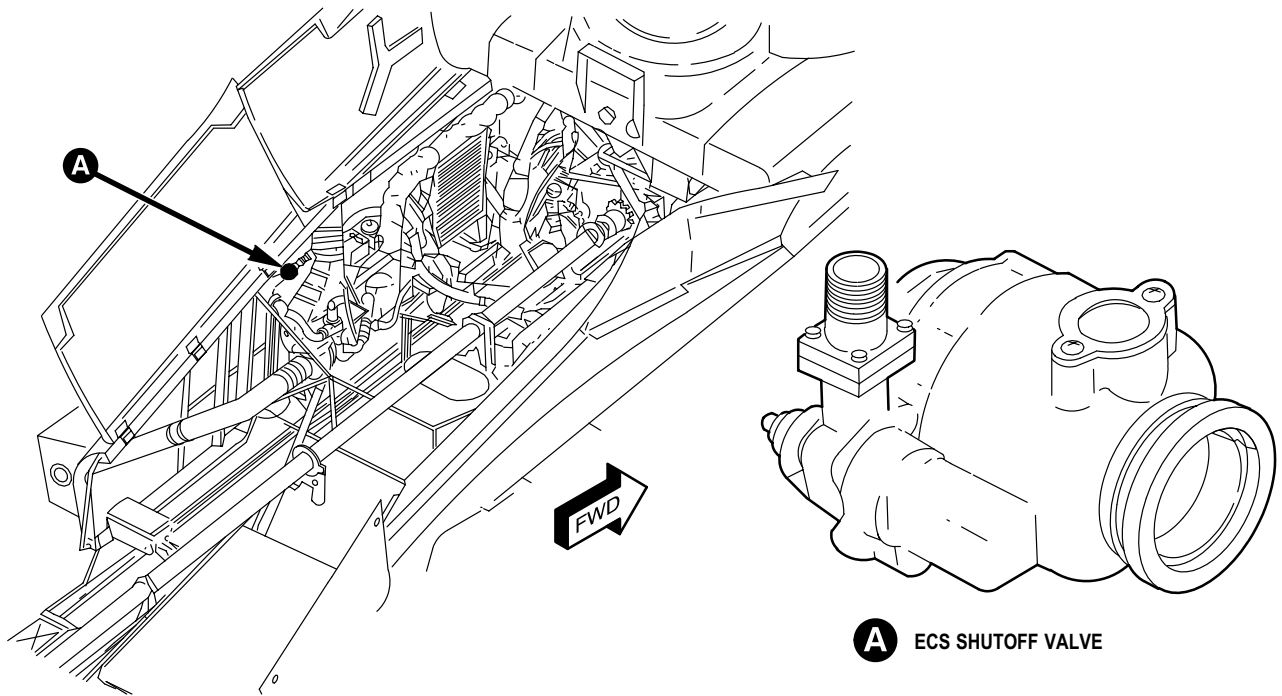

M71-160

Figure 13-19. ECS Shutoff Valve

**NOTE**

The ECS caution/warning indicator will light at  $105^{\circ} \pm 3^{\circ} \text{ F}$  ( $41^{\circ} \pm 2^{\circ} \text{ C}$ ) and go out at  $95^{\circ} \pm 3^{\circ} \text{ F}$  ( $35 \pm 2^{\circ} \text{ C}$ ). The ECS indicator should not light at normal operating range temperatures of  $80^{\circ}$  to  $89^{\circ} \text{ F}$  ( $27^{\circ}$  to  $32^{\circ} \text{ C}$ ).

Task	Result
e. On pilot caution/warning panel (fig. 13-20), check <b>ECS</b> indicator.	If <b>ECS</b> indicator lights, go to paragraph 13-20.  If <b>ECS</b> indicator did not light, in a known overheat condition, go to paragraph 13-21.

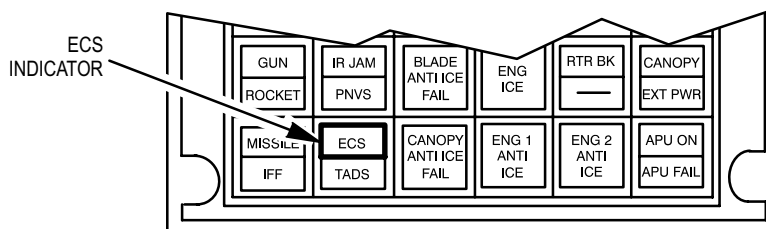

M71-161

Figure 13-20. Pilot Caution/Warning Panel

**13-12. ENVIRONMENTAL CONTROL SYSTEM - MAINTENANCE OPERATIONAL CHECK (cont) 13-12**

Task	Result
f. On pilot <b>ECS</b> panel (fig. 13-16), check panel edge-light.	If <b>ECS</b> panel edge-light does not light, go to paragraph 13-17.
g. On pilot <b>ECS</b> panel, rotate <b>TEMP</b> control to <b>COLD</b> , then to <b>WARM</b> .	If there is no or low air flow, go to paragraph 13-18. If there is no temperature change or if moisture level is too high, go to paragraph 13-19.
h. Check aft avionics bay fan overboard exhaust (fig. 13-21).	If aft avionics bay fan is not operating, go to paragraph 13-22.
i. Check electrical power distribution box fan (fig. 13-21).	If electrical power distribution box fan is not operating, replace fan (TM 1-1520-238-23).
j. Check left and right FAB fans (fig. 13-21).	If left FAB normal fan is not operating, go to paragraph 13-23.
	If right FAB normal fan is not operating, go to paragraph 13-24.
	If both FAB normal fans are not operating, go to paragraph 13-25.
k. On pilot <b>ECS</b> panel, set <b>STBY FAN</b> switch to <b>STBY FAN</b> .	

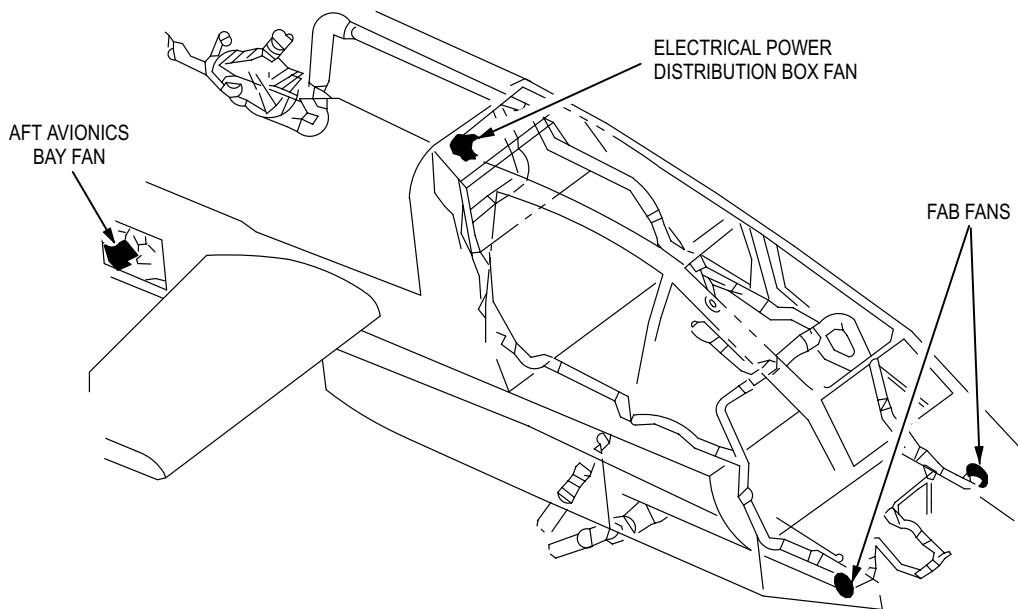

M71-162

**Figure 13-21. ECS Fans**

---

**13-12. ENVIRONMENTAL CONTROL SYSTEM - MAINTENANCE OPERATIONAL CHECK (cont) 13-12**

---

Task	Result
l. On pilot aft circuit breaker panel (fig. 13-15), check that <b>ECS FAB FANS</b> circuit breaker stays closed.	If <b>ECS FAB FANS</b> circuit breaker does not stay closed, go to paragraph 13-26.
m. On pilot aft circuit breaker panel, check that <b>ECS CAB</b> circuit breaker stays closed.	If <b>ECS CAB</b> circuit breaker does not stay closed, go to paragraph 13-15.
n. Check left and right FAB fans (fig. 13-21) for increased air flow.	If left FAB standby fan is not operating, replace left FAB vaneaxial fan (TM 1-1520-238-23).  If right FAB standby fan is not operating, replace right FAB vaneaxial fan (TM 1-1520-238-23).  If both FAB standby fans are not operating, go to paragraph 13-27.
o. On pilot <b>ECS</b> panel (fig. 13-16), set <b>STBY FAN</b> switch to <b>NORM</b> .	
p. On CPG <b>AUX/ANTI-ICE</b> panel (fig. 13-18), set <b>STBY FAN</b> switch to <b>STBY FAN</b> .	
q. On pilot aft circuit breaker panel (fig. 13-15), check that <b>ECS FAB FANS</b> circuit breaker stays closed.	If <b>ECS FAB FANS</b> circuit breaker does not stay closed, go to paragraph 13-14.
r. On pilot aft circuit breaker panel, check that <b>ECS CAB</b> circuit breaker stays closed.	If <b>ECS CAB</b> circuit breaker does not stay closed, go to paragraph 13-15.
s. Check left and right FAB fans (fig. 13-21).	If right FAB standby fan is not operating, replace right FAB vaneaxial fan (TM 1-1520-238-23).  If left FAB standby fan is not operating, replace left FAB vaneaxial fan (TM 1-1520-238-23).  If both FAB standby fans are not operating, go to paragraph 13-28.

- 
2. Perform ENVIRONMENTAL CONTROL SYSTEM - POWER DOWN (para 13-11).
  3. Disconnect maintenance headset (TM 1-1520-238-T-4).

END OF TASK

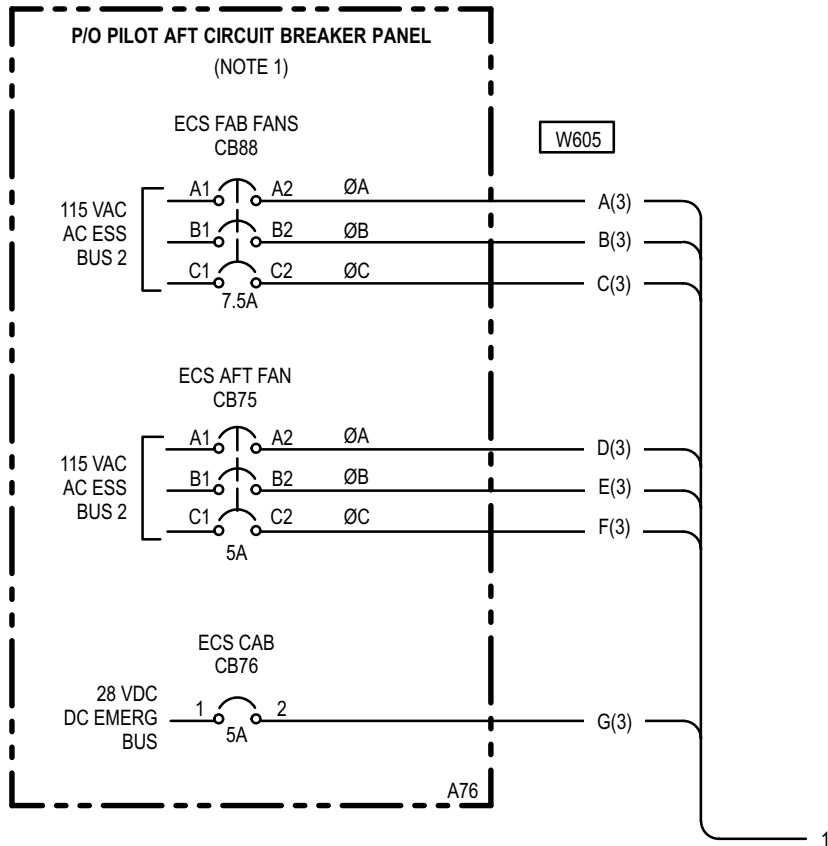

13-13. ENVIRONMENTAL CONTROL SYSTEM - WIRING INTERCONNECT DIAGRAM (cont)

13-13

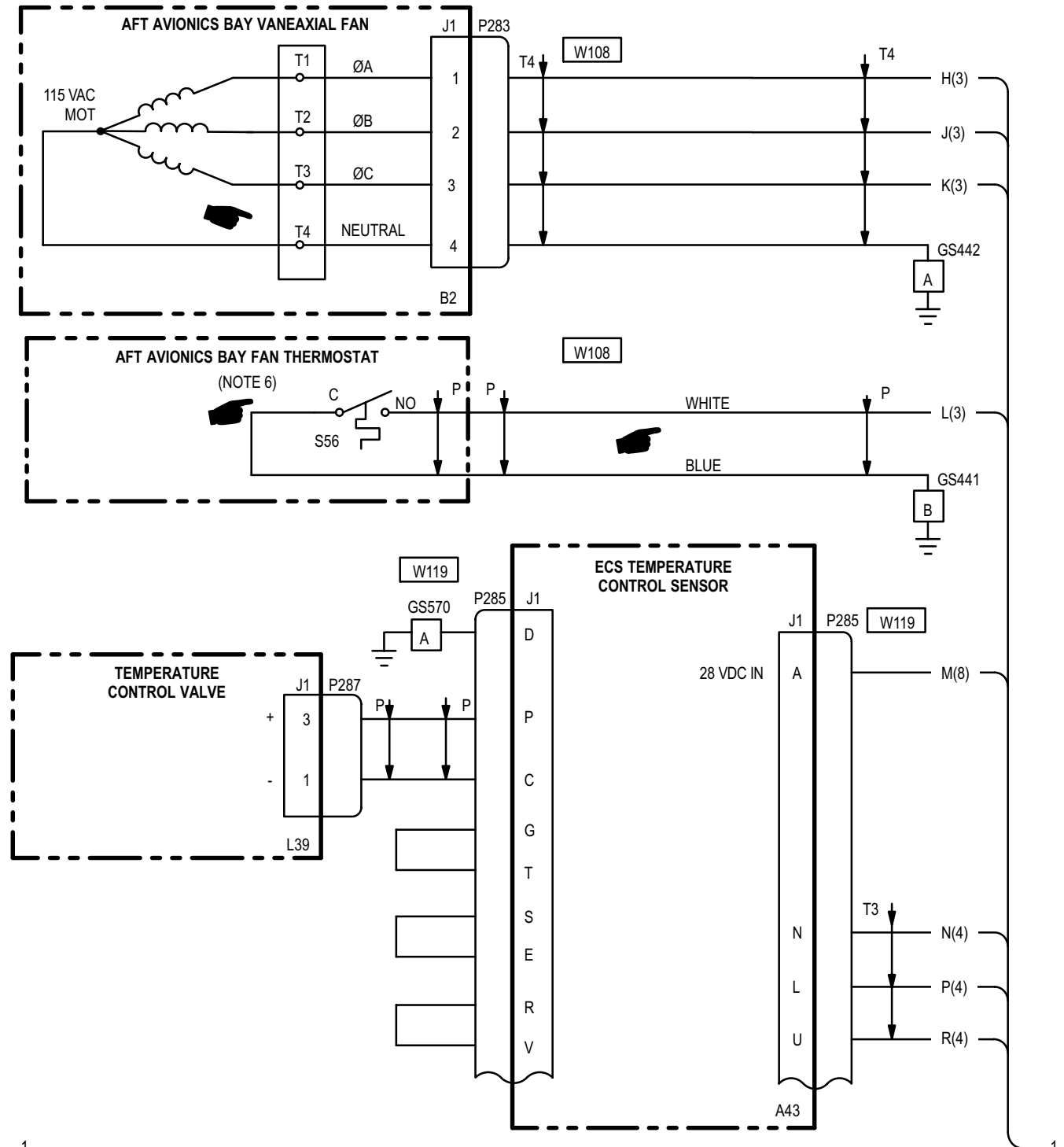

1

1

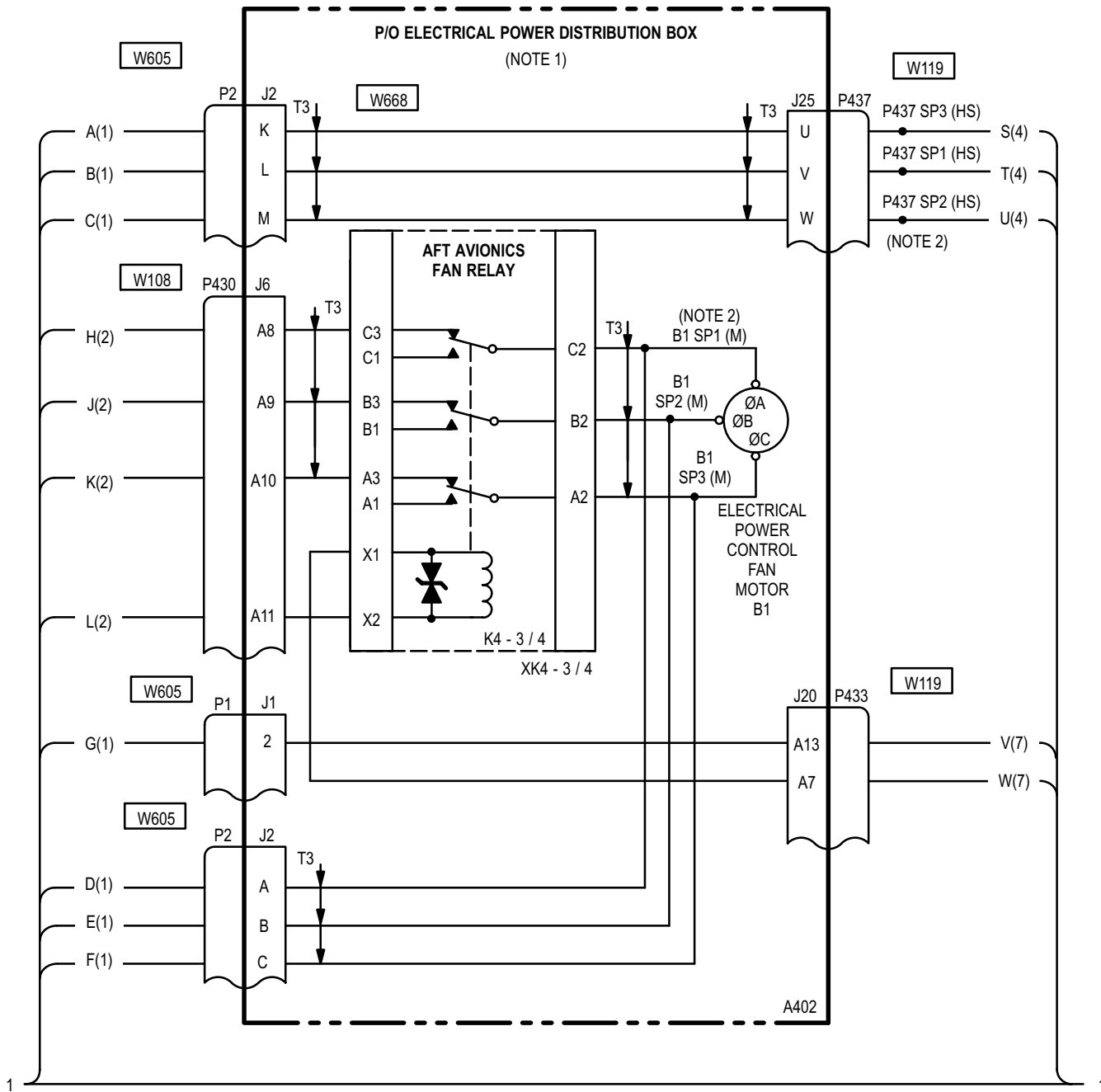

13-13. ENVIRONMENTAL CONTROL SYSTEM - WIRING INTERCONNECT DIAGRAM (cont)

13-13

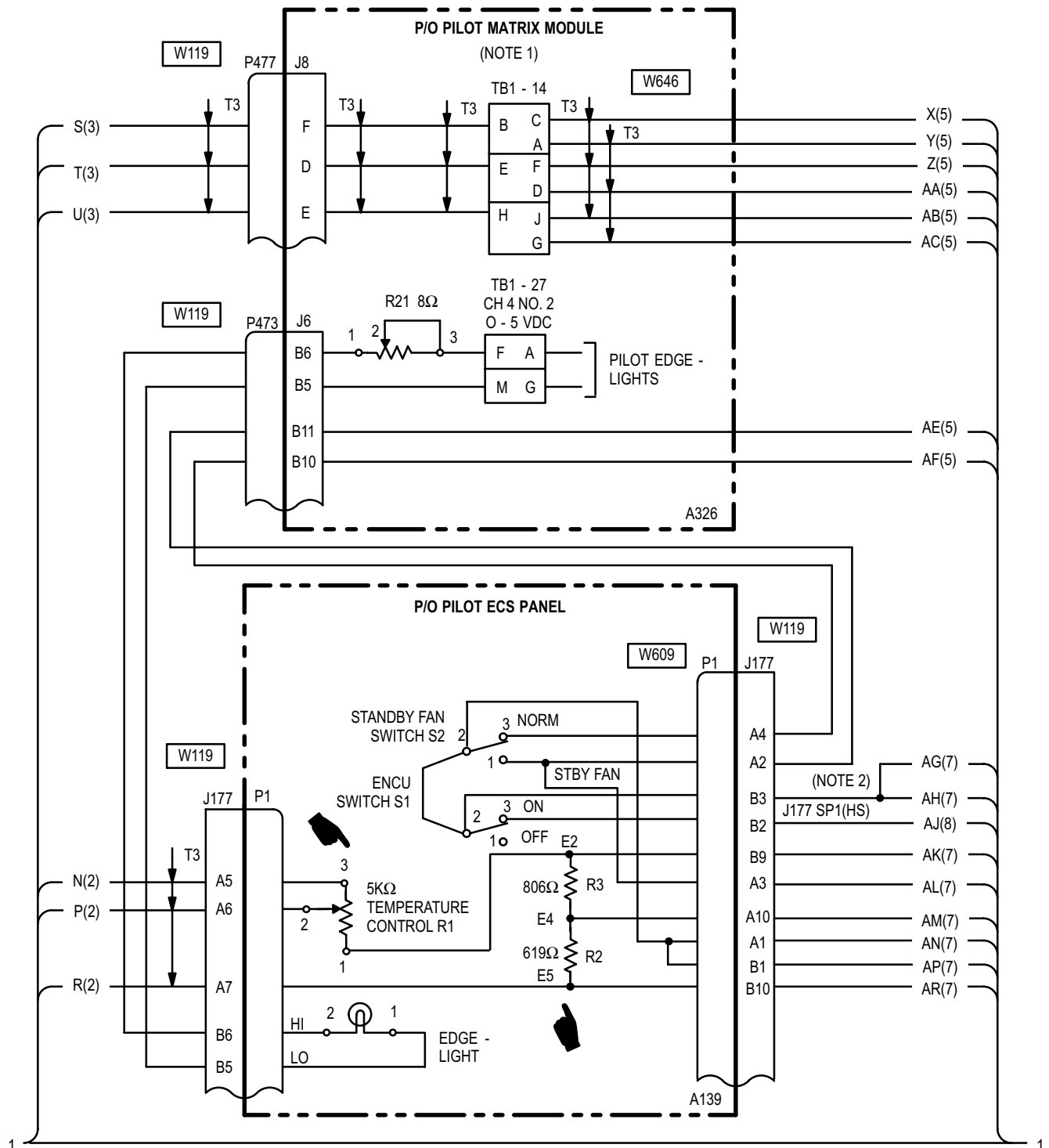

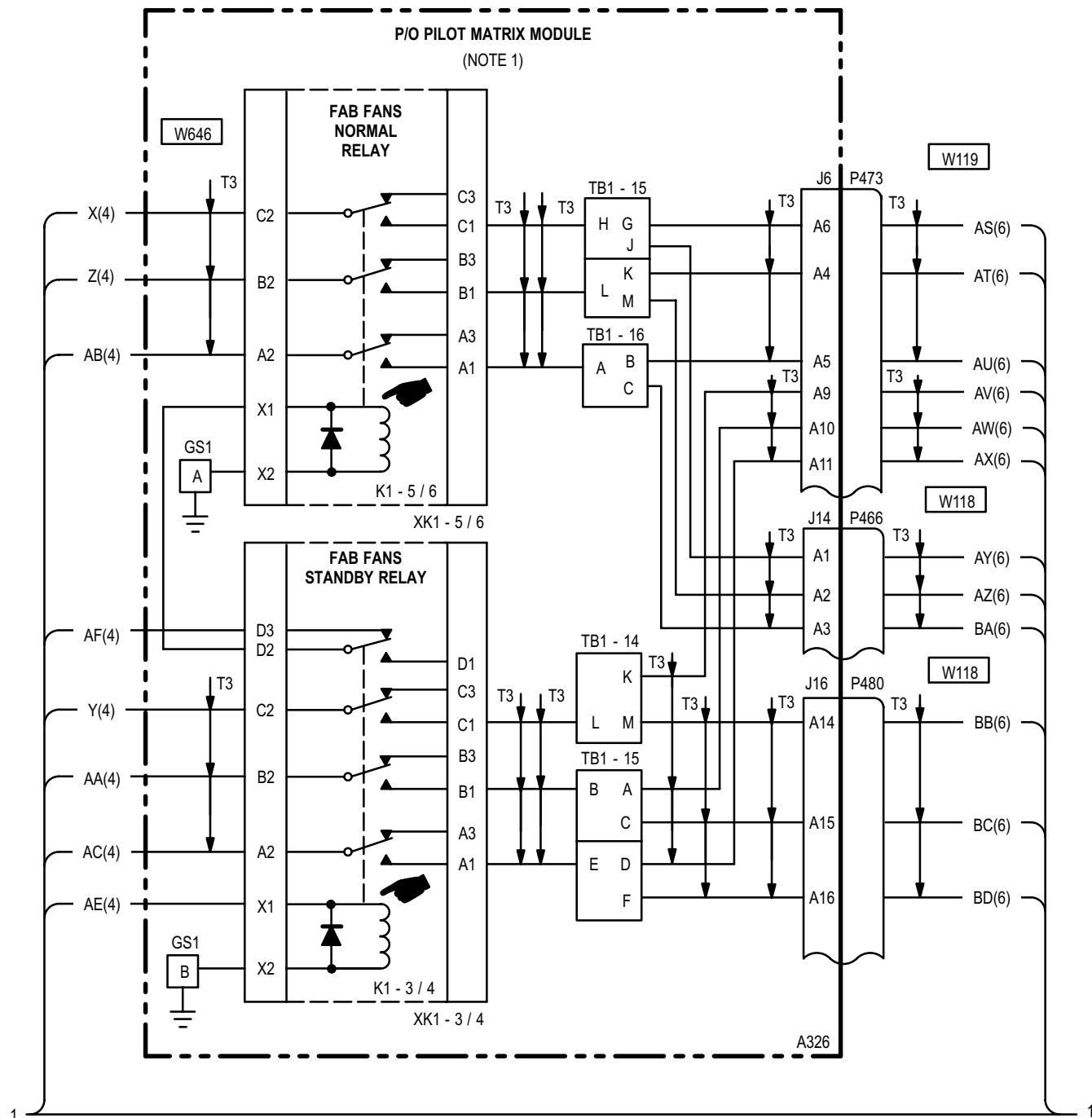



13-13. ENVIRONMENTAL CONTROL SYSTEM - WIRING INTERCONNECT DIAGRAM (cont)

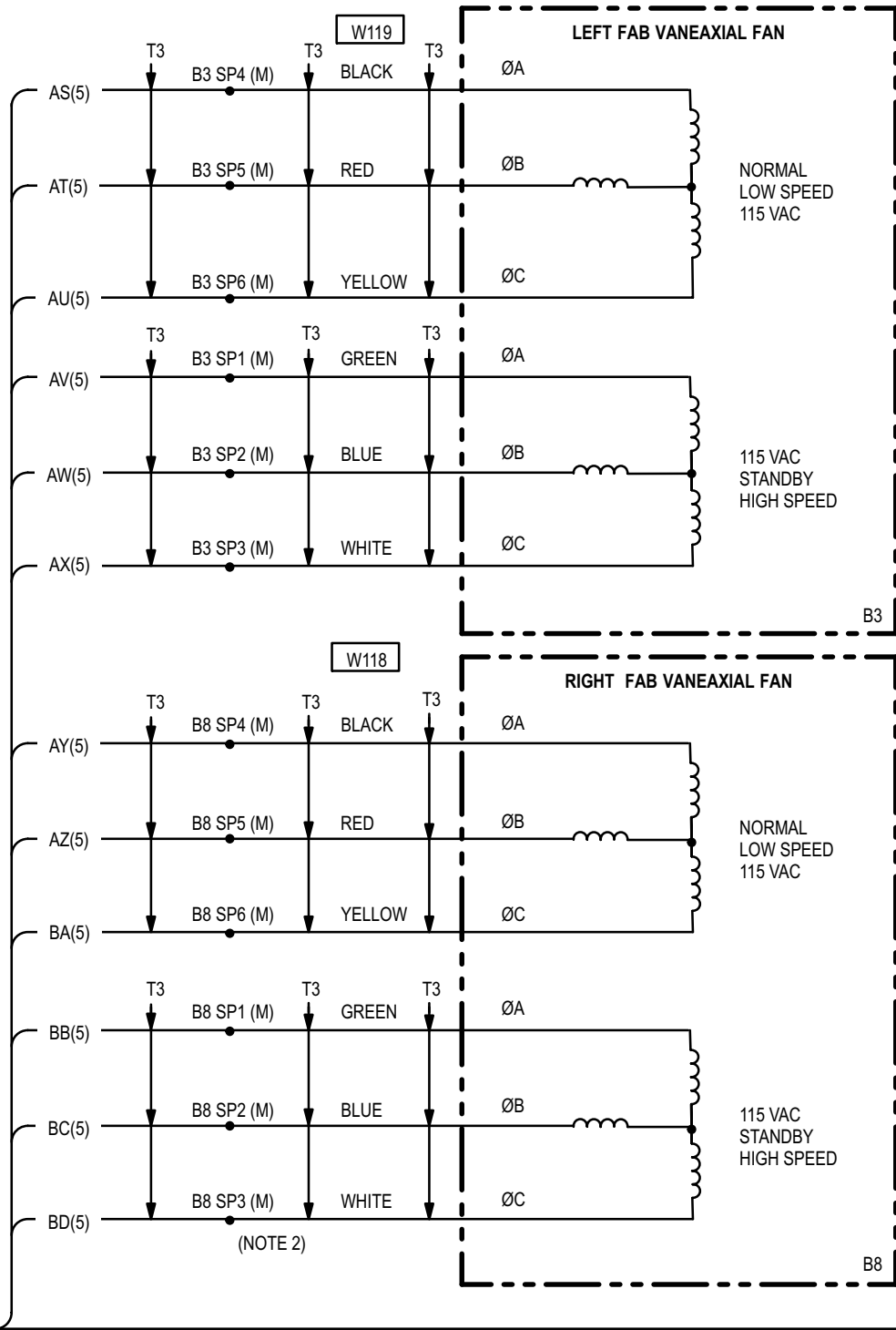

1

1

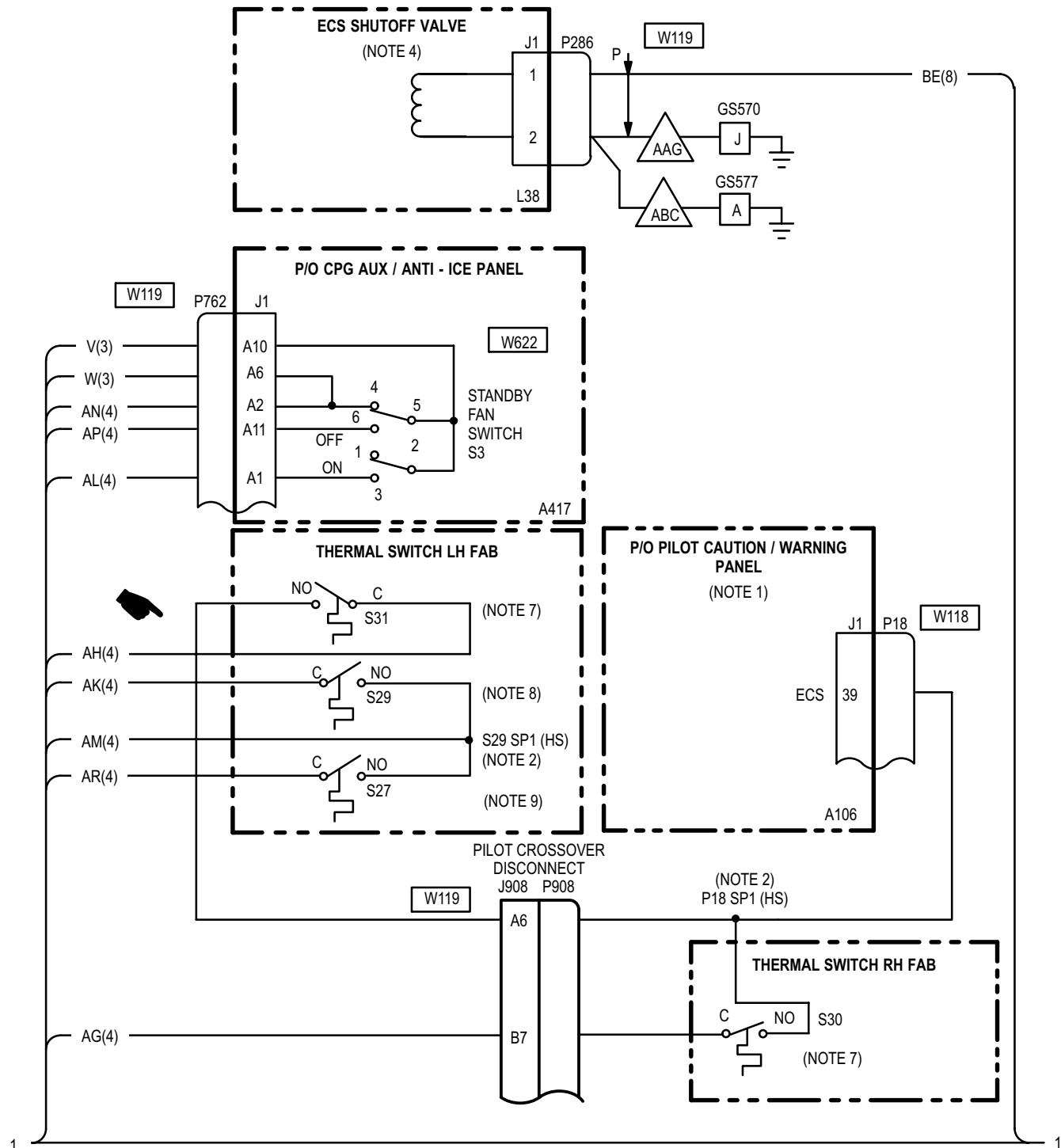

13-13. ENVIRONMENTAL CONTROL SYSTEM - WIRING INTERCONNECT DIAGRAM (cont)

13-13

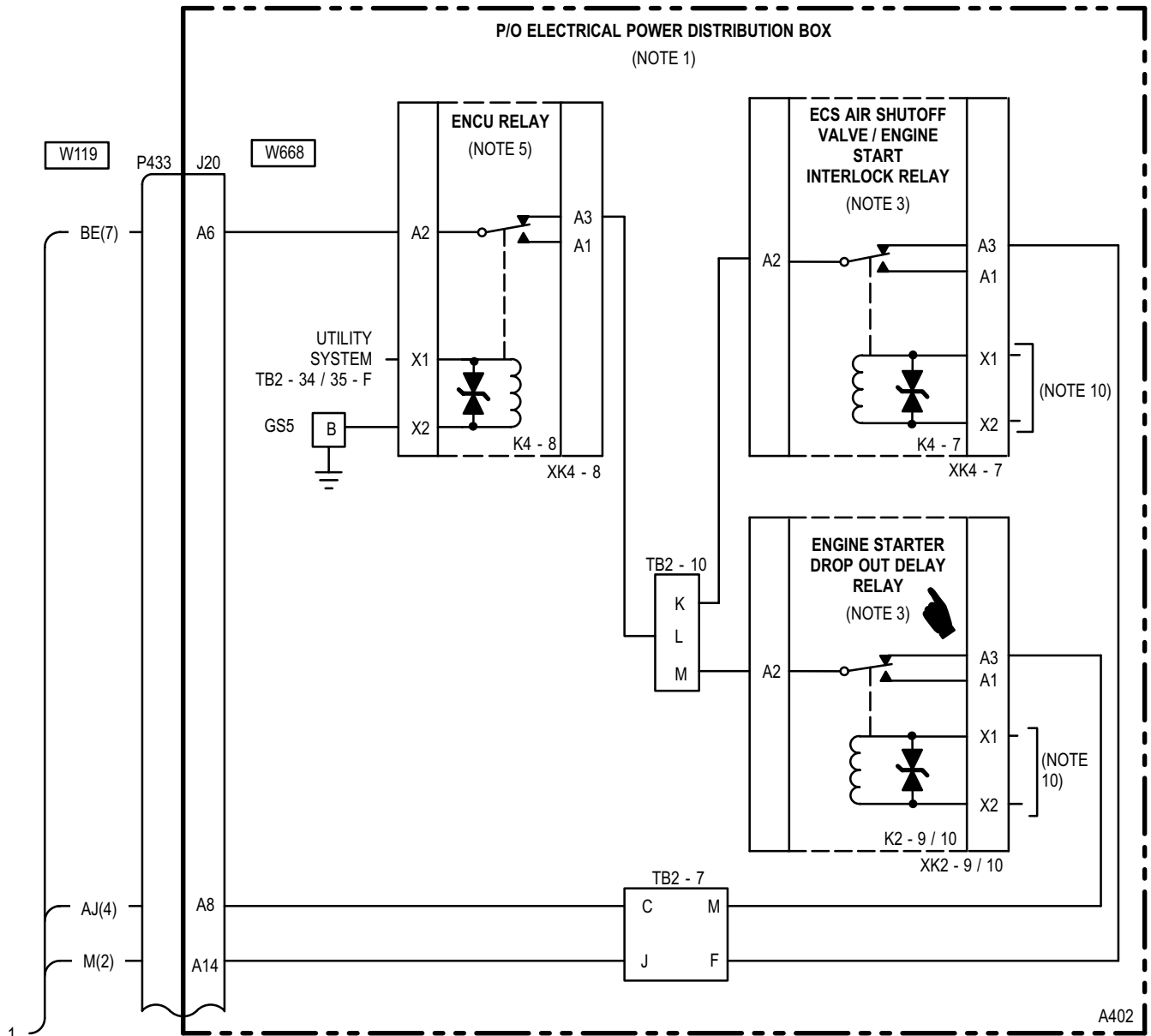

NOTES:

HIGHWAY USE: THE ALPHA CHARACTER IDENTIFIES A SPECIFIC LINE, AND THE NUMBER IN PARENTHESIS IDENTIFIES THE SHEET NUMBER WHERE THE SIGNAL TERMINATES.

- |  |  |
|--|--|
| <p>1. ELECTRICAL SYSTEM (TM 1-1520-238-T-6).</p> <p>2. HS DESIGNATES A HARD SPLICE WHICH CANNOT BE DISCONNECTED, M DESIGNATES A SOFT SPLICE WHICH MAY BE DISCONNECTED FOR A WIRING CHECK.</p> <p>3. RELAYS ENERGIZED DURING ENGINE STARTING.</p> <p>4. 28 VDC OPENS VALVE.</p> | <p>5. RELAY ENERGIZED WHEN FIRE PULL HANDLES ARE PULLED.</p> <p>6. CLOSES AT <math>0^{\circ} \pm 10^{\circ} F</math> (<math>-18^{\circ} \pm 6^{\circ} C</math>). OPENS AT <math>25^{\circ} \pm 10^{\circ} F</math> (<math>-4^{\circ} \pm 6^{\circ} C</math>).</p> <p>7. CLOSES AT <math>105^{\circ} \pm 3^{\circ} F</math> (<math>41^{\circ} \pm 2^{\circ} C</math>). OPENS AT <math>95^{\circ} \pm 3^{\circ} F</math> (<math>35^{\circ} \pm 2^{\circ} C</math>).</p> <p>8. OPENS AT <math>85^{\circ} \pm 3^{\circ} F</math> (<math>29^{\circ} \pm 2^{\circ} C</math>). CLOSES AT <math>75^{\circ} \pm 3^{\circ} F</math> (<math>24^{\circ} \pm 2^{\circ} C</math>).</p> <p>9. OPENS AT <math>75^{\circ} \pm 3^{\circ} F</math> (<math>24^{\circ} \pm 2^{\circ} C</math>). CLOSES AT <math>65^{\circ} \pm 3^{\circ} F</math> (<math>18^{\circ} \pm 2^{\circ} C</math>).</p> <p>10. POWER PLANTS (TM 1-1520-238-T-4).</p> |
|--|--|

M71-242-8B  
SHEET 8 OF 8

13-14. ECS FAB FANS CIRCUIT BREAKER (CB88) - DOES NOT STAY CLOSED

13-14

**Tools:**

<u>Nomenclature</u>	<u>Part Number</u>
Tool Kit, Electrical Repairer's	SC518099CLA06
Extractor, Relay	CTJ-RO6
Multimeter, Digital	AN/PSM-45

**Personnel Required:**

68X Armament/Electrical Systems Repairer

**References:**

TM 1-1520-238-T-6  
 TM 55-1520-238-23

**Equipment Conditions:**

<u>Ref</u>	<u>Condition</u>
TM 55-1520-238-23	Non-transparent barrier removed



**Turn off power before detaching or attaching wires and connectors. High current 28 VDC or 115 VAC is present. Failure to do so could result in death or serious injury.**

1. Detach P477. Check for short between (A402): J2-K and ground, J2-L and ground, J2-M and ground.

**Does short exist?**

- YES      Go to step 2.
- NO        Go to step 3.

2. Detach P477. Check for short between: P437-U and ground, P437-V and ground, P437-W and ground.

**Does short exist?**

- YES      Repair shorted wire between: P437-U and P477-F, P437-V and P477-D, P437-W and P477-E. Go to paragraph 13-12.
- NO        Repair shorted wire between (A402): J2-K and J25-U, J2-L and J25-V, J2-M and J25-W. Go to paragraph 13-12.

3. With P477 attached, check for short between: (A402): J2-K and ground, J2-L and ground, J2-M and ground.

**Does short exist?**

- YES      Go to step 4.
- NO        Go to step 6.

4. With relay (A326)K1-5/6 removed, check for short between (A402): J2-K and ground, J2-L and ground, J2-M and ground.

**Does short exist?**

- YES      Go to step 5.
- NO        Replace relay (A326)K1-5/6 (TM 55-1520-238-23).

**13-14. ECS FAB FANS CIRCUIT BREAKER (CB88) - DOES NOT STAY CLOSED (cont)**

**13-14**

5. With relay (A326)K1-3/4 removed, check for short between (A402):  
J2-K and ground,  
J2-L and ground,  
J2-M and ground.

**Does short exist?**

YES Repair shorted wire between (A326):  
TB1-14-A and XK1-3/4-C2,  
TB1-14-B and J8-F,  
TB1-14-C and XK1-5/6-C2,  
TB1-14-D and XK1-3/4-B2,  
TB1-14-E and J8-D,  
TB1-14-F and XK1-5/6-B2,  
TB1-14-G and XK1-3/4-A2,  
TB1-14-H and J8-E,  
TB1-14-J and XK1-5/6-A2.  
Go to paragraph 13-12.

NO Replace relay (A326)K1-3/4 (TM 55-1520-238-23).

6. With relay (A326)K1-5/6 removed, check for short between (A326):  
XK1-5/6-A1 and ground,  
XK1-5/6-B1 and ground,  
XK1-5/6-C1 and ground.

**Does short exist?**

YES Go to step 12.

NO Go to step 7.

7. With relay (A326)K1-3/4 removed, check for short between (A326):  
XK1-3/4-A1 and ground,  
XK1-3/4-B1 and ground,  
XK1-3/4-C1 and ground.

**Does short exist?**

YES Go to step 10.

NO Go to step 8.

8. Check for short between (A326):  
K1-3/4-A1 and relay case ground,  
K1-3/4-B1 and relay case ground,  
K1-3/4-C1 and relay case ground.

**Does short exist?**

YES Replace relay (A326)K1-3/4 (TM 55-1520-238-23).

NO Go to step 9.

9. Check for short between (A326):  
K1-5/6-A1 and relay case ground,  
K1-5/6-B1 and relay case ground,  
K1-5/6-C1 and relay case ground.

**Does short exist?**

YES Replace relay (A326)K1-5/6 (TM 55-1520-238-23).

NO Refer to TM 1-1520-238-T-6 to troubleshoot circuit protection system (ac essential bus 2 - pilot station).

10. Detach P480. Check for short between (A326):  
XK1-3/4-A1 and XK1-3/4-B1,  
XK1-3/4-A1 and XK1-3/4-C1,  
XK1-3/4-B1 and XK1-3/4-C1.

**Does short exist?**

YES Go to step 11.

NO Replace right FAB vaneaxial fan (B8) (TM 55-1520-238-23).

**13-14. ECS FAB FANS CIRCUIT BREAKER (CB88) - DOES NOT STAY CLOSED (cont)**

**13-14**

11. Detach P466. Check for short between (A326):  
 XK1-3/4-A1 and XK1-3/4-B1,  
 XK1-3/4-A1 and XK1-3/4-C1,  
 XK1-3/4-B1 and XK1-3/4-C1.

**Does short exist?**

YES Repair shorted wire between (A326):  
 TB1-14-K and J6-A9,  
 TB1-14-L and XK1-3/4-C1,  
 TB1-14-M and J16-A14,  
 TB1-15-A and J6-A10,  
 TB1-15-B and XK 1-3/4-B1,  
 TB1-15-C and J16-A15,  
 TB1-15-D and J6-A11,  
 TB1-15-E and XK1-3/4-A1  
 TB1-15-F and J16-A16.  
 Go to paragraph 13-12.

NO Replace right FAB vaneaxial fan (TM 55-1520-238-23).

12. Detach P466. With relay (A326)K1-5/6 removed, check for short between (A326): XK1-5/6-A1 and ground,  
 XK1-5/6-B1 and ground,  
 XK1-5/6-C1 and ground.

**Does short exist?**

YES Go to step 13.

NO Replace right FAB vaneaxial fan (B8) (TM 55-1520-238-23).

13. Detach P473. Check for short between (A326):  
 XK1-5/6-A1 and XK1-5/6-B1,  
 XK1-5/6-A1 and XK1-5/6-C1,  
 XK1-5/6-B1 and XK1-5/6-C1.

**Does short exist?**

YES Repair shorted wire between (A326):  
 TB1-16-A and XK1-5/6-A1,  
 TB1-16-B and J6-A5,  
 TB1-16-C and J14-A3,  
 TB1-15-G and J6-A6,  
 TB1-15-H and XK1-5/6-C1,  
 TB1-15-J and J14-A1,  
 TB1-15-K and J6-A4  
 TB1-15-L and XK1-5/6-B1,  
 TB1-15-M and J14-A2.  
 Go to paragraph 13-12.

NO Replace left FAB vaneaxial fan (B3) (TM 55-1520-238-23).

END OF TASK

**13-15. ECS CAB CIRCUIT BREAKER (CB76) - DOES NOT STAY CLOSED**

**13-15**

**Tools:**

<u>Nomenclature</u>	<u>Part Number</u>
Tool Kit, Electrical Repairer's	SC518099CLA06
Multimeter, Digital	AN/PSM-45

**Personnel Required:**

68X Armament/Electrical Systems Repairer

**References:**

TM 1-1520-238-T-6  
 TM 55-1520-238-23



**Turn off power before detaching or attaching wires and connectors. High current 28 VDC or 115 VAC is present. Failure to do so could result in death or serious injury.**

1. Check for short between J177-B3 and ground.  
**Does short exist?**

YES	Repair shorted wire between: J177-B3 and S31-C, J177-B3 and J908-B7, P908-B7 and S30-C. Go to paragraph 13-12.
NO	Go to step 2.

2. Check for short between J177-A4 and ground.  
**Does short exist?**

YES	Go to step 9.
NO	Go to step 3.

3. Detach P762. Check for short between: J177-A1 and ground, J177-B1 and ground.  
**Does short exist?**

YES	Go to step 4.
NO	Replace pilot <b>ECS</b> panel (TM 55-1520-238-23).

4. Check for short between: P762-A2 and ground, P762-A11 and ground.  
**Does short exist?**

YES	Repair shorted wire between: J177-A1 and P762-A2, J177-B1 and P762-A11. Go to paragraph 13-12.
NO	Go to step 5.

5. Detach P433. Check for short between: P762-A6 and ground, P762-A10 and ground.  
**Does short exist?**

YES	Repair shorted wire between: P762-A6 and P433-A7, P762-A10 and P433-A13. Go to paragraph 13-12.
NO	Go to step 6.

6. Check for short between (A402)J20-A7 and ground.  
**Does short exist?**

YES	Go to step 7.
NO	Go to step 8.

7. Detach wire from (A402)XK4-3/4-X1. Check for short between (A402)J20-A7 and ground.  
**Does short exist?**

YES	Repair shorted wire. Go to paragraph 13-12.
NO	Replace aft avionics fan relay (A402)K4-3/4 (TM 55-1520-238-23).

8. Detach P1. Check for short between (A402)J20-A13 and ground.  
**Does short exist?**

YES	Repair shorted wire. Go to paragraph 13-12.
NO	Refer to TM 1-1520-238-T-6 to troubleshoot circuit protection system (dc emergency bus - pilot station).

---

**13-15. ECS CAB CIRCUIT BREAKER (CB76) - DOES NOT STAY CLOSED (cont)**

---

**13-15**

9. Detach wire from (A326)XK1-3/4-D2. Check for short between (A326)XK1-3/4-D2 and ground.

**Does short exist?**

YES        Go to step 11.

NO         Go to step 10.

10. Detach wire from (A326)XK1-5/6-X1. Check for short between wire end removed from (A326)XK1-5/6-X1 and ground.

**Does short exist?**

YES        Repair shorted wire.  
Go to paragraph 13-12.

NO         Replace FAB fans normal relay  
(A326)K1-5/6  
(TM 55-1520-238-23).

11. Detach wire from (A326)XK1-3/4-D3. Check for short between J177-A4 and ground.

**Does short exist?**

YES        Repair shorted wire.  
Go to paragraph 13-12.

NO         Replace FAB fans standby relay  
(A326)K1-3/4  
(TM 55-1520-238-23).

END OF TASK



**13-16. ECS AFT FAN CIRCUIT BREAKER (CB75) - DOES NOT STAY CLOSED**

**13-16**

**Tools:**

<u>Nomenclature</u>	<u>Part Number</u>
Tool Kit, Electrical Repairer's	SC518099CLA06
Extractor, Relay	CTJ-RO6
Multimeter, Digital	AN/PSM-45

**Personnel Required:**

68X Armament/Electrical Systems Repairer

**References:**

TM 1-1520-238-T-6  
 TM 55-1520-238-23



**Turn off power before detaching or attaching wires and connectors. High current 28 VDC or 115 VAC is present. Failure to do so could result in death or serious injury.**

1. Open **ECS AFT FAN** circuit breaker (CB75).  
 Check for short between (A402):  
 J2-A and ground,  
 J2-B and ground,  
 J2-C and ground.

**Does short exist?**

- |     |  |
|-----|--|
| YES | Go to step 2.  |
| NO  | Refer to TM 1-1520-238-T-6 to troubleshoot circuit protection system (ac essential bus 2 - pilot station). |

2. Check for short between:  
 P430-A8 and ground,  
 P430-A9 and ground,  
 P430-A10 and ground.

**Does short exist?**

- |     |               |
|-----|---------------|
| YES | Go to step 6. |
| NO  | Go to step 3. |

3. Detach electrical power distribution box fan wires at (A402):  
 B1 SP1,  
 B1 SP2,  
 B1 SP3.  
 Check for short between (A402):  
 J2-A and ground,  
 J2-B and ground,  
 J2-C and ground.

**Does short exist?**

- |     |  |
|-----|--|
| YES | Go to step 4.  |
| NO  | Replace electrical distribution box fan (TM 55-1520-238-23). |

4. Remove relay (A402)K4-3/4. Check for short between (A402):  
 J6-A8 and ground,  
 J6-A9 and ground,  
 J6-A10 and ground.

**Does short exist?**

- |     |   |
|-----|---|
| YES | Repair shorted wire between (A402):<br>J6-A8 and XK4-3/4-C3,<br>J6-A9 and XK4-3/4-B3,<br>J6-A10 and XK4-3/4-A3.<br>Go to paragraph 13-12. |
| NO  | Go to step 5.   |

5. With (A402)K4-3/4 relay removed, check for short between (A402):  
 J2-A and ground,  
 J2-B and ground,  
 J2-C and ground.

**Does short exist?**

- |     |   |
|-----|---|
| YES | Repair shorted wire between (A402):<br>J2-A and B1 SP1,<br>J2-B and B1 SP2,<br>J2-C and B1 SP3,<br>XK4-3/4-A2 and B1 SP3,<br>XK4-3/4-B2 and B1 SP2,<br>XK4-3/4-C2 and B1 SP1.<br>Go to paragraph 13-12. |
| NO  | Replace relay (A402)K4-3/4 (TM 55-1520-238-23).   |

---

13-16. ECS AFT FAN CIRCUIT BREAKER (CB75) - DOES NOT STAY CLOSED (cont)

---

13-16

6. Detach P283. Check for short between:

- P430-A8 and ground,
- P430-A9 and ground,
- P430-A10 and ground.

**Does short exist?**

- |     |  |
|-----|--|
| YES | Repair shorted wire between:<br>P430-A8 and P283-1,<br>P430-A9 and P283-2,<br>P430-A10 and P283-3.<br>Go to paragraph 13-12. |
| NO  | Replace aft avionics bay<br>vaneaxial fan (B2)<br>(TM 55-1520-238-23).   |

END OF TASK

**13-17. ECS PANEL EDGE-LIGHT - DOES NOT LIGHT****13-17****Tools:**

<u>Nomenclature</u>	<u>Part Number</u>
Tool Kit, Electrical Repairer's	SC518099CLA06
Multimeter, Digital	AN/PSM-45

**Personnel Required:**

68X Armament/Electrical Systems Repairer  
One person to assist

**References:**

TM 1-1520-238-23

<b>WARNING</b>
----------------

**Turn off power before detaching or attaching wires and connectors. High current 28 VDC or 115 VAC is present. Failure to do so could result in death or serious injury.**

1. On pilot **EXT LT/INTR LT** panel, adjust **L CSL** control to **BRT**. Check for 5 VDC at J177-B6 with **LT PRI** circuit breaker (CB39) closed.  
**Is voltage present?**

YES	Go to step 2.
NO	Repair open wire between: J177-B6 and P473-B6. (A326)J6-B6 and (A326)TB1-27-F. Go to paragraph 13-12.

2. Check for open between:  
J177-B5 and P473-B5.  
(A326)J6-B5 and (A326)TB1-27-M.  
**Does open exist?**

YES	Repair open wire. Go to paragraph 13-12.
NO	Replace pilot <b>ECS</b> panel (TM 1-1520-238-23).

END OF TASK

**13-18. ECS SHUTOFF VALVE DOES NOT OPERATE - CREW STATIONS  
RECEIVE NO OR LOW AIRFLOW**

**Tools:**

<u>Nomenclature</u>	<u>Part Number</u>
Tool Kit, Electrical Repairer's	SC518099CLA06
Extractor, Relay	CTJ-RO6
Multimeter, Digital	AN/PSM-45

**Personnel Required:**

68X Armament/Electrical Systems Repairer  
One person to assist

**References:**

TM 1-1520-238-T-6  
TM 1-1520-238-23



**Turn off power before detaching or attaching wires and connectors. High current 28 VDC or 115 VAC is present. Failure to do so could result in death or serious injury.**

- Check indicator on ECS shutoff valve for completely open position.  
**Is open indicated?**  

YES	Go to step 2.
NO	Go to step 4.
- Check ENCU for cooling turbine binding or rubbing against scroll, excessive vibration, abnormal noise or cracks (leakage) from case.  
**Is ENCU defective?**  

YES	Replace ENCU (TM 1-1520-238-23).
NO	Go to step 3.

- Check air ducts between crew stations and ENCU for air leakage.  
**Is air leaking?**  

YES	Repair or replace ducts or cuffs as necessary (TM 1-1520-238-23).
NO	Replace ENCU (TM 1-1520-238-23).
- Check for 28 VDC at J177-A1.  
**Is voltage present?**  

YES	Go to step 8.
NO	Go to step 5.
- Check for 28 VDC at P762-A10.  
**Is voltage present?**  

YES	Go to step 7.
NO	Go to step 6.
- Check for 28 VDC at P1-2.  
**Is voltage present?**  

YES	Repair wire between (A402)J1-2 and P762-A10. Go to paragraph 13-12.
NO	Refer to TM 1-1520-238-T-6 to troubleshoot circuit protection system (dc emergency bus - pilot station).
- Check continuity between (A417): J1-A10 and J1-A2.  
**Does continuity exist?**  

YES	Repair open wire between P762-A2 and J177-A1. Go to paragraph 13-12.
NO	Replace CPG <b>AUX/ANTI-ICE</b> panel (TM 1-1520-238-23).

**13-18. ECS SHUTOFF VALVE DOES NOT OPERATE - CREW STATIONS  
RECEIVE NO OR LOW AIRFLOW (cont)**

**13-18**

8. With **ENCU** switch set to **ON**, check for open between P1-A1 and P1-B2.

**Does open exist?**

YES      Replace **ECS** panel  
(TM 1-1520-238-23).

NO        Go to step 9.

9. Check for 28 VDC at (A402)TB2-7-C.

**Is voltage present?**

YES      Go to step 10.

NO        Repair open wire between  
(A402)TB2-7-C and J177-B2.  
Go to paragraph 13-12.

10. Check for 28 VDC at P286-1.

**Is voltage present?**

YES      Go to step 14.

NO        Go to step 11.

11. Remove relay (A402)K4-8. Check for open between (A402)K4-8-A2 and (A402)K4-8-A3.

**Does open exist?**

YES      Replace relay (A402)K4-8  
(TM 1-1520-238-23).

NO        Go to step 12.

12. Remove squat relay (A402)K4-7. Check for open between (A402)K4-8-A2 and (A402)K4-8-A3.

**Does open exist?**

YES      Replace relay (A402)K4-7  
(TM 1-1520-238-23).

NO        Go to step 13.

13. Check for open between:  
P286-1 and P433-A6.  
(A402)J20-A6 and (A402)XK4-8-A2,  
(A402)XK4-8-A3 and (A402)TB2-10-L.

**Does open exist?**

YES      Repair open wire.  
Go to paragraph 13-12.

NO        Replace (A402)TB2-10 and  
(A402)TB2-7  
(TM 1-1520-238-23).

14. Check for open between:

**(AAG)**P286-2 and GS570-J.

**(ABC)**P286-2 and GS577-A.

**Does open exist?**

YES      Repair open wire or replace  
ground module.  
Go to paragraph 13-12.

NO        Replace ECS shutoff valve  
(TM 1-1520-238-23).

END OF TASK

**13-19. CREW STATION TEMPERATURE - DOES NOT VARY OR MOISTURE LEVEL IS TOO HIGH**

**13-19**

**Tools:**

<u>Nomenclature</u>	<u>Part Number</u>
Tool Kit, Electrical Repairer's	SC518099CLA06
Multimeter, Digital	AN/PSM-45

**Personnel Required:**

68X Armament/Electrical Systems Repairer  
One person to assist

**References:**

TM 1-1520-238-23



**Turn off power before detaching or attaching wires and connectors. High current 28 VDC or 115 VAC is present. Failure to do so could result in death or serious injury.**

1. On pilot **ECS** panel, adjust **TEMP** control.  
**Is temperature level adjustable?**

YES	Go to step 9.
NO	Go to step 2.
  
2. While rotating **ECS** panel **TEMP** control from **COLD** to **WARM**, check for variable resistance between (A139):  
P1-A6 and P1-A5,  
P1-A6 and P1-A7.  
**Does resistance vary with TEMP control movement?**

YES	Go to step 3.
NO	Replace pilot <b>ECS</b> panel (TM 1-1520-238-23).

3. On pilot aft circuit breaker panel, close **ECS CAB** circuit breaker (CB76), set **ENCU** switch on pilot **ECS** panel to **ON**. Check for 28 VDC at P285-A.  
**Is voltage present?**

YES	Go to step 4.
NO	Repair open wire between: P285-A and P433-A14. (A402): J20-A14 and TB2-7-J. Go to paragraph 13-12.
  
4. Check for open between P285-D and ground.  
**Does open exist?**

YES	Repair open wire between P285-D and GS570-A. Go to paragraph 13-12.
NO	Go to step 5.
  
5. Check for open between: P285-C and P287-1, P285-P and P287-3.  
**Does open exist?**

YES	Repair open wire. Go to paragraph 13-12.
NO	Go to step 6.
  
6. Check for open between (L39): J1-1 and J1-3.  
**Does open exist?**

YES	Replace temperature control valve (TM 1-1520-238-23).
NO	Go to step 7.
  
7. Check for open between: P285-N and J177-A5, P285-L and J177-A6, P285-U and J177-A7.  
**Does open exist?**

YES	Repair open wire. Go to paragraph 13-12.
NO	Go to step 8.

---

**13-19. CREW STATION TEMPERATURE - DOES NOT VARY  
OR MOISTURE LEVEL IS TOO HIGH (cont)**

---

13-19

8. On ECS temp control sensor, check for open between (A43):  
J1-P and J1-N,  
J1-C and J1-U.

**Does open exist?**

YES        Replace ECS temp control  
                 sensor (TM 55-1520-238-23).

NO         Replace ENCU  
                 (TM 55-1520-238-23).

9. Check ENCU water hoses for blockage.

**Does blockage exist?**

YES        Perform ENCU cleaning (water  
                 wash) (TM 55-1520-238-23).

NO         Replace ENCU  
                 (TM 55-1520-238-23).

END OF TASK

---

**13-20. ECS CAUTION/WARNING INDICATOR - LIGHTS**

---

13-20

**Tools:**

<u>Nomenclature</u>	<u>Part Number</u>
Tool Kit, Electrical Repairer's	SC518099CLA06
Multimeter, Digital	AN/PSM-45

**Personnel Required:**

68X Armament/Electrical Systems Repairer  
One person to assist

**References:**

TM 55-1520-238-23

---

<b>WARNING</b>
----------------

**Turn off power before detaching or attaching wires and connectors. High current 28 VDC or 115 VAC is present. Failure to do so could result in death or serious injury.**

Check for 28 VDC at J908-A6.

**Is voltage present?**

YES	Replace left FAB thermal switch S31 (TM 55-1520-238-23).
NO	Replace right FAB thermal switch S30 (TM 55-1520-238-23).

END OF TASK



**13-21. ECS INDICATOR - DID NOT LIGHT IN KNOWN OVERHEAT CONDITION**

**13-21**

**Tools:**

<u>Nomenclature</u>	<u>Part Number</u>
Tool Kit, Electrical Repairer's	SC518099CLA06
Multimeter, Digital	AN/PSM-45

**Personnel Required:**

68X Armament/Electrical Systems Repairer  
One person to assist

**References:**

TM 1-1520-238-23

3. Check for open between:  
P18-39 and P18 SP1,  
P18 SP1 and S30-NO,  
P18 SP1 and P908-A6,  
P908-A6 and S31-NO.  
**Does open exist?**

YES	Repair open wire. Go to paragraph 13-12.
NO	Replace thermal switches S30 and S31 (TM 1-1520-238-23).



**Turn off power before detaching or attaching wires and connectors. High current 28 VDC or 115 VAC is present. Failure to do so could result in death or serious injury.**

1. Check for 28 VDC at S30-C.  
**Is voltage present?**

YES	Go to step 2.
NO	Repair open wire between: J177-B3 and J177 SP1, J177 SP1 and J908-B7 P908-B7 and S30-C. (A139)S11-2 and P1-B3. Go to paragraph 13-12.
  
2. Check for 28 VDC at S31-C.  
**Is voltage present?**

YES	Go to step 3.
NO	Repair open wire between J177 SP1 and S31-C. Go to paragraph 13-12.

END OF TASK

13-22. AFT AVIONICS BAY FAN - DOES NOT OPERATE

13-22

**Tools:**

<u>Nomenclature</u>	<u>Part Number</u>
Tool Kit, Electrical Repairer's	SC518099CLA06
Extractor, Relay	CTJ-RO6
Multimeter, Digital	AN/PSM-45

**Personnel Required:**

68X Armament/Electrical Systems Repairer  
One person to assist

**References:**

TM 1-1520-238-T-6  
TM 1-1520-238-23

**WARNING**

**Turn off power before detaching or attaching wires and connectors. High current 28 VDC or 115 VAC is present. Failure to do so could result in death or serious injury.**

1. Check for 115 VAC at:  
P2-A,  
P2-B,  
P2-C.

**Is voltage present?**

- |     |  |
|-----|--|
| YES | Go to step 2.  |
| NO  | Refer to TM 1-1520-238-T-6 to troubleshoot circuit protection system (ac essential bus 2 - pilot station). |

2. Check for 115 VAC between:  
P283-1 and P283-4,  
P283-2 and P283-4,  
P283-3 and P283-4.

**Is voltage present?**

- |     |   |
|-----|---|
| YES | Replace aft avionics bay vaneaxial fan (B2) (TM 1-1520-238-23). |
| NO  | Go to step 3.   |

3. Check for open between P283-4 and GS442.  
**Does open exist?**

- |     |   |
|-----|---|
| YES | Repair open wire.<br>Go to paragraph 13-12. |
| NO  | Go to step 4.                               |

4. Check for short between (A402)XK4-3/4-X2 and ground.

**Does short exist?**

- |     |  |
|-----|--|
| YES | Go to step 5.                                  |
| NO  | Replace relay (A402)K4-3/4 (TM 1-1520-238-23). |

5. With switch (S56) removed, check for short between (A402)XK4-3/4-X2 and ground.

**Does short exist?**

- |     |  |
|-----|--|
| YES | Repair shorted wire.<br>Go to paragraph 13-12. |
| NO  | Replace switch (S56) (TM 1-1520-238-23).       |

END OF TASK

---

**13-23. LEFT FAB NORMAL FAN - DOES NOT OPERATE**

---

13-23

**Tools:**

<u>Nomenclature</u>	<u>Part Number</u>
Tool Kit, Electrical Repairer's	SC518099CLA06
Multimeter, Digital	AN/PSM-45

**Personnel Required:**

68X Armament/Electrical Systems Repairer

**References:**

TM 55-1520-238-23

**Equipment Conditions:**

<u>Ref</u>	<u>Condition</u>
TM 55-1520-238-23	Non-transparent barrier removed

---

**WARNING**

**Turn off power before detaching or attaching wires and connectors. High current 28 VDC or 115 VAC is present. Failure to do so could result in death or serious injury.**

Check for open between:

P473-A6 and B3 SP4,  
P473-A4 and B3 SP5,  
P473-A5 and B3 SP6.

(A326):

TB1-15-G and J6-A6,  
TB1-15-K and J6-A4,  
TB1-16-B and J6-A5.

**Does open exist?**

- |     |  |
|-----|--|
| YES | Repair open wire.<br>Go to paragraph 13-12.              |
| NO  | Replace left FAB vaneaxial fan (B3) (TM 55-1520-238-23). |

END OF TASK

---

**13-24. RIGHT FAB NORMAL FAN - DOES NOT OPERATE**

---

13-24

**Tools:**

<u>Nomenclature</u>	<u>Part Number</u>
Tool Kit, Electrical Repairer's	SC518099CLA06
Multimeter, Digital	AN/PSM-45

**Personnel Required:**

68X Armament/Electrical Systems Repairer

**References:**

TM 55-1520-238-23

**Equipment Conditions:**

<u>Ref</u>	<u>Condition</u>
TM 55-1520-238-23	Non-transparent barrier removed

---

<b>WARNING</b>
----------------

**Turn off power before detaching or attaching wires and connectors. High current 28 VDC or 115 VAC is present. Failure to do so could result in death or serious injury.**

Check for open between:

P466-A1 and B8 SP4,  
P466-A2 and B8 SP5,  
P466-A3 and B8 SP6.

(A326):

TB1-15-J and J14-A1,  
TB1-15-M and J14-A2,  
TB1-16-C and J14-A3,

**Does open exist?**

YES	Repair open wire. Go to paragraph 13-12.
NO	Replace right FAB vaneaxial fan (B3) (TM 55-1520-238-23).

END OF TASK

**13-25. BOTH FAB NORMAL FANS - DO NOT OPERATE**

**13-25**

**Tools:**

<u>Nomenclature</u>	<u>Part Number</u>
Tool Kit, Electrical Repairer's	SC518099CLA06
Multimeter, Digital	AN/PSM-45

**Personnel Required:**

68X Armament/Electrical Systems Repairer  
One person to assist

**References:**

TM 1-1520-238-T-6  
TM 55-1520-238-23



**Turn off power before detaching or attaching wires and connectors. High current 28 VDC or 115 VAC is present. Failure to do so could result in death or serious injury.**

1. Check for 115 VAC at:  
P2-K,  
P2-L,  
P2-M.

**Are 3 phases of voltage present?**

- |     |  |
|-----|--|
| YES | Go to step 2.  |
| NO  | Refer to TM 1-1520-238-T-6 to troubleshoot circuit protection system (ac essential bus 2 - pilot station). |

2. Check for 115 VAC at (A326):  
TB1-B,  
TB1-E,  
TB1-H.

**Are 3 phases of voltage present?**

- |     |  |
|-----|--|
| YES | Go to step 3.  |
| NO  | Repair open wire between:<br>P477-F and P437 SP3,<br>P437 SP3 and P437-U,<br>P477-D and P437 SP1,<br>P437 SP1 and P437-V,<br>P477-E and P437 SP2,<br>P437 SP2 and P437-W.<br>(A326):<br>TB1-14-B and J8-F,<br>TB1-14-E and J8-D,<br>TB1-14-H and J8-E.<br>(A402):<br>J25-U and J2-K,<br>J25-V and J2-L,<br>J25-W and J2-M.<br>Go to paragraph 13-12. |

3. Check for open between (A326):  
TB1-14-C and XK1-5/6-C2,  
TB1-15-H and XK1-5/6-C1,  
TB1-14-F and XK1-5/6-B2,  
TB1-15-L and XK1-5/6-B1,  
TB1-14-J and XK1-5/6-A2,  
TB1-16-A and XK1-5/6-A1.

**Does open exist?**

- |     |   |
|-----|---|
| YES | Repair open wire.<br>Go to paragraph 13-12. |
| NO  | Go to step 4.                               |

4. Check for 28 VDC between (A326): XK1-5/6-X1 and XK1-5/6-X2.

**Is voltage present?**

- |     |   |
|-----|---|
| YES | Replace relay (A326)K1-5/6 (TM 55-1520-238-23). |
| NO  | Go to step 5.                                   |

**13-25. BOTH FAB NORMAL FANS - DO NOT OPERATE (cont)**

**13-25**

5. Check for 28 VDC at P1-2.  
**Is voltage present?**  
 YES        Go to step 6.  
 NO         Refer to TM 1-1520-238-T-6 to troubleshoot circuit protection system (dc emergency bus - pilot station).
6. Check for 28 VDC at P762-A10.  
**Is voltage present?**  
 YES        Go to step 7.  
 NO         Repair open between: P433-A13 and P762-A10. (A402): J1-2 and J20-A13. Go to paragraph 13-12.
7. Check for 28 VDC at J177-A1.  
**Is voltage present?**  
 YES        Go to step 9.  
 NO         Go to step 8.
8. Check for open between P762-A2 and J177-A1.  
**Does open exist?**  
 YES        Repair open wire. Go to paragraph 13-12.  
 NO         Replace CPG **AUX/ANTI-ICE** panel (TM 55-1520-238-23).
9. Check for 28 VDC at P473-B10.  
**Is voltage present?**  
 YES        Go to step 11.  
 NO         Go to step 10.
10. Check for open between J177-A4 and P473-B10.  
**Does open exist?**  
 YES        Repair open wire. Go to paragraph 13-12.  
 NO         Replace pilot **ECS** panel (TM 55-1520-238-23).
11. Check for open between (A326): J6-B10 and XK1-3/4-D3, XK1-3/4-D2 and XK1-5/6-X1, XK1-5/6-X2 and GS1-A.  
**Does open exist?**  
 YES        Repair open wire. Go to paragraph 13-12.  
 NO         Replace relay (A326)K1-3/4 (TM 55-1520-238-23).

END OF TASK

**13-26. ECS FAB FANS CIRCUIT BREAKER (CB88) - DOES NOT STAY CLOSED WHEN FAB FANS IN STANDBY**

13-26

**Tools:**

<u>Nomenclature</u>	<u>Part Number</u>
Tool Kit, Electrical Repairer's	SC518099CLA06
Multimeter, Digital	AN/PSM-45

**Personnel Required:**

68X Armament/Electrical Systems Repairer

**References:**

TM 55-1520-238-23

**Equipment Conditions:**

<u>Ref</u>	<u>Condition</u>
TM 55-1520-238-23	Non-transparent barrier removed

**WARNING**

**Turn off power before detaching or attaching wires and connectors. High current 28 VDC or 115 VAC is present. Failure to do so could result in death or serious injury.**

1. Check for open between:  
 (A326)TB1-14-M and B8 SP1,  
 (A326)TB1-15-C and B8 SP2,  
 (A326)TB1-15-F and B8 SP3.  
**Does open exist?**

YES	Repair open wire between: P480-A14 and B8 SP1, P480-A15 and B8 SP2, P480-A16 and B8 SP3. (A326): TB1-14-M and J16-A14, TB1-15-C and J16-A15, TB1-15-F and J16-A16. Go to paragraph 13-12.
NO	Go to step 2.

2. Check for open between:  
 (A326)TB1-14-K and B3 SP1,  
 (A326)TB1-15-A and B3 SP2,  
 (A326)TB1-15-D and B3 SP3.

**Does open exist?**

YES	Repair open wire between: P473-A9 and B3 SP1, P473-A10 and B3 SP2, P473-A11 and B3 SP3. (A326): TB1-14-K and J6-A9, TB1-15-A and J6-A10, TB1-15-D and J6-A11. Go to paragraph 13-12.
NO	Go to step 3.

3. Check for open between (B3):  
 SP4 and ground,  
 SP5 and ground,  
 SP6 and ground.

**Does open exist?**

YES	Replace left FAB vaneaxial fan (B3) (TM 55-1520-238-23).
NO	Replace right FAB vaneaxial fan (B8) (TM 55-1520-238-23).

END OF TASK

**13-27. BOTH FAB STANDBY FANS - DO NOT OPERATE**

**13-27**

**Tools:**

<u>Nomenclature</u>	<u>Part Number</u>
Tool Kit, Electrical Repairer's	SC518099CLA06
Multimeter, Digital	AN/PSM-45

**Personnel Required:**

68X Armament/Electrical Systems Repairer  
One person to assist

**References:**

TM 55-1520-238-23

**Equipment Conditions:**

<u>Ref</u>	<u>Condition</u>
TM 55-1520-238-23	Non-transparent barrier removed

3. Check for 28 VDC between (A326):  
XK1-3/4-X1 and XK1-3/4-X2.

**Is voltage present?**

- |     |   |
|-----|---|
| YES | Replace relay (A326)K1-3/4 (TM 55-1520-238-23).   |
| NO  | Repair open wire between (A326):<br>J6-B11 and XK1-3/4-X1,<br>XK1-3/4-X2 and GS1-B.<br>Go to paragraph 13-12. |

4. Check for open between J177-A2 and P473-B11.

**Does open exist?**

- |     |   |
|-----|---|
| YES | Repair open wire.<br>Go to paragraph 13-12.         |
| NO  | Replace pilot <b>ECS</b> panel (TM 55-1520-238-23). |



**Turn off power before detaching or attaching wires and connectors. High current 28 VDC or 115 VAC is present. Failure to do so could result in death or serious injury.**

1. Check for open between (A326):  
TB1-14-A and XK1-3/4-C2,  
TB1-14-D and XK1-3/4-B2,  
TB1-14-G and XK1-3/4-A2,  
TB1-14-L and XK1-3/4-C1,  
TB1-15-B and XK1-3/4-B1,  
TB1-15-E and XK1-3/4-A1.

**Does open exist?**

- |     |   |
|-----|---|
| YES | Repair open wire.<br>Go to paragraph 13-12. |
| NO  | Go to step 2.                               |

2. Check for 28 VDC at P473-B11.

**Is voltage present?**

- |     |               |
|-----|---------------|
| YES | Go to step 3. |
| NO  | Go to step 4. |

END OF TASK



---

**13-28. BOTH FAB STANDBY FANS - DO NOT OPERATE WITH CPG STBY FAN SWITCH SET TO STBY FAN**

---

13-28

**Tools:**

<u>Nomenclature</u>	<u>Part Number</u>
Tool Kit, Electrical Repairer's	SC518099CLA06
Multimeter, Digital	AN/PSM-45

**Personnel Required:**

68X Armament/Electrical Systems Repairer  
One person to assist

**References:**

TM 55-1520-238-23

---

<b>WARNING</b>
----------------

**Turn off power before detaching or attaching wires and connectors. High current 28 VDC or 115 VAC is present. Failure to do so could result in death or serious injury.**

1. Check for 28 VDC at J177-A3.

**Is voltage present?**

YES	Replace pilot <b>ECS</b> panel (TM 55-1520-238-23).
NO	Go to step 2.

2. Check for open between (A417):  
J1-A10 and J1-A1.

**Does open exist?**

YES	Replace CPG <b>AUX/ANTI-ICE</b> panel (TM 55-1520-238-23).
NO	Repair open wire between P762-A1 and J177-A3. Go to paragraph 13-12.

END OF TASK



**CHAPTER 14**  
**HOISTS AND WINCHES (NOT APPLICABLE)**



# CHAPTER 15

## AUXILIARY POWER UNIT

### CHAPTER INDEX

<u>Para Title</u>	<u>Para No.</u>
<b>SECTION I. EQUIPMENT DESCRIPTION AND DATA</b>	
Equipment Characteristics, Capabilities, and Features .....	15-1
Location and Description of Major Components .....	15-2
Equipment Data .....	15-3
Equipment Configuration .....	15-4
Safety, Care and Handling of Equipment .....	15-5
Controls and Indicators .....	15-6
<b>SECTION II. THEORY OF OPERATION</b>	
System Description .....	15-7
Multiplex Read Codes .....	15-8
<b>SECTION III. TROUBLESHOOTING PROCEDURES</b>	
Electrical Component Location and Configuration (ECLC) Index .....	15-9
Auxiliary Power Unit - Power Up .....	15-10
Auxiliary Power Unit - Power Down .....	15-11
Auxiliary Power Unit Power Take Off (PTO) Clutch - Vibration Check .....	15-1 1A
Auxiliary Power Unit - Maintenance Operational Check .....	15-12
Auxiliary Power Unit - Wiring Interconnect Diagram .....	15-13

## SECTION I. EQUIPMENT DESCRIPTION AND DATA

---

### 15-1. EQUIPMENT CHARACTERISTICS, CAPABILITIES, AND FEATURES

15-1

a. **Characteristics.** The auxiliary power unit (APU) is a self-contained, fully automatic constant speed, gas-turbine engine employing a single-stage centrifugal compressor, and a single-stage radial inflow turbine.

b. **Capabilities and Features.** The APU drives the accessory section of the main transmission to provide pneumatic, hydraulic and electrical power to the aircraft. This capability allows the helicopter to be self-supporting in the field.

---

### 15-2. LOCATION AND DESCRIPTION OF MAJOR COMPONENTS

15-2

The APU (fig. 15-1) consists of a motional transducer, igniter unit, hydraulic starter, power take-off (PTO) clutch, controller, exhaust gas temperature (EGT) thermocouple, enclosure, exhaust nozzle, exhaust duct, APU fuel control, low oil pressure (LOP) switch, fuel nozzle, igniter plug and fuel solenoid valve. The APU fuel shutoff valve and APU fuel boost pump also support APU operation.

a. **Motional Transducer.** The motional transducer, located on the right side of the accessory gearbox, measures APU rpm by electrically counting main drive gear teeth.

b. **Igniter Unit.** The igniter unit, located at the top of the accessory gearbox, converts 28 VDC to 2900-3200 VAC for use by the igniter plug.

c. **Hydraulic Starter.** The hydraulic starter, located on the forward section of the accessory gearbox, uses utility hydraulic system pressure to turn over the APU during starting. The starter disengages when the APU attains 60% rpm.

d. **PTO Clutch.** The PTO clutch, located on the forward section of the accessory gearbox, is electrically controlled and provides APU power to the main transmission accessory gearbox.

e. **Controller.** The controller, located on the upper section of the APU enclosure, is a solid state device which accepts input signals for monitoring and provides output signals for controlling. The controller monitors the  $N_R$  rotor speed signal, motional transducer, LOP switch and exhaust gas temperature. The controller provides output signals for APU control of the ignition system, fuel control unit shutoff valve, PTO clutch solenoid, LOP switch, elapsed time indicator, hydraulic start solenoid valve, fault detection and location system (FD/LS) signals, caution/warning indicators and fuel metering.

f. **EGT Thermocouple.** The EGT thermocouple, located on top of the exhaust section, monitors EGT and sends the signal to the APU controller.

g. **Exhaust Nozzle.** The APU exhaust nozzle, located aft of the turbine section, is a corrosion resistant steel duct that directs exhaust gases from the turbine section into the exhaust duct.

h. **Exhaust Duct.** The exhaust duct, located on the aft panel of the APU enclosure, directs APU exhaust gases out of the helicopter and creates airflow through the APU enclosure, cooling APU external components.

i. **APU Fuel Control.** The APU fuel control, located on the left front section of the accessory gearbox, meters the amount of fuel needed for starting, acceleration and normal operation of the APU.

j. **Enclosure.** The APU enclosure consists of five pieces of Kevlar which fit over the APU.

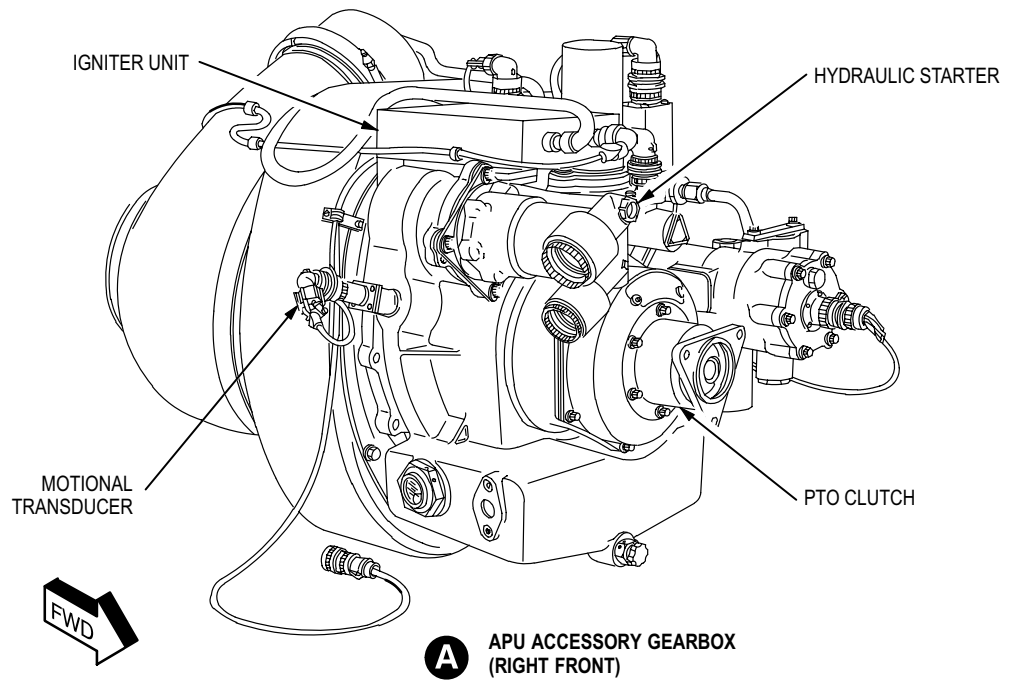
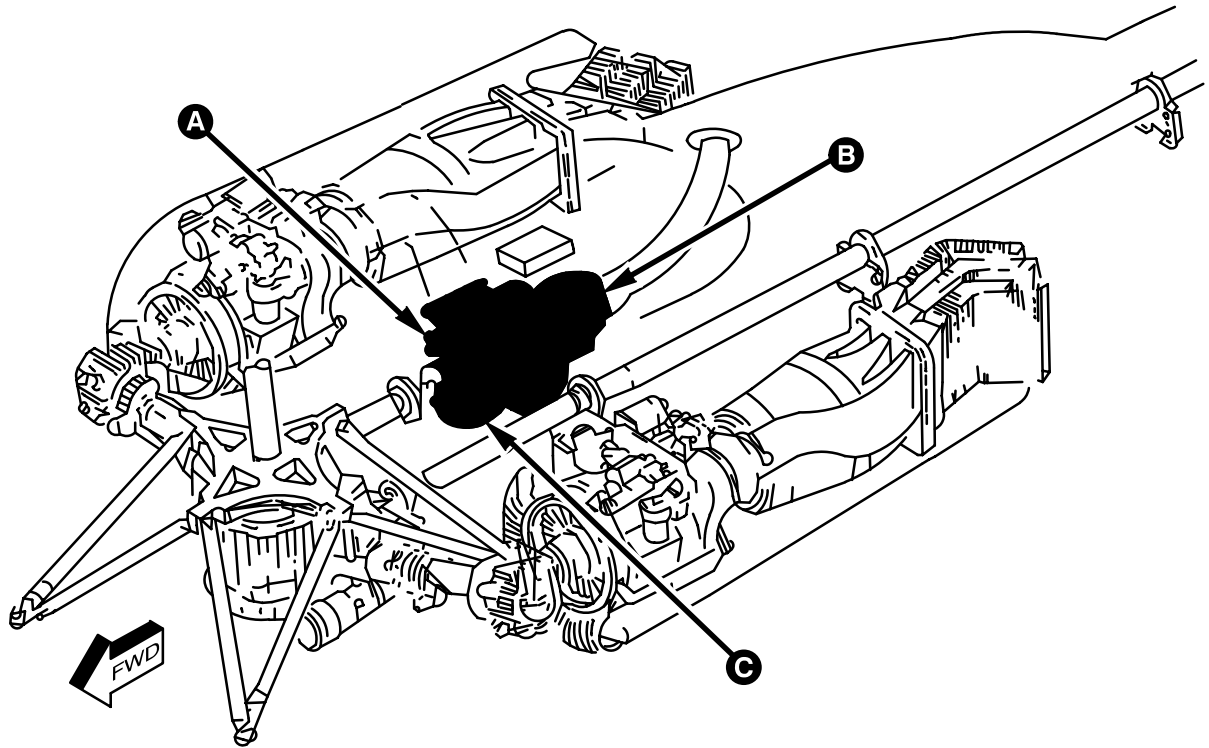

M71-163-1

Figure 15-1. APU Major Components Location (Sheet 1 of 2)

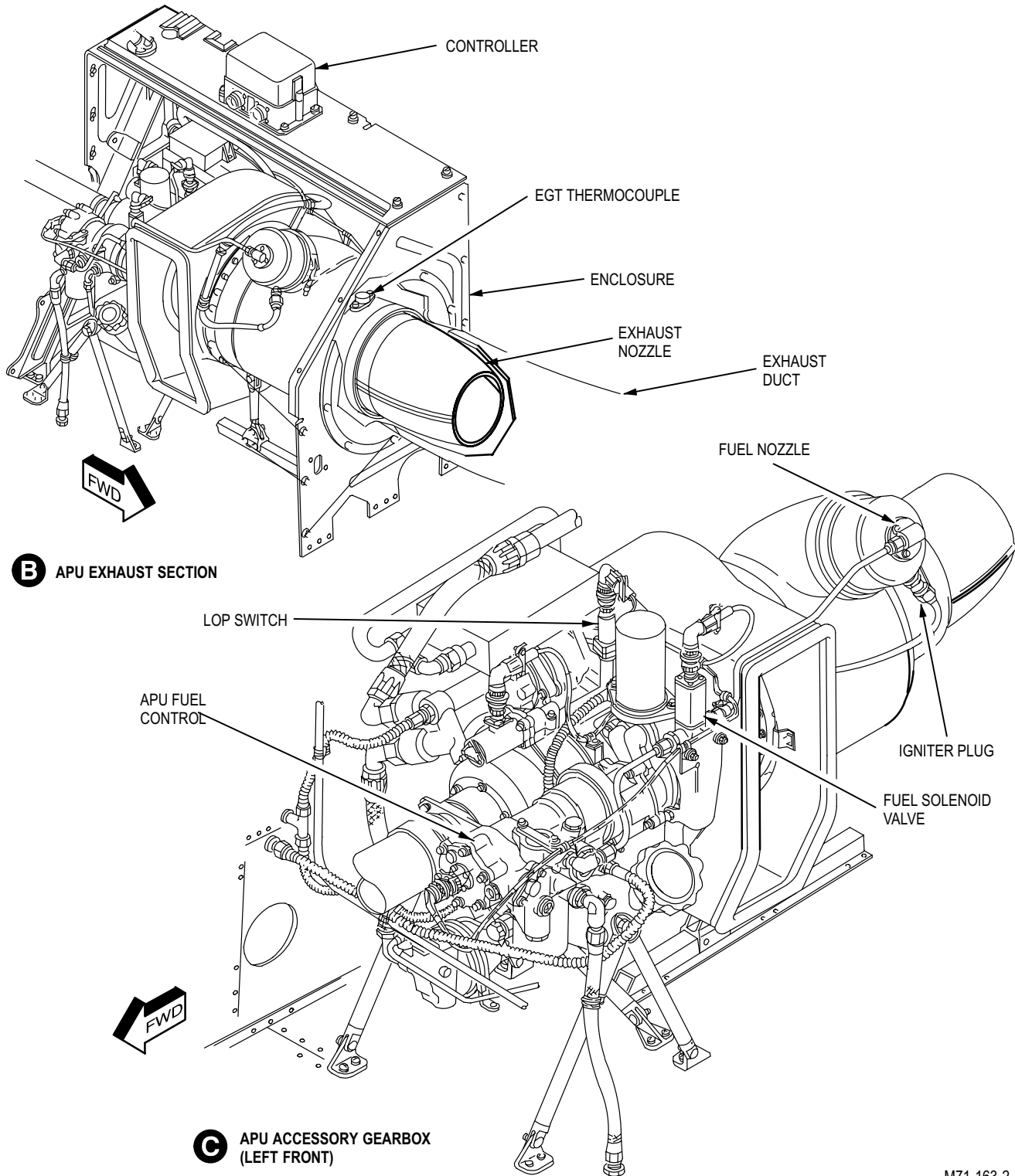

**C** APU ACCESSORY GEARBOX (LEFT FRONT)

M71-163-2

Figure 15-1. APU Major Components Location (Sheet 2 of 2)



---

**15-2. LOCATION AND DESCRIPTION OF MAJOR COMPONENTS (cont)**

---

15-2

- k. **LOP Switch.** The LOP switch, located on the upper aft section of the accessory gearbox, is a normally closed, solenoid operated, pressure activated switch. The LOP switch sends the APU controller a signal when oil pressure drops below 75 psig after the APU reaches 95% rpm.
- l. **Fuel Nozzle.** The fuel nozzle, attached to top of the combustor cap, consists of a primary, secondary and piloted air blast atomizer orifice which makes up a flow divider. The fuel nozzle provides atomized fuel to the combustion section during APU operation.
- m. **Igniter Plug.** The igniter plug, attached to the left side of the combustor cap, provides the spark in the combustion section to ignite the fuel/air mixture during the start sequence.
- n. **Fuel Solenoid Valve.** The fuel solenoid valve, located in the upper aft section of the accessory gearbox, opens at 5% rpm to allow fuel to enter the fuel nozzle.
- o. **APU Fuel Shutoff Valve.** The APU fuel shutoff valve (fig. 15-2), located in the ammunition bay on the right upper aft fuselage panel, is a 28 VDC motor-driven, ball type valve that provides automatic control of fuel flow from the aft fuel cell to the APU fuel boost pump.
- p. **APU Fuel Boost Pump.** The APU fuel boost pump, located in the ammunition bay on the center upper aft fuselage panel, is a pressure regulated, rotary-vane pump that ensures a positive fuel flow to the APU fuel control.

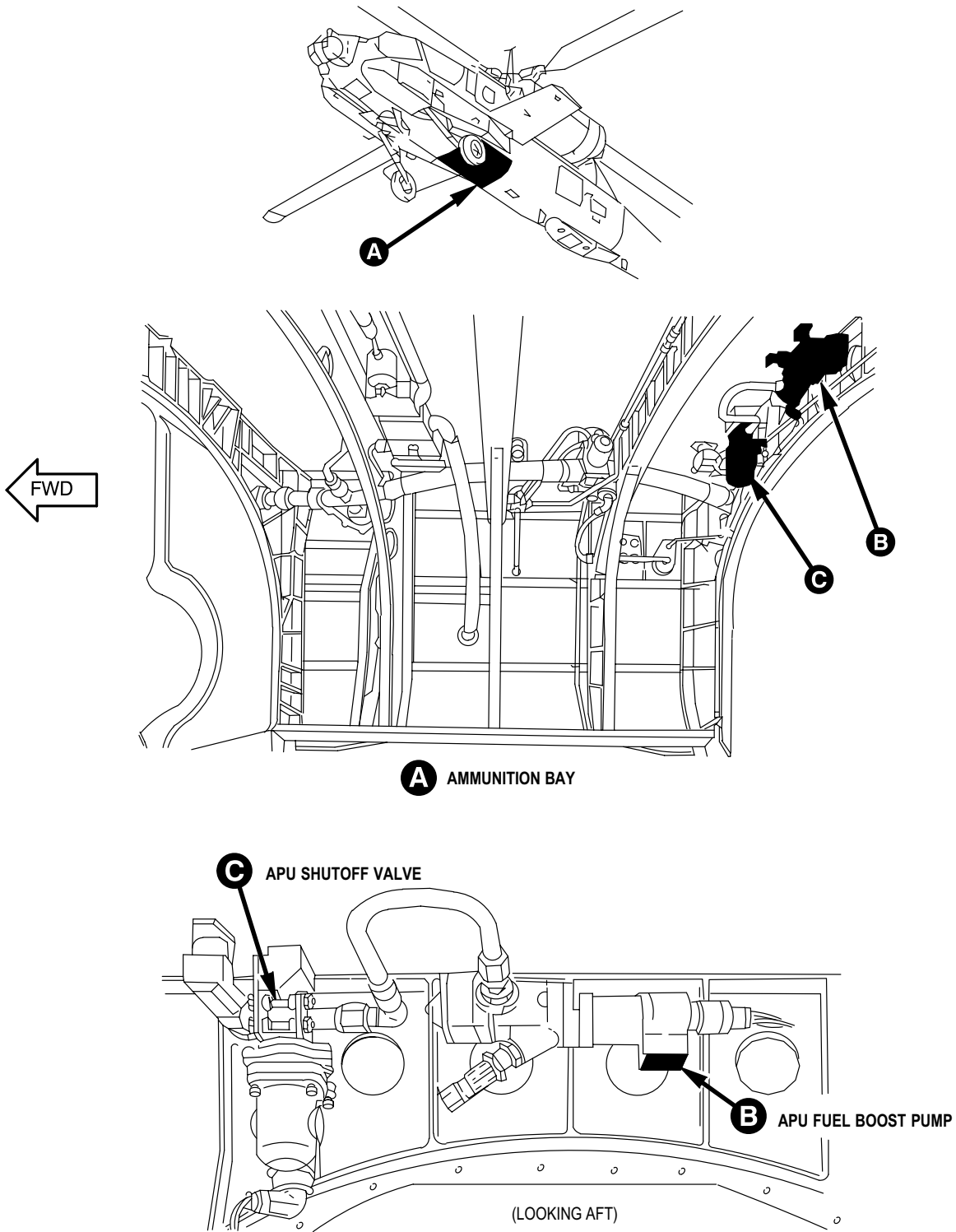

Figure 15-2. APU Fuel Shutoff Valve and APU Fuel Boost Pump Location

M71-164

**15-3. EQUIPMENT DATA****15-3**

Manufacturer .....	Garrett Auxiliary Power Division, Allied Signal Aerospace Company
Model .....	GTCP36-55(H)
Type of engine .....	Gas turbine
Weight (dry) .....	100 pounds
Output power .....	125 shaft horsepower
Engine speeds	
Turbine rotor .....	59,566 rpm
PTO clutch .....	CCW 8216 rpm
Electrical system .....	14 to 34 VDC
Lubrication system	
Lubrication specification .....	MIL-L-23699 or MIL-L-7808
Sump capacity .....	2 U.S. quarts
Fuel system	
Fuel specification .....	Grades JP4, JP5 and JP8
Fuel consumption .....	135 pounds per hour (pph)
Automatic shutdown features	
Overspeed .....	107% (63,736 rpm)
Overcurrent	
Fuel shutoff valve solenoid .....	1.2 +0.5 Amp
Ignition unit .....	4.0 +0.5 Amp
PTO clutch solenoid .....	1.0 +0.5 Amp
Start valve solenoid .....	1.0 +0.5 Amp
Low oil pressure .....	75 psig min
Operating range .....	-65 ° to 135° F (-54° to 57° C) sea level to 15,000 feet
Over temperature .....	1785° F (974° C) at 60% APU speed 1325° F (719° C) at 100% APU speed
Start motor hydraulic fluid .....	MIL-H-83282 or MIL-H-5606

**15-4. EQUIPMENT CONFIGURATION**

**15-4**

Not applicable.

**15-5. SAFETY, CARE AND HANDLING OF EQUIPMENT**

**15-5**

Not applicable.

**15-6. CONTROLS AND INDICATORS**

**15-6**

The APU receives mode selects and remote switch inputs from various controls located within the pilot station (fig. 15-8) and copilot/gunner (CPG) station (fig. 15-4). Table 15-1 provides a listing of the controls, switches and associated indicators pertaining to the APU along with a description of their function.

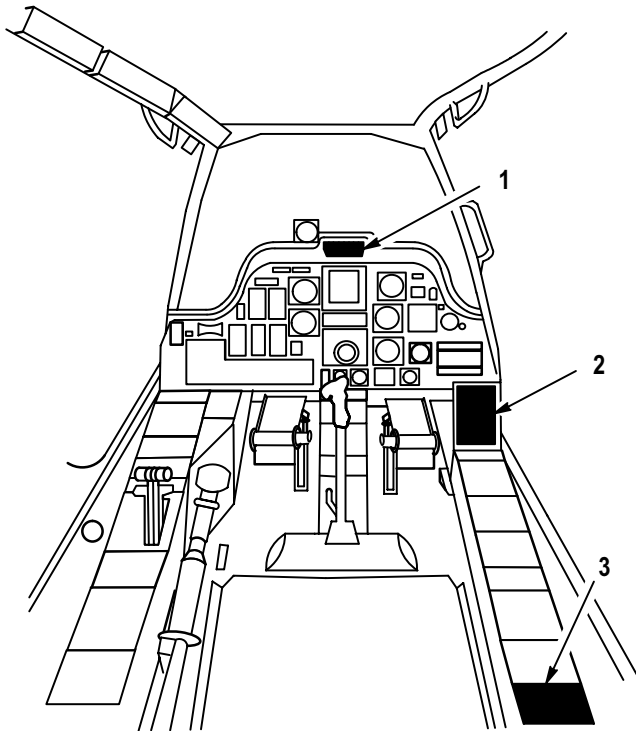

- 1. PILOT MASTER CAUTION / WARNING PANEL
- 2. PILOT CAUTION / WARNING PANEL
- 3. PILOT APU FIRE TEST PANEL

M71-166A

**Figure 15-3. Pilot Station**

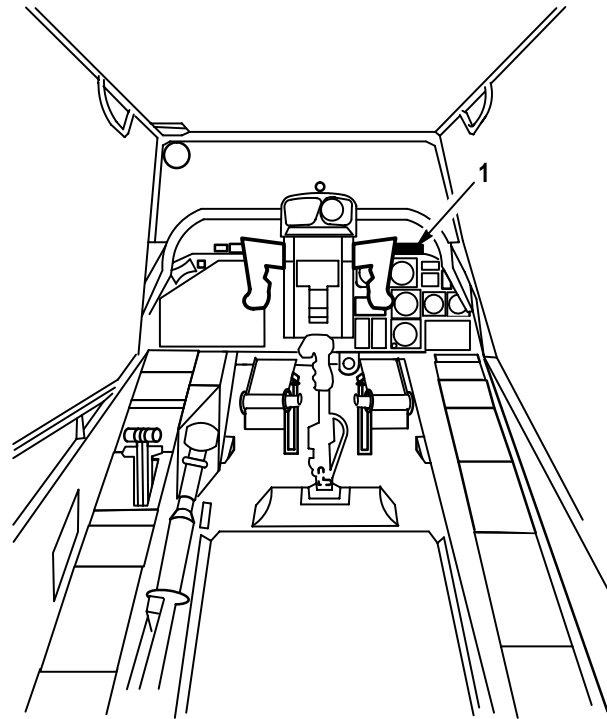

- 1. CPG MASTER CAUTION / WARNING PANEL

M71-220

**Figure 15-4. CPG Station**

Table 15-1. APU Controls and Indicators

Pilot APU Fire Test Panel		
SWITCH/INDICATOR	POSITION	FUNCTION
<b>APU FIRE PULL</b> handle	RED	Lights when fire exists in the APU shroud or may be an indication of a fire in the transmission area.
<b>PRI DISCH</b> indicator	GREEN	Lights when the primary fire bottle has discharged.
<b>RES DISCH</b> indicator	GREEN	Lights when the secondary fire bottle has discharged.
<b>FIRE TEST DET</b> switch	<b>OFF</b>	De-energizes fire detection test circuitry.
	<b>1</b>	Lights the <b>APU FIRE PULL</b> handles to indicate that the upper flame detector circuits and components are functioning.
	<b>2</b>	Lights the <b>APU FIRE PULL</b> handles to indicate that the lower flame detector circuits and components are functioning.
<b>95%/NORM</b> switch	<b>95%</b>	Starts APU during cold temperatures (outside air temperature 0° F (-18° C) or below).
	<b>NORM</b>	Starts APU during normal operating temperatures (outside air temperature above 0° F (-18° C)).
<b>START/RUN/OFF</b> switch	<b>START</b>	Initiates APU automatic start sequence.
	<b>RUN</b>	Allows steady state automatic APU operation. (The switch is spring loaded from the <b>START</b> to the <b>RUN</b> position.)
	<b>OFF</b>	De-energizes APU.

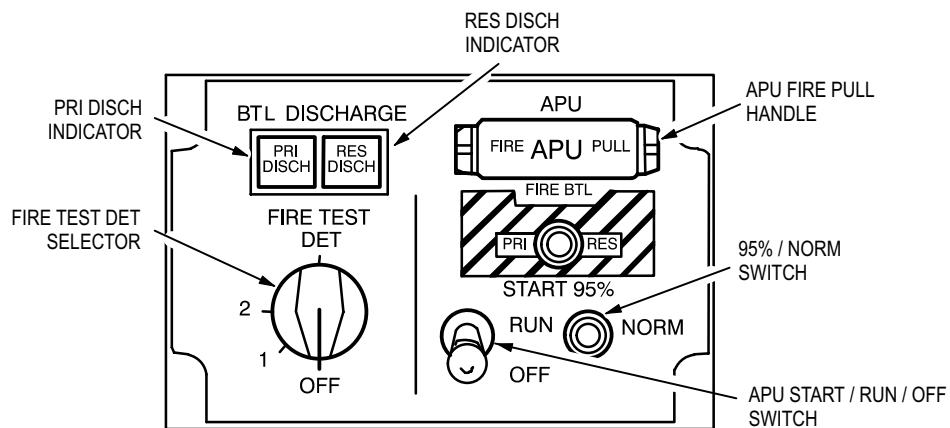

M71-167

Pilot APU Fire Test Panel

Table 15-1. APU Controls and Indicators (cont)

Pilot Caution/Warning Panel		
SWITCH/INDICATOR	POSITION	FUNCTION

<b>APU ON</b> indicator	AMBER	Lights when the APU reaches 95% rpm.
<b>APU FAIL</b> indicator	AMBER	Lights when oil pressure drops to 75 psig, after the APU reaches 95% rpm.

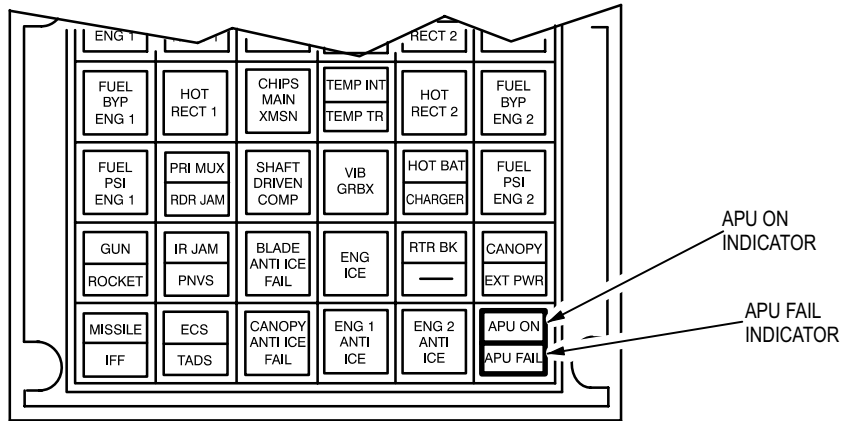

M71-168

**Pilot Caution/Warning Panel**

Master Caution/Warning Panel		
SWITCH/INDICATOR	POSITION	FUNCTION

<b>FIRE APU</b> indicator	RED	Lights when fire exists in the APU shroud.
---------------------------	-----	--

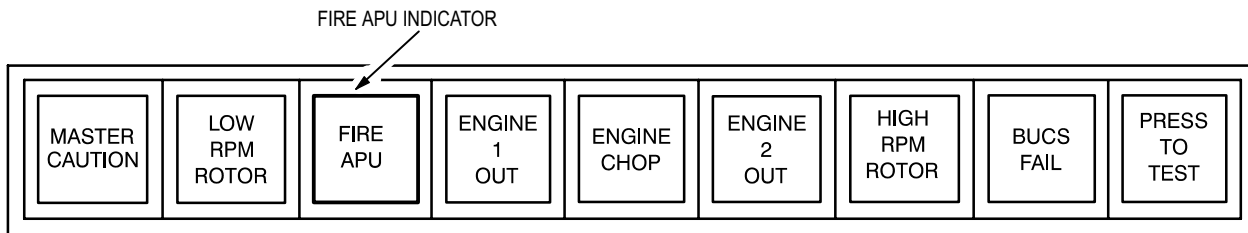

M71-169

**Master Caution/Warning Panel**

15-6. CONTROLS AND INDICATORS (cont)

15-6

Table 15-1. APU Controls and Indicators (cont)

Elapsed Time Indicator		
SWITCH/INDICATOR	POSITION	FUNCTION

HOURS indicator		Indicates the operating hours of the APU.
-----------------	--	---

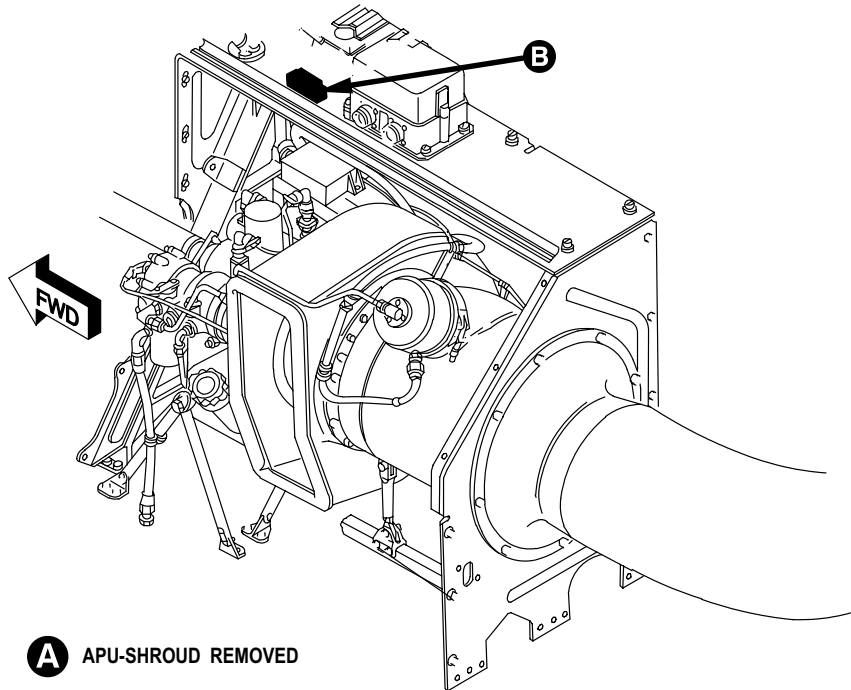
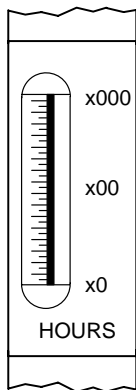
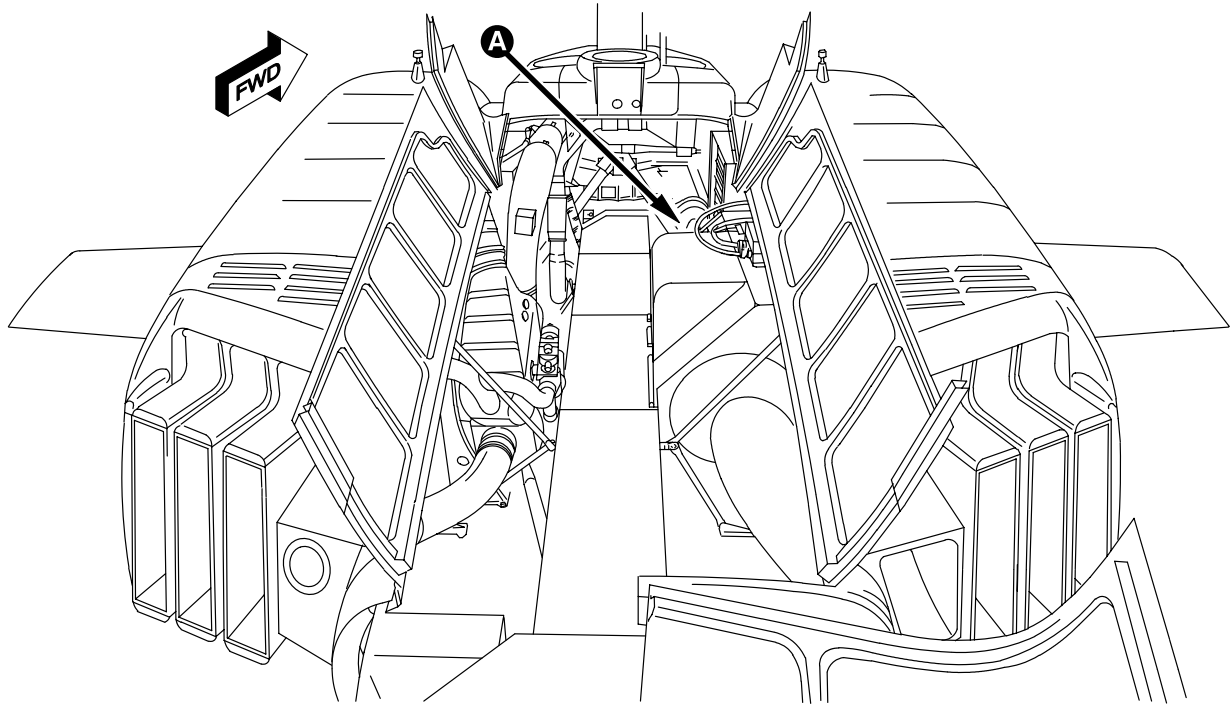

**B** ELAPSED TIME INDICATOR

**A** APU-SHROUD REMOVED

Elapsed Time Indicator

M71-221

## SECTION II. THEORY OF OPERATION

### 15-7. SYSTEM DESCRIPTION

15-7

a. **APU.** The APU (fig. 15-5) provides transmission accessory gearbox drive power when the engines are not operating. This provides the helicopter with self-support in a field environment by eliminating the need for an external source of power.

(1) The APU requires dc power, fuel, and input signals from the helicopter for operation. The APU operates on JP4, JP5, or JP8 fuel. At full load it consumes approximately 155 pph of fuel. The unit is started with a hydraulic starter using hydraulic pressure from the accumulator.

(2) The APU, indirectly through the transmission accessory gearbox, drives two ac generators, two hydraulic pumps, and the shaft driven compressor (SDC). This provides both 115 VAC, 400 Hz and 28 VDC electrical power, 3,000 psi at six gpm hydraulic power, and the pressurized air system (PAS) air pressure to the helicopter. Electrical, hydraulic, and PAS systems and components can be operated and tested without the need for external power. The engines can also be started utilizing APU power. Engagement/disengagement of the APU to/from the transmission is accomplished utilizing an electrically operated PTO clutch.

(3) The APU automatically shuts itself down under any of the following conditions: overspeed; overcurrent at the fuel shutoff valve solenoid, ignition unit, PTO clutch solenoid, or start valve solenoid; low oil pressure; over temperature; loss of temperature signal from the thermocouple.

(4) The APU is equipped with an oil level sight-glass, a magnetic (chip) oil plug, and an oil filtering system to remove contaminants and other impurities from the oil. The unit also has an air inlet screen to filter the air before it is drawn into the compressor. The fuel control inlet contains a cone shaped screen to filter the fuel. The APU exhaust is vented overboard just aft of the engine 2 nacelle.

b. **Purpose.** The APU drives the main transmission accessory section to provide pneumatic, hydraulic, and electrical power.

c. **System Operation.** Start/run power is supplied by the battery through **APU** circuit breaker (CB148) and **APU HOLD** circuit breaker (CB10) to the **APU** fire test panel. When the **START/RUN/OFF** switch is positioned to **START**, **FUEL APU** circuit breaker (CB9) supplies 28 VDC to the APU boost pump and APU fuel shutoff valve. The APU boost pump and APU fuel shutoff valve are energized open to provide fuel for the APU. **FUEL BST** circuit breaker (CB76) supplies 28 VDC to de-energize the SDC throttle valve for 60 seconds and energize the APU controller. The APU controller energizes the APU start solenoid, initiating the start sequence. The **APU FAIL** indicator on the pilot's caution/warning panel is lit and goes out when APU oil pressure is above 75 pounds per square inch (psi).

(1) With hydraulic pressure rotating the APU at 5% APU speed, the APU controller energizes the fuel control unit shutoff valve open and excites the igniter unit. The igniter unit is a low voltage capacitive discharge system which supplies a series of high energy sparks to the igniter for combustion. At 60% APU speed the start solenoid valve is de-energized closed by the APU controller. If the helicopter main rotor speed is below 95%  $N_R$ , the PTO clutch solenoid energizes, engaging the PTO clutch. The PTO clutch drives the main transmission accessory section. The PTO clutch solenoid de-energizes when the main rotor speed is above 95%  $N_R$  and disengages the PTO clutch. When the PTO clutch is disengaged, the APU no longer drives the main transmission accessory section. At 95% APU speed, the APU controller de-energizes the ignition system and the **APU ON** indicator on the pilot caution/warning panel lights. The APU rpm stabilizes at 100% rpm. The elapsed time indicator is operating whenever the PTO clutch is engaged.



15-7. SYSTEM DESCRIPTION

15-7

(2) The **APU 95%** switch is used when the outside air temperature is 0° F (-18° C) or less. The **APU 95%** switch delays PTO clutch engagement until the **APU ON** indicator on the pilot caution/ warning panel lights. The **APU ON** indicator indicates that the APU has reached 95% rpm.

(3) The APU controller monitors the APU for faults. The motional transducer is monitored for loss of signal and rpm above 107% (overspeed). The thermocouple is monitored for loss of signal, temperatures above 1,785° F (975° C) at 60% rpm, and 1,325° F (719° C) at 100% rpm (overtemp). The low oil pressure switch is monitored for low oil pressure. The fuel control unit shutoff valve, igniter unit, start solenoid valve and PTO clutch solenoid are monitored for overcurrent. If a failure occurs, the APU controller automatically shuts down the APU and provides system status to the fire control computer (FCC) via the digital automatic stabilization equipment computer (DASEC).

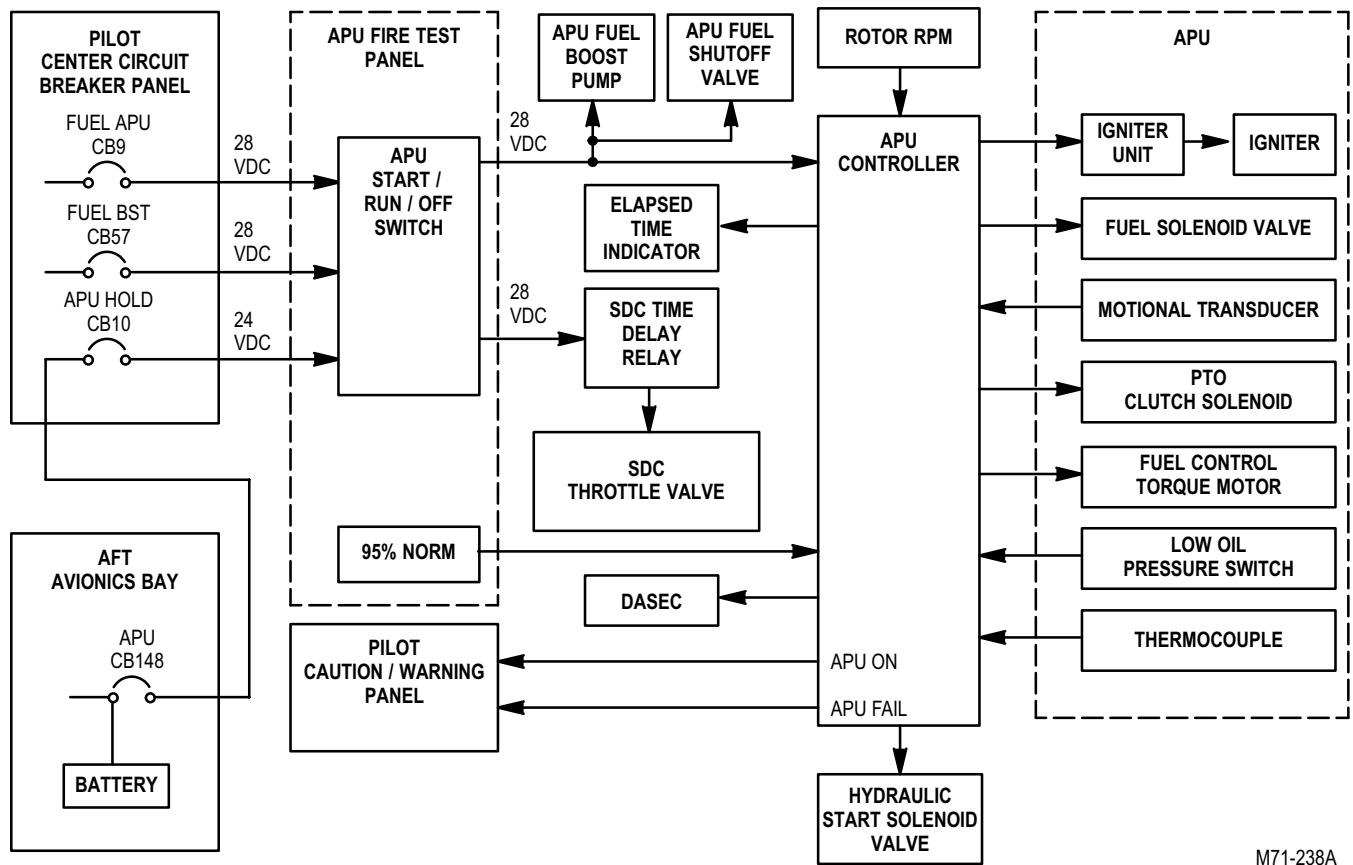

M71-238A

Figure 15-5. APU Functional Block Diagram

15-8. MULTIPLEX READ CODES

15-8

The APU communicates with the FCC. The FCC uses multiplex read codes to issue instructions and to determine system/line replaceable unit (LRU) status. See TM 1-1520-238-T-3, Multiplex Read Codes, for help in using these codes to troubleshoot the APU.

## SECTION III. TROUBLESHOOTING PROCEDURES

## 15-9. ELECTRICAL COMPONENT LOCATION AND CONFIGURATION (ECLC) INDEX

15-9

Use the information in Table 15-2 to locate the electrical components and their connectors to perform the troubleshooting tasks in this chapter. Table 15-2 includes locator illustrations which supplement the ECLC listing. The listing entry in the grid area column tells you where to locate the component in the illustrations.

*Table 15-2. Electrical Component Location and Configuration (ECLC) Index Listing*

FROM COLUMN		TO COLUMN		Grid Area	Access
Connector Ref Des	Component/Harness	Connector Ref Des	Component/Harness		
P1	W605	J1	A402	24A	PLT STATION
P10	388085	J10	APU	40D	T290R DOOR
P176	W118	J1	A138	15B	PLT STATION
P18	W118	J1	A106	17C	PLT STATION
P2	APU	J2	A6	35E	R325 DOOR
P404	W102	J904	W118	31E	R295 DOOR
P430	W108	J6	A402	22B	PLT STATION
P433	W119	J20	A402	23E	PLT STATION
P4	388085	J4	APU	39E	T290R DOOR
P440	W118	J16	A402	22C	PLT STATION
P444	W268	J31	A402	22C	PLT STATION
P463	W119	J1	A76	12D	PLT STATION
P480	W118	J16	A326	5B	CPG STATION
P488	W118	J18	A402	22C	PLT STATION
P492	W102	J492	W118	31E	R295 DOOR
P50	W102	J1	A6	36D	R325 DOOR
P51	W102	J1	HP3	34B	R325 DOOR
P52	W268	J1	L20	44C	B200
P6	388085	J6	APU	37B	T290R DOOR
P683	W211	J4	A69	48D	R295 DOOR
P688	W211	J1	A69	48C	R295 DOOR

15-9. ELECTRICAL COMPONENT LOCATION AND CONFIGURATION (ECLC) INDEX (cont)

15-9

*Table 15-2. Electrical Component Location and Configuration (ECLC) Index Listing (cont)*

FROM COLUMN		TO COLUMN		Grid Area	Access
Connector Ref Des	Component/Harness	Connector Ref Des	Component/Harness		
P7	388085	J7	APU	39E	T290R DOOR
P755	W211	J755	W110	28C	T250L DOOR
P8	388085	J8	APU	38E	T290R DOOR
P9	388085	J9	APU	40D	T290R DOOR
P910	W102	J910	W211	48B	R295 DOOR
P916	W118	J916	W119	1D	CPG STATION
P941	W268	J1	L44	44D	B200

Table 15-2. Electrical Component Location and Configuration (ECLC) Index Listing (cont)

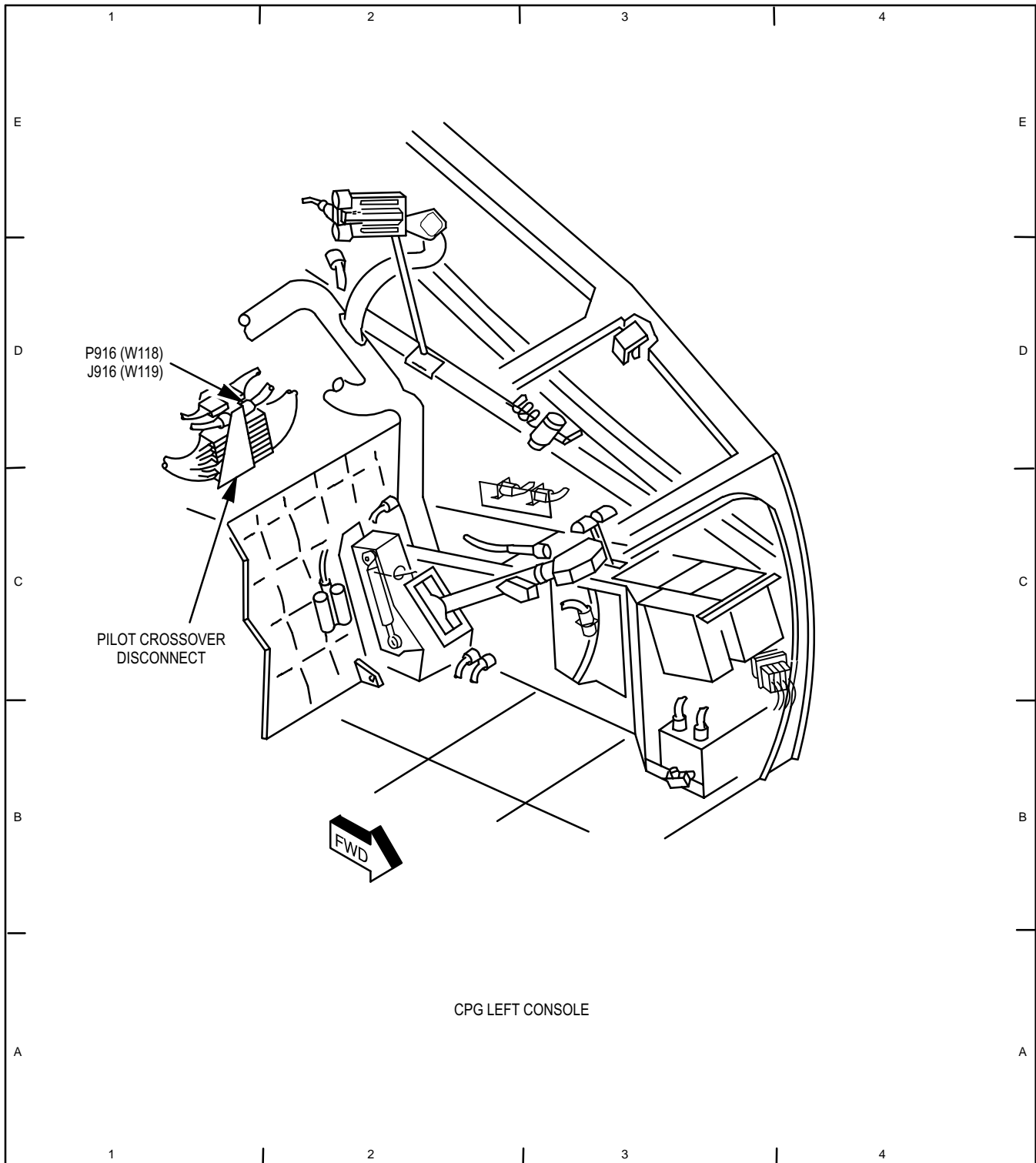

M71-289

15-9. ELECTRICAL COMPONENT LOCATION AND CONFIGURATION (ECLC) INDEX (cont)

15-9

Table 15-2. Electrical Component Location and Configuration (ECLC) Index Listing (cont)

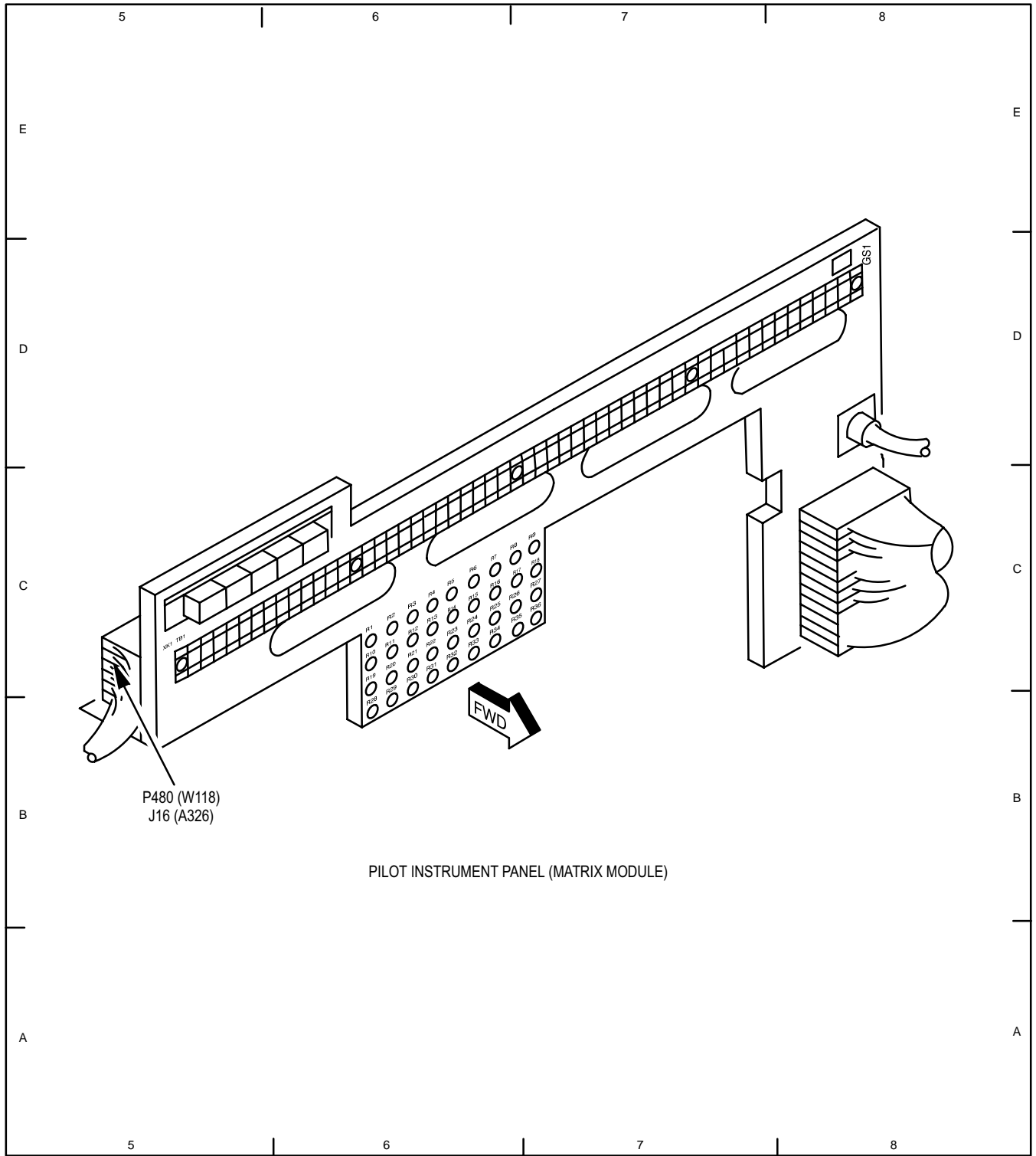

M71-290

Table 15-2. Electrical Component Location and Configuration (ECLC) Index Listing (cont)

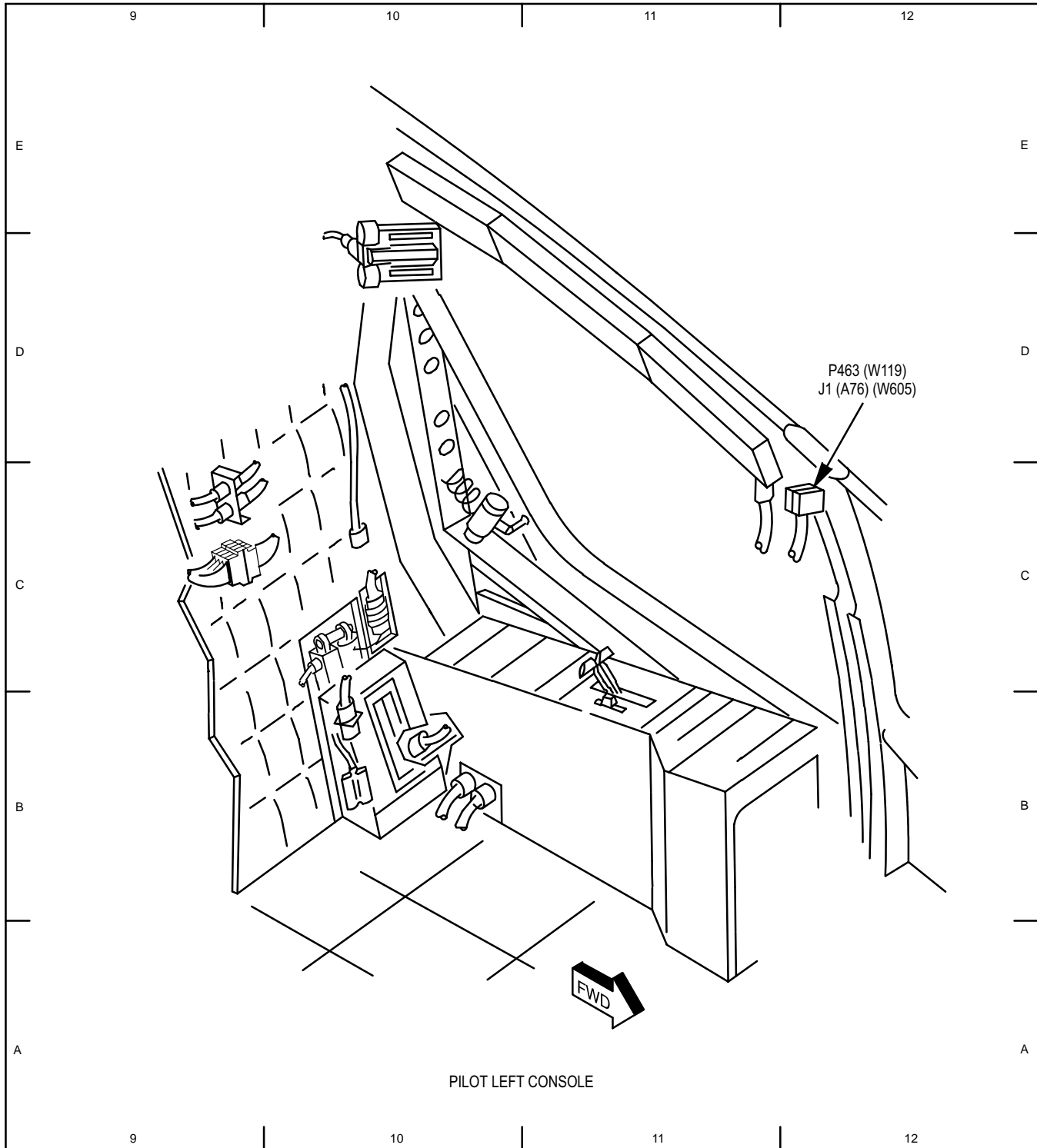

M71-291

15-9. ELECTRICAL COMPONENT LOCATION AND CONFIGURATION (ECLC) INDEX (cont)

15-9

Table 15-2. Electrical Component Location and Configuration (ECLC) Index Listing (cont)

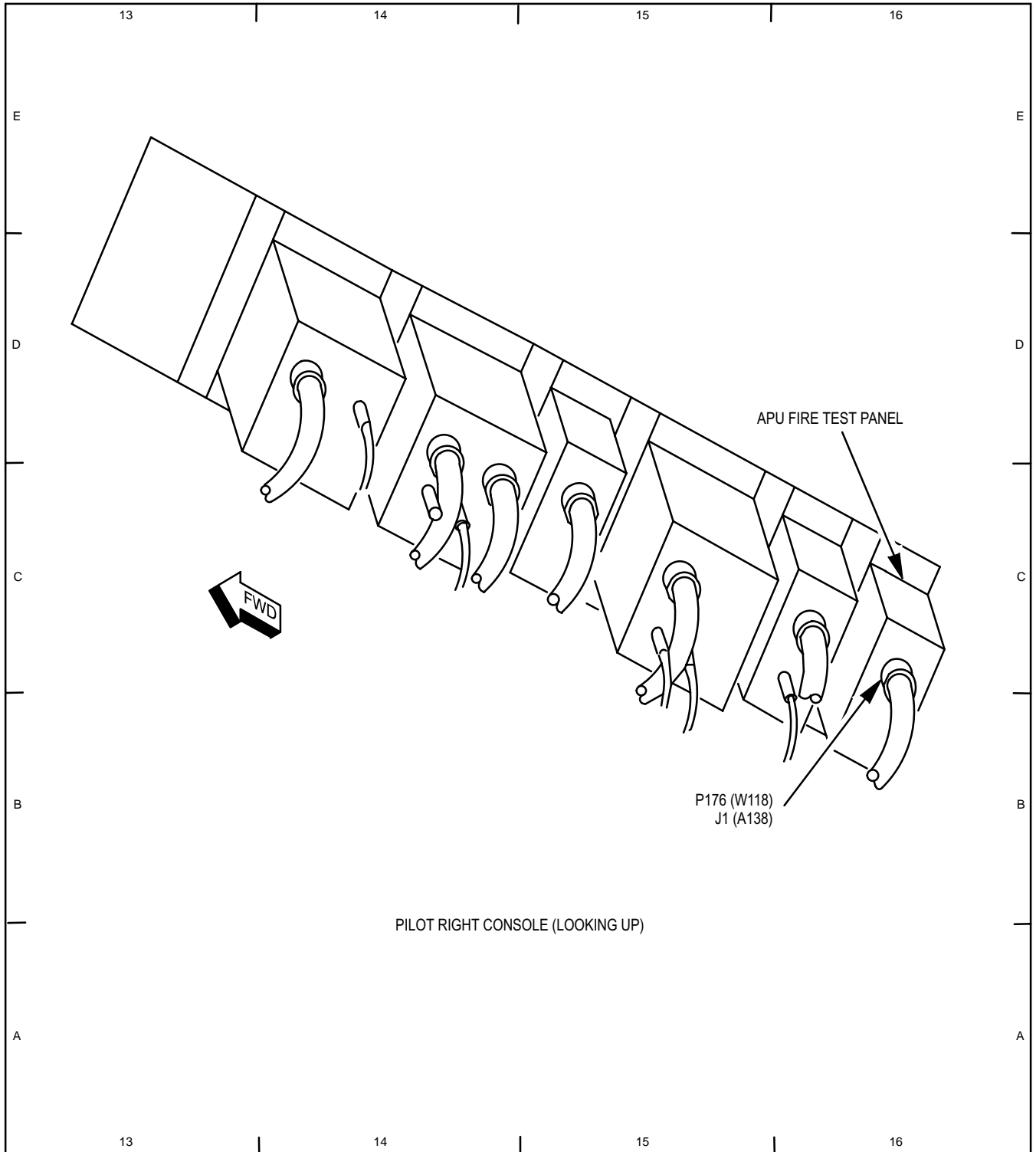

M71-292

Table 15-2. Electrical Component Location and Configuration (ECLC) Index Listing (cont)

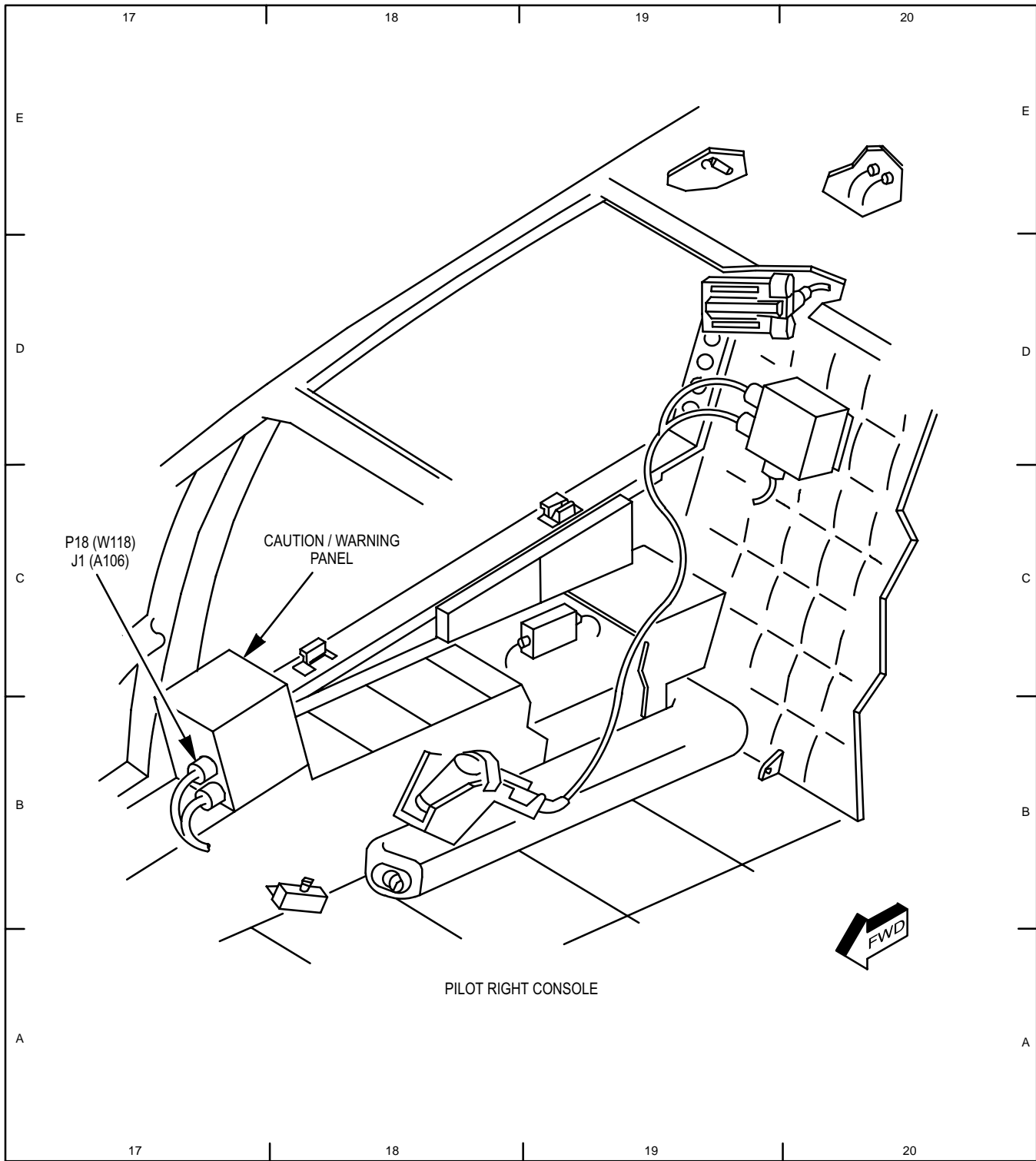

M71-293



15-9. ELECTRICAL COMPONENT LOCATION AND CONFIGURATION (ECLC) INDEX (cont)

15-9

Table 15-2. Electrical Component Location and Configuration (ECLC) Index Listing (cont)

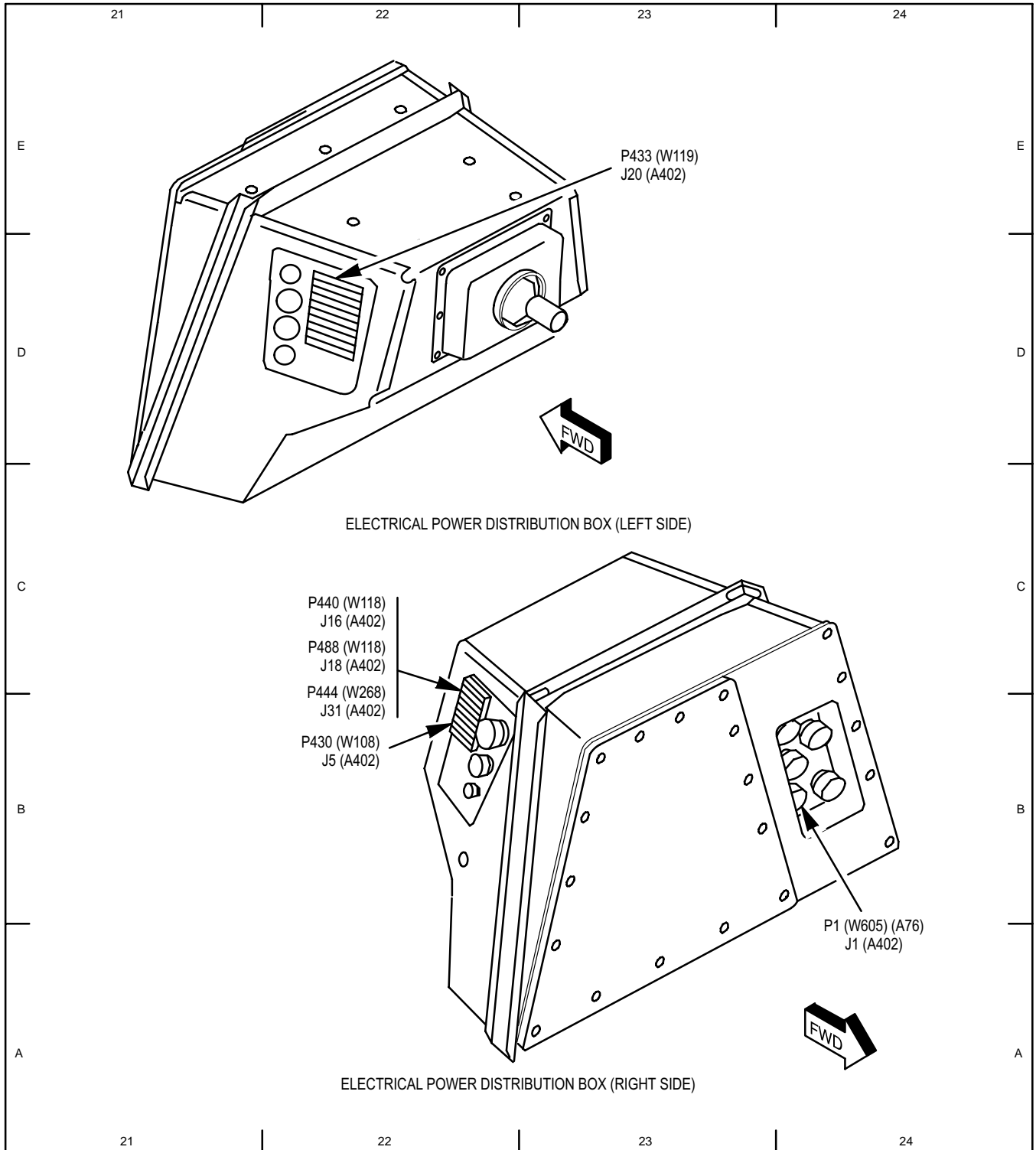

M71-294

Table 15-2. Electrical Component Location and Configuration (ECLC) Index Listing (cont)

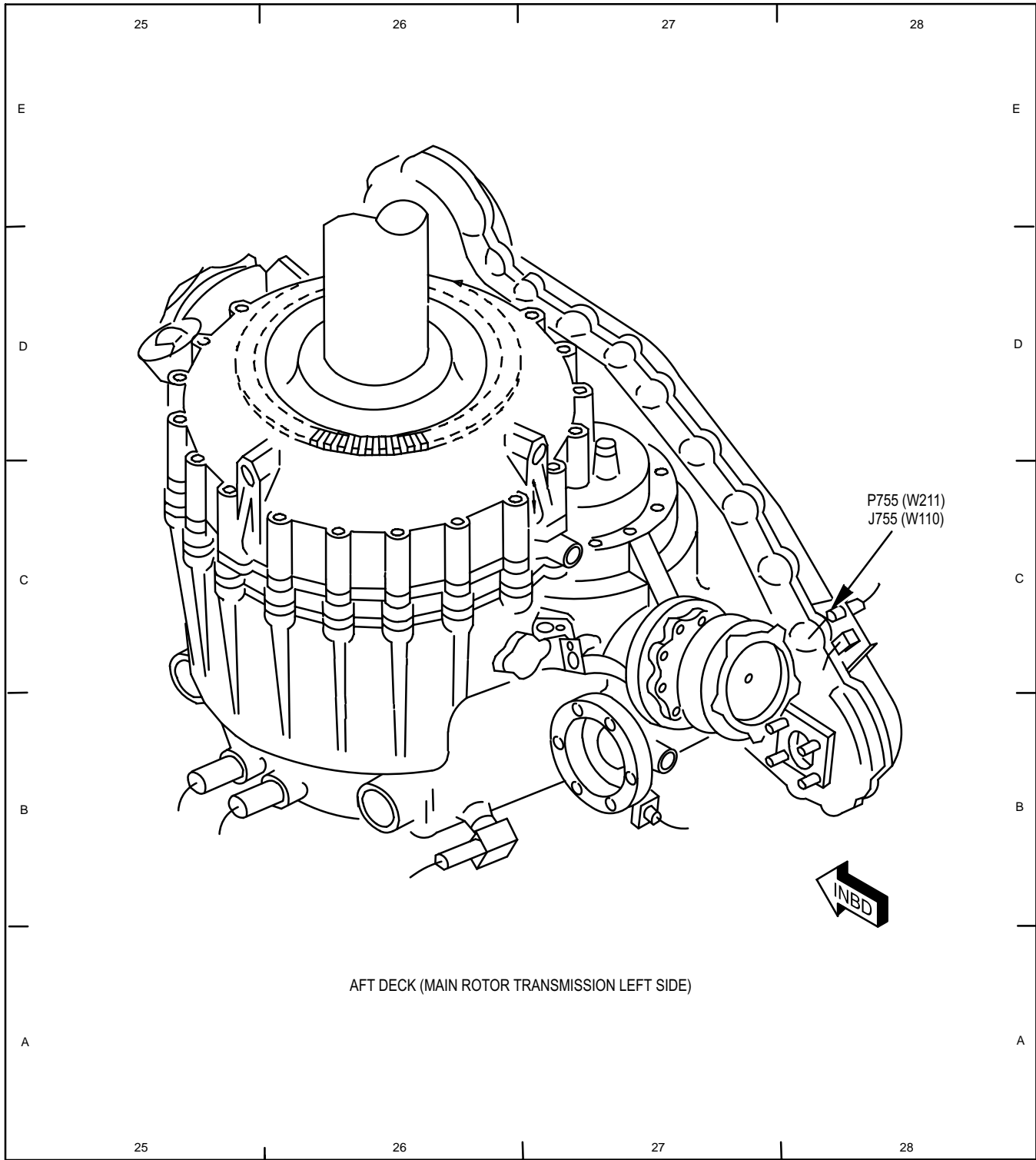

M71-295

15-9. ELECTRICAL COMPONENT LOCATION AND CONFIGURATION (ECLC) INDEX (cont)

15-9

Table 15-2. Electrical Component Location and Configuration (ECLC) Index Listing (cont)

7

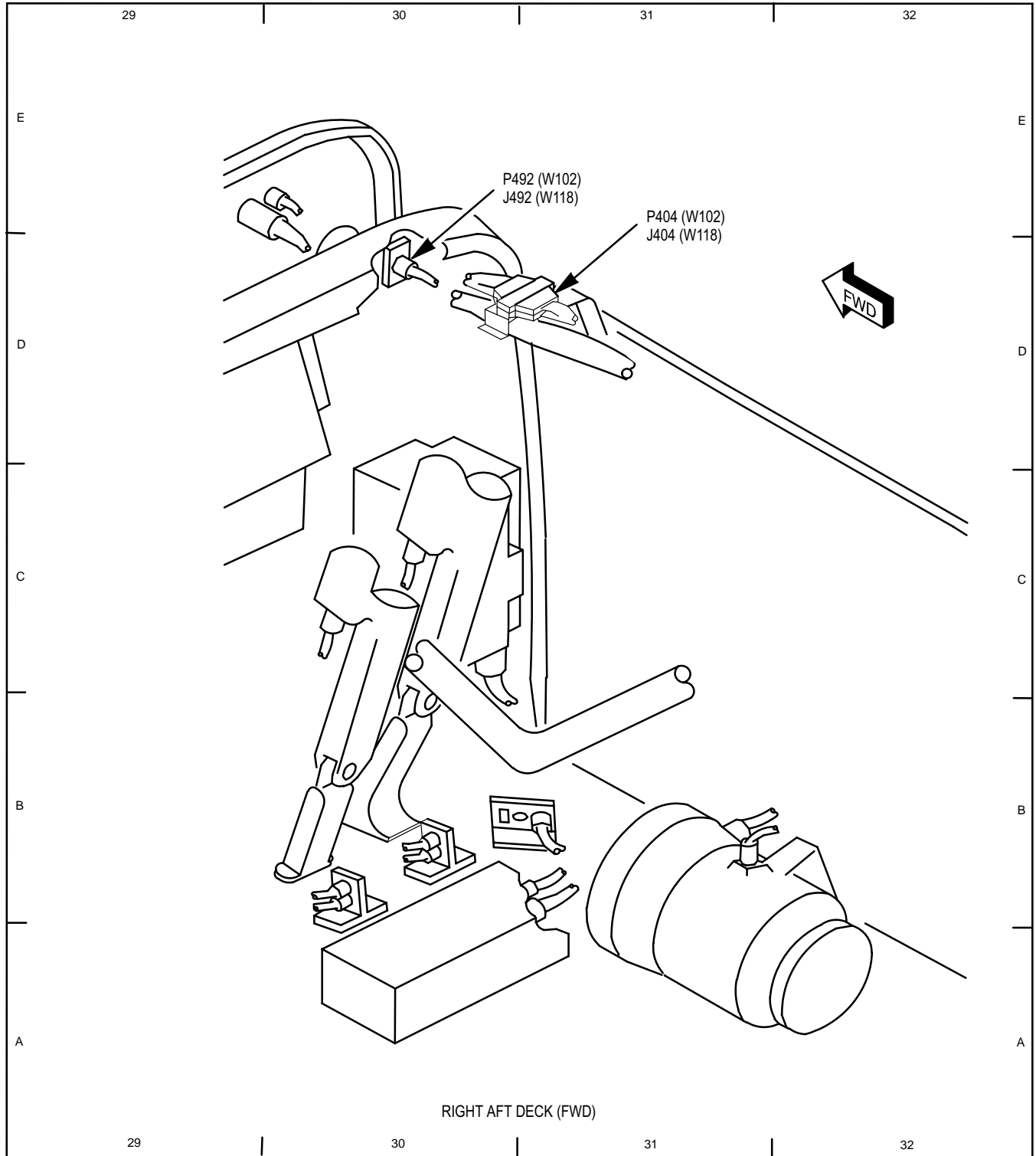

M71-296

Table 15-2. Electrical Component Location and Configuration (ECLC) Index Listing (cont)

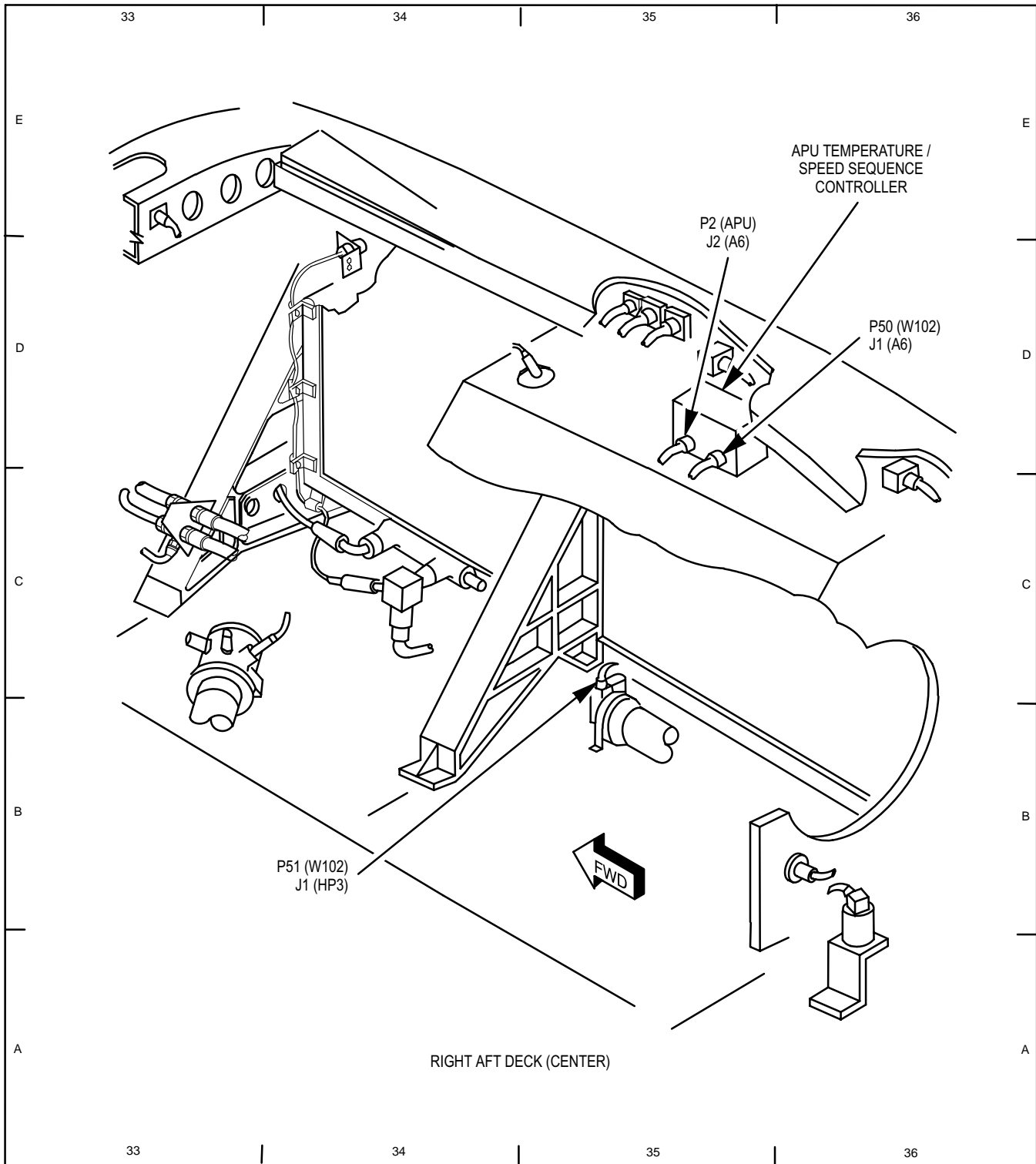

M71-297

15-9. ELECTRICAL COMPONENT LOCATION AND CONFIGURATION (ECLC) INDEX (cont)

15-9

Table 15-2. Electrical Component Location and Configuration (ECLC) Index Listing (cont)

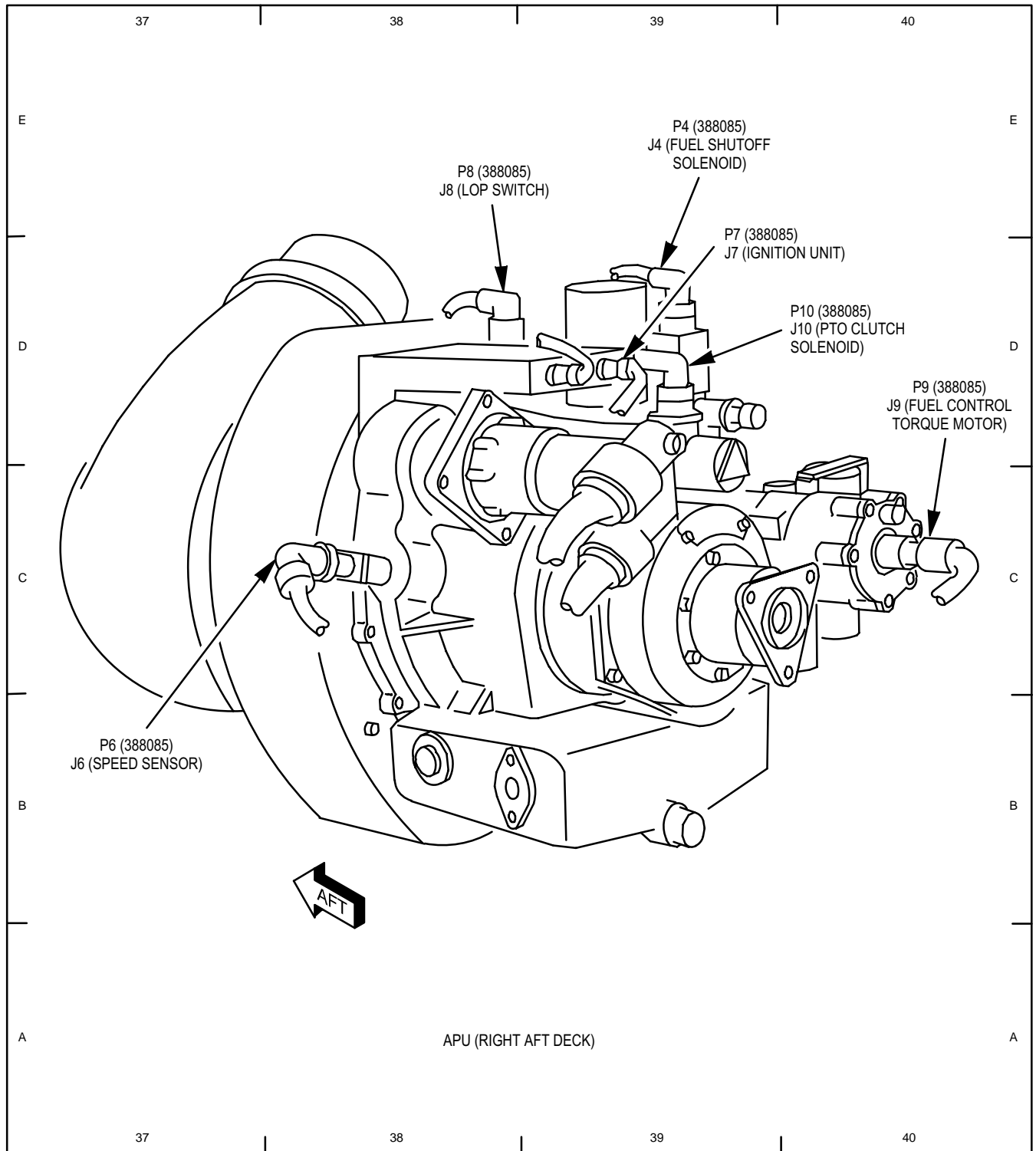

M71-298

Table 15-2. Electrical Component Location and Configuration (ECLC) Index Listing (cont)

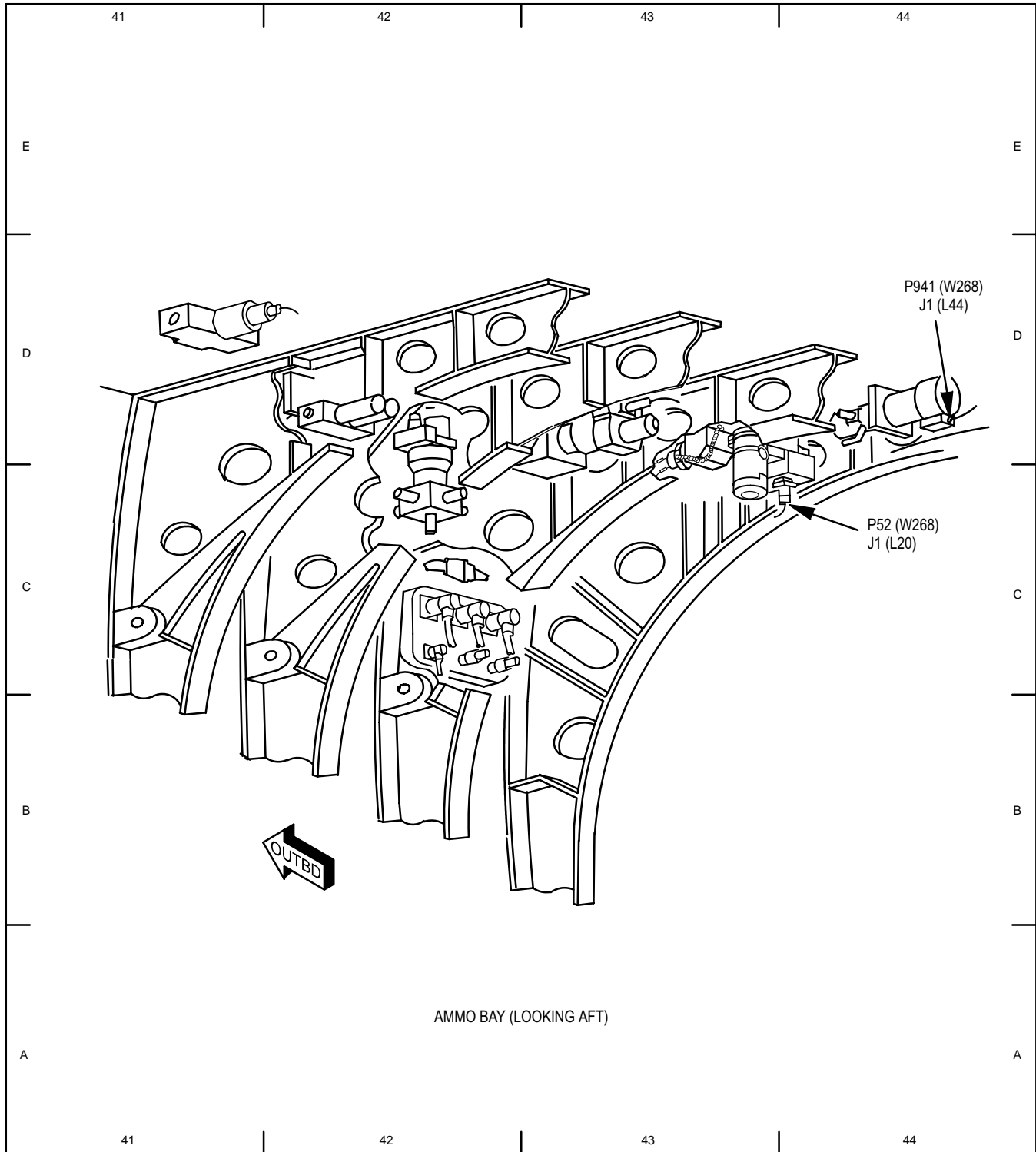

M71-299

15-9. ELECTRICAL COMPONENT LOCATION AND CONFIGURATION (ECLC) INDEX (cont)

15-9

Table 15-2. Electrical Component Location and Configuration (ECLC) Index Listing (cont)

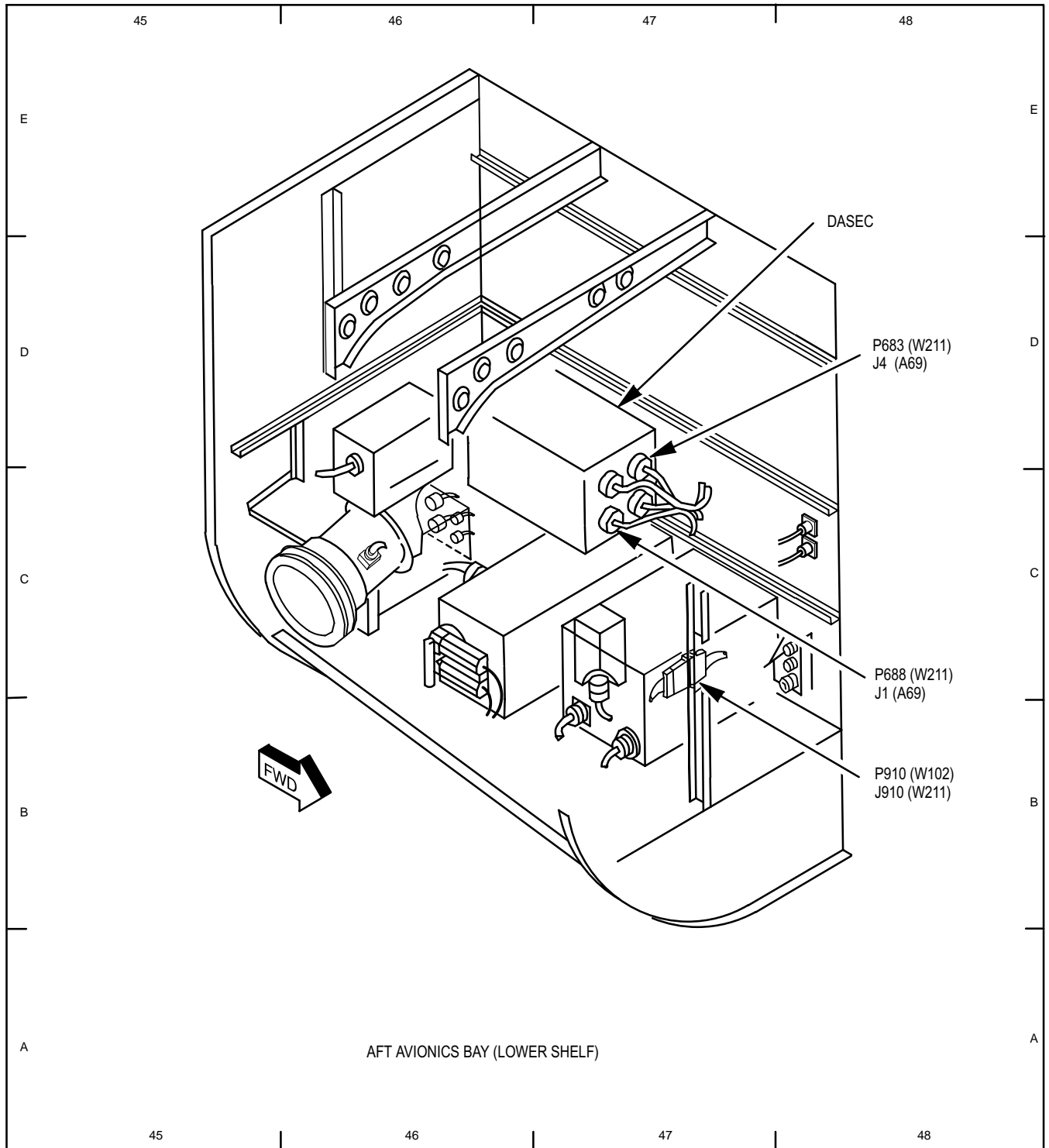

M71-300

15-10. AUXILIARY POWER UNIT - POWER UP

15-10

**Tools:**

<u>Nomenclature</u>	<u>Part Number</u>
Tool Kit, Aircraft Mechanic's	SC518099CLA01

**Equipment Conditions:**

<u>Ref</u>	<u>Condition</u>
TM 1-1520-238-23	Helicopter safed External power application - Electrical
TM 1-1520-238-T-4	Maintenance headset connected
TM 1-1520-238-T-7	Fuel system visual check completed

**Personnel Required:**

67R Attack Helicopter Repairer  
One person to assist

**References:**

TM 1-1520-238-CL  
TM 1-1520-238-T-4  
TM 1-1520-238-T-7  
TM 1-1520-238-23

**WARNING**

- When battery is connected, APU will start and run with BATT/EXT PWR switch at OFF position. To prevent accidental APU start, APU circuit breaker in aft avionics bay and APU HOLD circuit breaker on pilot center circuit breaker panel must be open when battery or external electrical power is connected to helicopter. Accidental APU start can cause death or serious injury. If injury occurs, get medical help immediately.
- Jet engine fuel is highly flammable, explosive, and toxic. Work in a well-ventilated area away from open flames. Breathing vapors could cause dizziness. If fuel comes in contact with eyes or skin, flush with water. If injury occurs, seek medical aid.
- When the APU drive shaft is rotating, maintenance personnel should stay clear of the drive shaft/PTO clutch catwalk area while performing maintenance due to potential catastrophic failure of the PTO clutch. Catastrophic failure of the PTO clutch can cause extensive damage to the catwalk area.

1. In aft avionics bay, close **APU** circuit breaker (fig. 15-8).



**NOTE**

Refer to pilot station (fig. 15-6) and CPG station (fig. 15-7) for cockpit configuration and equipment.

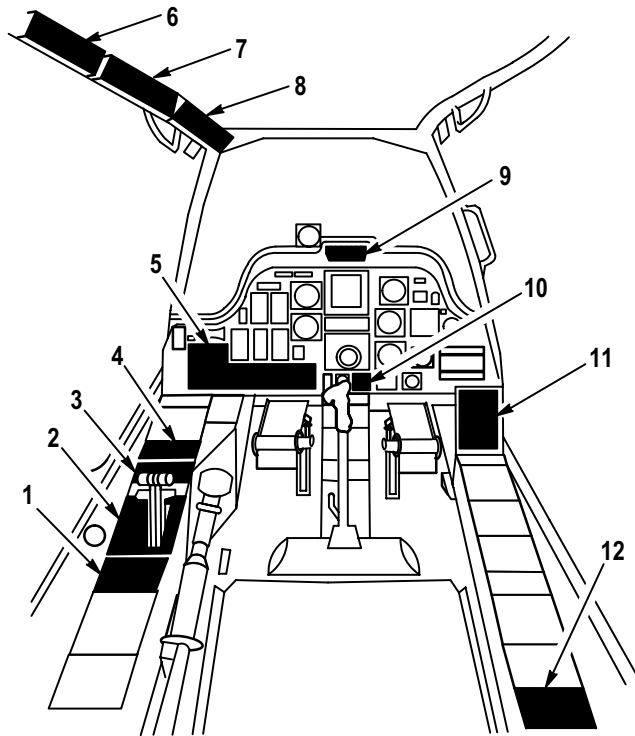

1. PILOT FUEL PANEL
2. PILOT POWER QUADRANT
3. PILOT ELEC PWR PANEL
4. PILOT STORES JETT PANEL
5. PILOT FIRE CONTROL PANEL
6. PILOT AFT CIRCUIT BREAKER PANEL
7. PILOT CENTER CIRCUIT BREAKER PANEL
8. PILOT FORWARD CIRCUIT BREAKER PANEL
9. PILOT MASTER CAUTION / WARNING PANEL
10. PILOT UTIL ACC PSI X 1000 INDICATOR
11. PILOT CAUTION / WARNING PANEL
12. PILOT APU FIRE TEST PANEL

M71-171A

**Figure 15-6. Pilot Station**

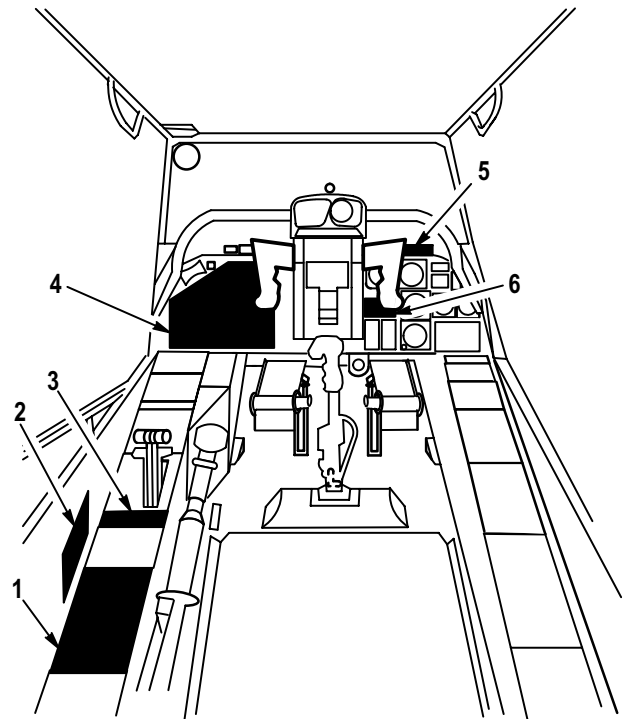

1. CPG CIRCUIT BREAKER PANEL 1
2. CPG CIRCUIT BREAKER PANEL 2
3. CPG FUEL PANEL
4. CPG FIRE CONTROL PANEL
5. CPG MASTER CAUTION / WARNING PANEL
6. CPG SELECTABLE DIGITAL DISPLAY PANEL

M71-170A

**Figure 15-7. CPG Station**

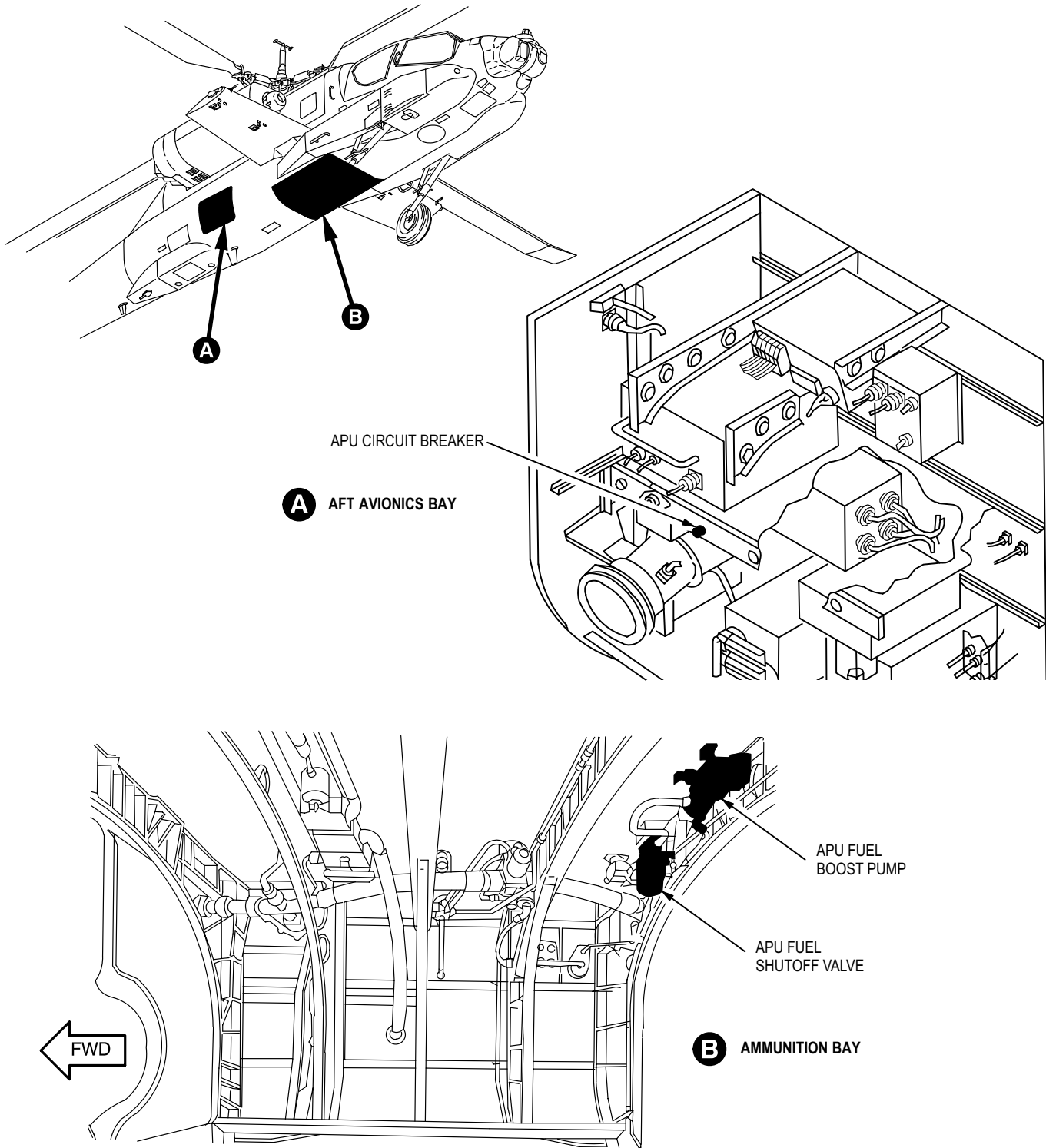

Figure 15-8. APU Circuit Breaker, APU Fuel Boost Pump and APU Fuel Shutoff Valve

M71-165

15-10. AUXILIARY POWER UNIT - POWER UP (cont)

15-10

- On CPG selectable digital display panel (fig. 15-9), set **SELECT** switch to **FUEL QTY LB X 10**.

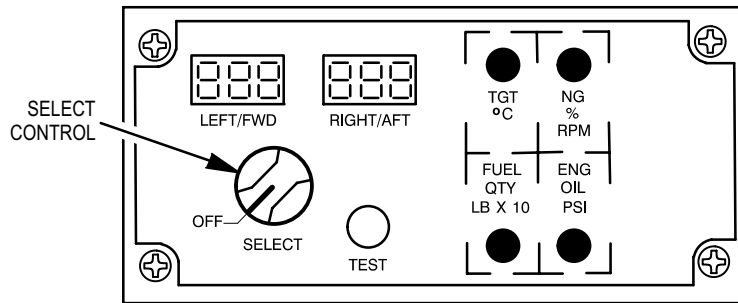

M71-172

Figure 15-9. CPG Selectable Digital Display Panel

- On CPG **FIRE CONTROL** panel (fig. 15-10), set **CPG ARM/SAFE/OFF** switch to **OFF**.

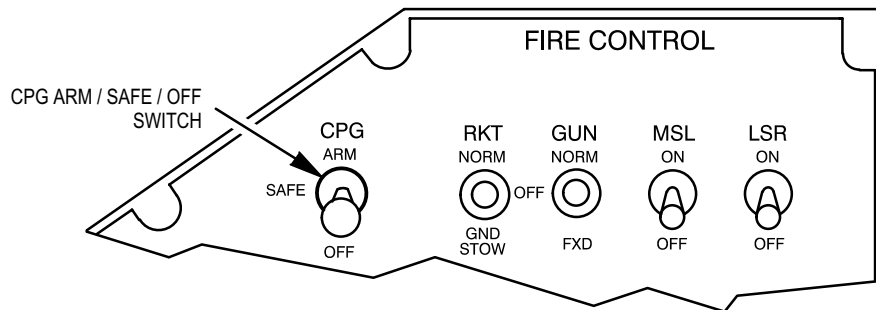

M71-173

Figure 15-10. CPG FIRE CONTROL Panel

- On CPG **FUEL** panel (fig. 15-11), set **ORIDE** switch to **PLT**.

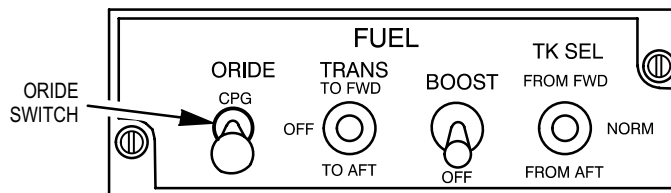

M71-174

Figure 15-11. CPG FUEL Panel

- On CPG circuit breaker panels (fig. 15-12), check that the following circuit breakers are closed.

Circuit Breaker Panel	Circuit Breaker
1	<b>EMERG BATT ICS</b>
1	<b>EMERG BATT ENG INST</b>
2	<b>TADS DC</b>

15-10. AUXILIARY POWER UNIT - POWER UP (cont)

15-10

6. On CPG circuit breaker panels (fig. 15-12), check that the following circuit breakers are open:

Circuit Breaker Panel	Circuit Breaker
2	TADS AC
2	LASER

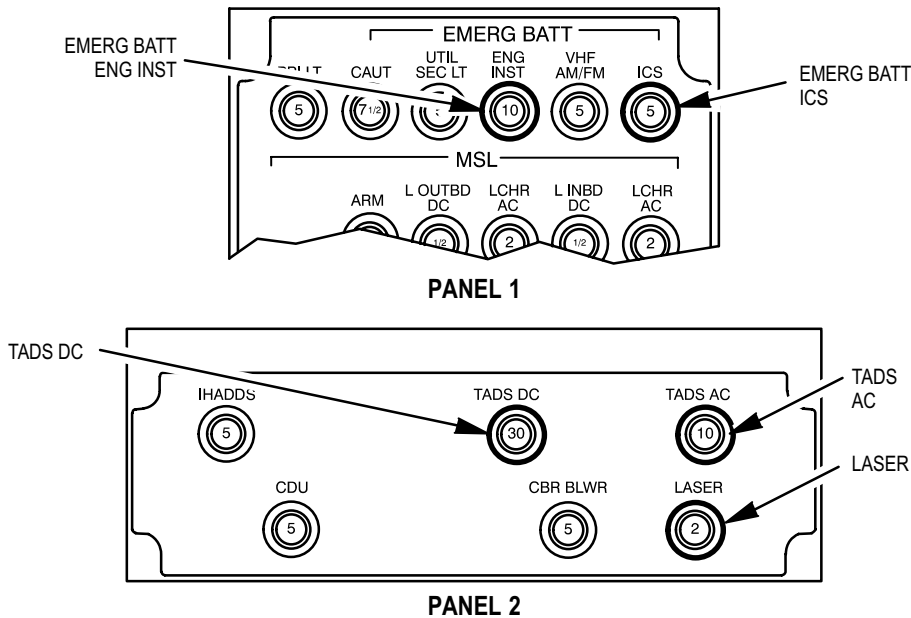

M71-175A

Figure 15-12. CPG Circuit Breaker Panels

7. On pilot FIRE CONTROL panel (fig. 15-13), set MASTER switch to OFF.

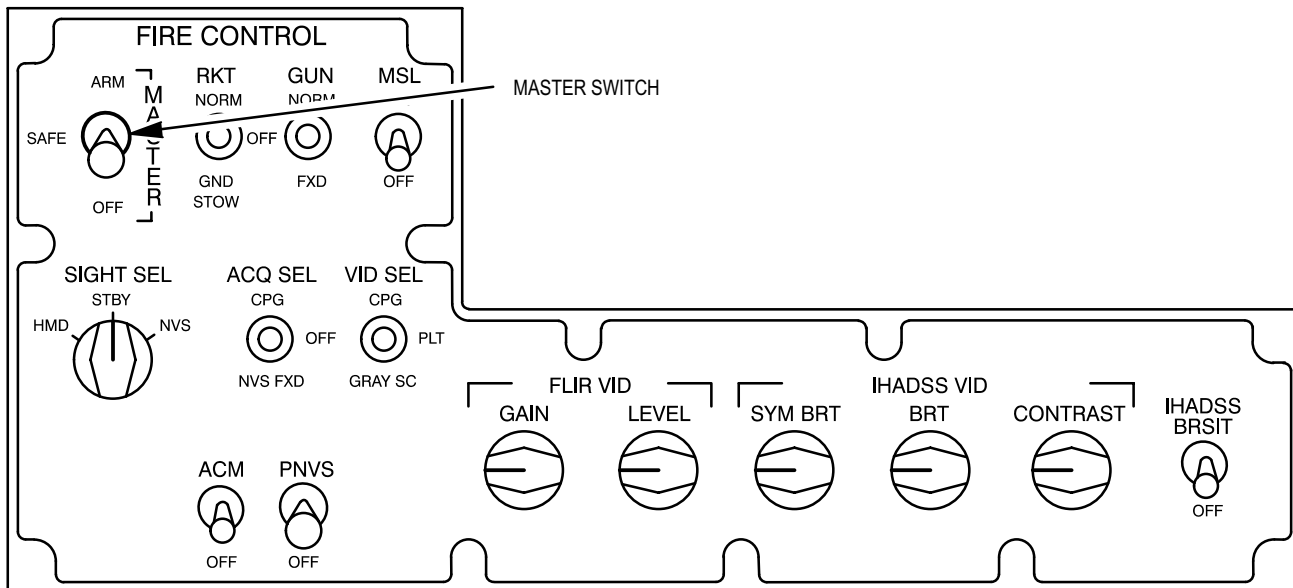

M71-176

Figure 15-13. Pilot FIRE CONTROL Panel

15-10. AUXILIARY POWER UNIT - POWER UP (cont)

15-10

8. On pilot **ELEC PWR** panel (fig. 15-14), set switches as follows:

<u>Switch/Control</u>	<u>Position</u>
<b>BATT/EXT PWR</b>	<b>OFF</b>
<b>GEN 1</b>	<b>OFF</b>
<b>GEN 2</b>	<b>OFF</b>

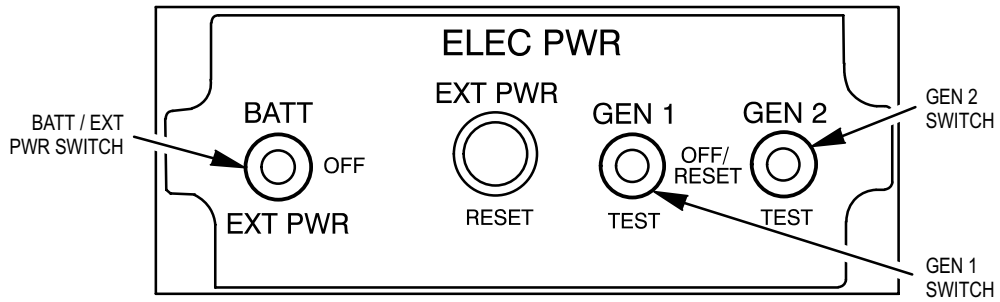

M71-177

Figure 15-14. Pilot BATT/EXT PWR Panel

9. On pilot power quadrant (fig. 15-15), set switches as follows:

<u>Switch/Control</u>	<u>Position</u>
<b>MASTER IGN</b>	<b>OFF</b>
<b>ENG START NO 1</b>	<b>OFF</b>
<b>ENG START NO 2</b>	<b>OFF</b>

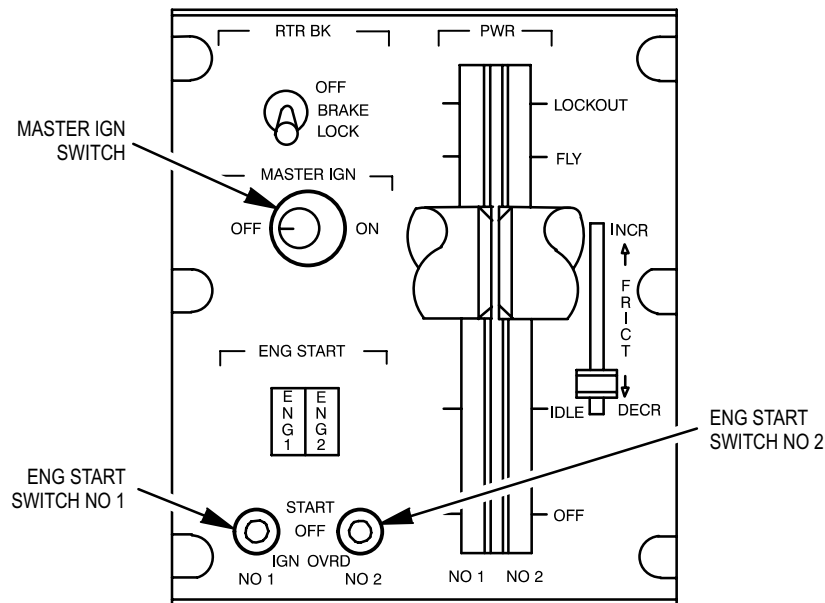

M71-178

Figure 15-15. Pilot Power Quadrant

10. On pilot **STORES JETT** panel (fig. 15-16), ensure all **STORES JETT** switch covers are secured.

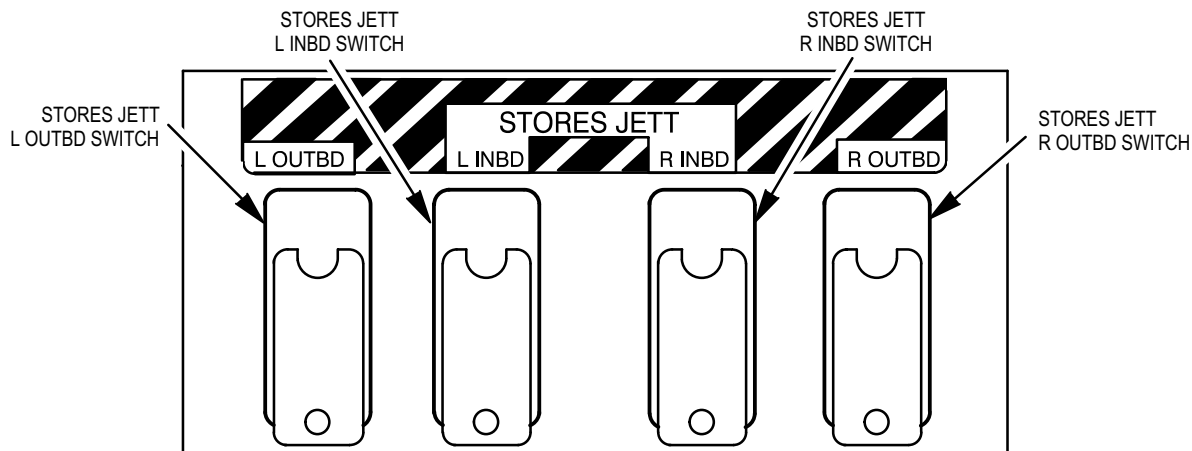

Figure 15-16. Pilot STORES JETT Panel

M71-179

11. On pilot **FUEL** panel (fig. 15-17), set **CROSSFEED** switch to **NORM**. Set all other switches to **OFF**.

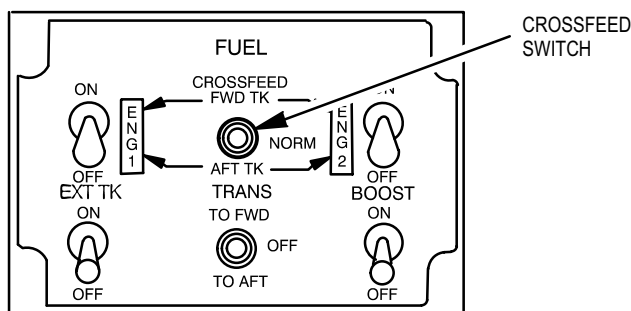

Figure 15-17. Pilot FUEL Panel

M71-180

12. On pilot circuit breaker panels (fig. 15-18), check that following circuit breakers are open:

<u>Circuit Breaker Panel</u>	<u>Circuit Breaker</u>	<u>Circuit Breaker Panel</u>	<u>Circuit Breaker</u>
Forward	<b>MISSION JETT</b>	Center	<b>ENG WARN</b>
Forward	<b>MISSION ARM CONTR</b>	Center	<b>JETT</b>

13. On pilot circuit breaker panels, check that following circuit breakers are closed:

<u>Circuit Breaker Panel</u>	<u>Circuit Breaker</u>	<u>Circuit Breaker Panel</u>	<u>Circuit Breaker</u>
Center	<b>ENG START</b>	Center	<b>COMM ICS</b>
Center	<b>ENG INST</b>	Center	<b>EMERG BATT APU HOLD</b>
Center	<b>FIRE DETR ENG 1</b>	Center	<b>FUEL APU</b>
Center	<b>FIRE DETR APU</b>	Center	<b>FUEL BST</b>
Center	<b>FIRE EXTGH APU</b>	Aft	<b>POWER XFMR RECT 1</b>
Center	<b>LT CAUT</b>	Aft	<b>POWER XFMR RECT 2</b>

14. Have assistant connect battery cable to battery (TM 1-1520-238-23).

15-10. AUXILIARY POWER UNIT - POWER UP (cont)

15-10

15. Apply external power- electrical (TM 1-1520-238-23).

16. Start APU (TM 1-1520-238-CL).

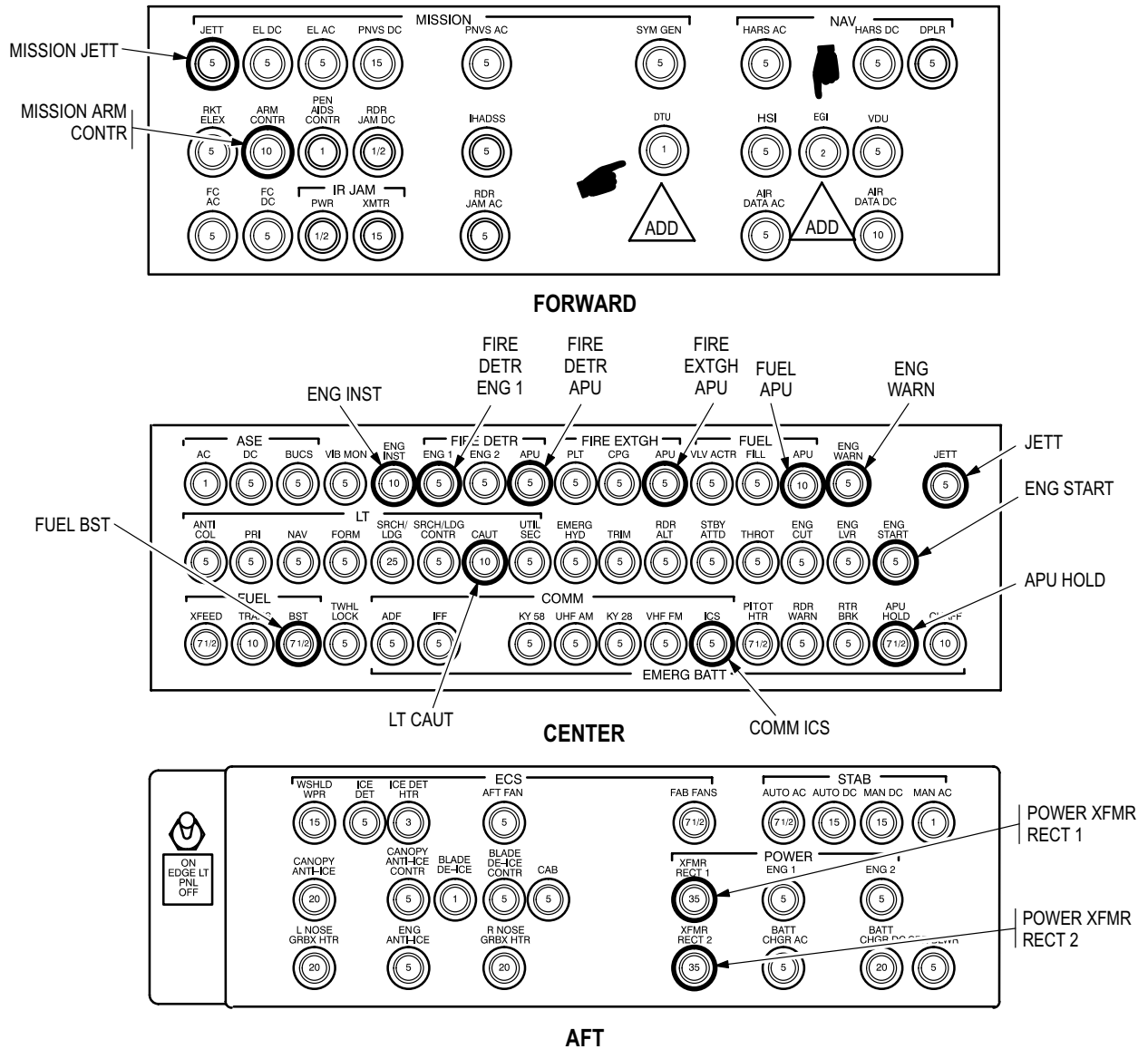

M71-181A

Figure 15-18. Pilot Circuit Breaker Panels

END OF TASK

15-1 1. AUXILIARY POWER UNIT - POWER DOWN

15-1 1

**Tools:**

<u>Nomenclature</u>	<u>Part Number</u>
Tool Kit, Aircraft Mechanic's	SC518099CLA01

**References:**

TM 1-1520-238-T-4
TM 1-1520-238-CL
TM 1-1520-238-23

**Equipment Conditions:**

<u>Ref</u>	<u>Condition</u>
TM 1-1520-238-CL	APU operating
TM 1-1520-238-T-4	Maintenance headset connected

**Personnel Required:**

67R	Attack Helicopter Repairer
	One person to assist

**WARNING**

Jet engine fuel is highly flammable, explosive, and toxic. Work in a well-ventilated area away from open flames. Breathing vapors could cause dizziness. If fuel comes in contact with eyes or skin, flush with water.

**NOTE**

Refer to pilot station (fig. 15-6) and CPG station (fig. 15-7) for cockpit configuration and equipment.

1. Have assistant perform fireguard duties (TM 1-1520-238-23).
2. On pilot **ELEC PWR** panel (fig. 15-14), set **GEN 1** and **GEN 2** switches to **OFF/RESET**.
3. On pilot **APU** fire test panel (fig. 15-19), set **START/RUN/OFF** switch to **OFF**.

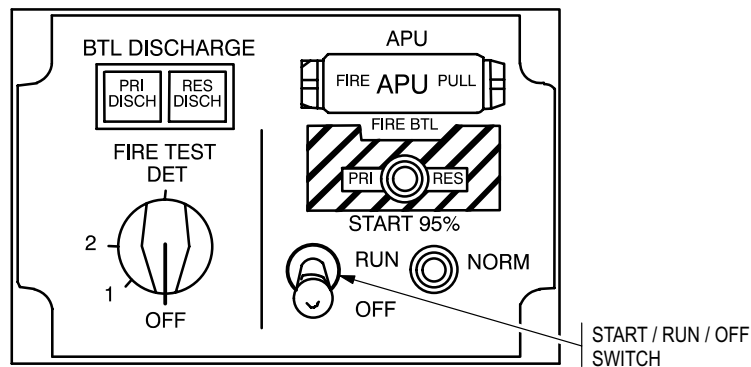

M71-184A

Figure 15-19. Pilot APU Fire Test Panel



**WARNING**

When battery is connected, APU will make a start attempt and run with BATT/EXT PWR switch at OFF position. To prevent accidental APU start attempt and run, APU circuit breaker in aft avionics bay and APU HOLD circuit breaker on pilot center circuit breaker panel must be open when battery or external electrical power is connected to helicopter. Accidental APU start can cause death or serious injury. If injury occurs, get medical help immediately.

4. After APU stops rotating, set **BATT/EXT PWR** switch on pilot **ELEC PWR** panel to **OFF**.
5. Disconnect maintenance headset (TM 1-1520-238-T-4).
6. Safe helicopter (TM 1-1520-238-23).

END OF TASK

15-1 1A. AUXILIARY POWER UNIT POWER TAKE OFF (PTO) CLUTCH - VIBRATION CHECK

15-1 1A

**Tools:**

<u>Nomenclature</u>	<u>Part Number</u>
Tool Kit, Aircraft Mechanic's	SC518099CLA01
Aviation Vibration Analysis Test Set	6625-01-282-3746
Helicopter Rotor Head Balance and Blade Track Run Test Equipment	4920-01-180-7610

**References:**

- TM 1-1520-238-10
- TM 1-1520-238-MTF
- TM 1-1520-238-T-4
- TM 1-1520-238-23

**Personnel Required:**

- 67R Attack Helicopter Repairer  
One person to assist
- 152FG Pilot
- 152FG Maintenance Test Pilot
- 67R3T Inspector

**Equipment Conditions:**

<u>Ref</u>	<u>Condition</u>
TM 1-1520-238-T-4	Maintenance headset connected

**NOTE**

- Refer to pilot station (fig. 15-6) and CPG station (fig. 15-7) for crewstation configuration and equipment.
- The vibration check defined by these procedures should be performed at every 250 hour phase inspection and whenever an APU/PTC is installed.
- If this check is being performed following a 250 hour phase inspection as a part of rotor track and balance testing using the Aviation Vibration Analyzer (AVA), proceed to step 2.

**1. AVA BASIC KIT INSTALLATION**

- a. Remove AVA equipment from transport case. Check for possible damaged equipment and frayed cables.

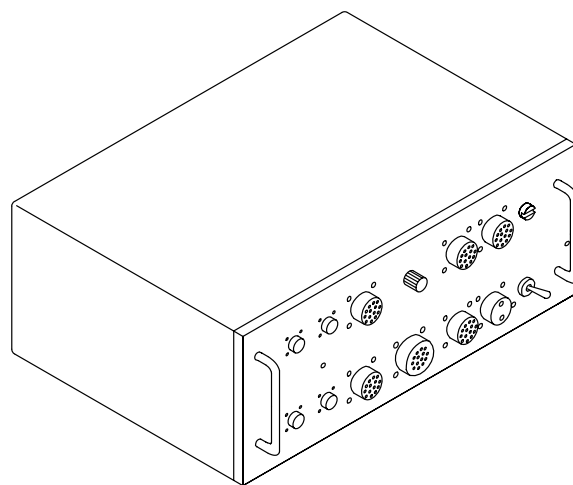

M71-319

**Figure 15-19.a. DAU**

**15-1 1A. AUXILIARY POWER UNIT POWER TAKE OFF (PTO) CLUTCH - VIBRATION CHECK (cont) 15-1 1A**

- c. Place DAU on outboard side of CPG left armor plate (fig 15-19.b) with connectors facing up and on/off switch forward, and secure DAU using canvas straps and D-rings. Ensure that DAU is OFF.

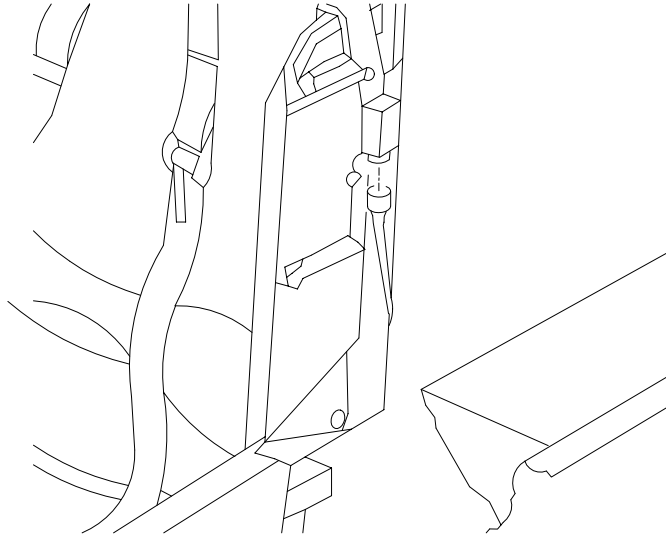

M71-320

**Figure 15-19.b. DAU on CPG Left Armor Plate**

- d. Connect AH-64-to-DAU cable (29304600) to SPU.
- e. Route AH-64-to-DAU cable (fig 15-19.c) under the CPG seat and around to the DAU.

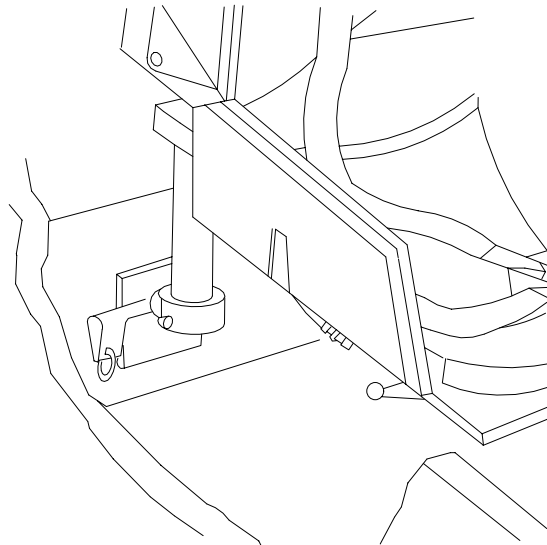

M71-322

**Figure 15-19.c. AH64-to-DAU Cable Under CPG Seat to DAU**

**15-1 1A. AUXILIARY POWER UNIT POWER TAKE OFF (PTO) CLUTCH - VIBRATION CHECK (cont) 15-1 1A**

- f. Connect AH64-to-DAU cable (fig 15-19.d) 28Vdc termination to the DAU receptacle marked **28 Vdc**. (It is not necessary to connect the two other cable termination (multichannel and tachometer) to the corresponding DAU ports.)
- g. Place CADU in aircraft. Connect CADU-to-DAU cable (29325601) to CADU and to DAU receptacle marked "**CADU**".

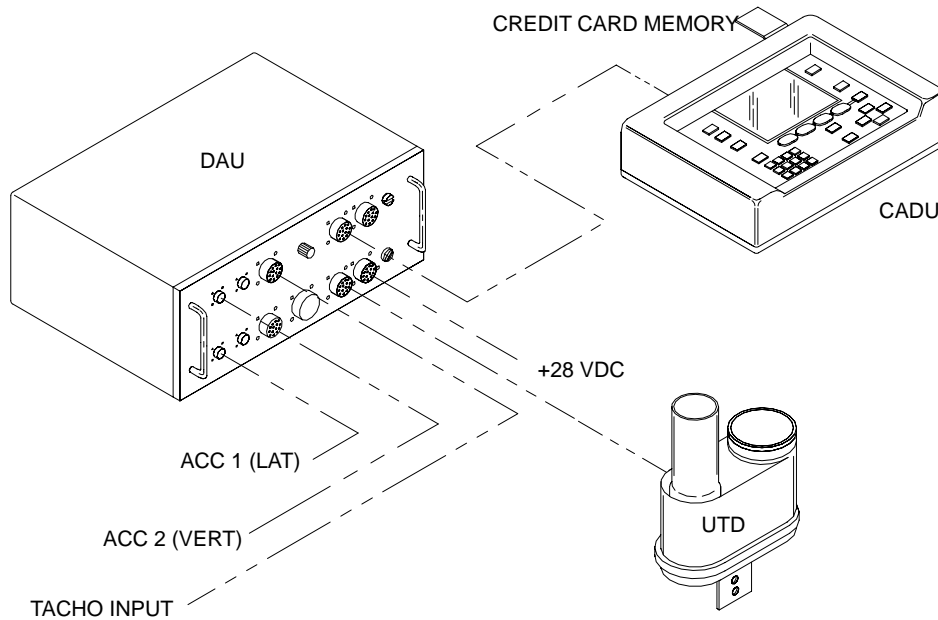

M71-326

**Figure 15-19.d. CADU to DAU**

**2. APU CLUTCH ACCELEROMETER INSTALLATION**

- a. Install the accelerometer bracket (fig 15-19.e) part number 7-562117009-1 using existing existing PTO clutch output housing bolt, part number MS9556-05, in the 8 o'clock position looking aft, on the output section of the APU clutch. Mount the bracket so that when accelerometer is installed it is oriented radially to the clutch centerline.
- b. Torque 8 o'clock bolt to **50 INCH POUNDS**.

15-1 1A. AUXILIARY POWER UNIT POWER TAKE OFF (PTO) CLUTCH - VIBRATION CHECK (cont) 15-1 1A

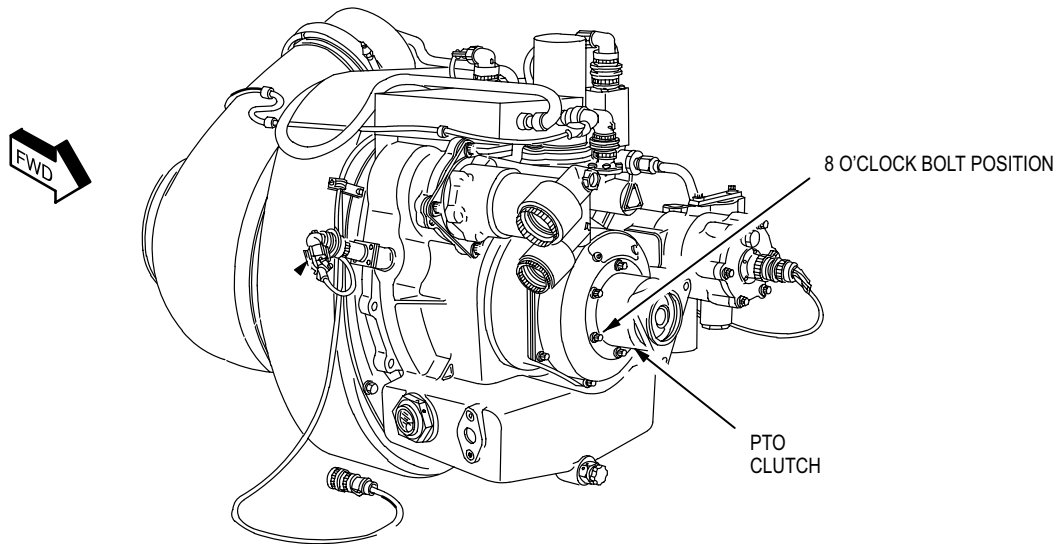

M71-324

Figure 15-19.e. 8 O'Clock Bolt Position

- c. Attach accelerometer (fig 15-19.f) (P/N 28110900) from AVA basic kit to the mounting bracket. Ensure that accelerometer is oriented radially to the clutch centerline.
- b. Torque accelerometer to **40 INCH POUNDS**.
- e. Connect AVA 50 ft. accelerometer cable (P/N 29105600) to the clutch accelerometer.

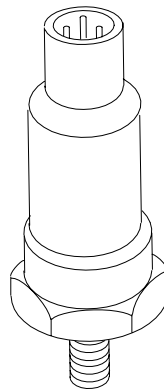

M71-323

Figure 15-19.f. Accelerometer

15-1 1A. AUXILIARY POWER UNIT POWER TAKE OFF (PTO) CLUTCH - VIBRATION CHECK (cont) 15-1 1A



Ensure cable is securely tied down along its length to prevent entanglement with PTO shaft or other rotating machinery.

- f. Route accelerometer cable up through hole in APU enclosure (#2 Engine fire extinguisher tube hole), up to W118 wire bundle, then forward and out the R190 panel to the aircraft exterior and in through the CPG door to the DAU mounted in the CPG station.
- g. Connect accelerometer cable to DAU accelerometer port **ACC3** (fig 15-19.h).

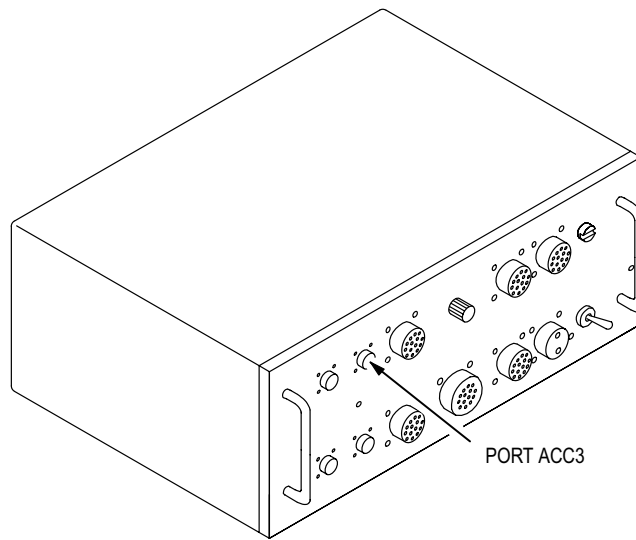

M71-328

Figure 15-19.h. DAU Accelerometer Port ACC3

15-1 1A. AUXILIARY POWER UNIT POWER TAKE OFF (PTO) CLUTCH - VIBRATION CHECK (cont) 15-1 1A

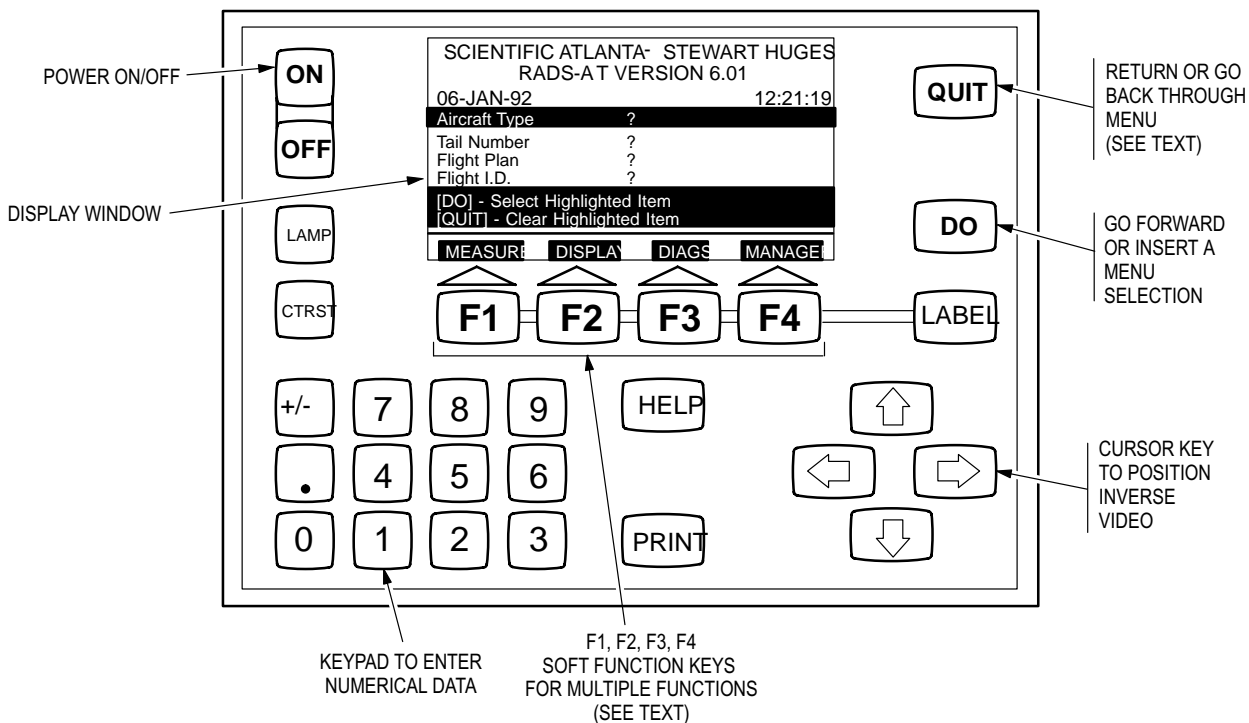

M71-0329

Figure 5-19.i. CADU Display and Keypad

3. ACQUIRE PTO VIBRATION DATA

NOTE

- If this procedure is being performed as a part of rotor track and balance, these measurements can be acquired during the same ground runs required for rotor track and balance.
- These measurements must be acquired on the ground when APU is OFF and rotors are operated at 100% (power lever(s) at FLY) at flat pitch.

- a. Start APU (TM 1-1520-238-10).
- b. On DAU, set power switch to **ON**.
- c. On DAU, verify green light above DAU power switch is illuminated.
- d. On CADU (fig 5-19.i), set power to **ON**.
- e. On CADU select **AH64** aircraft type and press **DO**.
- f. Enter the aircraft tail number and press **DO**.
- g. On CADU, select Flight Plan **PTCVIB** and press **DO**.
- h. On CADU, enter measure menu by selecting **F1** from main menu.

NOTE

Either single or dual engine operation is acceptable.

- i. Perform normal engine start up (TM 1-1520-238-MTF).
- j. Operate main engine(s) and main rotor at 100% Nr (power lever(s) (fig 15-19.j) at **FLY**).

15-1 1A. AUXILIARY POWER UNIT POWER TAKE OFF (PTO) CLUTCH - VIBRATION CHECK (cont) 15-1 1A

- k. Shut down APU (TM 1-1520-238-10).

**NOTE**

**Allow one minute following APU OFF selection for APU to wind down prior to initiating measurement.**

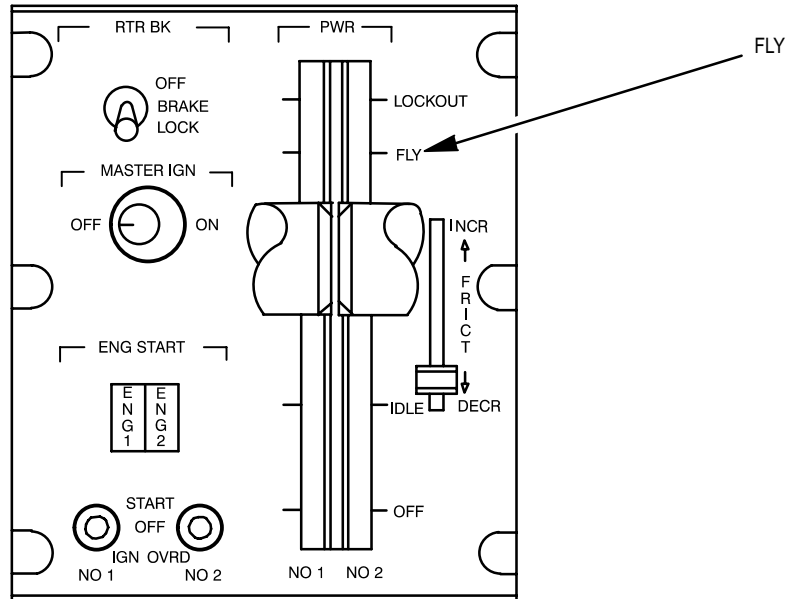

M71-330

**Figure 15-19.j. Pilot Power Quadrant**

- l. Verify that CADU (fig 5-19.i) is on measurement screen and Test State **PTCVIB** is highlighted.
- m. Press **DO** twice to initiate PTO clutch vibration data acquisition.

**4. REVIEW AND RECORD PTO VIBRATION AMPLITUDE**

- a. When the AVA has finished its measurement of the **PTCVIB** test state, press **DO** on **FINISH**, and press **DO** on **DIAGNOSTICS**.
- b. The **LIMITS** page will appear: either the **MEASUREMENTS ARE WITHIN SPECIFIED LIMITS** will appear, or **MEASURED** vibration level will be displayed with specific **LIMIT**. Press **UP ARROW** to view the measured vibration level.

**NOTE**

- Ignore **PTCVIB NEW P/N 3617950-1 LIMIT 1.00** message on **LIMITS** page. This applies only to new clutch P/N 3617950-1.
  - The **PTCVIB OLD P/N 3886000-5** message applies to both apu clutch part numbers **3886000-5** and **3886000-5-1**.
- c. If vibration level is above 2.0 IPS, proceed to step i.
  - d. If vibration level is at or below 2.0 IPS, record vibration measurement.
  - e. Perform normal aircraft shutdown (TM 1-1520-238-10).
  - f. Disconnect and remove AVA equipment and PTO clutch accelerometer (fig 15-19.e) and mounting bracket.



**15-1 1A. AUXILIARY POWER UNIT POWER TAKE OFF (PTO) CLUTCH - VIBRATION CHECK (cont) 15-1 1A**

- g. Install PTO clutch bolt (fig 15-19.k) (P/N MS9556-05) located at the 8 o'clock position and torque to **50 INCH POUNDS**.
- h. Verify clutch bearing retainer output housing bolts and housing bolts are torqued to **50 INCH POUNDS**.
- i. Perform normal aircraft shutdown (TM 1-1520-238-10).
- j. Inspect PTO clutch installation and PTO clutch accelerometer installation.
- k. Verify PTO clutch is installed properly.
  - l. Verify PTO clutch accelerometer and bracket are installed properly and securely.
- m. Correct any discrepancies and recheck vibration level.
- n. If vibration from PTO accelerometer is above 2.0 ips, remove and replace APU PTO clutch (TM 1-1520-238-23).
- o. If vibration level is below 2.0 ips, record vibration measurement and perform steps e through h.

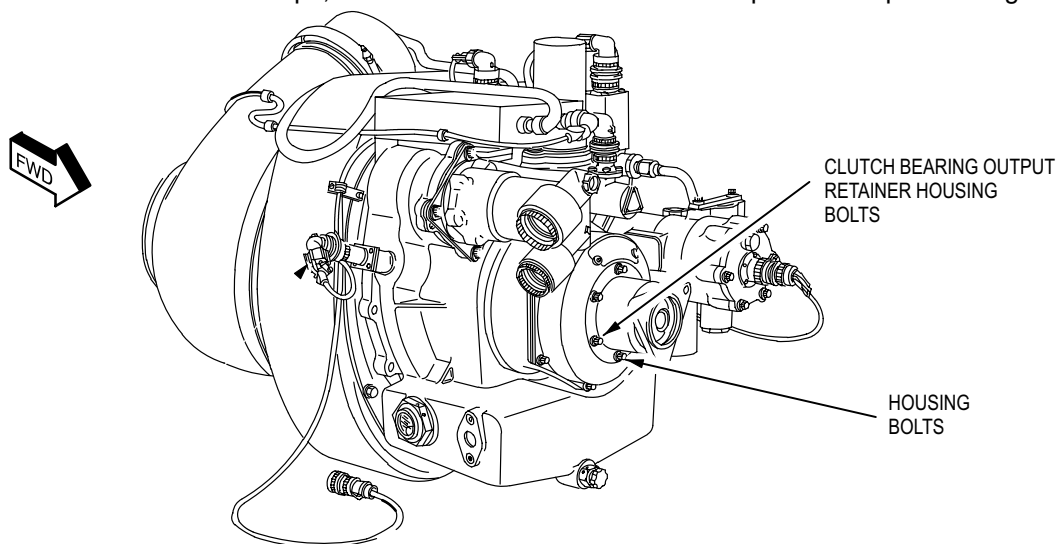

M71-331

**Figure 15-19.k. Clutch Bearing Output Retainer Housing Bolts and Housing Bolts.**

END OF TASK

15-12. AUXILIARY POWER UNIT - MAINTENANCE OPERATIONAL CHECK

15-12

**Tools:**

<u>Nomenclature</u>	<u>Part Number</u>
Tool Kit, Aircraft Mechanic's	SC518099CLA01

**Equipment Conditions:**

<u>Ref</u>	<u>Condition</u>
TM 1-1520-238-T-6	Pilot station lighting at full bright
TM 1-1520-238-23	APU upper enclosure removed Access provisions - B200 door removed, L325, T250L, T250R, T290L and T290R doors open
TM 9-1090-208-23-1	Ammunition storage magazine removed (If APU fuel shutoff valve is suspected defective.)

**Personnel Required:**

67R Attack Helicopter Repairer  
One person to assist

**References:**

TM 1-1520-238-CL  
TM 1-1520-238-T-1  
TM 1-1520-238-T-3  
TM 1-1520-238-T-5  
TM 1-1520-238-23  
TM 9-1090-208-23-1

**WARNING**

- When battery is connected, APU will attempt to start and run with BATT/EXT PWR switch at OFF position. To prevent accidental APU start, APU circuit breaker in aft avionics bay and APU HOLD circuit breaker on pilot center circuit breaker panel shall be open when battery or external electrical power is connected to helicopter. Accidental APU start can cause death or serious injury. If injury occurs, get medical help immediately.
- Jet engine fuel is highly flammable, explosive, and toxic. Work in a well-ventilated area away from open flames. Breathing vapors could cause dizziness. If fuel comes in contact with eyes or skin, flush with water.
- When the APU drive shaft is rotating, maintenance personnel should stay clear of the drive shaft/PTO clutch catwalk area while performing maintenance due to potential catastrophic failure of the PTO clutch. Catastrophic failure of the PTO clutch can cause extensive damage to the catwalk area.

**NOTE**

- Refer to pilot station (fig. 15-6) and CPG station (fig. 15-7) for cockpit configuration and equipment.
- If referenced out of one paragraph or volume into another for additional troubleshooting, upon completion of the task return to the maintenance operational check for the original paragraph or volume.
- Perform the APU FUEL SYSTEM PRIMING (TM 1-1520-238-23) task if the APU fuel supply has been interrupted for the following maintenance tasks: APU and/or related fuel supply component removals (APU fuel pump, shutoff valve or fuel supply lines to and from the APU fuel pump or shutoff valve).

1. Ensure that foreign object damage (FOD) is not present around aft deck area (fig. 15-20) or in APU exhaust duct.

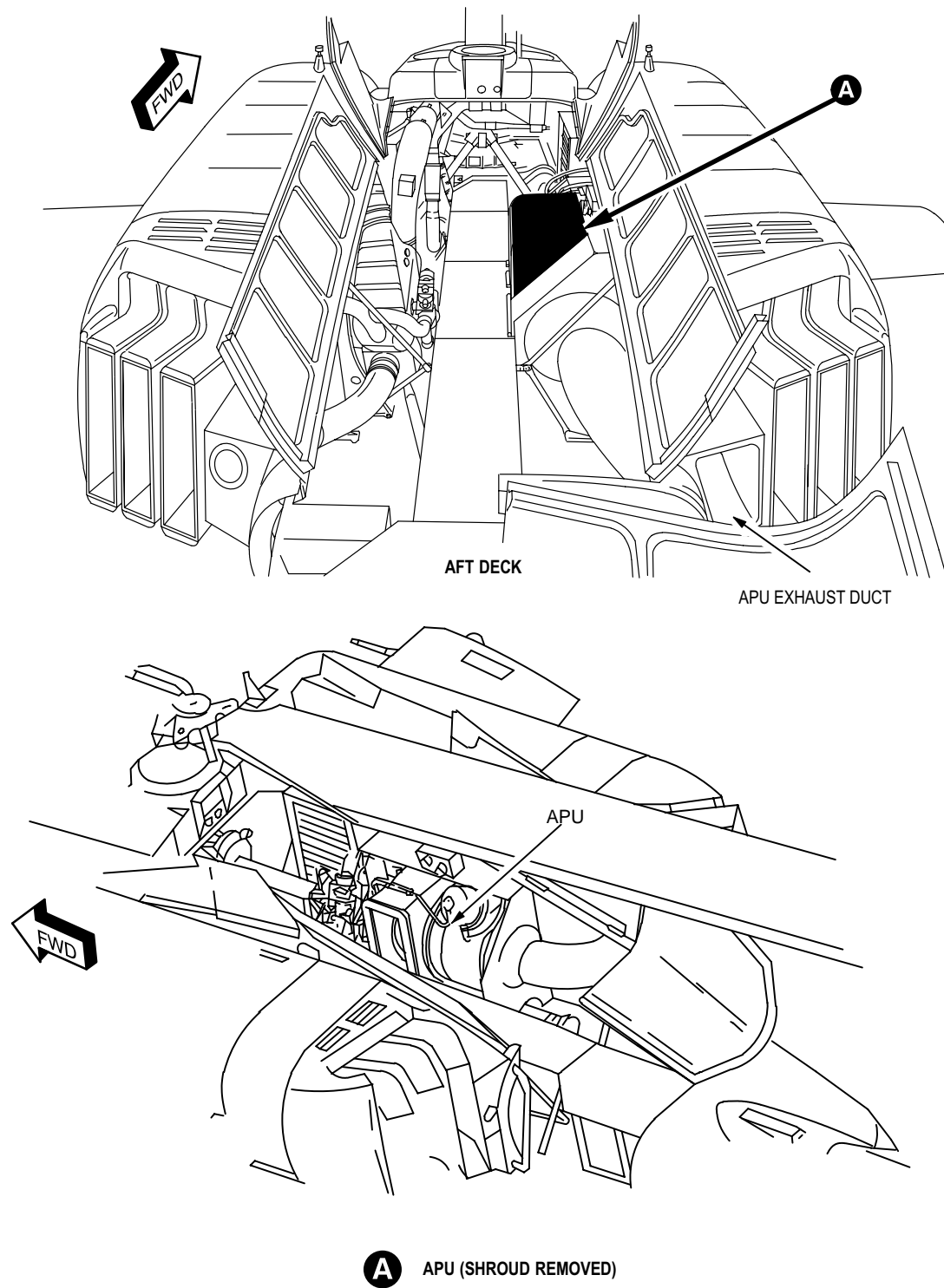

**A** APU (SHROUD REMOVED)

M71-185

Figure 15-20. APU and APU Exhaust Duct

2. Complete the maintenance operational check as follows:

Task	Result
a. In aft avionics bay (fig. 15-8), check that <b>APU</b> circuit breaker is closed.	If <b>APU</b> circuit breaker does not stay closed, go to paragraph 15-34.

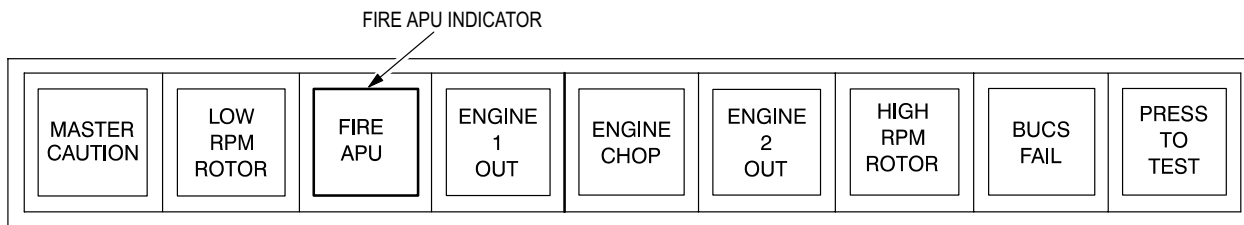

M71-214

**Figure 15-21. Master Caution/Warning Panel**

- |   |  |
|---|--|
| <p>b. On pilot center circuit breaker panel (fig. 15-18), check that <b>APU HOLD</b> circuit breaker is closed.</p>   | <p>If <b>APU HOLD</b> circuit breaker does not stay closed, go to paragraph 15-36.</p>   |
| <p>c. On pilot <b>APU</b> fire test panel (fig. 15-19), set and hold <b>FIRE TEST DET</b> selector to <b>1</b>. On pilot and CPG master caution/warning panels (fig. 15-21), check that <b>FIRE APU</b> indicators are lighted. On pilot <b>APU</b> fire test panel, check that <b>APU FIRE PULL</b> handle is lighted.</p> | <p>If any of the indicators called out are not lighted, replace lamps (TM 1-1520-238-23). If lamps still do not light, go to paragraph 12-123 to troubleshoot APU fire detection.</p>      |
| <p>d. On pilot <b>APU</b> fire test panel, set and hold <b>FIRE TEST DET</b> selector to <b>2</b>. On pilot and CPG master caution/warning panels, check that <b>FIRE APU</b> indicators are lighted. On pilot <b>APU</b> fire test panel, check that <b>APU FIRE PULL</b> handle is lighted.</p>                           | <p>If any of the indicators called out are not lighted, replace lamps (TM 1-1520-238-23). If lamps still do not light, go to paragraph 12-112 to troubleshoot engine 2 fire detection.</p> |

**NOTE**

**If fuel leakage is present in the ammunition bay area or the APU fuel shutoff valve may be defective, proceed to step f. if not, proceed to step j.**

15-12. AUXILIARY POWER UNIT - MAINTENANCE OPERATIONAL CHECK (cont)

15-12

Task	Result
<p>e. On pilot <b>APU</b> fire test panel (fig. 15-19), set <b>START/RUN/OFF</b> switch to <b>RUN</b>. Verify with assistant through ICS that APU fuel shutoff valve (fig. 15-8) is open, APU boost pump is operating, and no fuel leakage is present.</p>	<p>If <b>FUEL BST</b> circuit breaker does not stay closed, go to paragraph 15-31.</p> <p>If <b>FUEL APU</b> circuit breaker does not stay closed, go to paragraph 15-32.</p> <p>If <b>APU HOLD</b> circuit breaker does not stay closed, go to paragraph 15-33.</p> <p>If <b>APU</b> circuit breaker does not stay closed, go to paragraph 15-34.</p> <p>If APU fuel shutoff valve does not open with <b>START/RUN/OFF</b> switch set to <b>RUN</b>, go to paragraph 15-23.</p> <p>If APU boost pump does not operate with <b>START/RUN/OFF</b> switch set to <b>RUN</b>, go to paragraph 15-24.</p> <p>If fuel leakage is present, replace components (TM 1-1520-238-23).</p>



**Make sure that all FIRE BTL switches are in neutral (center) position to prevent bottles from discharging.**

<p>f. Advise assistant through ICS in ammunition bay to watch APU fuel shutoff valve. On pilot <b>APU</b> fire test panel, pull <b>APU FIRE PULL</b> handle. Check that APU fuel shutoff valve closes.</p>	<p>If APU fuel shutoff valve does not close with <b>APU FIRE PULL</b> handle pulled, go to paragraph 15-25.</p>
<p>g. Push <b>APU FIRE PULL</b> handle. Check that APU fuel shutoff valve operates.</p>	<p>If APU fuel shutoff valve does not open, go to paragraph 15-23.</p>
<p>h. On pilot <b>APU</b> fire test panel, set <b>START/RUN/OFF</b> switch to <b>OFF</b>. Check that APU fuel shutoff valve is closed and APU fuel boost pump is not operating.</p>	<p>If APU fuel shutoff valve does not close with <b>START/RUN/OFF</b> switch set to <b>OFF</b>, go to paragraph 15-26.</p>
<p>i. Verify pilot <b>UTIL ACC PSI X 1000</b> indicator (fig. 15-22) indicates <b>3</b>(3000 PSI).</p>	<p>If <b>APU HOLD</b> circuit breaker does not stay closed, go to paragraph 15-36.</p> <p>If <b>UTIL ACC PSI X 1000</b> indicator does not indicate <b>3</b>(3000 PSI), refer to TM 1-1520-238-T-5 to troubleshoot utility hydraulic system.</p>

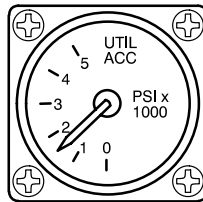

M71-187

Figure 15-22. Pilot UTIL ACC PSI X 1000 Indicator



- Use of the 95%/NORM switch is prohibited at ambient temperature above 0° F (-18° C). Steps/results calling for 95%/NORM switch actuation are to be performed only when ambient temperature is below 0° F (-18° C). If ambient temperature exceeds 0° F (-18° C), proceed to step t.
- APU starts. After a fault or aborted start, wait 30 seconds after compressor has stopped before attempting another start. After two consecutive start attempts, wait 20 minutes before third attempt. No more than three start attempts are permitted in one hour.

Task	Result
j. Ensure the ambient temperature is below 0° F (-18° C).	
k. Have assistant check vicinity of helicopter and warn any personnel that APU is about to start. Wait for assistant to advise CLEAR FOR APU START through ICS.	
l. Have assistant take a position 10 feet to side of engine 2 exhaust (fig. 15-23), with fire extinguisher.	
<b>NOTE</b>	
<b>The APU may be started with or without an AGPU.</b>	
m. On pilot <b>APU</b> fire test panel (fig. 15-19), set <b>START/RUN/OFF</b> switch to <b>RUN</b> .	
n. On pilot <b>APU</b> fire test panel set and hold <b>95%/NORM</b> switch to <b>95%</b> and start APU (TM 1-1520-238-23). Check that APU starts and runs.	<p>If APU start sequence does not begin, go to paragraph 15-14.</p> <p>If APU does not start, go to paragraph 15-35.</p>

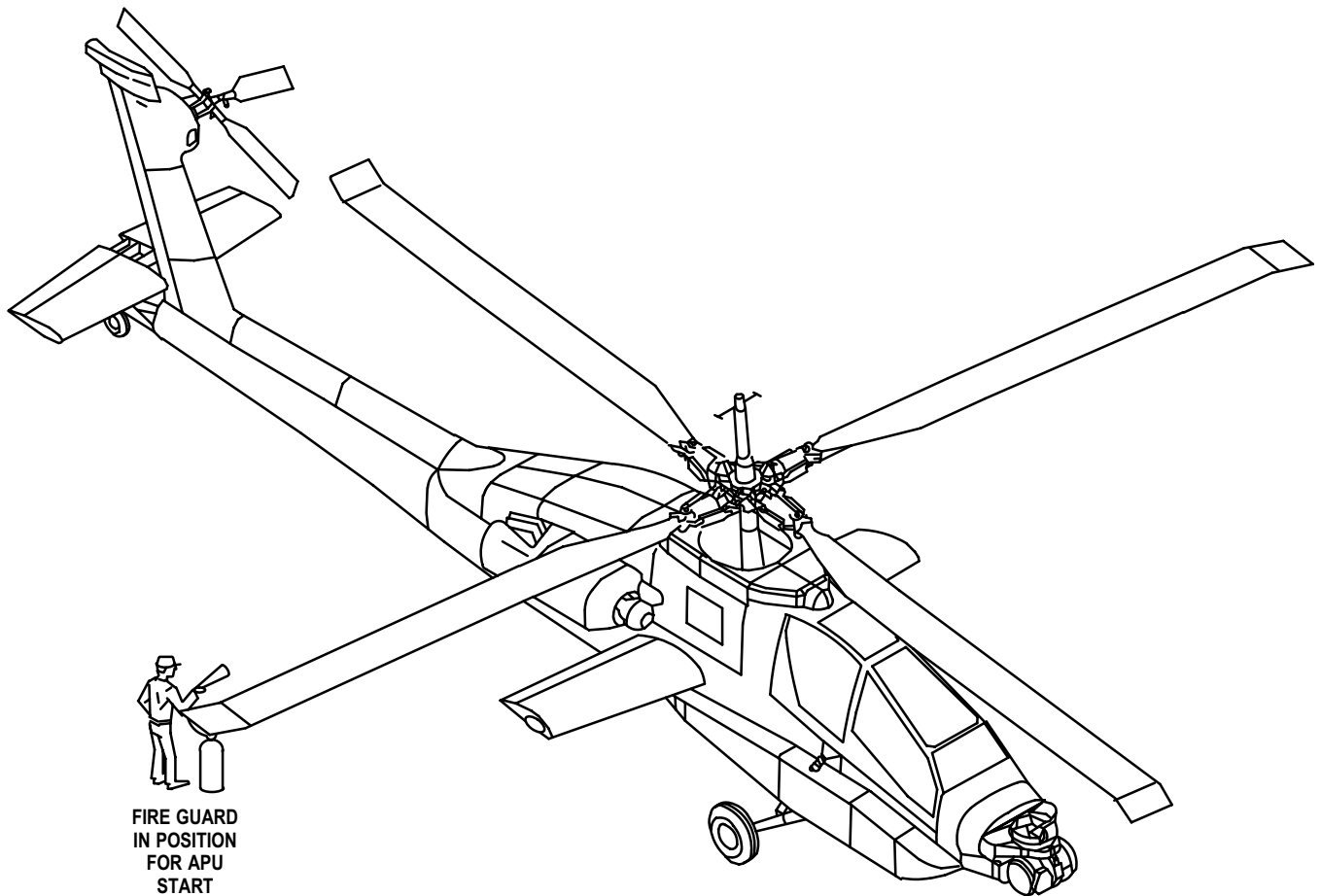

M71-186

Figure 15-23. Fire Guard Position

Task	Result
<p>o. On pilot caution/warning panel (fig. 15-24), check <b>APU FAIL</b> and <b>APU ON</b> indicators. Check that <b>APU FAIL</b> indicator is not lighted 5 seconds after APU start sequence begins. Check that <b>APU ON</b> indicator is lighted when APU speed reaches 95% rpm.</p>	<p>If <b>APU ON</b> indicator is not lighted 60 seconds after APU start, replace lamps (TM 1-1520-238-23). If lamp still does not light, go to paragraph 15-27.</p>
<p>p. On pilot caution/warning panel, check that <b>PRI HYD PSI</b>, <b>UTIL HYD PSI</b>, and <b>SHAFT DRIVEN COMP</b> indicators are lighted.</p>	<p>If <b>PRI HYD PSI</b>, <b>UTIL HYD PSI</b>, and <b>SHAFT DRIVEN COMP</b> indicators are not lighted with <b>95%/NORM</b> switch set to <b>95%</b>, replace lamps (TM 1-1520-238-23). If lamps still do not light, go to paragraph 15-28.</p>

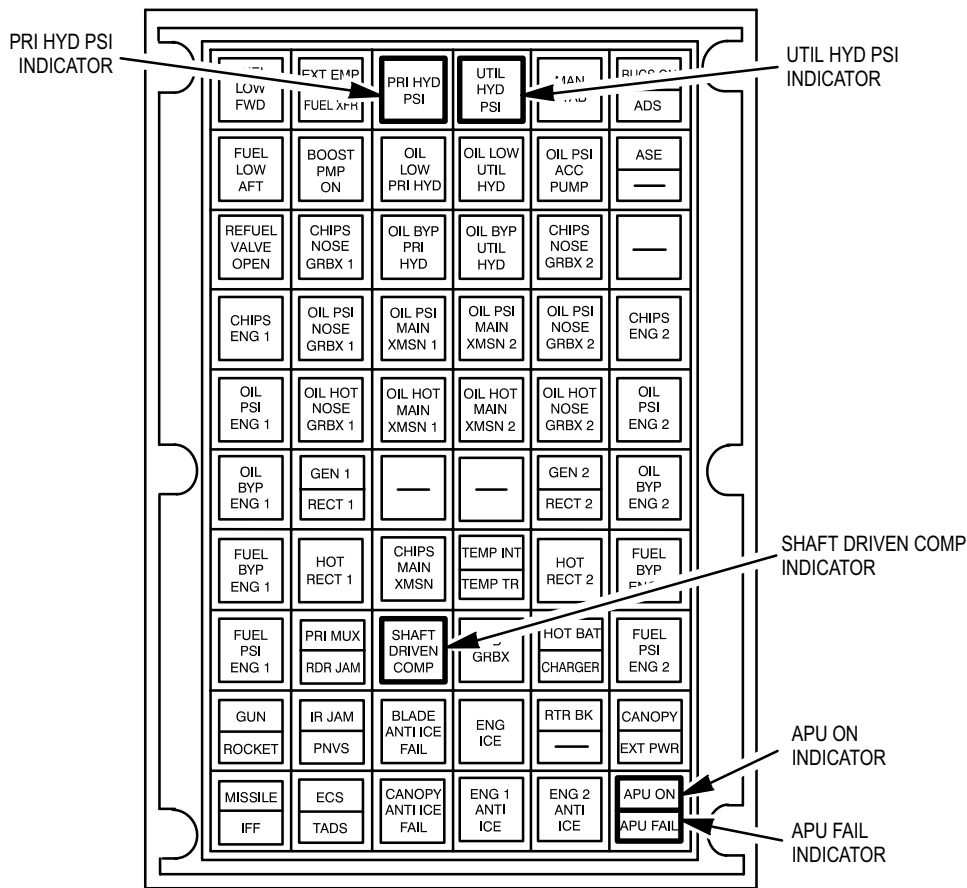

Figure 15-24. Pilot Caution/Warning Panel

M71-188

Task	Result
<p>q. On pilot <b>APU</b> fire test panel (fig. 15-19), when <b>APU ON</b> indicator lights, release <b>95%/NORM</b> switch. Check that the <b>95%/NORM</b> switch returns to <b>NORM</b> and <b>PRI HYD PSI</b>, <b>UTIL HYD PSI</b>, and <b>SHAFT DRIVEN COMP</b> indicators are not lighted.</p>	<p>If <b>PRI HYD PSI</b>, <b>UTIL HYD PSI</b>, and <b>SHAFT DRIVEN COMP</b> indicators are lighted with <b>95%/NORM</b> switch set to <b>NORM</b>, go to paragraph 15-29.</p>
<p>r. Continue operating APU until <b>UTIL ACC PSI X 1000</b> indicator indicates <b>3000 PSI</b>.</p>	<p>If <b>UTIL ACC PSI X 1000</b> indicator does not indicate <b>3000 PSI</b> with APU operating, refer to TM 1-1520-238-T-5 to troubleshoot utility hydraulic system.</p>
<p>s. On pilot <b>APU</b> fire test panel, set <b>START/RUN/OFF</b> switch to <b>OFF</b>.</p>	



15-12. AUXILIARY POWER UNIT - MAINTENANCE OPERATIONAL CHECK (cont)

15-12

Task	Result
------	--------



**APU starts. After a fault or aborted start, wait 30 seconds after compressor has stopped before attempting another start. After two consecutive start attempts wait 20 minutes before third attempt. No more than three start attempts are permitted in one hour.**

**NOTE**

**If a discrepancy is noted during the FD/LS check, perform corrective action indicated in TM 1-1520-238-T-1. If the discrepancy still exists after performing the corrective action required, refer to the following listed failure symptoms and perform troubleshooting.**

- t. Ensure 20 minute cool down period and perform APU FD/LS check (TM 1-1520-238-T-1).

If APU start sequence does not begin, go to paragraph 15-14.

If APU does not start and **APU NO-GO UNDERSPEED** appears on heads out display (HOD), refer to TM 1-1520-238-T-3, APU Multiplex Read Codes, and perform troubleshooting. Then if no fault is found, go to paragraph 15-15.

If APU does not run and **APU NO-GO OVERTEMP** appears on HOD, refer to TM 1-1520-238-T-3, APU Multiplex Read Codes, and perform troubleshooting. Then if no fault is found, go to paragraph 15-16.

If APU does not run and **APU NO-GO UNDERSPEED** appears on HOD, refer to TM 1-1520-238-T-3, APU Multiplex Read Codes, and perform troubleshooting. Then if no fault is found, go to paragraph 15-17.

If APU runs and **APU NO-GO UNDERSPEED** appears on HOD and PTO clutch does not engage, refer to TM 1-1520-238-T-3, APU Multiplex Read Codes, and perform troubleshooting. Then if no fault is found, go to paragraph 15-18.

If APU does not run and **APU NO-GO OVERSPEED** appears on HOD, refer to TM 1-1520-238-T-3, APU Multiplex Read Codes, and perform troubleshooting. Then if no fault is found, go to paragraph 15-19.

15-12. AUXILIARY POWER UNIT - MAINTENANCE OPERATIONAL CHECK (cont)

15-12

Task	Result
	<p>If APU does not run and <b>APU NO-GO OVERSPEED</b> appears on HOD, refer to TM 1-1520-238-T-3, APU Multiplex Read Codes, and perform troubleshooting. Then, if no fault is found go to paragraph 15-20.</p> <p>If APU runs and <b>APU GO</b> appears, on HOD, but PTO clutch does not engage, go to paragraph 15-21.</p> <p>If APU does not run and <b>APU NO-GO LOW OIL PRESSURE</b> appears on HOD, refer to TM 1-1520-238-T-3, APU Multiplex Read Codes, and perform troubleshooting. Then, if no fault is found go to paragraph 15-22.</p>
<p>u. Shut down APU (TM 1-1520-238-CL).</p> <p>v. Have assistant visually inspect APU and aft deck for evidence of fuel or oil leakage, or physical damage resulting from APU operation.</p>	<p>If physical damage is evident, replace damaged components (TM 1-1520-238-23).</p> <p>If fuel or oil leakage is present, replace leaking components (TM 1-1520-238-23).</p>

3. Perform APU - POWER DOWN (para 15-11).
4. Install APU enclosure (TM 1-1520-238-23).
5. Secure L325, T250L, T250R, T290L and T290R access doors (TM 1-1520-238-23).
6. Install ammunition storage magazine and secure B200 access door (TM 9-1090-208-23-1).

END OF TASK

15-13. AUXILIARY POWER UNIT - WIRING INTERCONNECT DIAGRAM

15-13

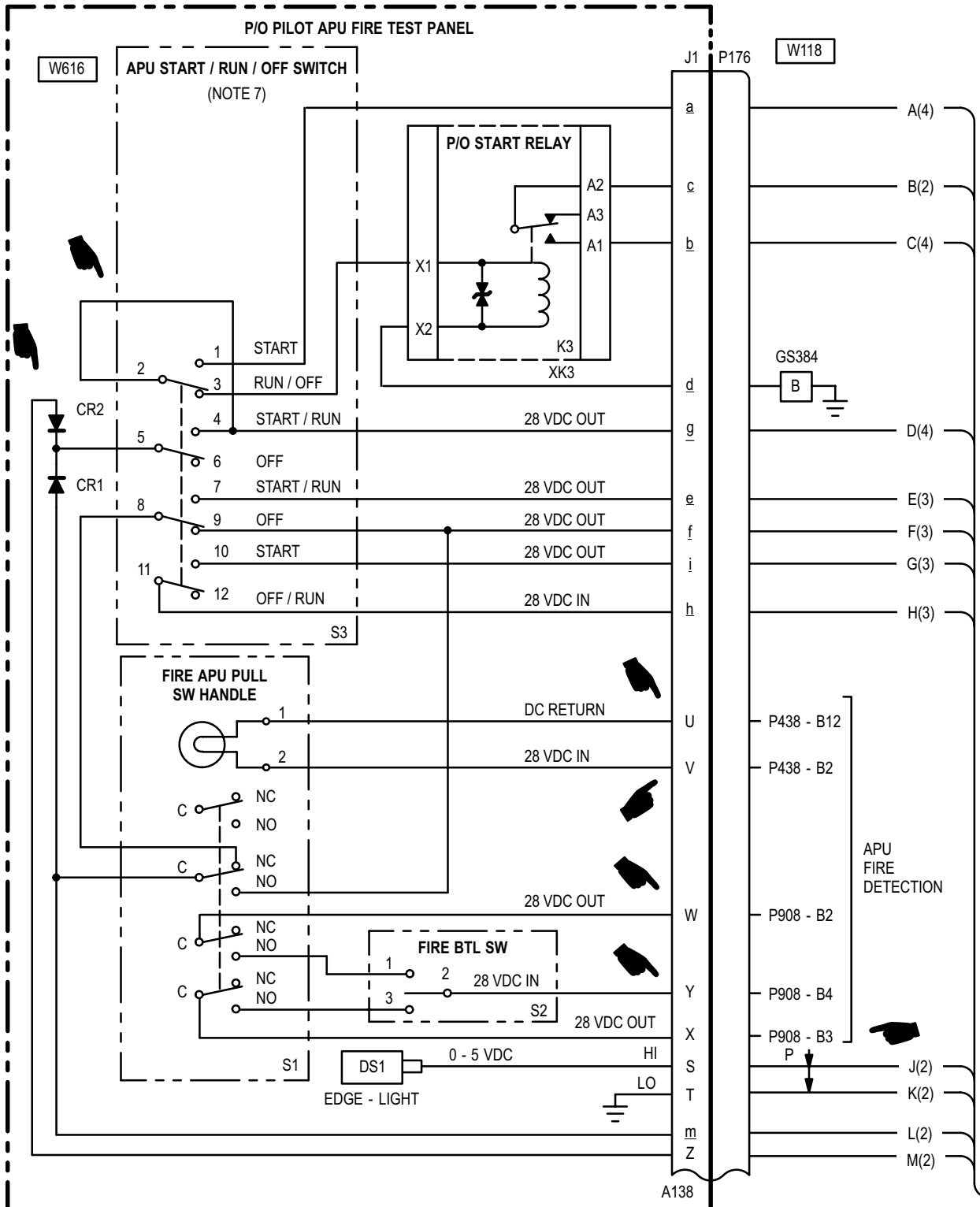

15-13. AUXILIARY POWER UNIT - WIRING INTERCONNECT DIAGRAM (cont)

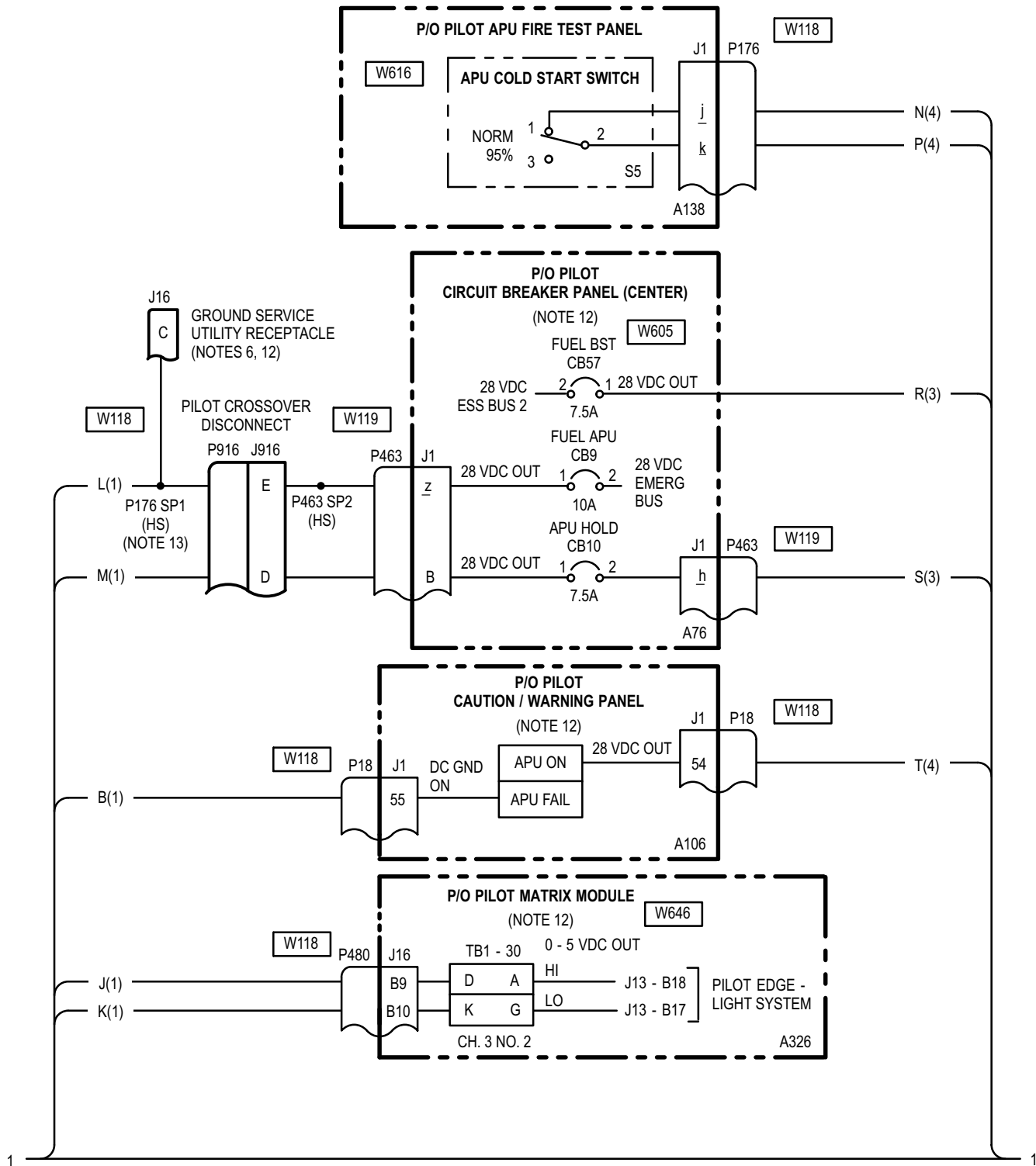

15-13. AUXILIARY POWER UNIT - WIRING INTERCONNECT DIAGRAM (cont)

15-13

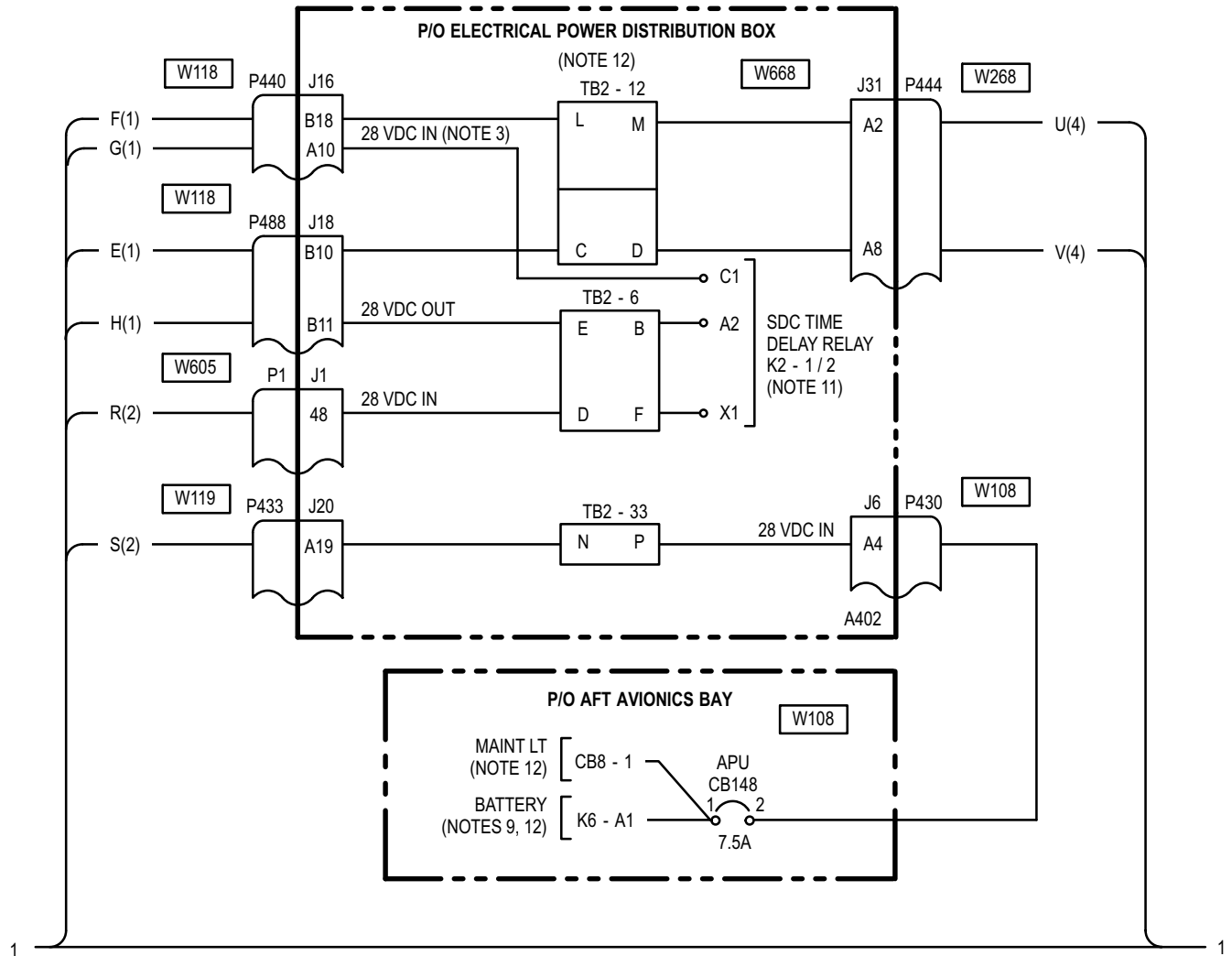

15-13. AUXILIARY POWER UNIT - WIRING INTERCONNECT DIAGRAM (cont)

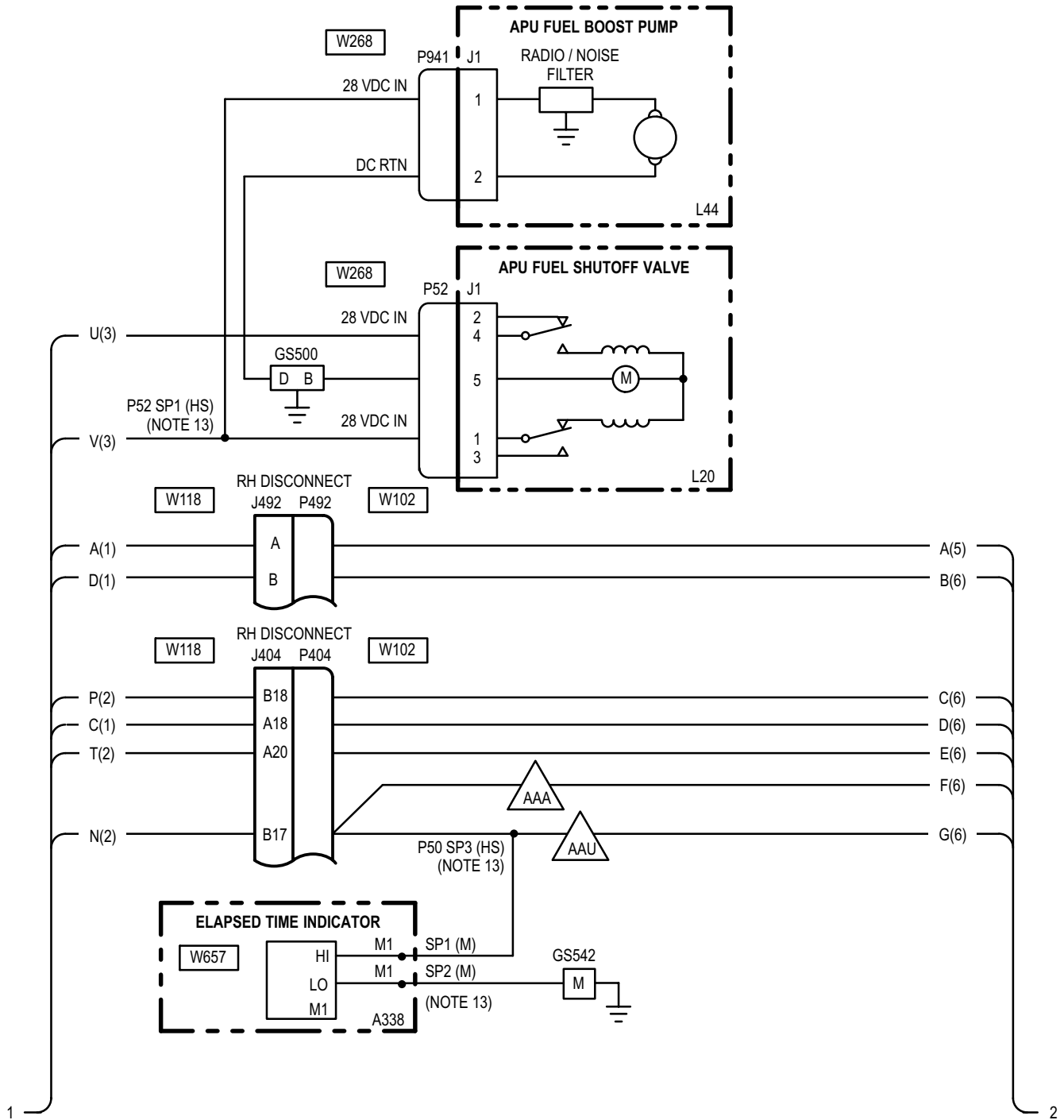

15-13. AUXILIARY POWER UNIT - WIRING INTERCONNECT DIAGRAM (cont)

15-13

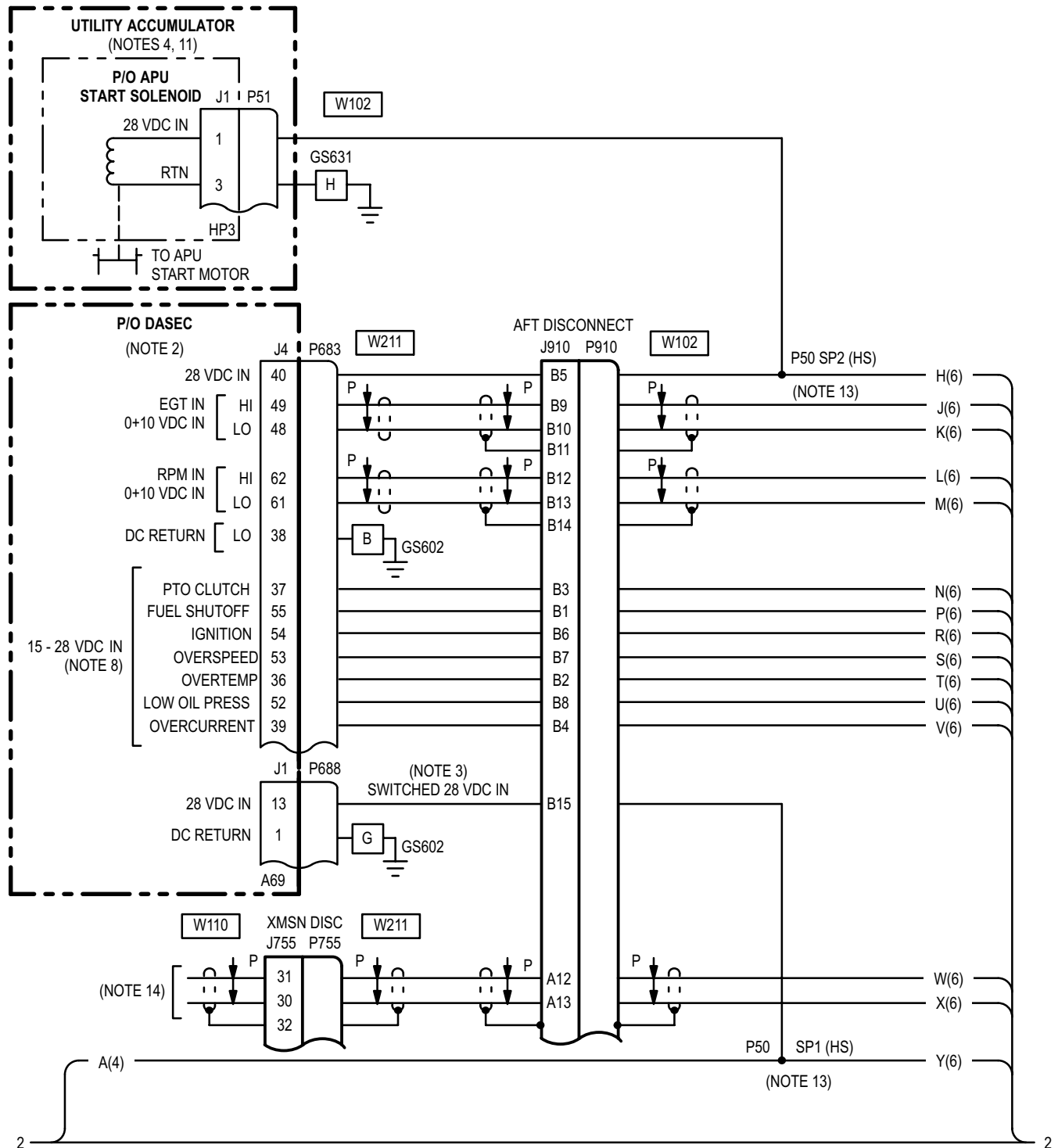

15-13. AUXILIARY POWER UNIT - WIRING INTERCONNECT DIAGRAM (cont)

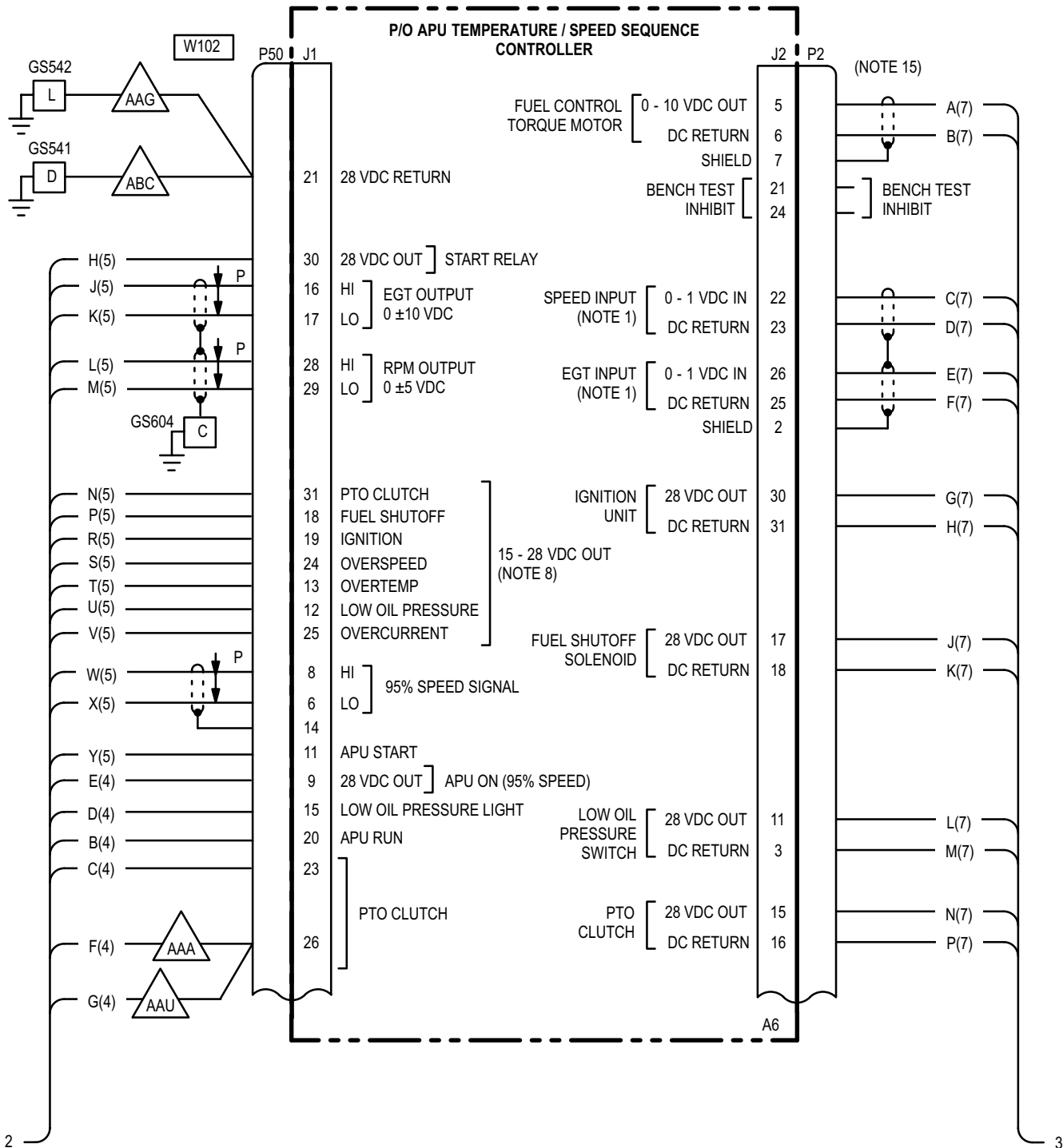



15-13. AUXILIARY POWER UNIT - WIRING INTERCONNECT DIAGRAM (cont)

15-13

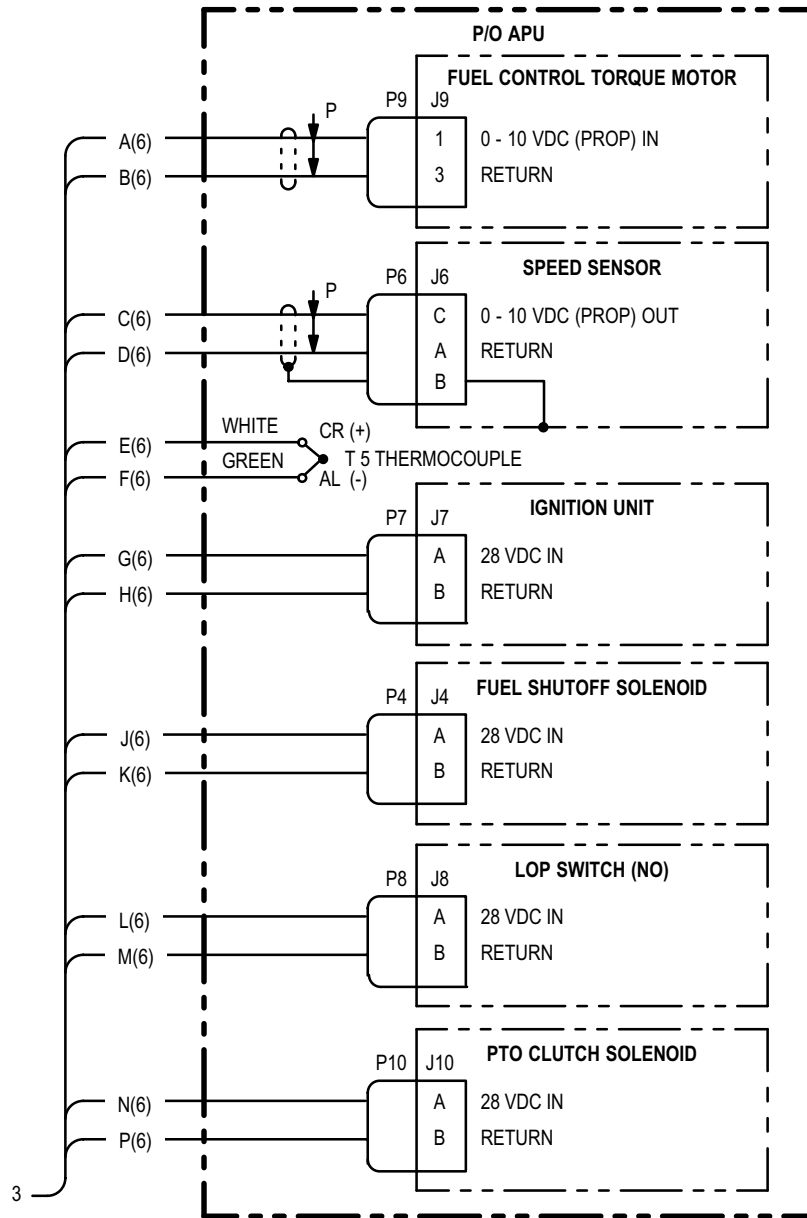

NOTES:

HIGHWAY USE: THE ALPHA CHARACTER IDENTIFIES A SPECIFIC LINE, AND THE NUMBER IN PARENTHESIS IDENTIFIES THE SHEET NUMBER WHERE THE SIGNAL TERMINATES.

1. 1 VDC = 10005 C AND/OR 120% N1.
2. AUTOMATIC STABILIZATION EQUIPMENT OF FLIGHT CONTROLS (TM 1-1520-238-T-7).
3. ONLY DURING APU START SEQUENCE.
4. 28 VDC OPENS VALVE ON UTILITY HYDRAULIC ACCUMULATOR.
5. SPRING LOADED TO NORM (CLOSED) POSITION.
6. PROVIDES EXTERNAL BATTERY DC POWER FOR STARTING APU.
7. APU START/RUN SWITCH KEY:

SWITCH POSITION	CIRCUITS CLOSED
OFF (AFT)	2-3; 5-6; 8-9; 11-12
RUN (CENTER)	2-3; 4-5; 7-8; 11-12
START (FWD)	1-2; 4-5; 7-8; 10-11

8. BELOW 10 VDC = FAULT; 15 TO 28 VDC = NO FAULT.
9. 28 VDC IN WHEN BATTERY IS CONNECTED.
10. LOSS OF THERMOCOUPLE INPUT = FAULT.
11. HYDRAULIC SYSTEM (TM 1-1520-238-T-5).
12. ELECTRICAL SYSTEM (TM 1-1520-238-T-6).
13. HS INDICATES A HARD SPLICE WHICH CANNOT BE DISCONNECTED. M INDICATES A SOFT SPLICE WHICH MAY BE DISCONNECTED FOR A WIRING CHECK.
14. DRIVE SYSTEM (TM 1-1520-238-T-4).
15. CONNECTOR SUPPLIED WITH APU.

**15-14. APU START SEQUENCE - DOES NOT BEGIN AND APU FAIL LIGHT ON PILOT CAUTION/WARNING PANEL ILLUMINATES**

15-14

**Tools:**

<u>Nomenclature</u>	<u>Part Number</u>
Tool Kit, Electrical Repairer's	SC518099CLA06
Multimeter, Digital	AN/PSM-45

**Personnel Required:**

68X Armament/Electrical Systems Repairer  
One person to assist

**References:**

TM 1-1520-238-23



**Turn off power before detaching or attaching wires and connectors. High current 28 VDC or 115 VAC is present. Failure to do so could result in death or serious injury.**

4. Set **START/RUN/OFF** to **START**, check for 28 VDC at P51-1.

**Is voltage present?**

- |     |   |
|-----|---|
| YES | Go to step 5.   |
| NO  | Replace APU temperature/speed sequence controller (TM 1-1520-238-23). |

5. Check for open between P51-3 and ground.

**Does open exist?**

- |     |   |
|-----|---|
| YES | Repair open wire. Go to paragraph 15-12.        |
| NO  | Replace APU start solenoid. (TM 1-1520-238-23). |

6. Check for open between P176-a and P50-11.

**Does open exist?**

- |     |  |
|-----|--|
| YES | Repair open wire. Go to paragraph 15-12.                     |
| NO  | Replace pilot <b>APU</b> fire test panel (TM 1-1520-238-23). |

1. Did **APU START SEQUENCE** momentarily engage, then disengage?

- |     |               |
|-----|---------------|
| YES | Go to step 2. |
| NO  | Go to step 3. |

2. Check for open between:

P2-26 and T5-CR(+),  
P2-25 and T5-AL(-).

**Does open exist?**

- |     |  |
|-----|--|
| YES | Repair open wire. Go to paragraph 15-12.             |
| NO  | Replace exhaust gas thermocouple (TM 1-1520-238-23). |

3. On pilot **APU** fire test panel, set **START/RUN/OFF** switch to **START** and check for 28 VDC at P50-11.

**Is voltage present?**

- |     |               |
|-----|---------------|
| YES | Go to step 4. |
| NO  | Go to step 6. |

END OF TASK

**15-15. APU - DOES NOT START (FD/LS DISPLAYS APU NO-GO )**

**15-15**

**Tools:**

<u>Nomenclature</u>	<u>Part Number</u>
Tool Kit, Electrical Repairer's	SC518099CLA06
Multimeter, Digital	AN/PSM-45

**Personnel Required:**

68X Armament/Electrical Systems Repairer

**References:**

TM 1-1520-238-23

**WARNING**

**Turn off power before detaching or attaching wires and connectors. High current 28 VDC or 115 VAC is present. Failure to do so could result in death or serious injury.**

1. Check for open between P2-22 and P2-23.

**Does open exist?**

- |     |               |
|-----|---------------|
| YES | Go to step 2. |
| NO  | Go to step 3. |

2. Check for open between: P2-22 and P6-C, P2-23 and P6-A.

**Does open exist?**

- |     |   |
|-----|---|
| YES | Repair open wire. Go to paragraph 15-12.              |
| NO  | Replace APU monopole speed sensor (TM 1-1520-238-23). |

3. Check for short between P2-22 and ground.

**Does short exist?**

- |     |               |
|-----|---------------|
| YES | Go to step 4. |
| NO  | Go to step 5. |

4. Detach P6. Check for short between J6-C and ground.

**Does short exist?**

- |     |   |
|-----|---|
| YES | Replace APU monopole speed sensor (TM 1-1520-238-23).                               |
| NO  | Repair shorted wire between: P2-22 and P6-C, P2-23 and P6-A. Go to paragraph 15-12. |

5. Check for short between P2-17 and ground.

**Does short exist?**

- |     |   |
|-----|---|
| YES | Go to step 6.   |
| NO  | Replace APU temperature/speed sequence controller (TM 1-1520-238-23). |

6. Check for short between J4-A and J4-B of APU fuel shutoff solenoid.

**Does short exist?**

- |     |   |
|-----|---|
| YES | Replace fuel shutoff solenoid (TM 1-1520-238-23).                                   |
| NO  | Repair shorted wire between: P2-17 and P4-A, P2-18 and P4-B. Go to paragraph 15-12. |

7. Check for open between: P2-17 and P4-A, P2-18 and P4-B.

**Does open exist?**

- |     |   |
|-----|---|
| YES | Repair open wire. Go to paragraph 15-12.          |
| NO  | Replace fuel shutoff solenoid (TM 1-1520-238-23). |

END OF TASK

15-16. APU - DOES NOT RUN (FD/LS DISPLAYS APU NO-GO OVERTEMP)

15-16

**Tools:**

<u>Nomenclature</u>	<u>Part Number</u>
Tool Kit, Electrical Repairer's	SC518099CLA06
Multimeter, Digital	AN/PSM-45

**Personnel Required:**

68X Armament/Electrical Systems Repairer  
One person to assist

**References:**

TM 1-1520-238-T-6  
TM 1-1520-238-23



**Turn off power before detaching or attaching wires and connectors. High current 28 VDC or 115 VAC is present. Failure to do so could result in death or serious injury.**

1. Check for open between P2-26 and P2-25.  
**Does open exist?**

YES	Go to step 10.
NO	Go to step 2.

2. With P2 attached and **START/RUN/OFF** switch on pilot **APU** fire test panel set to **RUN**, check for 15-28 VDC at P683-36.

**Is voltage present?**

YES	Replace APU (TM 1-1520-238-23).
NO	Go to step 3.

3. Check for open between P50-13 and P683-36.  
**Does open exist?**

YES	Repair open wire between: P50-13 and P910-B2, J910-B2 and P683-36. Go to paragraph 15-12.
NO	Go to step 4.

4. Check for 28 VDC at P50-20.  
**Is voltage present?**

YES	Replace APU temperature/speed sequence controller (TM 1-1520-238-23).
NO	Go to step 5.

5. Check for open between: P176-g and J492-B, P492-B and P50-20.

**Does open exist?**

YES	Repair open wire. Go to paragraph 15-12.
NO	Go to step 6.

6. Check for 28 VDC at P176-m.  
**Is voltage present?**

YES	Replace pilot <b>APU</b> fire test panel (TM 1-1520-238-23).
NO	Go to step 7.

7. On pilot center circuit breaker panel, close **APU FUEL BST** circuit breaker (CB57).  
**Is voltage present?**

YES	Go to step 8.
NO	Go to paragraph 15-32 to troubleshoot <b>FUEL APU</b> circuit breaker.

8. Check for 28 VDC at (A76)J1-z.  
**Is voltage present?**

YES	Repair open wire between: P463-z and J916-E, P916-E and P176-m. Go to paragraph 15-12.
NO	Go to step 9.

---

**15-16. APU - DOES NOT RUN (FD/LS DISPLAYS APU NO-GO OVERTEMP) (cont)**

---

**15-16**

9. Check for open between (A76)J1-z and CB9.

**Does open exist?**

- |     |  |
|-----|--|
| YES | Repair open wire between (A76)J1-z and CB9.<br>Go to paragraph 15-12.                                    |
| NO  | Refer to TM 1-1520-238-T-6 to troubleshoot circuit protection system (dc emergency bus - pilot station). |

10. Check for open between:

P2-26 and T5-CR(+),

P2-25 and T5-AL(-).

**Does open exist?**

- |     |  |
|-----|--|
| YES | Repair open wire.<br>Go to paragraph 15-12.          |
| NO  | Replace exhaust gas thermocouple (TM 1-1520-238-23). |

END OF TASK

15-17. APU - DOES NOT RUN (FD/LS DISPLAYS APU NO-GO UNDERSPEED)

15-17

**Tools:**

<u>Nomenclature</u>	<u>Part Number</u>
Tool Kit, Electrical Repairer's	SC518099CLA06
Multimeter, Digital	AN/PSM-45

**Personnel Required:**

68X Armament/Electrical Systems Repairer  
One person to assist

**References:**

TM 1-1520-238-T-1  
TM 55-1520-238-23

**Equipment Conditions:**

<u>Ref</u>	<u>Condition</u>
TM 55-1520-238-23	APU enclosure removed Access provisions - R295 door open



**Turn off power before detaching or attaching wires and connectors. High current 28 VDC or 115 VAC is present. Failure to do so could result in death or serious injury.**

- On pilot **APU** fire test panel, set **START/RUN/OFF** switch to **RUN** and check for 15-28 VDC at P50-20.  
**Is voltage present?**  

YES	Go to step 3.
NO	Go to step 2.
- Check for open between:  
P176-g and J492-B,  
P492-B and P50-20.  

YES	Repair open wire. Go to paragraph 15-12.
NO	Replace pilot <b>APU</b> fire test panel (TM 55-1520-238-23).

- Detach P9, P7, P4 and P10. Set **START/RUN/OFF** switch to **RUN** and check for 15-28 VDC at P683-39.  
**Is voltage present?**  

YES	Go to step 4.
NO	Go to step 7.
- Attach P9. Set **START/RUN/OFF** switch to **RUN** and check for 15-28 VDC at P683-39.  
**Is voltage present?**  

YES	Go to step 5.
NO	Replace fuel control torque motor (TM 55-1520-238-23).
- Attach P7. Set **START/RUN/OFF** switch to **RUN** and check for 15-28 VDC at P683-39.  
**Is voltage present?**  

YES	Go to step 6.
NO	Replace ignition unit (TM 55-1520-238-23).
- Attach P4. Set **START/RUN/OFF** switch to **RUN** and check for 15-28 VDC at P683-39.  
**Is voltage present?**  

YES	Go to step 9.
NO	Replace fuel shutoff solenoid (TM 55-1520-238-23).
- Check for open between P50-25 and P683-39.  
**Does open exist?**  

YES	Repair open wire. Go to paragraph 15-12.
NO	Go to step 8.

**15-17. APU - DOES NOT RUN (FD/LS DISPLAYS APU NO-GO UNDERSPEED)****15-17**

8. Check for open between:  
P2-5 and P9-1,  
P2-6 and P9-3,  
P2-30 and P7-A,  
P2-31 and P7-B,  
P2-17 and P4-A,  
P2-18 and P4-B,  
P2-16 and P10-B,  
P2-15 and P10-A.  
**Does short exist?**
- |     |  |
|-----|--|
| YES | Repair open wire.<br>Go to paragraph 15-12.                                  |
| NO  | Replace APU<br>temperature/speed sequence<br>controller (TM 55-1520-238-23). |
9. Set **START/RUN/OFF** switch to **RUN** and check for 15-28 VDC at P683-55.  
**Is voltage present?**
- |     |                |
|-----|----------------|
| YES | Go to step 10. |
| NO  | Go to step 11. |
10. Check for open between:  
P4-A and P2-17,  
P4-B and P2-18.  
**Does open exist?**
- |     |  |
|-----|--|
| YES | Repair open wire.<br>Go to paragraph 15-12.                                  |
| NO  | Replace APU<br>temperature/speed sequence<br>controller (TM 55-1520-238-23). |
11. Set **START/RUN/OFF** switch to **RUN** and check for 28 VDC between P7-A and P7-B.  
**Is voltage present?**
- |     |                |
|-----|----------------|
| YES | Go to step 13. |
| NO  | Go to step 12. |
12. Check for open between:  
P2-30 and P7-A,  
P2-31 and P7-B.  
**Does open exist?**
- |     |  |
|-----|--|
| YES | Repair open wire.<br>Go to paragraph 15-12.                                  |
| NO  | Replace APU<br>temperature/speed sequence<br>controller (TM 55-1520-238-23). |
13. Replace PTO clutch solenoid (TM 55-1520-238-23). Perform FD/LS check (TM 1-1520-238-T-1).  
**Does FD/LS display APU NO-GO UNDERSPEED?**
- |     |                        |
|-----|------------------------|
| YES | Go to step 14.         |
| NO  | Go to paragraph 15-12. |
14. Replace APU ignition unit (TM 55-1520-238-23). Perform FD/LS check (TM 1-1520-238-T-1).  
**Does FD/LS display APU NO-GO UNDERSPEED?**
- |     |                        |
|-----|------------------------|
| YES | Go to step 15.         |
| NO  | Go to paragraph 15-12. |
15. Replace APU fuel shutoff solenoid (TM 55-1520-238-23). Perform FD/LS check (TM 1-1520-238-T-1).  
**Does FD/LS display APU NO-GO UNDERSPEED?**
- |     |  |
|-----|--|
| YES | Replace APU<br>temperature/speed sequence<br>controller (TM 55-1520-238-23). |
| NO  | Go to paragraph 15-12.   |

END OF TASK

---

**15-18. APU - RUNS (FD/LS DISPLAYS APU NO-GO UNDERSPEED AND CLUTCH DOES NOT ENGAGE)**

---

15-18

**Tools:**

<u>Nomenclature</u>	<u>Part Number</u>
Tool Kit, Electrical Repairer's	SC518099CLA06
Multimeter, Digital	AN/PSM-45

**Personnel Required:**

68X Armament/Electrical Systems Repairer  
One person to assist

**References:**

TM 55-1520-238-23

---

<b>WARNING</b>
----------------

**Turn off power before detaching or attaching wires and connectors. High current 28 VDC or 115 VAC is present. Failure to do so could result in death or serious injury.**

- On pilot **APU** fire test panel, set **START/RUN/OFF** switch to **RUN** and check for 0 to 10 VDC between P9-1 and P9-3.  
**Is voltage present?**

YES	Replace fuel control torque motor (TM 55-1520-238-23).
NO	Go to step 2.
- Check for open between:  
P2-5 and P9-1,  
P2-6 and P9-3.  
**Does open exist?**

YES	Repair open wire. Go to paragraph 15-12.
NO	Replace APU temperature/speed sequence controller (TM 55-1520-238-23).

END OF TASK



**15-19. APU - DOES NOT RUN (FD/LS DISPLAYS APU NO-GO OVERSPEED)**

**15-19**

**Tools:**

<u>Nomenclature</u>	<u>Part Number</u>
Multimeter, Digital	AN/PSM-45

**Personnel Required:**

68X Armament/Electrical Systems Repairer  
One person to assist

**References:**

TM 1-1520-238-T-1  
TM 55-1520-238-23

- Replace APU monopole speed sensor (TM 55-1520-238-23). Perform FD/LS check (TM 1-1520-238-T-1).

**Does FD/LS display APU GO?**

YES	Go to paragraph 15-12.
NO	Replace APU temperature/speed sequence controller (TM 55-1520-238-23).

**WARNING**

**Turn off power before detaching or attaching wires and connectors. High current 28 VDC or 115 VAC is present. Failure to do so could result in death or serious injury.**

- On pilot **APU** fire test panel, set **START/RUN/OFF** switch to **RUN** and check for 15-28 VDC at P683-53.

**Is voltage present?**

YES	Replace APU (TM 55-1520-238-23).
NO	Go to step 2.

- Check for open between P683-53 and P50-24.

**Does open exist?**

YES	Repair open wire. Go to paragraph 15-12.
NO	Go to step 3.

- Check for open between: P2-22 and P6-C, P2-23 and P6-A.

**Does open exist?**

YES	Repair open wire. Go to paragraph 15-12.
NO	Go to step 4.

END OF TASK

**15-20. APU - RUNS (FD/LS DISPLAYS APU NO-GO OVERSPEED)****15-20****Tools:**

<u>Nomenclature</u>	<u>Part Number</u>
Tool Kit, Electrical Repairer's	SC518099CLA06
Multimeter, Digital	AN/PSM-45

**Personnel Required:**

68X Armament/Electrical Systems Repairer  
One person to assist

**References:**

TM 55-1520-238-23

<b>WARNING</b>
----------------

**Turn off power before detaching or attaching wires and connectors. High current 28 VDC or 115 VAC is present. Failure to do so could result in death or serious injury.**

- On pilot **APU** fire test panel, set **START/RUN/OFF** switch to **RUN** and check for 15-28 VDC at P683-53.  
**Is voltage present?**

YES	Replace DASEC (TM 55-1520-238-23).
NO	Go to step 2.
- Check for open between P50-24 and P683-53.  
**Does open exist?**

YES	Repair open wire. Go to paragraph 15-12.
NO	Replace APU temperature/speed sequence controller (TM 55-1520-238-23).

END OF TASK

**15-21. APU - RUNS (FD/LS DISPLAYS APU GO) BUT PTO CLUTCH DOES NOT ENGAGE**

**15-21**

**Tools:**

<u>Nomenclature</u>	<u>Part Number</u>
Tool Kit, Electrical Repairer's	SC518099CLA06
Multimeter, Digital	AN/PSM-45

**Personnel Required:**

68X Armament/Electrical Systems Repairer  
One person to assist

**References:**

TM 1-1520-238-23

**Equipment Conditions:**

<u>Ref</u>	<u>Condition</u>
TM 1-1520-238-23	APU enclosure removed Access provisions - R295 door removed

2. Detach P10.

Check for open between:  
P2-15 and P10-A,  
P2-16 and P10-B.

**Does open exist?**

YES	Repair open wire. Go to paragraph 15-12.
NO	Replace PTO-clutch solenoid (TM 1-1520-238-23).



**Turn off power before detaching or attaching wires and connectors. High current 28 VDC or 115 VAC is present. Failure to do so could result in death or serious injury.**

1. Detach P2 from **APU** temperature/speed sequence control unit. On pilot **APU** fire test panel, set **START/RUN/OFF** switch to **START**, check for 28 VDC at J2-15.

**Is voltage present?**

YES	Go to Step 2.
NO	Replace APU temperature/speed sequence controller (TM 1-1520-238-23).

END OF TASK

**15-22. APU - DOES NOT RUN (FD/LS DISPLAYS APU NO-GO LOW OIL PRESSURE)**

**15-22**

**Tools:**

<u>Nomenclature</u>	<u>Part Number</u>
Tool Kit, Electrical Repairer's	SC518099CLA06
Multimeter, Digital	AN/PSM-45

**Personnel Required:**

68X Armament/Electrical Systems Repairer  
One person to assist

**References:**

TM 1-1520-238-23

**Equipment Conditions:**

<u>Ref</u>	<u>Condition</u>
TM 1-1520-238-23	APU enclosure removed Access provisions - R295 door removed



**Turn off power before detaching or attaching wires and connectors. High current 28 VDC or 115 VAC is present. Failure to do so could result in death or serious injury.**

1. On pilot **APU** fire test panel, set **START/RUN/OFF** switch to **RUN** and check for 28 VDC between P8-A and P8-B.

**Is voltage present?**

- |     |   |
|-----|---|
| YES | Replace APU oil pressure switch (TM 1-1520-238-23). |
| NO  | Go to step 2.                                       |

2. Detach P2. Check for short between P8-A and P8-B.

**Does short exist?**

- |     |   |
|-----|---|
| YES | Repair shorted wire between: P8-A and P2-11, P8-B and P2-3.<br>Go to paragraph 15-12. |
| NO  | Replace APU temperature/speed sequence controller (TM 1-1520-238-23).                 |

END OF TASK

**15-23. APU FUEL SHUTOFF VALVE - DOES NOT OPEN WITH START/RUN/OFF SWITCH SET TO RUN**

15-23

**Tools:**

<u>Nomenclature</u>	<u>Part Number</u>
Tool Kit, Electrical Repairer's	SC518099CLA06
Multimeter, Digital	AN/PSM-45

**Personnel Required:**

68X Armament/Electrical Systems Repairer  
One person to assist

**References:**

TM 1-1520-238-T-6  
TM 1-1520-238-23

**Equipment Conditions:**

<u>Ref</u>	<u>Condition</u>
TM 1-1520-238-23	Access provisions - R200 panel removed

**WARNING**

**Turn off power before detaching or attaching wires and connectors. High current 28 VDC or 115 VAC is present. Failure to do so could result in death or serious injury.**

1. On pilot **APU** fire test panel, set **START/RUN/OFF** switch to **RUN**. Check for 28 VDC at P488-B10.  
**Is voltage present?**

YES	Go to step 7.
NO	Go to step 2.
  
2. Check for open between P176-e and P488-B10.  
**Does open exist?**

YES	Repair open wire. Go to paragraph 15-12.
NO	Go to step 3.

3. Check for 28 VDC at P176-m.  
**Is voltage present?**

YES	Replace pilot <b>APU</b> fire test panel (TM 55-1520-238-23).
NO	Go to step 4.
  
4. On pilot center circuit breaker panel, close **FUEL BST** circuit breaker (CB57).  
**Does circuit breaker stay closed?**

YES	Go to step 5.
NO	Go to paragraph 15-31 to troubleshoot <b>FUEL BST</b> circuit breaker.
  
5. Check for 28 VDC at (A76)J1-z.  
**Is voltage present?**

YES	Repair open wire between: P463-z and J916-E, P916-E and P176-m. Go to paragraph 15-12.
NO	Go to step 6.
  
6. Check for open between (A76)J1-z and CB9.  
**Does open exist?**

YES	Repair open wire between (A76)J1-z and CB9. Go to paragraph 15-12.
NO	Refer to TM 1-1520-238-T-6 to troubleshoot circuit protection system (dc emergency bus - pilot station).
  
7. Check for open between J18-B10 and P52-1.  
**Does open exist?**

YES	Repair open wire between: P444-A8 and P52-1. (A402): J18-B10 and TB2-12-C, TB2-12-D and J31-A8. Go to paragraph 15-12.
NO	Go to step 8.

---

**15-23. APU FUEL SHUTOFF VALVE - DOES NOT OPEN WITH START/RUN/OFF SWITCH  
SET TO RUN (cont)**

---

**15-23**

8. Check for open between P52-5 and ground.

**Does open exist?**

- |     |  |
|-----|--|
| YES | Repair open wire.<br>Go to paragraph 15-12.            |
| NO  | Replace APU fuel shutoff valve<br>(TM 55-1520-238-23). |

END OF TASK

---

**15-24. APU FUEL BOOST PUMP - DOES NOT OPERATE WITH START/RUN/OFF SWITCH SET TO RUN**

---

15-24

**Tools:**

<u>Nomenclature</u>	<u>Part Number</u>
Tool Kit, Electrical Repairer's	SC518099CLA06
Multimeter, Digital	AN/PSM-45

**Personnel Required:**

68X Armament/Electrical Systems Repairer

**References:**

TM 55-1520-238-23  
 TM 9-1090-208-23-1

**Equipment Conditions:**

<u>Ref</u>	<u>Condition</u>
TM 55-1520-238-23	Access provisions - B200 door removed
TM 9-1090-208-23-1	Ammo storage magazine removed

---

<b>WARNING</b>
----------------

**Turn off power before detaching or attaching wires and connectors. High current 28 VDC or 115 VAC is present. Failure to do so could result in death or serious injury.**

Check for open between:  
 P52-1 and P941-1,  
 P941-2 and ground.

**Does open exist?**

YES	Repair open wire. Go to paragraph 15-12.
NO	Replace APU fuel boost pump (TM 55-1520-238-23).

END OF TASK

**15-25. APU FUEL SHUTOFF VALVE - DOES NOT CLOSE WITH APU FIRE PULL HANDLE PULLED** **15-25**

**Tools:**

<u>Nomenclature</u>	<u>Part Number</u>
Tool Kit, Electrical Repairer's	SC518099CLA06
Multimeter, Digital	AN/PSM-45

**Personnel Required:**

68X Armament/Electrical Systems Repairer  
One person to assist

**References:**

TM 1-1520-238-T-6  
TM 55-1520-238-23



**Turn off power before detaching or attaching wires and connectors. High current 28 VDC or 115 VAC is present. Failure to do so could result in death or serious injury.**

1. On pilot **APU** fire test panel, pull **APU FIRE PULL** handle, check for 28 VDC at P440-B18.  
**Is voltage present?**
  - YES Go to step 7.
  - NO Go to step 2.
2. Check for 28 VDC at P176-m.  
**Is voltage present?**
  - YES Go to step 3.
  - NO Go to step 4.
3. Check for open between P176-f and P440-B18.  
**Does open exist?**
  - YES Repair open wire.  
Go to paragraph 15-12.
  - NO Replace pilot **APU** fire test panel (TM 55-1520-238-23).
4. On pilot center circuit breaker panel, close **FUEL BST** circuit breaker (CB57).  
**Does circuit breaker stay closed?**
  - YES Go to step 5.
  - NO Go to paragraph 15-31 to troubleshoot **FUEL BST** circuit breaker.
5. Check for 28 VDC at (A76)J1-z.  
**Is voltage present?**
  - YES Repair open wire between: P463-Z and J916-E, P916-E and P176-m.  
Go to paragraph 15-12.
  - NO Go to step 6.
6. Check for open between (A76)J1-z and CB9.  
**Does open exist?**
  - YES Repair open wire between (A76)J1-z and CB9.  
Go to paragraph 15-12.
  - NO Refer to TM 1-1520-238-T-6 to troubleshoot circuit protection system (dc emergency bus - pilot station).
7. Attach P440. Check for 28 VDC at P52-4.  
**Is voltage present?**
  - YES Go to step 8.
  - NO Repair open wire between: P444-A2 and P52-4. (A402): J16-B18 and TB2-12-L, TB2-12-M and J31-A2.  
Go to paragraph 15-12.
8. Check for open between P52-5 and ground.  
**Does open exist?**
  - YES Repair open wire.  
Go to paragraph 15-12.
  - NO Replace APU fuel shutoff valve (TM 55-1520-238-23).

END OF TASK



**15-26. APU FUEL SHUTOFF VALVE - DOES NOT CLOSE WITH START/RUN/OFF SWITCH SET TO OFF**

15-26

**Tools:**

<u>Nomenclature</u>	<u>Part Number</u>
Tool Kit, Electrical Repairer's	SC518099CLA06
Multimeter, Digital	AN/PSM-45

**Personnel Required:**

68X Armament/Electrical Systems Repairer  
One person to assist

**References:**

TM 1-1520-238-T-6  
TM 55-1520-238-23  
TM 9-1090-208-23-1

**Equipment Conditions:**

<u>Ref</u>	<u>Condition</u>
TM 55-1520-238-23	Access provisions - B200 door removed
TM 9-1090-208-23-1	Ammo storage magazine removed

**WARNING**

**Turn off power before detaching or attaching wires and connectors. High current 28 VDC or 115 VAC is present. Failure to do so could result in death or serious injury.**

1. Check for 28 VDC at P52-4.  
**Is voltage present?**
  - YES Go to step 7.
  - NO Go to step 2.

2. Check for open between P176-f and P52-4.  
**Does open exist?**
  - YES Repair open wire between: P176-f and P440-B18, P444-A2 and P52-4. (A402): TB2-12-M and J31-A2, J16-B18 and TB2-12-L. Go to paragraph 15-12.
  - NO Go to step 3.
3. Check for 28 VDC at P176-m.  
**Is voltage present?**
  - YES Replace pilot **APU** fire test panel (TM 55-1520-238-23).
  - NO Go to step 4.
4. On pilot center circuit breaker panel, close **FUEL BST** circuit breaker (CB57).  
**Does circuit breaker stay closed?**
  - YES Go to step 5.
  - NO Go to paragraph 15-31 to troubleshoot **FUEL BST** circuit breaker.
5. Check for 28 VDC at (A76)J1-z.  
**Is voltage present?**
  - YES Repair open wire between: P463-Z and J916-E, P916-E and P176-m. Go to paragraph 15-12.
  - NO Go to step 6.
6. Check for open between (A76)J1-z and CB9-2.  
**Does open exist?**
  - YES Repair open wire between (A76)J1-z and CB9-2. Go to paragraph 15-12.
  - NO Refer to TM 1-1520-238-T-6 to troubleshoot circuit protection system (dc emergency bus - pilot station).

---

**15-26. APU FUEL SHUTOFF VALVE - DOES NOT CLOSE WITH START/RUN/OFF SWITCH  
SET TO OFF (cont)**

---

**15-26**

7. Check for open between P52-5 and ground.

**Does open exist?**

- |     |  |
|-----|--|
| YES | Repair open wire.<br>Go to paragraph 15-12.            |
| NO  | Replace APU fuel shutoff valve<br>(TM 55-1520-238-23). |

END OF TASK

**15-27. APU ON INDICATOR - IS NOT LIGHTED 60 SECONDS AFTER APU START****15-27****Tools:**

<u>Nomenclature</u>	<u>Part Number</u>
Tool Kit, Electrical Repairer's	SC518099CLA06
Multimeter, Digital	AN/PSM-45

**Personnel Required:**

68X Armament/Electrical Systems Repairer  
One person to assist

**References:**

TM 1-1520-238-T-6  
TM 55-1520-238-23

<b>WARNING</b>
----------------

**Turn off power before detaching or attaching wires and connectors. High current 28 VDC or 115 VAC is present. Failure to do so could result in death or serious injury.**

1. Check for 28 VDC at P18-54.

**Is voltage present?**

YES	Refer to TM 1-1520-238-T-6 to troubleshoot pilot caution/warning system.
NO	Go to step 2.

2. Shut down APU. Check for open between P50-9 and P18-54.

**Does open exist?**

YES	Replace APU temperature/speed sequence controller (TM 55-1520-238-23).
NO	Repair open wire between: P18-54 and J404-A20, P404-A20 and P50-9. Go to paragraph 15-12.

END OF TASK

**15-28. PRI HYD PSI, UTIL HYD PSI, AND SHAFT DRIVEN COMP INDICATORS - ARE NOT LIGHTED WITH 95%/NORM SWITCH SET AT 95% AND APU OPERATING** **15-28**

**Tools:**

<u>Nomenclature</u>	<u>Part Number</u>
Tool Kit, Electrical Repairer's	SC518099CLA06
Multimeter, Digital	AN/PSM-45

**Personnel Required:**

68X Armament/Electrical Systems Repairer  
One person to assist

**References:**

TM 1-1520-238-T-6  
TM 1-1520-238-23

**WARNING**

**Turn off power before detaching or attaching wires and connectors. High current 28 VDC or 115 VAC is present. Failure to do so could result in death or serious injury.**

1. Have assistant check APU drive shaft.

**Is shaft rotating?**

- |     |  |
|-----|--|
| YES | Refer to TM 1-1520-238-T-6 to troubleshoot pilot caution/warning system. |
| NO  | Go to step 2.  |

2. Shut down APU with **95%/NORM** switch on pilot **APU** fire test panel set to **95%**. Check for open between P50-23 and P50-26.

**Does open exist?**

- |     |               |
|-----|---------------|
| YES | Go to step 3. |
| NO  | Go to step 5. |

3. Check APU drive shaft to see if PTO clutch is engaged with APU at rest.

**Is PTO clutch engaged?**

- |     |   |
|-----|---|
| YES | Replace PTO clutch (TM 55-1520-238-23). |
| NO  | Go to step 4.                           |

4. Check for open between:

P2-16 and P10-A,  
P2-15 and P10-B.

**Does short exist?**

- |     |  |
|-----|--|
| YES | Repair open wire.<br>Go to paragraph 15-12.                            |
| NO  | Replace APU temperature/speed sequence controller (TM 55-1520-238-23). |

5. Check for open between (A138): J1-j and J1-k with **95%/NORM** switch set to **95%**.

**Does open exist?**

- |     |   |
|-----|---|
| YES | Repair open wire between: P176-j and J404-B17, P176-k and J404-B18, P404-B17 and P50-26, P404-B18 and P50-23.<br>Go to paragraph 15-12. |
| NO  | Replace pilot <b>APU</b> fire test panel (TM 55-1520-238-23).   |

END OF TASK

**15-29. PRI HYD PSI, UTIL HYD PSI AND SHAFT DRIVEN COMP INDICATORS - ARE LIGHTED WITH 95%/NORM SWITCH SET AT NORM AND APU OPERATING 15-29**

**Tools:**

<u>Nomenclature</u>	<u>Part Number</u>
Tool Kit, Electrical Repairer's	SC518099CLA06
Multimeter, Digital	AN/PSM-45

**Personnel Required:**

68X Armament/Electrical Systems Repairer  
One person to assist

**References:**

TM 1-1520-238-T-6  
TM 55-1520-238-23

<b>WARNING</b>
----------------

**Turn off power before detaching or attaching wires and connectors. High current 28 VDC or 115 VAC is present. Failure to do so could result in death or serious injury.**

1. Have assistant check APU drive shaft.

**Is shaft rotating?**

- |     |  |
|-----|--|
| YES | Refer to TM 1-1520-238-T-6 to troubleshoot pilot caution/warning system. |
| NO  | Go to step 2.  |

2. Shut down APU. Check for open between P50-23 and P50-26.

**Does open exist?**

- |     |               |
|-----|---------------|
| YES | Go to step 3. |
| NO  | Go to step 4. |

3. Check for open between:

P176-j and J404-B17,  
P176-k and J404-B18,  
P404-B17 and P50-26,  
P404-B18 and P50-23.

**Does open exist?**

- |     |   |
|-----|---|
| YES | Repair open wire.<br>Go to paragraph 15-12.                   |
| NO  | Replace pilot <b>APU</b> fire test panel (TM 55-1520-238-23). |

4. Check PTO clutch engagement by grounding P2-16 and applying 28 VDC to P2-15.

**Does PTO clutch engage APU drive shaft?**

- |     |  |
|-----|--|
| YES | Replace APU temperature/speed sequence controller (TM 55-1520-238-23). |
| NO  | Replace PTO clutch (TM 55-1520-238-23).                                |

END OF TASK

**15-30. APU/FIRE TEST PANEL EDGE-LIGHT - IS NOT LIGHTED**

**15-30**

**Tools:**

<u>Nomenclature</u>	<u>Part Number</u>
Tool Kit, Electrical Repairer's	SC518099CLA06
Multimeter, Digital	AN/PSM-45

**Personnel Required:**

68X Armament/Electrical Systems Repairer  
One person to assist

**References:**

TM 1-1520-238-T-6  
TM 55-1520-238-23

**Equipment Conditions:**

<u>Ref</u>	<u>Condition</u>
TM 55-1520-238-23	Non-transparent barrier removed



**Turn off power before detaching or attaching wires and connectors. High current 28 VDC or 115 VAC is present. Failure to do so could result in death or serious injury.**

1. Check for 5 VDC between (A326): TB1-30-D and TB1-30-K.

**Is voltage present?**

- |     |   |
|-----|---|
| YES | Go to step 2.   |
| NO  | Refer to TM 1-1520-238-T-6 to troubleshoot pilot and CPG edge-lights. |

2. Check for open between: (A326)TB1-30-D and P176-S, (A326)TB1-30-K and P176-T.

**Does open exist?**

- |     |   |
|-----|---|
| YES | Repair open wire. Go to paragraph 15-12.  |
| NO  | Replace pilot <b>APU</b> fire test light transmitting indicating panel (TM 55-1520-238-23). |

END OF TASK

**15-31. FUEL BST CIRCUIT BREAKER (CB57) - DOES NOT STAY CLOSED**

**15-31**

**Tools:**

<u>Nomenclature</u>	<u>Part Number</u>
Tool Kit, Electrical Repairer's	SC518099CLA06
Multimeter, Digital	AN/PSM-45

**Personnel Required:**

68X Armament/Electrical Systems Repairer  
One person to assist

**References:**

TM 1-1520-238-T-5  
TM 1-1520-238-T-6  
TM 55-1520-238-23



**Turn off power before detaching or attaching wires and connectors. High current 28 VDC or 115 VAC is present. Failure to do so could result in death or serious injury.**

1. Detach P1. On pilot center circuit breaker panel, close **FUEL BST** circuit breaker (CB57).

**Does circuit breaker stay closed?**

YES	Go to step 2.
NO	Go to step 5.

2. Check for short between:

P176-i and ground,  
P440-A10 and ground,  
P176-h and ground,  
P488-B11 and ground.

**Does short exist?**

YES	Repair shorted wire between: P176-i and P440-A10, P176-h and P440-B11. Go to paragraph 15-12.
NO	Go to step 3.

3. On pilot **APU** fire test panel, hold **START/RUN/OFF** switch in **START** position, check for short between (A138):  
J1-h and J1-i.

**Does short exist?**

YES	Replace pilot <b>APU</b> fire test panel (TM 55-1520-238-23).
NO	Go to step 4.

4. Check for short between (A402):

J1-48 and ground,  
TB2-6-D and ground,  
J18-B11 and ground,  
TB2-6-E and ground,  
J16-A10 and ground,  
K2-1/2-C1 and ground,  
TB2-6-F and ground,  
K2-1/2-X1 and ground,  
TB2-6-B and ground,  
K2-1/2-A2 and ground.

**Does short exist?**

YES	Repair shorted wire between (A402): J1-48 and TB2-6-D, J18-B11 and TB2-6-E, J16-A10 and K2-1/2-C1, TB2-6-F and K2-1/2-X1, TB2-6-B and K2-1/2-A2. Go to paragraph 15-12.
NO	Refer to TM 1-1520-238-T-5 to troubleshoot PAS.

5. Check for short between:

P1-48 and ground,  
CB57-2 and ground.

**Does short exist?**

YES	Repair shorted wire between P1-48 and CB57-2. Go to paragraph 15-12.
NO	Refer to TM 1-1520-238-T-6 to troubleshoot circuit protection system (dc essential bus 2 - pilot station).

END OF TASK

**15-32. FUEL APU CIRCUIT BREAKER (CB9) - DOES NOT STAY CLOSED**

**15-32**

**Tools:**

<u>Nomenclature</u>	<u>Part Number</u>
Tool Kit, Electrical Repairer's	SC518099CLA06
Multimeter, Digital	AN/PSM-45

**Personnel Required:**

68X Armament/Electrical Systems Repairer

**References:**

TM 1-1520-238-T-6  
 TM 55-1520-238-23



**Turn off power before detaching or attaching wires and connectors. High current 28 VDC or 115 VAC is present. Failure to do so could result in death or serious injury.**

- On pilot center circuit breaker panel, open **FUEL APU** circuit breaker (CB9). Check for short between (A76)J1-z and ground.  
**Does short exist?**

YES	Refer to TM 1-1520-238-T-6 to troubleshoot circuit protection system (dc emergency bus - pilot station).
NO	Go to step 2.

- Detach P176. Check for short between P176-m and ground.

**Does short exist?**

YES	Repair shorted wire between: P176-m and P916-E, P176-m and J16-C, J916-E and P463-z. Go to paragraph 15-12.
NO	Go to step 3.

- Check for  $3.5 \pm 0.5$  ohms between P176-e and ground.

**Is resistance present?**

YES	Go to step 6.
NO	Go to step 4.

- Check for  $6 \pm 1$  ohms between (L20): J1-1 and J1-5, J1-4 and J1-5.

**Is resistance present?**

YES	Go to step 5.
NO	Replace APU fuel shutoff valve (TM 55-1520-238-23).

- Check for  $6 \pm 1$  ohms between (L44)J1-1 and ground.

**Is resistance present?**

YES	Repair shorted wire between: P176-e and P488-B10, P444-A8 and P491-1, P444-A8 and P52-1. (A402): J18-B10 and TB2-12-C, TB2-12-D and J31-A8. Go to paragraph 15-12.
NO	Replace APU fuel boost pump (TM 55-1520-238-23).

- Check for short between P176-f and ground.  
**Does short exist?**

YES	Go to step 7.
NO	Go to step 8.

- Check for short between (L20)J1-4 and ground.  
**Does short exist?**

YES	Replace APU fuel shutoff valve (TM 55-1520-238-23).
NO	Repair shorted wire between: P176-f and P440-B18, P444-A2 and P52-4. (A402): J16-B18 and TB2-12-L, TB2-12-M and J31-A2. Go to paragraph 15-12.



---

**15-32. FUEL APU CIRCUIT BREAKER (CB9) - DOES NOT STAY CLOSED (cont) (cont)**

---

**15-32**

8. Detach P50. Check for short between P176-g and ground.

**Does short exist?**

- |     |  |
|-----|--|
| YES | Repair shorted wire between:<br>P176-g and J492-B,<br>P492-B and P50-20.<br>Go to paragraph 15-12. |
| NO  | Go to step 9.  |

9. Check for short between (A138):  
J1-g and chassis ground,  
J1-e and chassis ground,  
J1-f and chassis ground,  
J1-M and chassis ground.

**Does short exist?**

- |     |  |
|-----|--|
| YES | Replace <b>APU</b> fire test panel<br>(TM 55-1520-238-23).                   |
| NO  | Replace APU<br>temperature/speed sequence<br>controller (TM 55-1520-238-23). |

END OF TASK

**15-33. APU HOLD CIRCUIT BREAKER (CB10) - DOES NOT STAY CLOSED WITH START/RUN/OFF SWITCH SET TO RUN**

**15-33**

**Tools:**

<u>Nomenclature</u>	<u>Part Number</u>
Tool Kit, Electrical Repairer's	SC518099CLA06
Multimeter, Digital	AN/PSM-45

**Personnel Required:**

68X Armament/Electrical Systems Repairer

**References:**

TM 1-1520-238-T-6  
 TM 55-1520-238-23

**WARNING**

**Turn off power before detaching or attaching wires and connectors. High current 28 VDC or 115 VAC is present. Failure to do so could result in death or serious injury.**

1. On pilot **APU** fire test panel, set **START/RUN/OFF** switch to **RUN**, check for short between (A138)J1-Z and ground.  
**Does short exist?**

YES	Replace pilot <b>APU</b> fire test panel (TM 55-1520-238-23).
NO	Go to step 2.
  
2. Check for 4000 ±400 ohms between P176-g and ground.  
**Is resistance present?**

YES	Go to step 4.
NO	Go to step 3.

3. Detach P50. Check for short between P176-g and ground.  
**Does short exist?**

YES	Repair shorted wire between: P176-g and J492-B, P492-B and P50-20. Go to paragraph 15-12.
NO	Replace APU temperature/speed sequence controller (TM 55-1520-238-23).
  
4. Check for 20K ±2K ohms between P176-a and ground.  
**Is resistance present?**

YES	Refer to TM 1-1520-238-T-6 to troubleshoot circuit protection system (dc emergency bus - pilot station).
NO	Go to step 5.
  
5. Detach P688. Check for short between P176-a and ground.  
**Does short exist?**

YES	Go to step 6.
NO	Replace DASEC (TM 55-1520-238-23).
  
6. Detach P50 and P688. Check for short between P176-a and ground.  
**Does short exist?**

YES	Repair shorted wire between: P176-a and J492-A, P492-A and P50-11, P492-A and P910-B15, P910-B15 and P688-13. Go to paragraph 15-12.
NO	Replace APU temperature/speed sequence controller (TM 55-1520-238-23).

END OF TASK

**15-34. APU CIRCUIT BREAKER (CB148) - DOES NOT STAY CLOSED**

**15-34**

**Tools:**

<u>Nomenclature</u>	<u>Part Number</u>
Tool Kit, Electrical Repairer's	SC518099CLA06
Multimeter, Digital	AN/PSM-45

**Personnel Required:**

68X Armament/Electrical Systems Repairer  
One person to assist

**References:**

TM 1-1520-238-T-6

2. Check for short between:

CB10 and ground,  
P430-A4 and ground,  
CB148 and ground,  
P463-h and ground,  
P433-A19 and ground.  
(A76)J1-h and ground.  
(A402):

J20-A19 and ground,  
TB2-33-N and ground,  
TB2-33-P and ground,  
J6-A4 and ground.

**Does short exist?**

YES	Repair shorted wire. Go to paragraph 15-12.
NO	Refer to TM 1-1520-238-T-6 to troubleshoot circuit protection system (dc emergency bus - pilot station).



**Turn off power before detaching or attaching wires and connectors. High current 28 VDC or 115 VAC is present. Failure to do so could result in death or serious injury.**

1. On pilot center circuit breaker panel, open **APU HOLD** circuit breaker (CB10). In aft avionics bay close **APU** circuit breaker (CB148).

**Does circuit breaker stay closed?**

YES	Go to paragraph 15-33.
NO	Go to step 2.

END OF TASK

15-35. APU DOES NOT START

15-35

**Tools:**

<u>Nomenclature</u>	<u>Part Number</u>
Tool Kit, Electrical Repairer's	SC518099CLA06
Multimeter, Digital	AN/PSM-45
Pail, Utility	A-A-1273

**Personnel Required:**

68X Armament/Electrical Systems Repairer  
One person to assist

**References:**

TM 1-1520-238-23

**Equipment Conditions:**

<u>Ref</u>	<u>Condition</u>
TM 1-1520-238-23	APU fuel inlet hose disconnected from APU fuel control unit

**WARNING**

**Turn off power before detaching or attaching wires and connectors. High current 28 VDC or 115 VAC is present. Failure to do so could result in death or serious injury.**

- With P50 detached from (A6)J1, and APU fuel inlet hose placed in pail. On pilot **APU** fire test panel, set **START/RUN/OFF** switch to **RUN**.  
**Does fuel flow from APU fuel inlet line?**

YES      Go to step 4.  
NO        Go to step 2.

- Have assistant check APU fuel pump for operating noise.

**Is a high pitched whine present?**

YES      Replace APU fuel pump (TM 1-1520-238-23).  
NO        Go to step 3.

- Remove APU fuel inlet hose and check for obstruction.

**Is there an obstruction?**

YES      Replace APU fuel inlet hose (TM 1-1520-238-23).  
NO        Replace 4-way check valve in aft fuel cell (TM 1-1520-238-23).

- Check for 28 VDC at P51-1.

**Is voltage present?**

YES      Go to step 5.  
NO        Go to paragraph 15-21 to troubleshoot PTO clutch.

- Check APU hydraulic start motor for defects.

**Is start motor defective?**

YES      Replace APU hydraulic start motor (TM 1-1520-238-23).  
NO        Replace APU starter solenoid valve (TM 1-1520-238-23).

END OF TASK

**15-36. APU HOLD CIRCUIT BREAKER (CB10) - DOES NOT STAY CLOSED WITH START/RUN/OFF SWITCH SET TO OFF**

15-36

**Tools:**

<u>Nomenclature</u>	<u>Part Number</u>
Tool Kit, Electrical Repairer's	SC518099CLA06
Multimeter, Digital	AN/PSM-45

**Personnel Required:**

68X Armament/Electrical Systems Repairer

**References:**

TM 1-1520-238-T-6  
 TM 55-1520-238-23

3. Detach P916. Check for short between P916-D and ground.

**Does short exist?**

YES	Repair shorted wire between P916-D and P176-Z. Go to paragraph 15-12.
NO	Repair shorted wire between J916-D and P463-B. Go to paragraph 15-12.

**WARNING**

**Turn off power before detaching or attaching wires and connectors. High current 28 VDC or 115 VAC is present. Failure to do so could result in death or serious injury.**

1. Detach P176. Check for short between P176-Z and ground.

**Does short exist?**

YES	Go to step 2.
NO	Replace pilot <b>APU</b> fire test panel (TM 55-1520-238-23).

2. Detach P463. Check for short between (A76)J1-B and ground.

**Does short exist?**

YES	Refer to TM 1-1520-238-T-6 to troubleshoot circuit protection system (dc emergency bus - pilot station).
NO	Go to step 3.

END OF TASK



# CHAPTER 16 MISSION EQUIPMENT

## CHAPTER INDEX

<u>Para Title</u>	<u>Para No.</u>
<b>SECTION I. EQUIPMENT DESCRIPTION AND DATA</b>	
Equipment Characteristics, Capabilities, and Features .....	16-1
Location and Description of Major Components .....	16-2
Equipment Data .....	16-3
Equipment Configuration .....	16-4
Safety, Care and Handling of Equipment .....	16-5
Controls and Indicators .....	16-6
<b>SECTION II. THEORY OF OPERATION</b>	
System Description .....	16-7
Multiplex Read Codes .....	16-8
<b>SECTION III. TROUBLESHOOTING PROCEDURES</b>	
Electrical Component Location and Configuration (ECLC) Index .....	16-9
External Stores - Power Up .....	16-10
External Stores - Power Down .....	16-11
External Stores Elevation Control - Maintenance Operational Check .....	16-12
External Stores Elevation Control - Wiring Interconnect Diagram .....	16-13
External Stores Jettison - Maintenance Operational Check .....	16-21
External Stores Jettison - Wiring Interconnect Diagram .....	16-22

## SECTION I. EQUIPMENT DESCRIPTION AND DATA

---

### 16-1. EQUIPMENT CHARACTERISTICS, CAPABILITIES, AND FEATURES

---

16-1

#### a. Characteristics.

(1) **External Stores Elevation Control System.** The external stores elevation control system provides mounting and positional control of external stores.

(2) **External Stores Jettison System.** The external stores jettison system enables the pilot and copilot/gunner (CPG) to jettison external stores from the helicopter.

#### b. Capabilities and Features.

(1) **External Stores Elevation Control System.** The external stores elevation control system is capable of positioning external stores, with the exception of fuel tanks, to any desired position within the following limits:

- +4° up elevation limit (flight stow).
- -5° down elevation (ground stow).
- -15° down elevation (travel limit).

(2) **External Stores Jettison System.** The pilot can jettison all stores simultaneously or select any one or a combination of stores to jettison. The CPG can jettison all stores simultaneously.

---

### 16-2. LOCATION AND DESCRIPTION OF MAJOR COMPONENTS

---

16-2

a. **External Stores Elevation Control System.** The external stores elevation control system consists of 4 pylon actuators, 4 pylon actuator controllers and an external stores elevation controller.

(1) **Pylon Actuator.** The pylon actuator (fig. 16-1), located in the center section of each pylon frame assembly, sets the tilt angle of the pylon.

(2) **Pylon Actuator Controller.** The pylon actuator controller, located in the aft section of each pylon frame assembly, controls and monitors the position of the pylon actuator.

(3) **External Stores Elevation Controller.** The external stores elevation controller, located in the left hand forward ammunition bay, controls the operation of the 4 pylon actuator controllers.

b. **External Stores Jettison System.** The external stores jettison system (fig. 16-2) consists of 4 rack assemblies, 4 ejector assemblies, 4 suspension hook assemblies.

(1) **Rack Assembly.** The rack assembly, attached to the pylon assembly of each wing, contains a suspension hook assembly for attaching external stores to the helicopter.

(2) **Ejector Assembly.** The ejector assembly, located within the rack assembly, provides the means of unlocking the suspension hook assembly and pushing the external stores away from the helicopter.

(3) **Suspension Hook Assembly.** The suspension hook assembly, located within the rack assembly, holds and locks the external stores to the rack assembly.



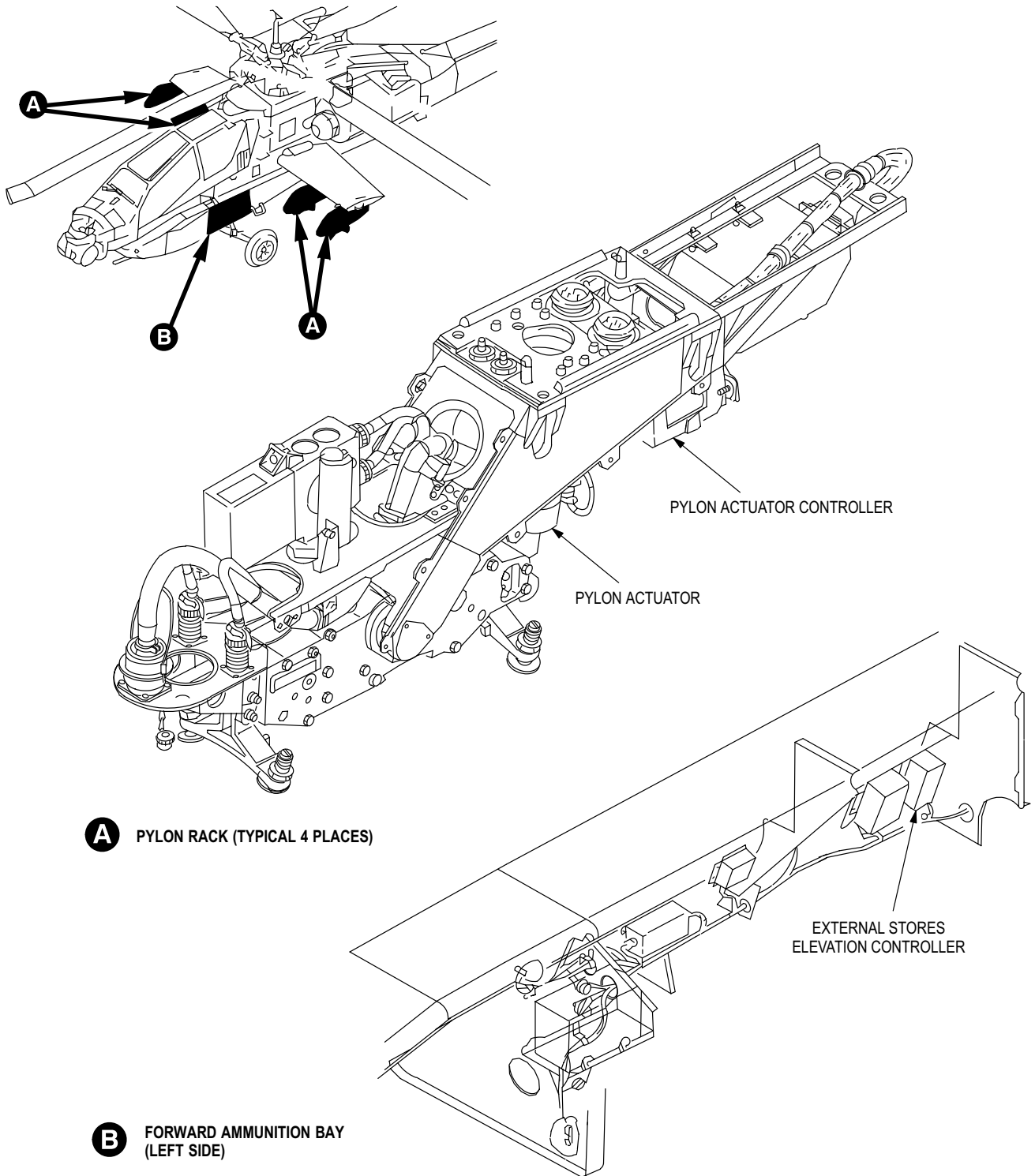

M71-189

Figure 16-1. External Stores Elevation Control Major Components Location

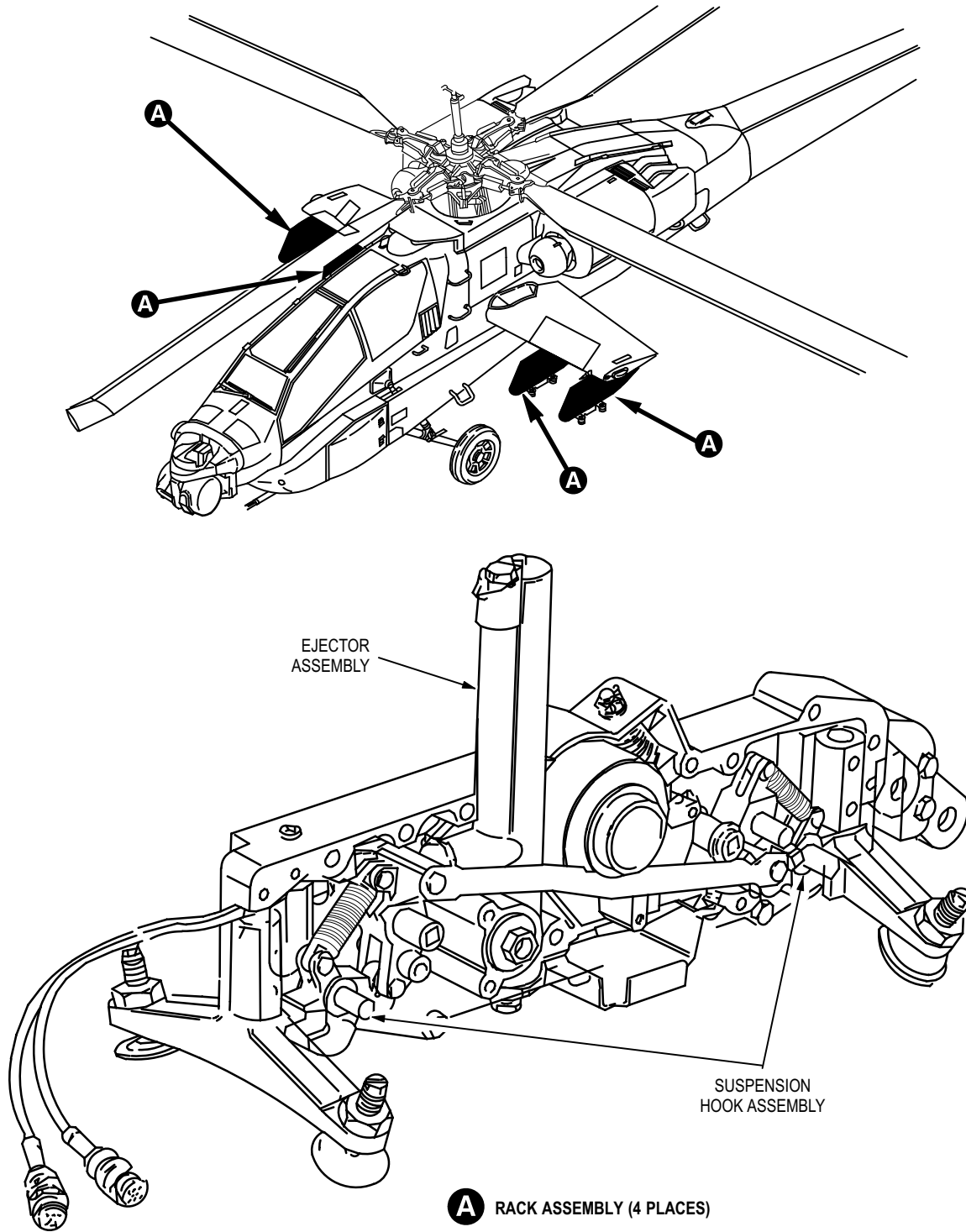

Figure 16-2. External Stores Jettison System Components Location

M71-196

---

**16-3. EQUIPMENT DATA**

---

**16-3**

Electrical requirements

DC power requirement ..... 28 VDC

AC power requirement ..... 115 VAC, single phase, 400 Hz

Hydraulic requirement ..... 3000 psi

---

**16-4. EQUIPMENT CONFIGURATION**

---

**16-4**

Not applicable.

---

**16-5. SAFETY, CARE AND HANDLING OF EQUIPMENT**

---

**16-5**

Not applicable.

---

**16-6. CONTROLS AND INDICATORS**

---

**16-6**

The external stores system receives mode selects and remote switch inputs from various controls located within the pilot station (fig. 16-3) and CPG station (fig. 16-4). Table 16-1 provides a listing of the controls, switches and associated indicators pertaining to the mission equipment system along with a description of their function.

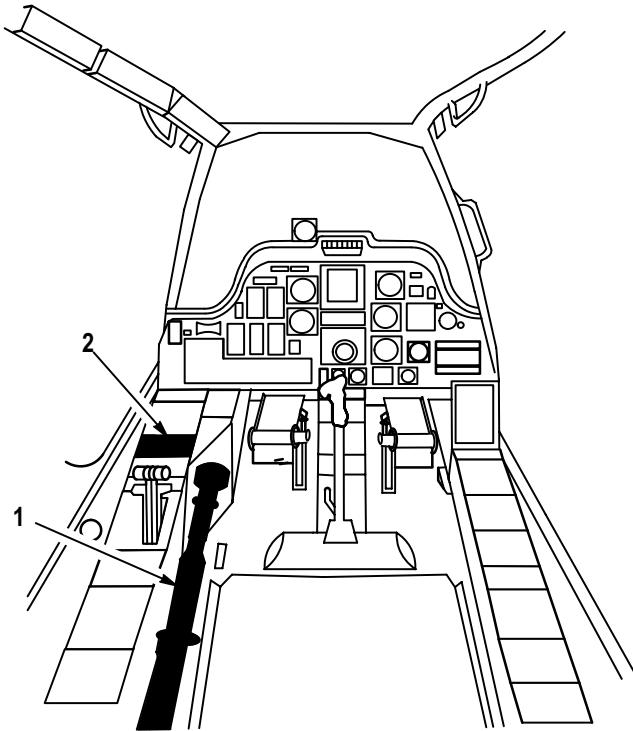

1. PILOT COLLECTIVE STICK  
2. PILOT STORES JETT PANEL

M71-198

Figure 16-3. Pilot Station

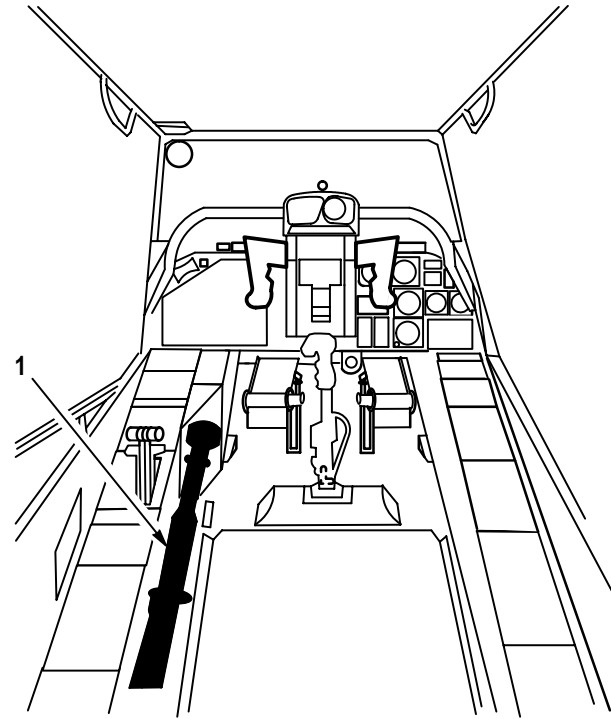

1. CPG COLLECTIVE STICK

M71-199

Figure 16-4. CPG Station

Table 16-1. Mission Equipment Controls and Indicators

Pylon Actuating Switch		
SWITCH/INDICATOR	POSITION	FUNCTION
PYLON ACTG SW	UP	Positions pylons to +4° for flight stow.
	OFF	De-energizes pylon for normal position.
	DOWN	Positions pylons to -5° for ground stow.

Table 16-1. Mission Equipment Controls and Indicators (cont)

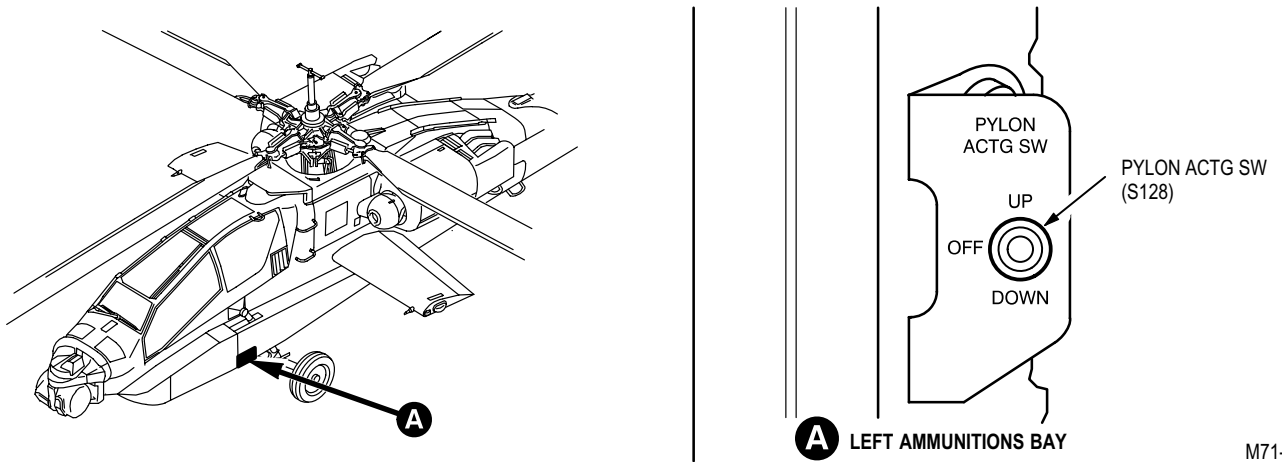

M71-190

**Pylon Actuating Switch**

Collective Stick		
SWITCH/INDICATOR	POSITION	FUNCTION

**ST JTSN** switch

Jettisons external stores simultaneously on all 4 pylons.

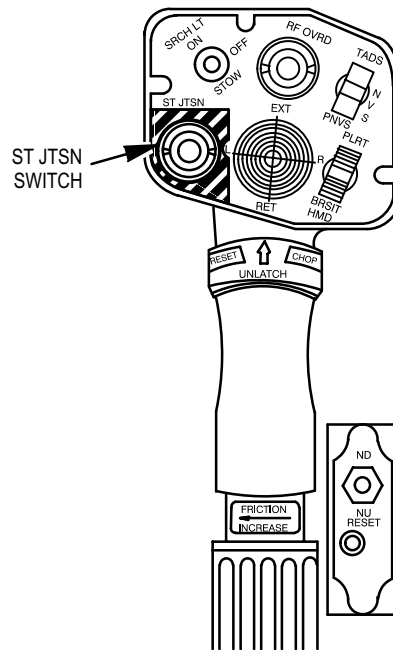

**Collective Stick**

M71-200

Table 16-1. Mission Equipment Controls and Indicators (cont)

Pilot STORES JETT Panel		
SWITCH/INDICATOR	POSITION	FUNCTION

STORES JETT L OUTBD switch		Jettisons left outboard external stores.
STORES JETT L INBD switch		Jettisons left inboard external stores.
STORES JETT R INBD switch		Jettisons right inboard external stores.
STORES JETT R OUTBD switch		Jettisons right outboard external stores.

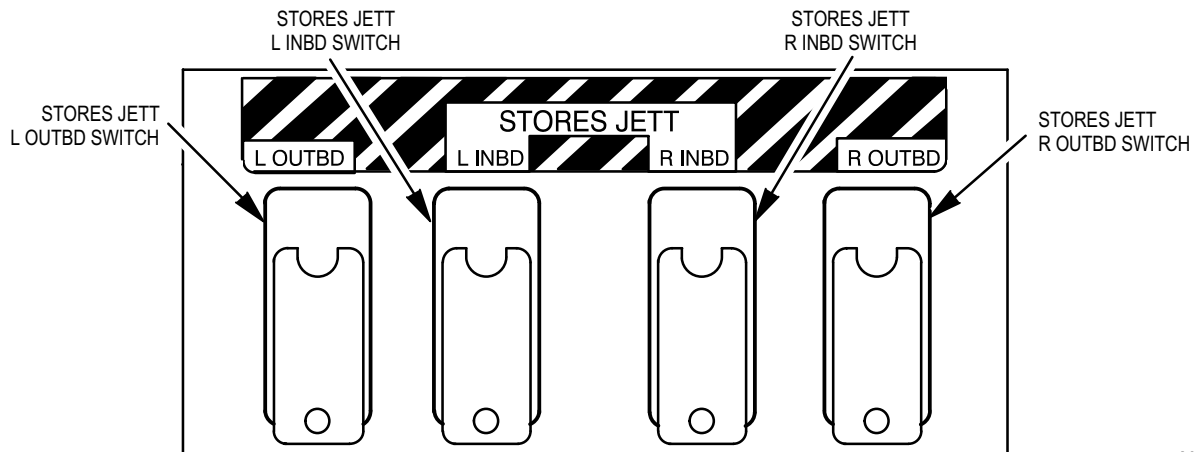

M71-201

Pilot STORES JETT Panel

## SECTION II. THEORY OF OPERATION

a. **External Stores.** The external stores system (fig. 16-5) provides mounting and position control of the external stores. The system also provides the means to jettison any or all stores.

16-7. SYSTEM DESCRIPTION (cont)

16-7

(1) The pylon assemblies attach to the wings of the aircraft and provide for mounting and articulation of the rack assemblies. The rack assemblies are attached to the pylons and provide for mounting and jettison capability of external stores. The 4 external stores can be any one or combination of hellfire missile launchers, 2.75 inch rocket launchers, or external fuel tanks. Articulation is provided by the external stores controller, except for the external fuel tanks which are disabled at the time of installation by disconnecting the actuators.

(2) The pilot can jettison any one or combination of external stores from the stores jettison panel. Either the pilot or CPG can jettison all external stores using the **ST JTSN** switch on the collective stick.

(3) A **PYLON ACTG SW** is provided to permit maintenance personnel to articulate the pylons from outside the aircraft.

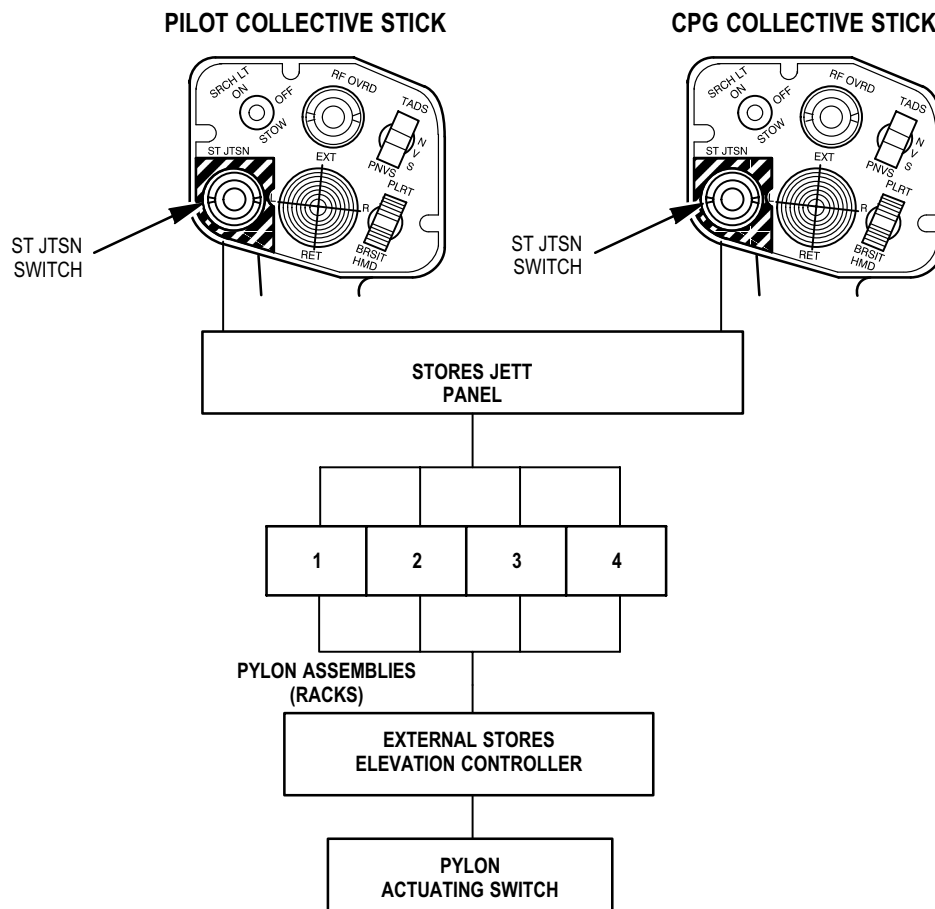

M71-311

Figure 16-5. External Stores Operation

b. External Stores Elevation Control System.

(1) **Purpose.** The purpose of the external stores elevation control system is to provide mounting and positioning of any symmetrical combination of missile launchers, rocket pods or external fuel tanks.

(2) **System Operation** (fig. 16-6). **MISSION EL AC** circuit breaker (CB92) provides 115 VAC to the external stores elevation controller. **MISSION EL DC** circuit breaker (CB91) supplies 28 VDC to the external stores elevation controller. The external stores elevation controller then supplies +15 VDC, -15 VDC, and +28 VDC power to the 4 pylon actuator controllers.

(a) **COMM IFF** circuit breaker (CB26) supplies 28 VDC to the squat relay and squat switch. When the helicopter is on the ground the pylons are commanded to ground stow (-5°). When the helicopter is airborne, the pylons are commanded to go to flight stow (+4°).

(b) **MISSION ARM CONTROL** circuit breaker (CB46) supplies 28 VDC to the **PYLON ACTG SW**. The **PYLON ACTG SW** commands either an **UP** or **DOWN** input to the external stores elevation controller. The **UP** position commands the pylons to flight stow (+4°) and the **DOWN** position commands the pylons to ground stow (-5°).

(c) Pilot or CPG **RKT GND STOW** or **RKT** action signals via the fire control panels command the pylons to go to ground stow. Pilot and CPG **RKT NORM**, **MSL** enable, and **MSL** action signals via the fire control panels as well as elevation command and elevation rate inputs from the FCC via MRTU type I, command the pylons to the desired position.

(d) The external stores elevation controller monitors airspeed input from the air data system via the MRTU type I. When the airspeed is above 100 knots the external stores controller commands the pylons to flight stow regardless of other inputs. System and line replaceable units (LRUs) are monitored and the status is reported to the FCC via the MRTU type I. The external stores elevation controller sends an unlock command and an elevation command to the 4 pylon actuator controllers. The 4 pylon actuator controllers send a servo drive signal to the 4 pylon actuators. The pylon actuators position the pylons using 3000 psi from the utility hydraulic system and provide feedback information to the pylon actuator controllers. The pylon actuator controllers output LVDT position information and LRU status to the FCC via the respective MRTU type II.

#### c. External Stores Jettison System.

(1) **Purpose.** The purpose of the external stores jettison system is to provide a means for jettisoning all or a selected combination of missile launchers, rocket pods or external fuel tanks.

(2) **System Operation** (fig. 16-7). **JETT** circuit breaker (CB34) supplies 28 VDC to the pilot and CPG collective **ST JTSN** switches. **MISSION JETT** circuit breaker (CB89) supplies 28 VDC to the pilot **STORES JETT** panel. When the pilot or CPG presses the **ST JTSN** switch, 28 VDC is routed through pilot **STORES JETT** panel and applied through resistor assemblies to fire all 4 squibs. The **STORES JETT** panel allows selection of any external store or a combination of external stores to be jettisoned. When the pilot lifts the guard and engages the selected switch(es) on the **STORES JETT** panel, 28 VDC is applied through a resistor assembly firing the selected squib(s). The squibs are located in the ejector assembly. When the squib is fired, the ejector assembly unlocks the hook assembly, jettisoning the stores downward and away from the helicopter.



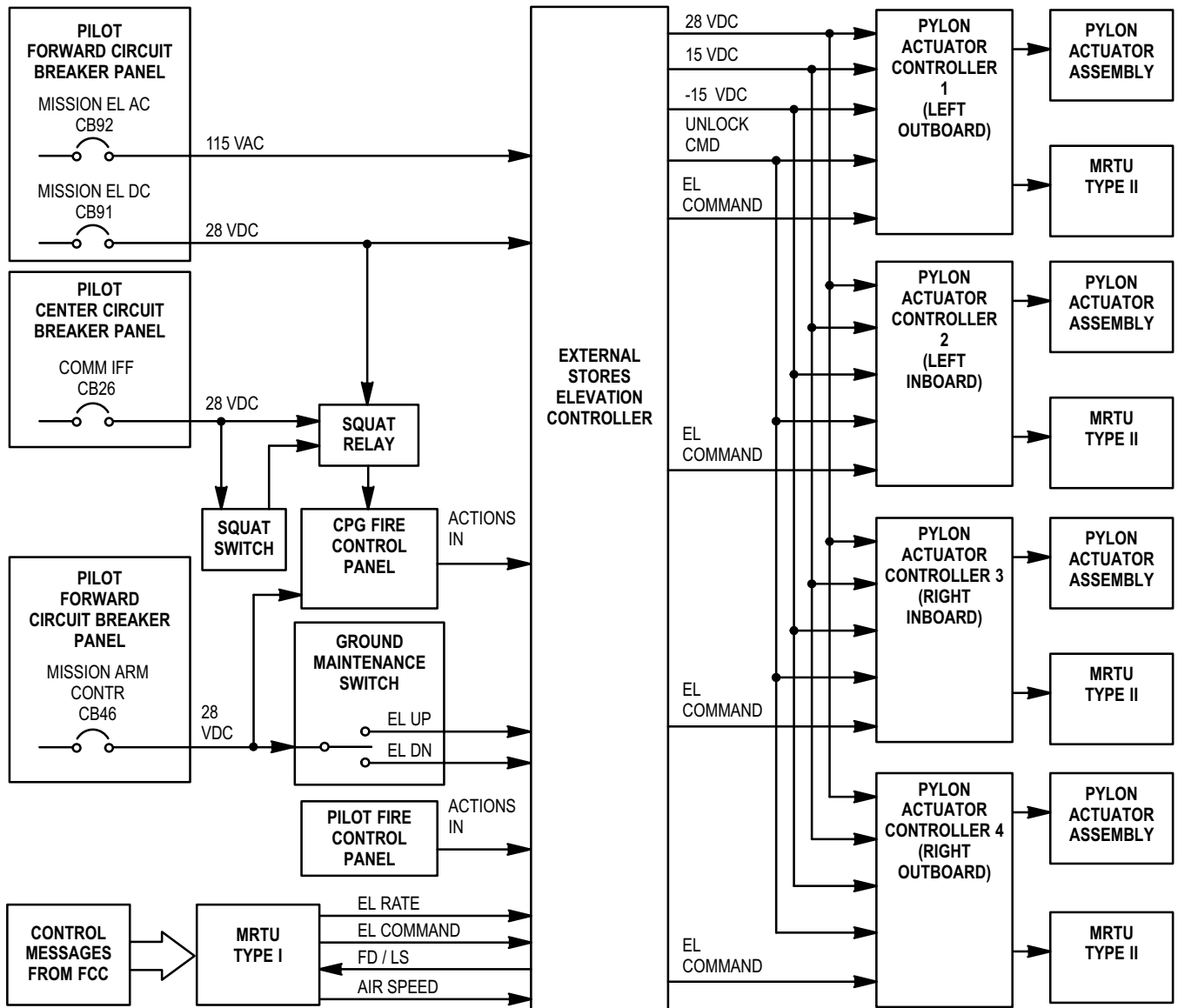

M71-239A

Figure 16-6. External Stores Elevation Control Functional Block Diagram

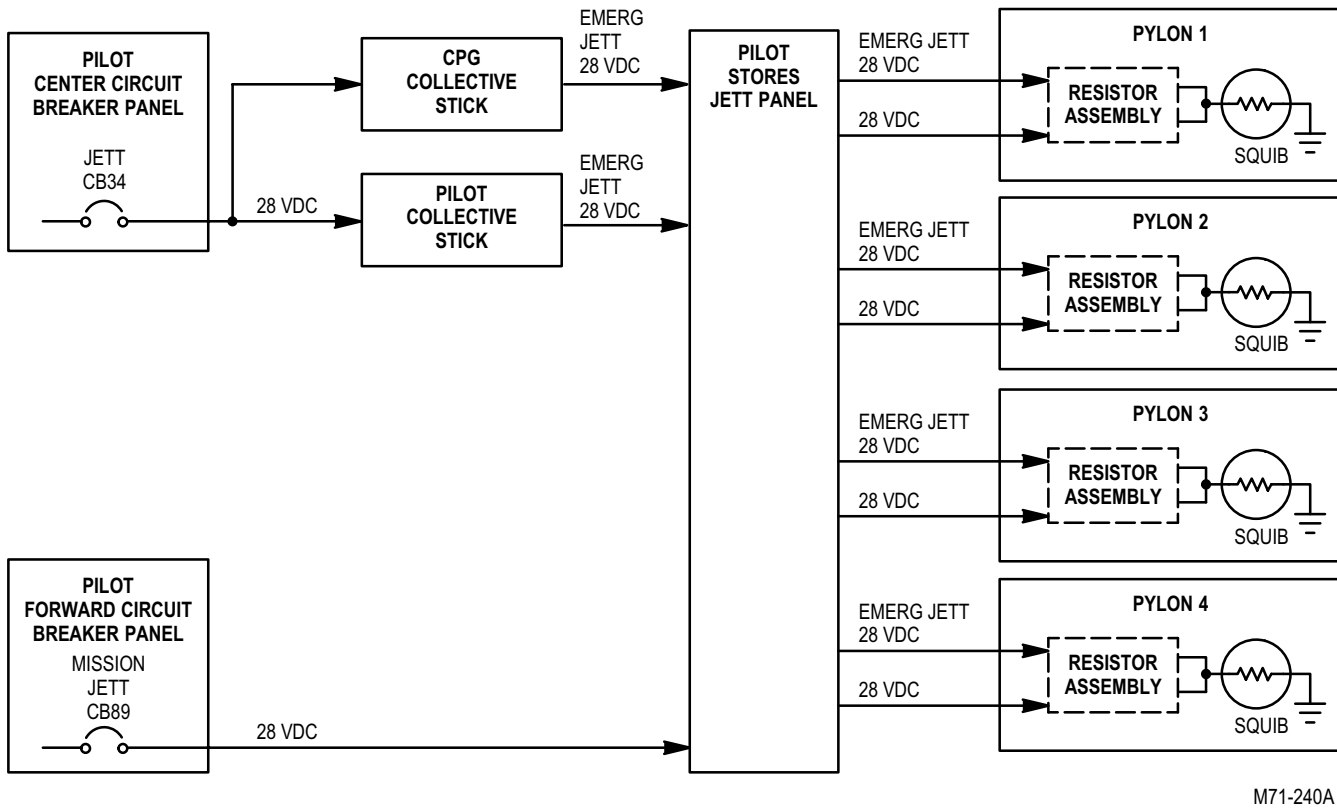

Figure 16-7. External Stores Jettison Functional Block Diagram

The external stores elevation controller communicates with the FCC. The FCC uses multiplex codes to issue instructions and to determine system/LRU status. See TM 1-1520-238-T-3, Multiplex Read Codes, for help in using these codes to troubleshoot the external stores elevation control.

## SECTION III. TROUBLESHOOTING PROCEDURES

## 16-9. ELECTRICAL COMPONENT LOCATION AND CONFIGURATION (ECLC) INDEX

16-9

Use the information in Table 16-2 to locate the electrical components and their connectors that you have to locate to perform the troubleshooting tasks in this chapter. Table 16-2 includes locator illustrations which supplement the 16-2 listing. The entry in the grid area column in the listing tells you where to locate the component in the illustrations.

*Table 16-2. Electrical Component and Configuration (ECLC) Index Listing*

FROM COLUMN		TO COLUMN		Grid Area	Access
Connector Ref Des	Component/Harness	Connector Ref Des	Component/Harness		
P1	W605	J1	A402	36A	PLT STATION
P107	A81	J107	W119	26B	PLT STATION
P108	W119	J108	A80	14B	CPG STATION
P2	W605	J2	A402	36C	PLT STATION
P277	W117	J1	A102	20E	PLT STATION
P279	W117	J1	A156	4E	L40 COVER
P280	W255	J2	A156	4D	L40 COVER
P281	W117	J3	A156	4E	L40 COVER
P407	W255	J407	W255	4C	L40 COVER
P411	W117	J411	W255	4C	L40 COVER
P418	W117	J418	W255	8C	R60 FAIRING
P433	W119	J20	A402	35E	PLT STATION
P441	W119	J24	A402	35D	PLT STATION
P453	W117	J14	A402	33D	PLT STATION
P457	W119	J22	A402	35E	PLT STATION
P458	W116	J458	W117	25C	PLT STATION
P463	W119	J1	A76	28D	PLT STATION
P471	W117	J1	A326	23C	CPG STATION
P478	W116	J17	A402	34C	L200
P483	W117	J26	A402	35D	L200

Table 16-2. Electrical Component Location and Configuration (ECLC) Index Listing (cont)

FROM COLUMN		TO COLUMN		Grid Area	Access
Connector Ref Des	Component/Harness	Connector Ref Des	Component/Harness		
P501	W117	J501	A37	39B	L117 DOOR
P502	W117	J502	A37	39B	L117 DOOR
P503	W117	J1	A94	32C	PLT STATION
1P505	W601	1J505	A333	45D	LW10 FAIRING
2P505	W601	2J505	A333	47D	LW10 FAIRING
3P505	W601	3J505	A333	46B	RW10 FAIRING
4P505	W601	4J505	A333	47B	RW10 FAIRING
P506	W601	J506	A82	44C	P2 FAIRING
P507	W601	J507	A90	44B	P2 FAIRING
P516	W601	J7	1A68	44E	P2 FAIRING
P586	W157	J586	W117	48E	LW10 FAIRING
P587	W157	J587	W117	48E	LW10 FAIRING
P588	W157	J588	A333	45A	LW10 FAIRING
P589	W158	J589	W116	45A	RW10 FAIRING
P671	W116	J4	A62	7C	R60 FAIRING
P673	W117	J3	A63	9C	L90 DOOR
P674	W117	J4	A63	9C	L90 DOOR
P685	W117	J2	A63	10C	L90 DOOR
P921	W117	J921	A37	13C	CPG STATION

16-9. ELECTRICAL COMPONENT LOCATION AND CONFIGURATION (ECLC) INDEX (cont)

16-9

Table 16-2. Electrical Component Location and Configuration (ECLC) Index Listing (cont)

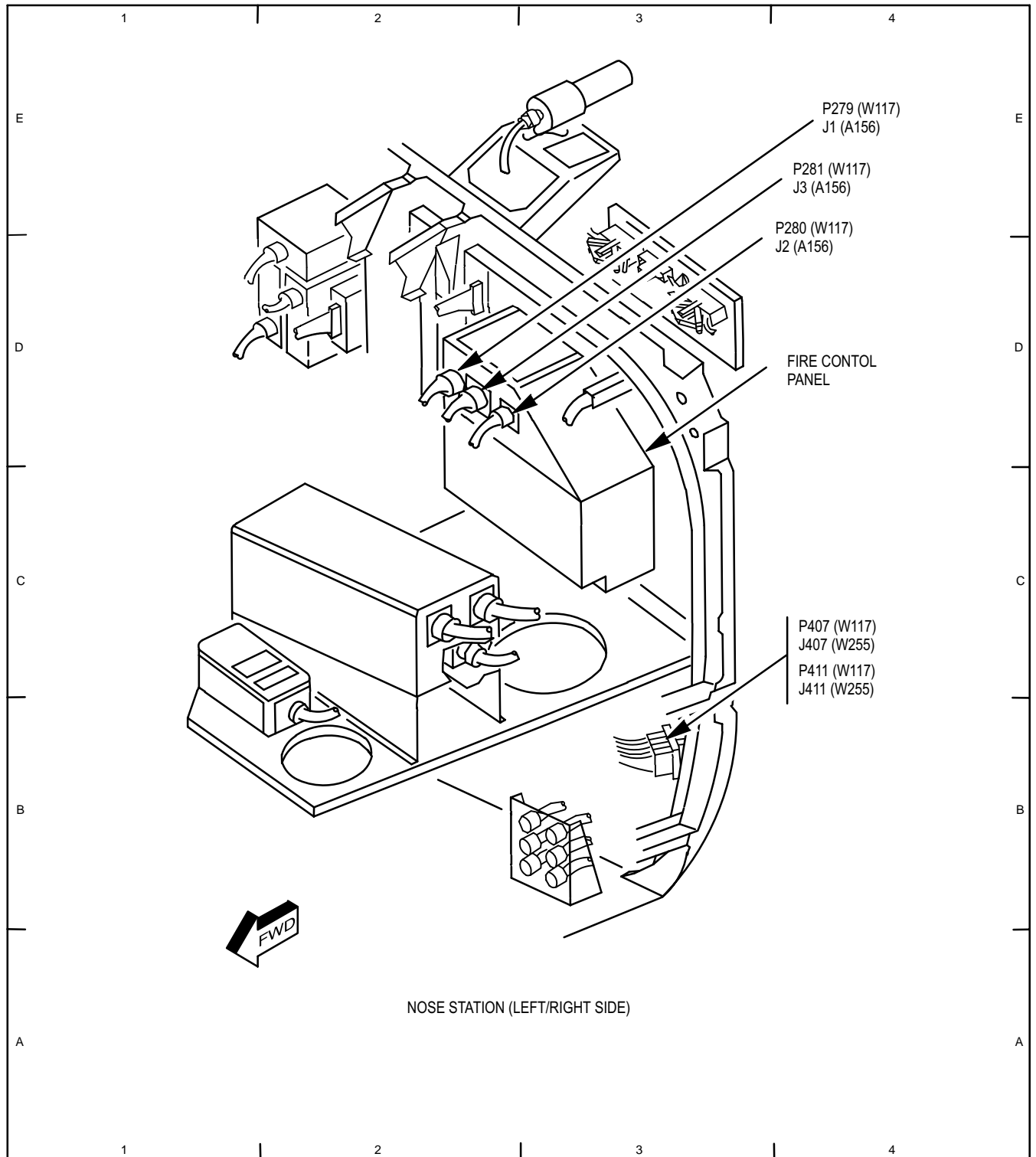

M71-301

Table 16-2. Electrical Component Location and Configuration (ECLC) Index Listing (cont)

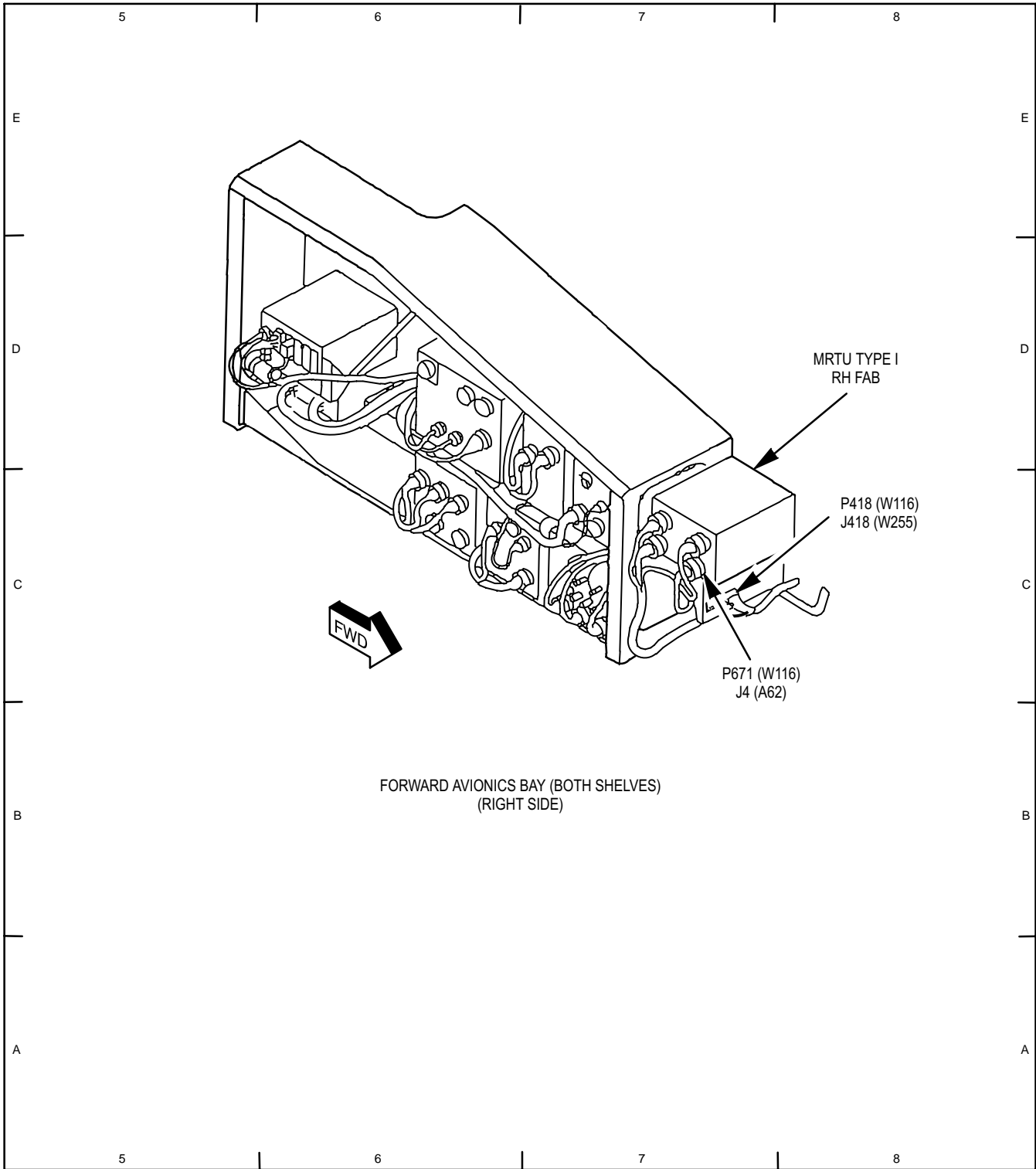

M71-250A

16-9. ELECTRICAL COMPONENT LOCATION AND CONFIGURATION (ECLC) INDEX (cont)

16-9

Table 16-2. Electrical Component Location and Configuration (ECLC) Index Listing (cont)

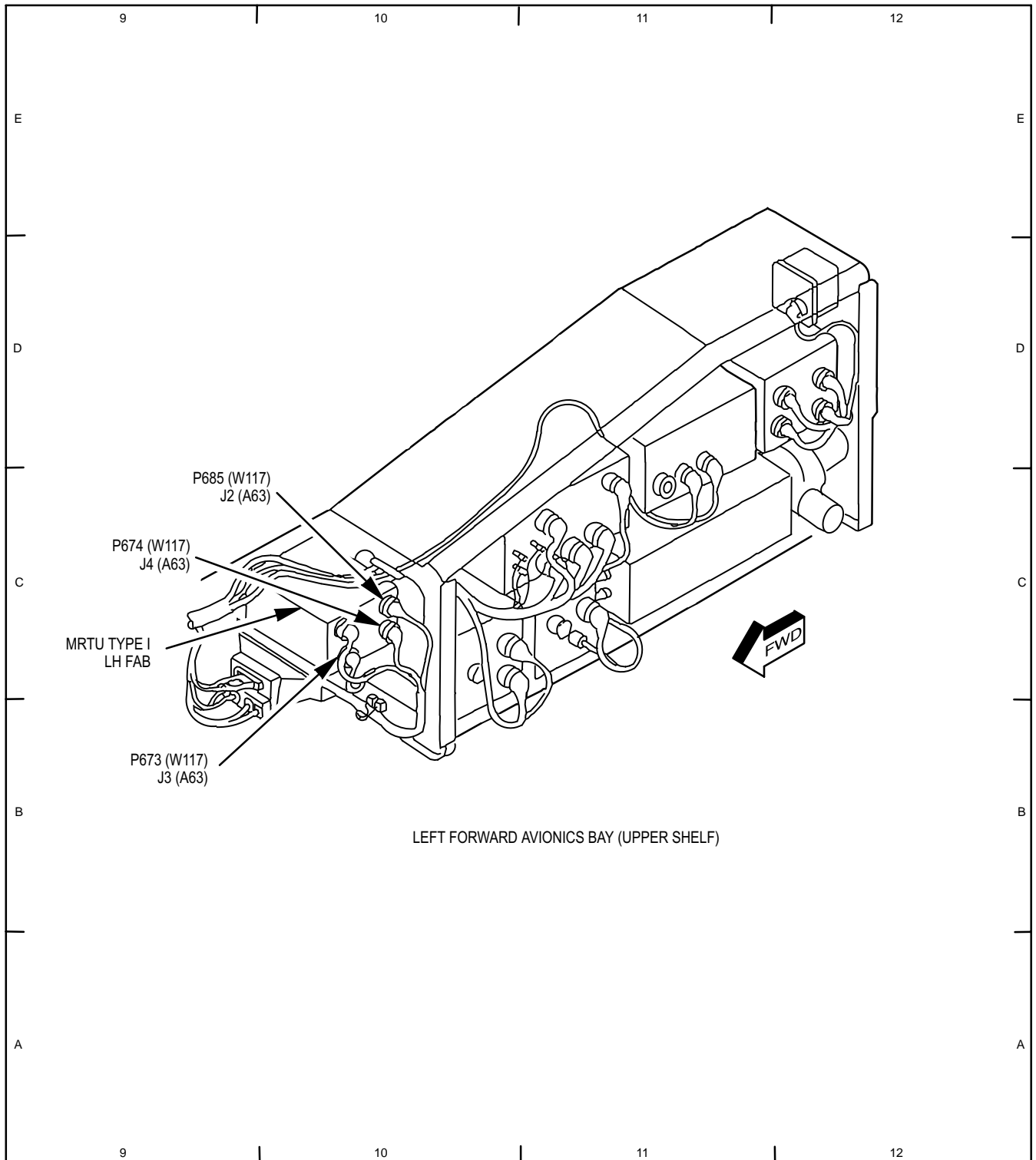

M71-302

Table 16-2. Electrical Component Location and Configuration (ECLC) Index Listing (cont)

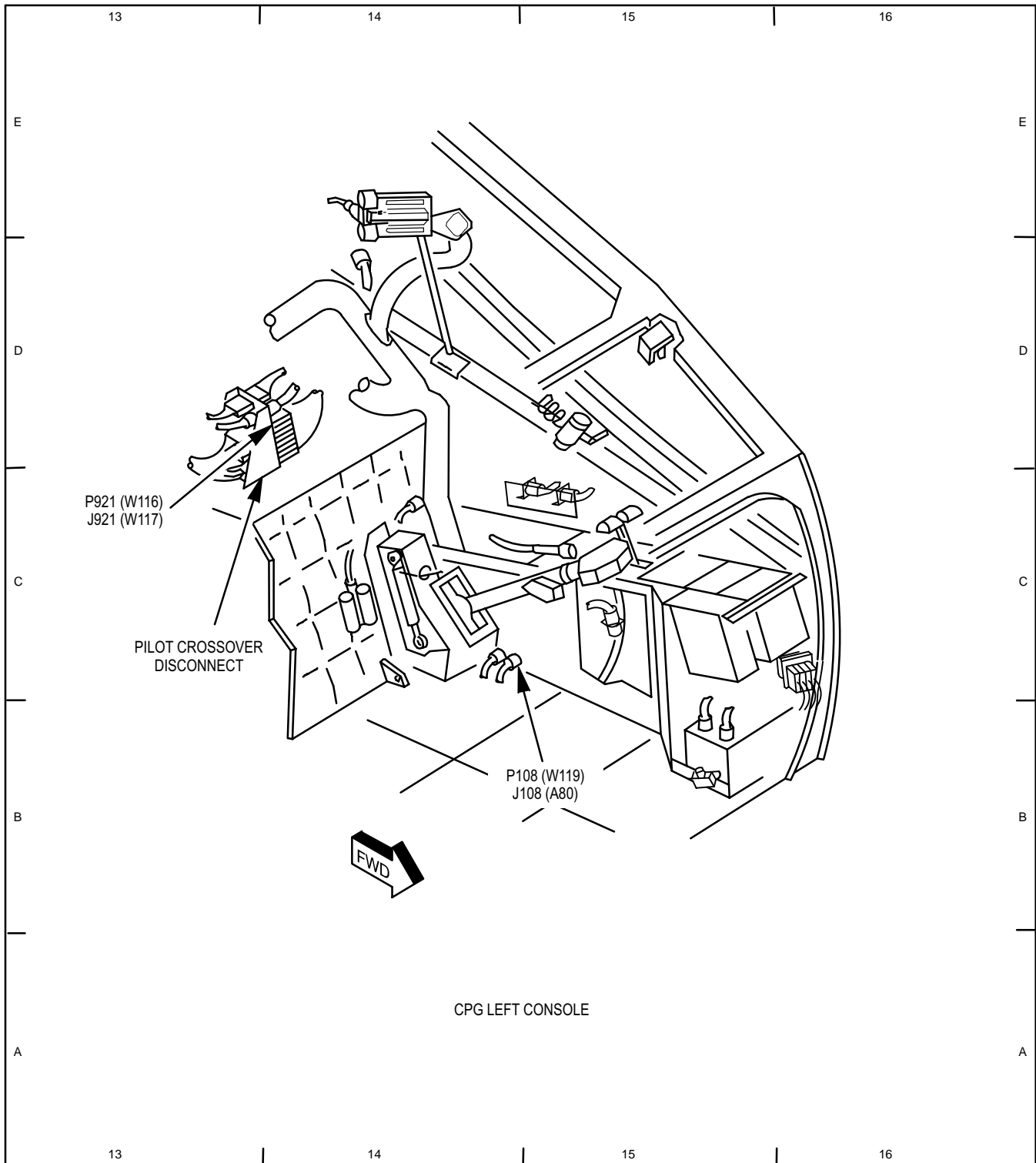

M71-303



16-9. ELECTRICAL COMPONENT LOCATION AND CONFIGURATION (ECLC) INDEX (cont)

16-9

Table 16-2. Electrical Component Location and Configuration (ECLC) Index Listing (cont)

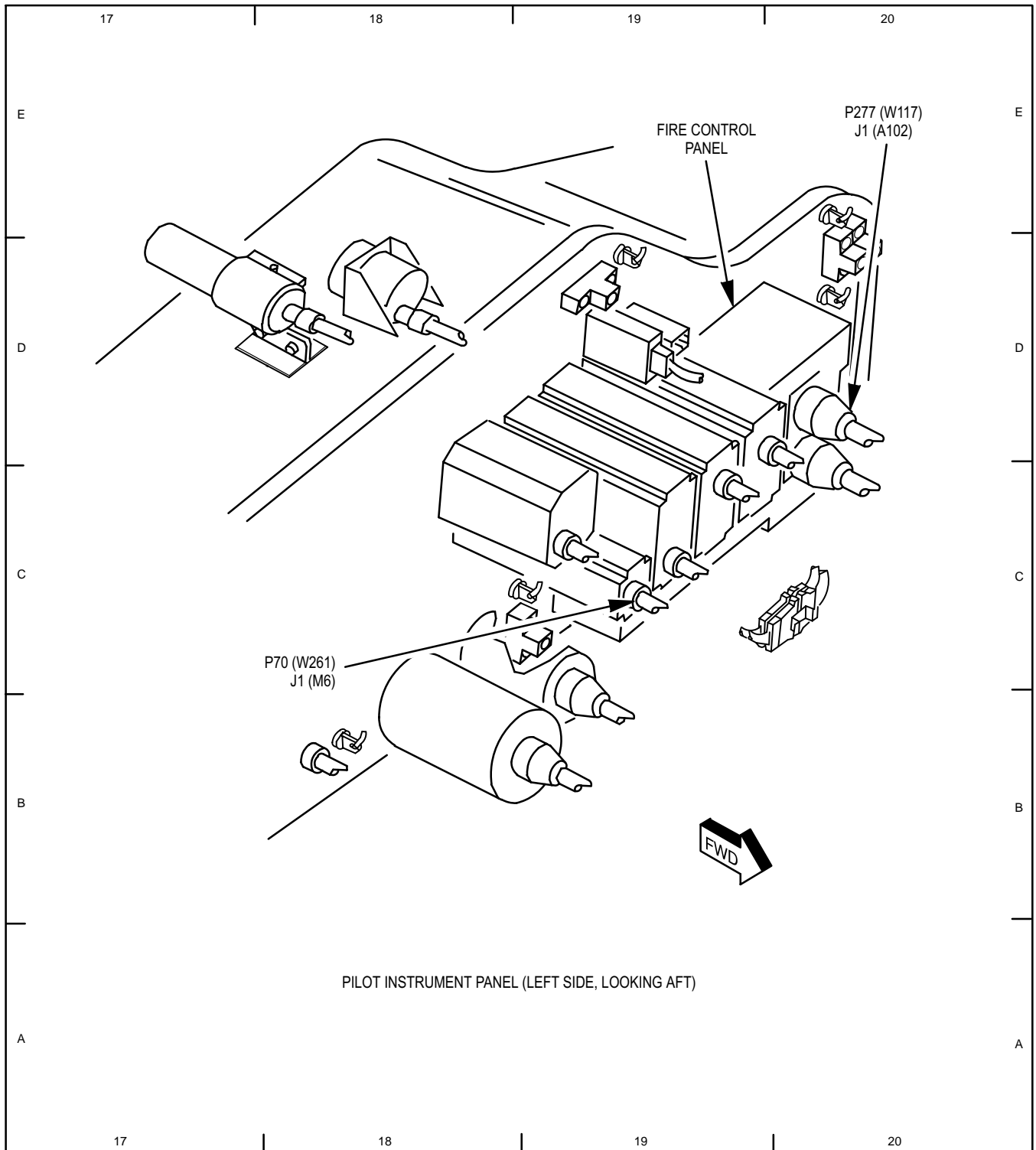

M71-304

Table 16-2. Electrical Component Location and Configuration (ECLC) Index Listing (cont)

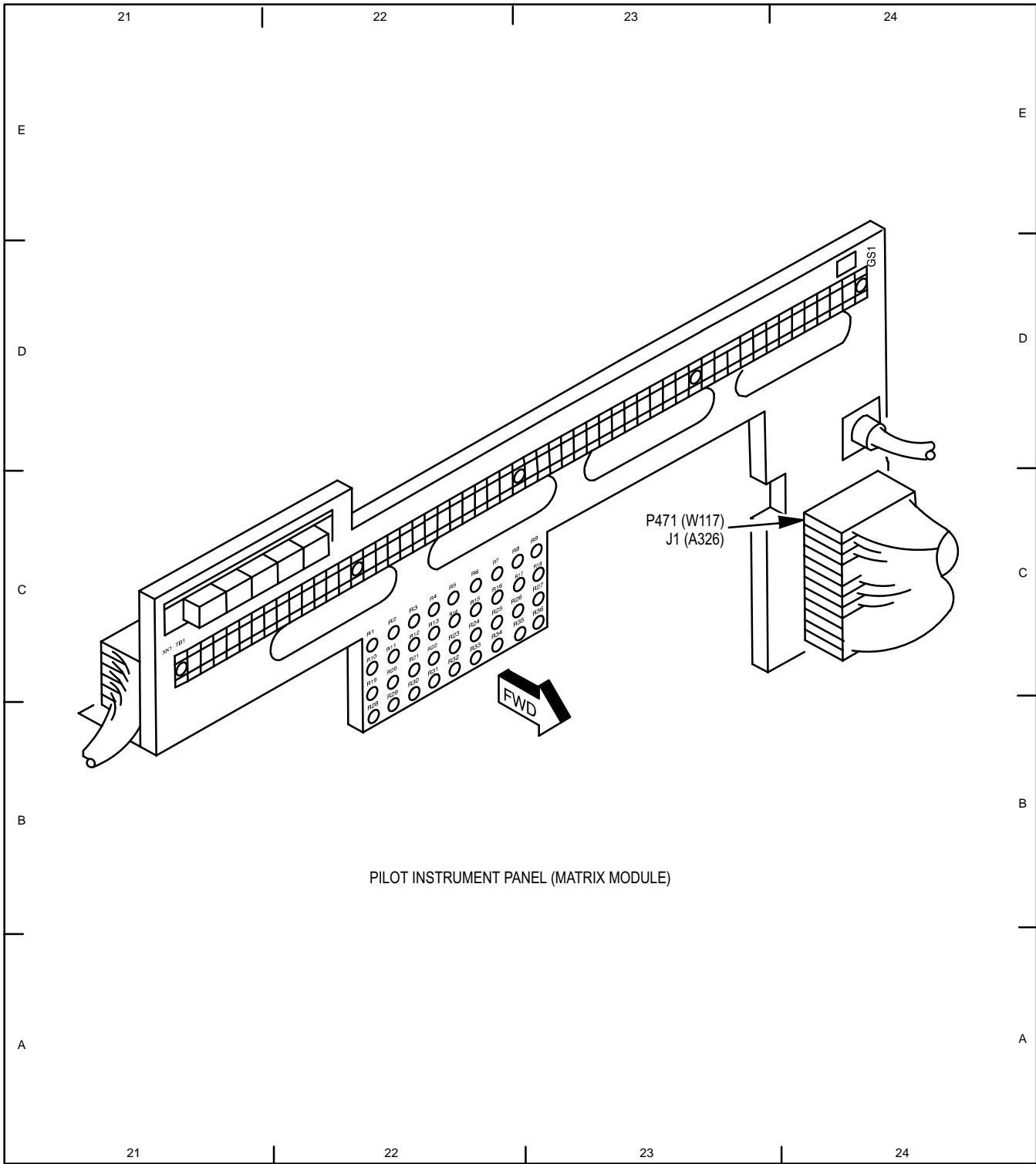

M71-305

16-9. ELECTRICAL COMPONENT LOCATION AND CONFIGURATION (ECLC) INDEX (cont)

16-9

Table 16-2. Electrical Component Location and Configuration (ECLC) Index Listing (cont)

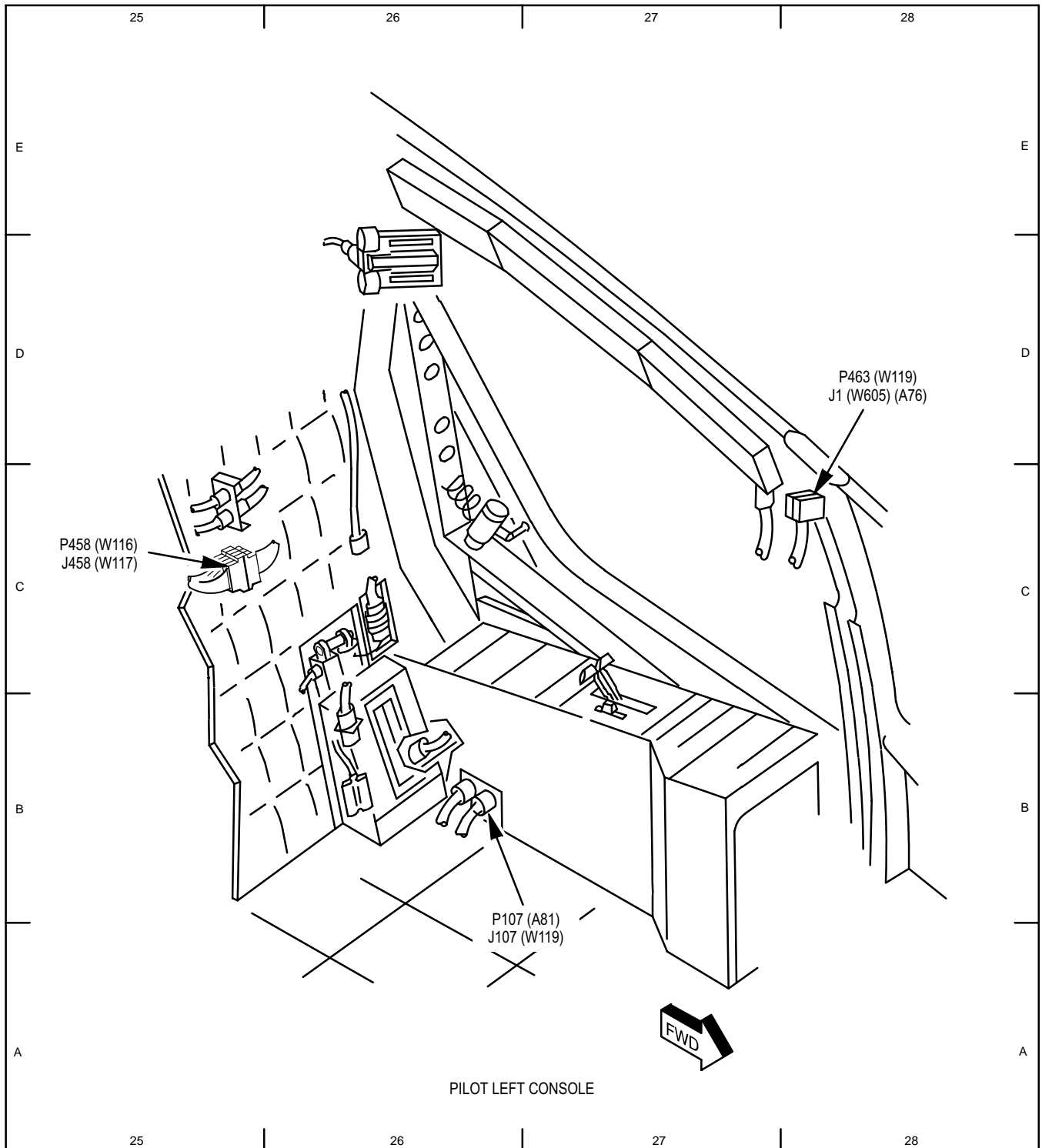

M71-306

Table 16-2. Electrical Component Location and Configuration (ECLC) Index Listing (cont)

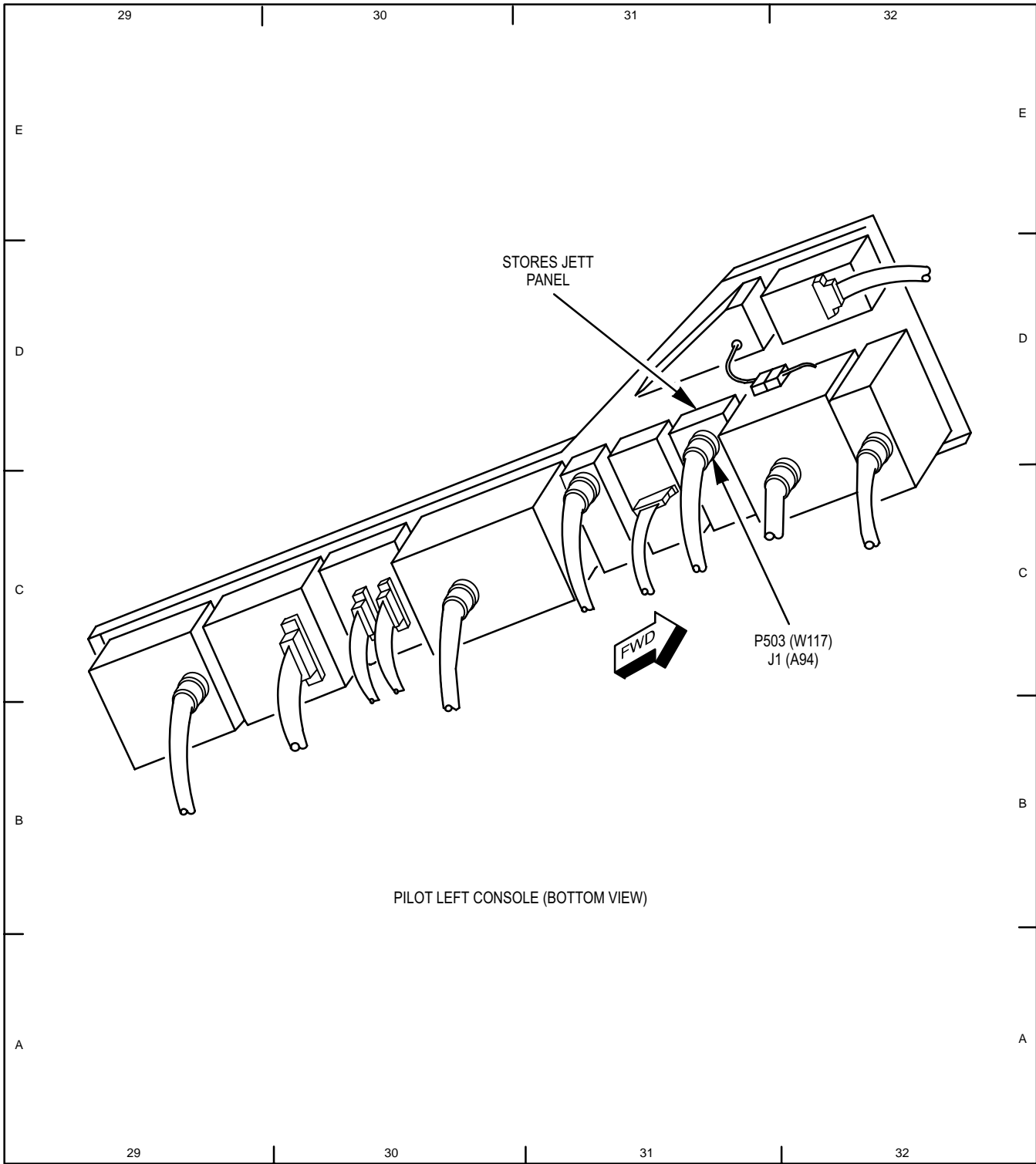

M71-307

16-9. ELECTRICAL COMPONENT LOCATION AND CONFIGURATION (ECLC) INDEX (cont)

16-9

Table 16-2. Electrical Component Location and Configuration (ECLC) Index Listing (cont)

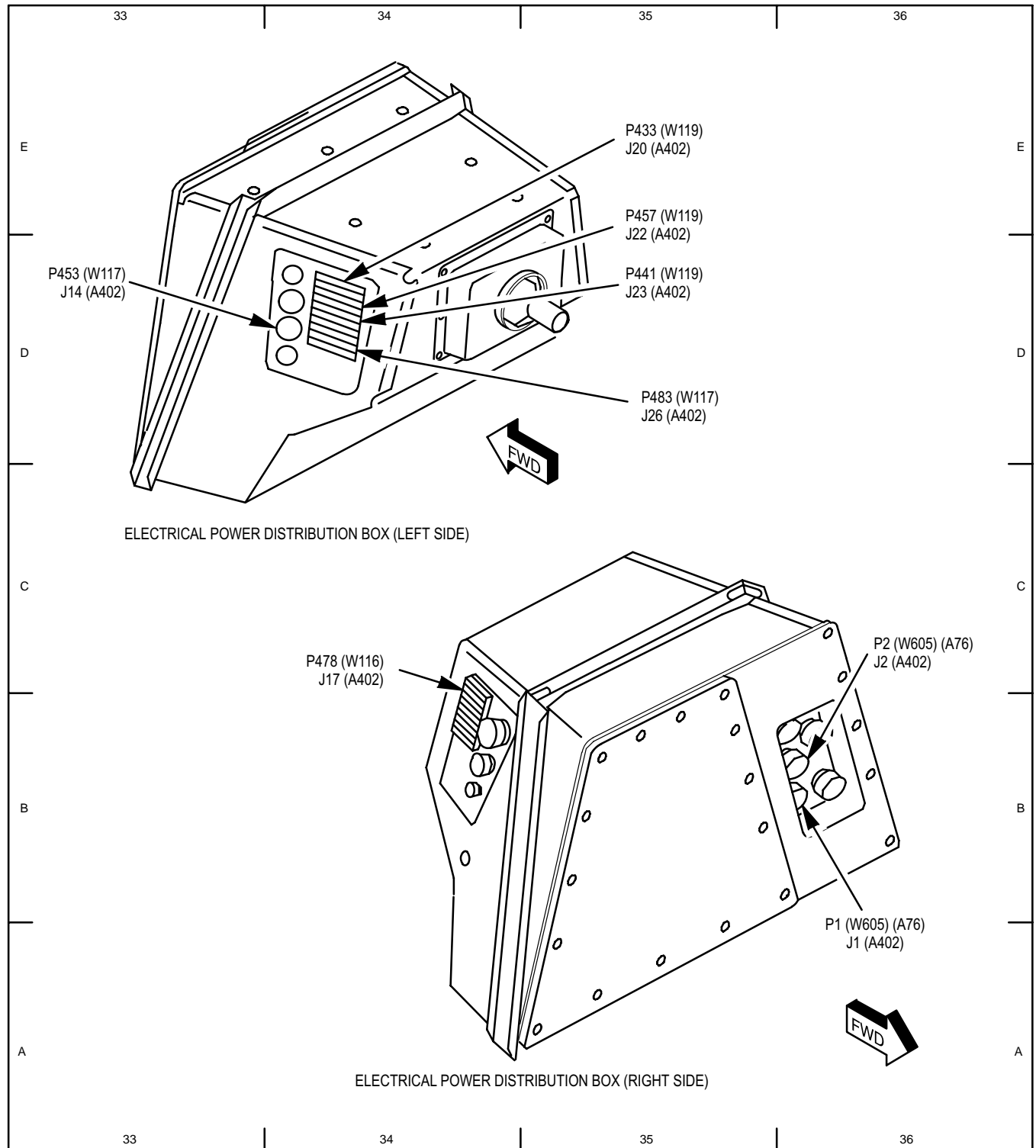

M71-308

Table 16-2. Electrical Component Location and Configuration (ECLC) Index Listing (cont)

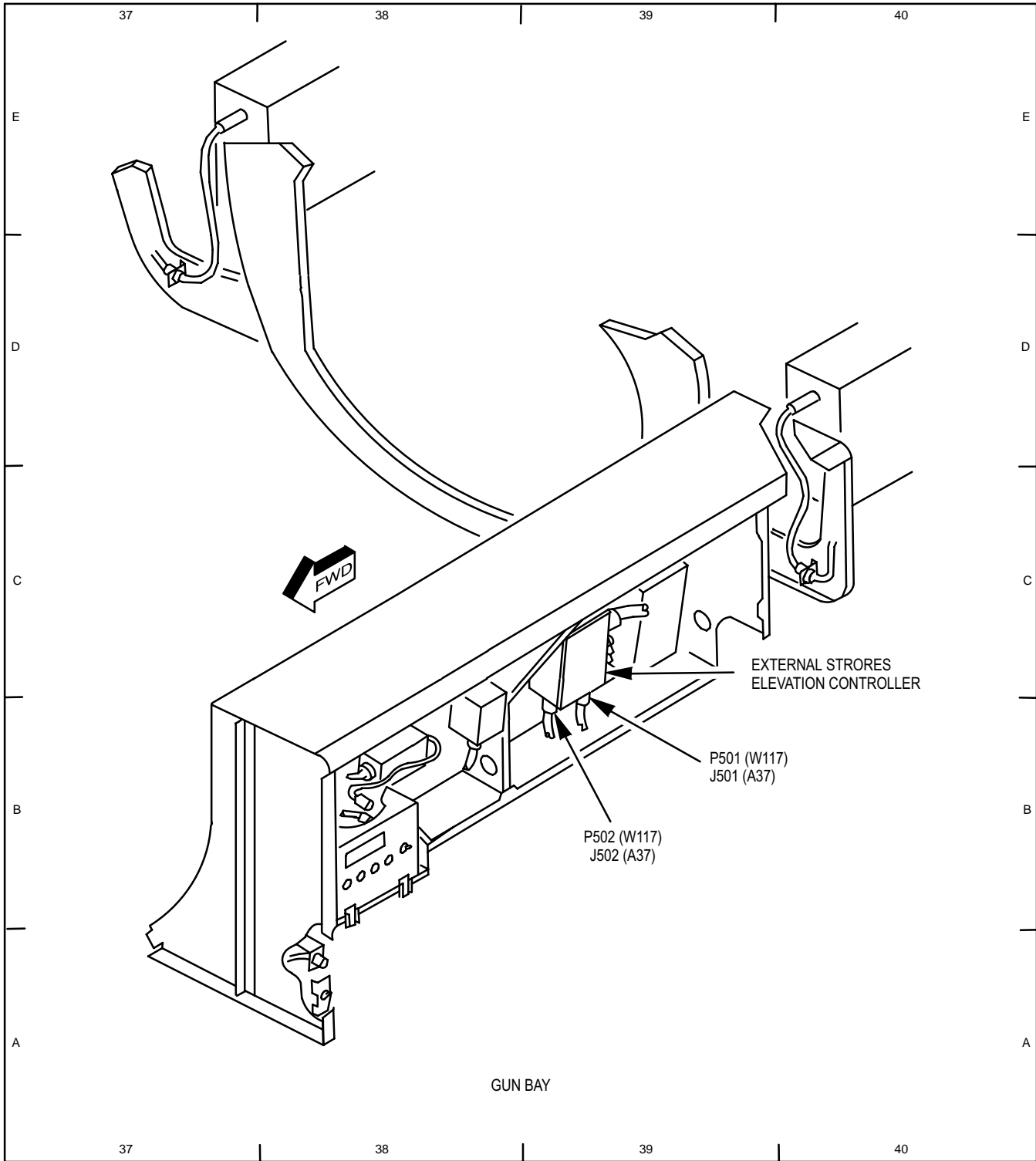

M71-260A

16-9. ELECTRICAL COMPONENT LOCATION AND CONFIGURATION (ECLC) INDEX (cont)

16-9

Table 16-2. Electrical Component Location and Configuration (ECLC) Index Listing (cont)

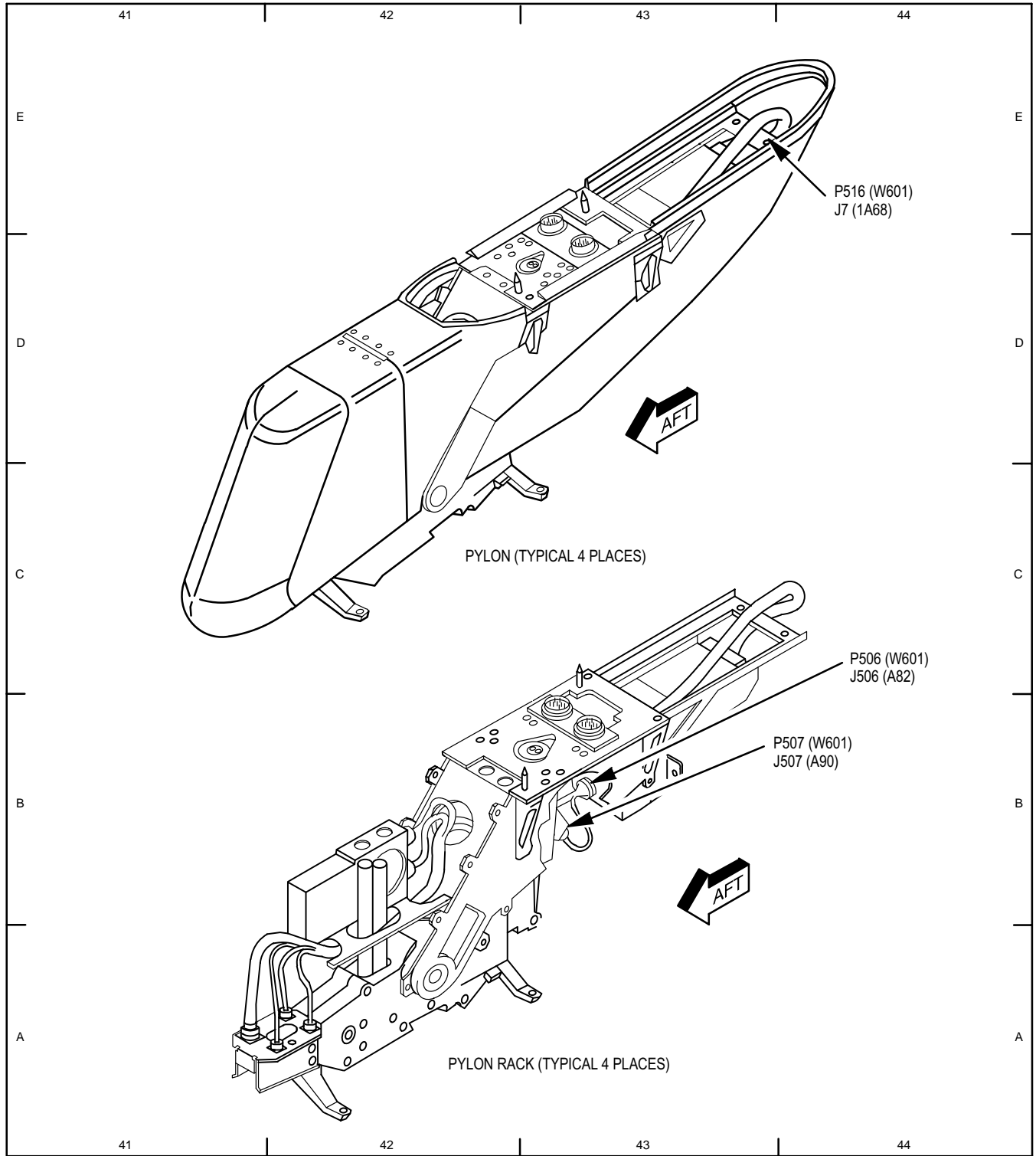

M71-270A

Table 16-2. Electrical Component Location and Configuration (ECLC) Index Listing (cont)

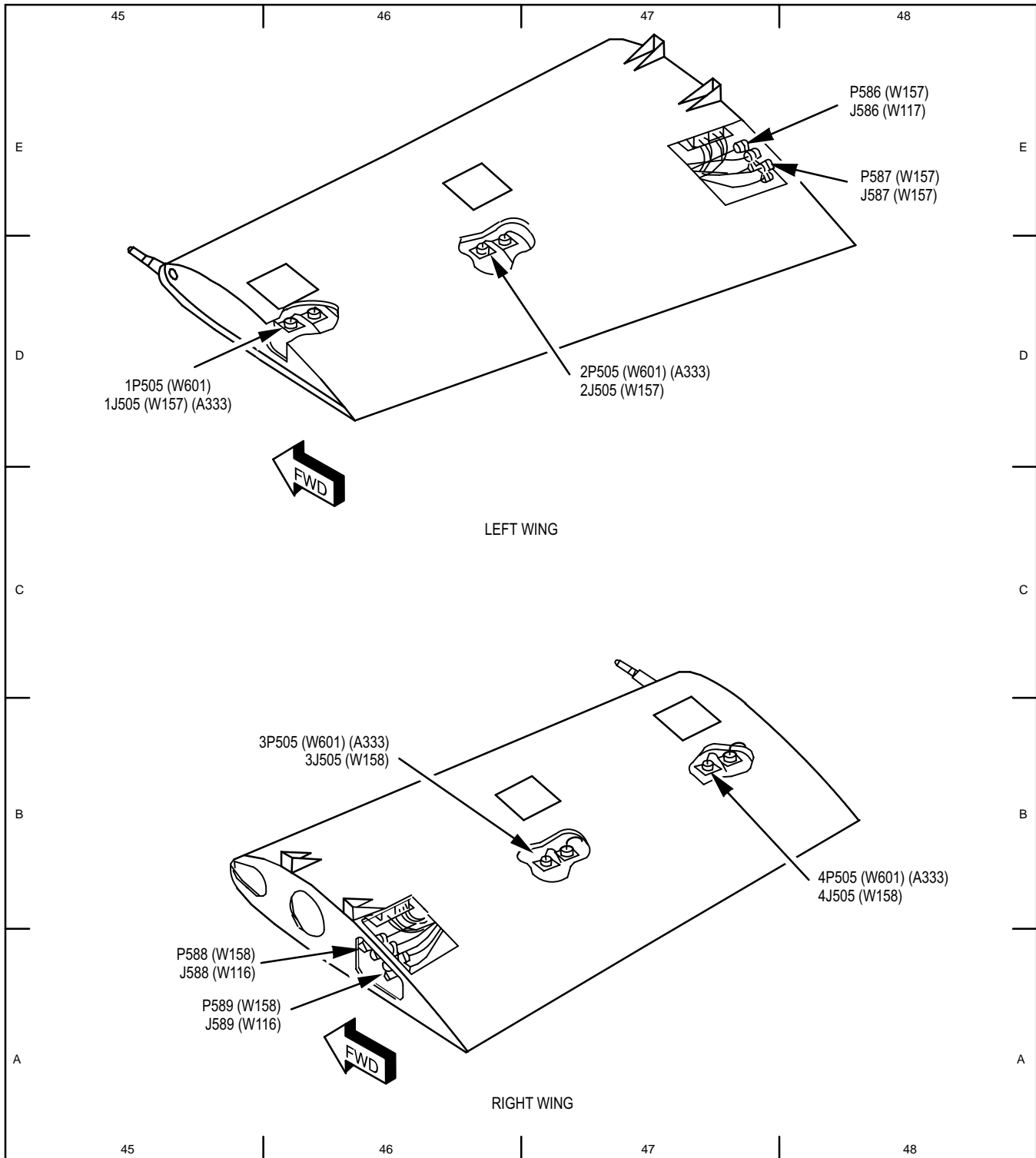

M71-309



16-10. EXTERNAL STORES - POWER UP

16-10

**Tools:**

<u>Nomenclature</u>	<u>Part Number</u>
Tool Kit, Aircraft Mechanic's	SC518099CLA01

**Personnel Required:**

67R Attack Helicopter Repairer

**References:**

TM 1-1520-238-23

**Equipment Conditions:**

<u>Ref</u>	<u>Condition</u>
TM 1-1520-238-23	Helicopter safed External power application - Electrical

**NOTE**

Refer to pilot station (fig. 16-8) for cockpit configuration and equipment.

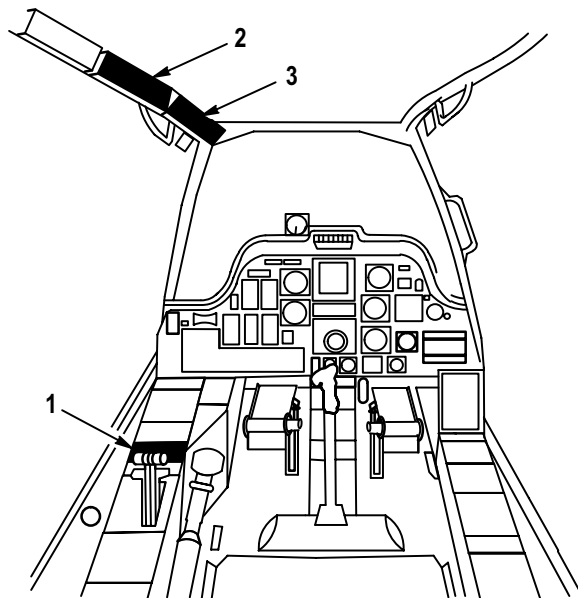

- 1. PILOT ELEC PWR PANEL
- 2. PILOT CENTER CIRCUIT BREAKER PANEL
- 3. PILOT FORWARD CIRCUIT BREAKER PANEL

M71-191

Figure 16-8. Pilot Station

1. On pilot **ELEC PWR** panel (fig. 16-9), set **BATT/EXT PWR** switch to **EXT PWR**.

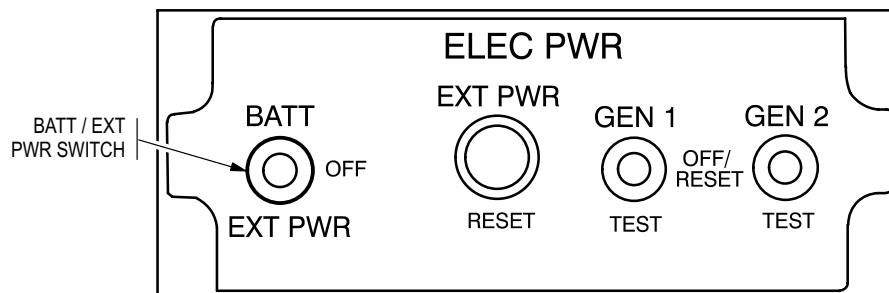

M71-192

Figure 16-9. Pilot ELEC PWR Panel

16-10. EXTERNAL STORES - POWER UP (cont)

16-10

2. On pilot circuit breaker panels (fig. 16-10), close the following circuit breakers:

Circuit Breaker Panel	<u>Circuit Breaker</u>	Circuit Breaker Panel	<u>Circuit Breaker</u>
Forward	<b>MISSION EL AC</b>	Forward	<b>MISSION JETT</b>
Forward	<b>MISSION EL DC</b>	Center	<b>JETT</b>
Forward	<b>MISSION ARM CONTR</b>		

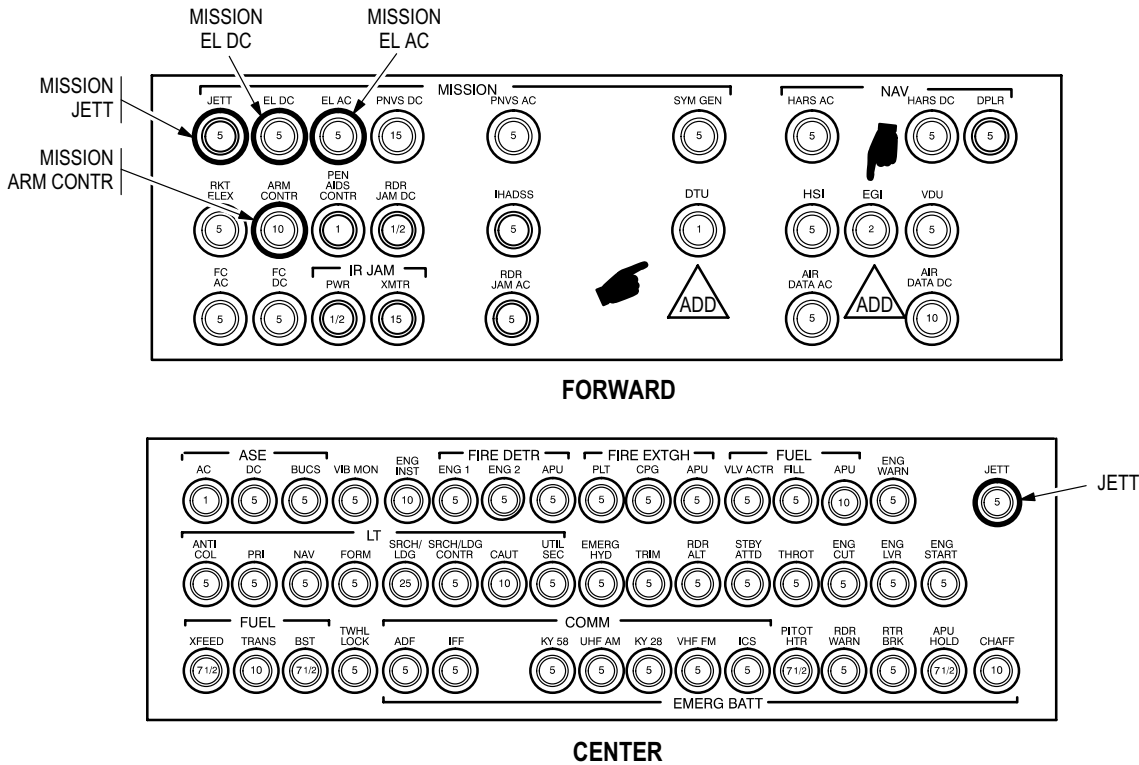

M71-193B

Figure 16-10. Pilot Circuit Breaker Panels

END OF TASK

**16-11. EXTERNAL STORES - POWER DOWN**

**16-11**

**Tools:**

<u>Nomenclature</u>	<u>Part Number</u>
Tool Kit, Aircraft Mechanic's	SC518099CLA01

**References:**

TM 1-1520-238-23

**Equipment Conditions:**

<u>Ref</u>	<u>Condition</u>
Paragraph 16-10	EXTERNAL STORES - POWER UP completed

**Personnel Required:**

67R Attack Helicopter Repairer

**NOTE**

**Refer to pilot station (fig. 16-8) for cockpit configuration and equipment.**

1. On pilot circuit breaker panels (fig. 16-14), open the following circuit breakers:

<u>Circuit Breaker Panel</u>	<u>Circuit Breaker</u>	<u>Circuit Breaker Panel</u>	<u>Circuit Breaker</u>
Forward	<b>MISSION EL AC</b>	Forward	<b>MISSION JETT</b>
Forward	<b>MISSION EL DC</b>	Center	<b>JETT</b>
Forward	<b>MISSION ARM CONTR</b>		

2. On pilot **ELEC PWR** panel (fig. 16-9), set **BATT/EXT PWR** switch to **OFF**.
3. Remove external power - electrical (TM 1-1520-238-23).

END OF TASK

**16-12. EXTERNAL STORES ELEVATION CONTROL - MAINTENANCE OPERATIONAL CHECK**

**16-12**

**Tools:**

Nomenclature

Part Number

Tool Kit, Aircraft  
Mechanic's

SC518099CLA01

**Equipment Conditions:**

Ref

Condition

TM 55-1520-238-23

External power application  
- Electrical  
- Hydraulic (utility)  
Access provisions-  
L115 door open  
Pylon fairings removed  
EXTERNAL STORES -  
POWER UP completed

**Personnel Required:**

67R Attack Helicopter Repairer  
One person to assist

Paragraph 16-10

**References:**

TM 1-1520-238-23  
TM 9-1090-208-23-2

**NOTE**

- Refer to pilot station (fig. 16-8) for cockpit configuration and equipment.
- If referenced out of one paragraph or volume into another for additional troubleshooting, upon completion of the task, return to the maintenance operational check for the original paragraph or volume.

1. Perform the maintenance operational check as follows:

Task	Result
<p>a. On pilot forward circuit breaker panel (fig. 16-10), check that <b>MISSION ARM CONTR</b>, <b>MISSION EL AC</b>, and <b>MISSION EL DC</b> circuit breakers are closed.</p>	<p>If <b>MISSION ARM CONTR</b> circuit breaker does not stay closed, go to paragraph 16-16.</p> <p>If <b>MISSION EL AC</b> does not stay closed, go to paragraph 16-14.</p> <p>If <b>MISSION EL DC</b> does not stay closed, go to paragraph 16-15.</p> <p>If <b>MISSION ARM CONTR</b> circuit breaker does not stay closed, go to paragraph 16-16.</p>

**16-12. EXTERNAL STORES ELEVATION CONTROL - MAINTENANCE OPERATIONAL CHECK (cont)**

**16-12**

Task	Result
<p>b. In left ammunition bay, set <b>PYLON ACTG SW (S128)</b> (fig. 16-11) to <b>UP</b> and then to <b>DOWN</b>. Check that all pylons move up and down.</p>	<p>If 2 or more pylons do not move, refer to TM 9-1090-208-23-2 to troubleshoot external stores control system.</p> <p>If left inboard pylon does not move, go to paragraph 16-17.</p> <p>If left outboard pylon does not move, go to paragraph 16-18.</p> <p>If right inboard pylon does not move, go to paragraph 16-19.</p> <p>If right outboard pylon does not move, go to paragraph 16-20.</p>

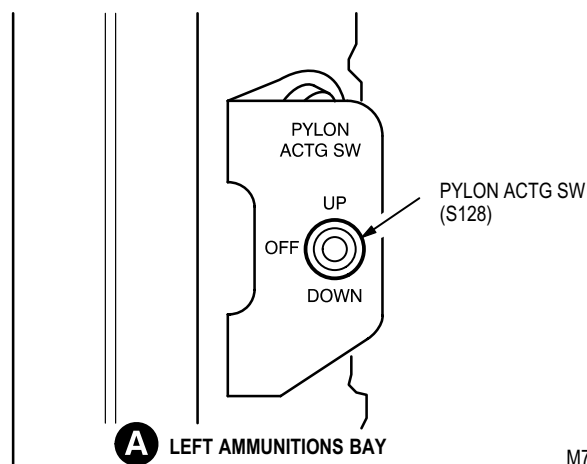
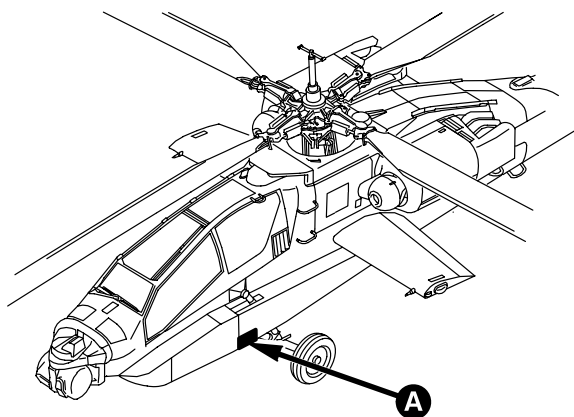

M71-195

**Figure 16-11. PYLON ACTG SW**

2. Perform EXTERNAL STORES - POWER DOWN (para 16-11).
3. Remove external power - electrical and hydraulic (TM 1-1520-238-23).
4. Disconnect maintenance headset (TM 1-1520-238-T-4).

END OF TASK

16-13. EXTERNAL STORES ELEVATION CONTROL - WIRING INTERCONNECT DIAGRAM

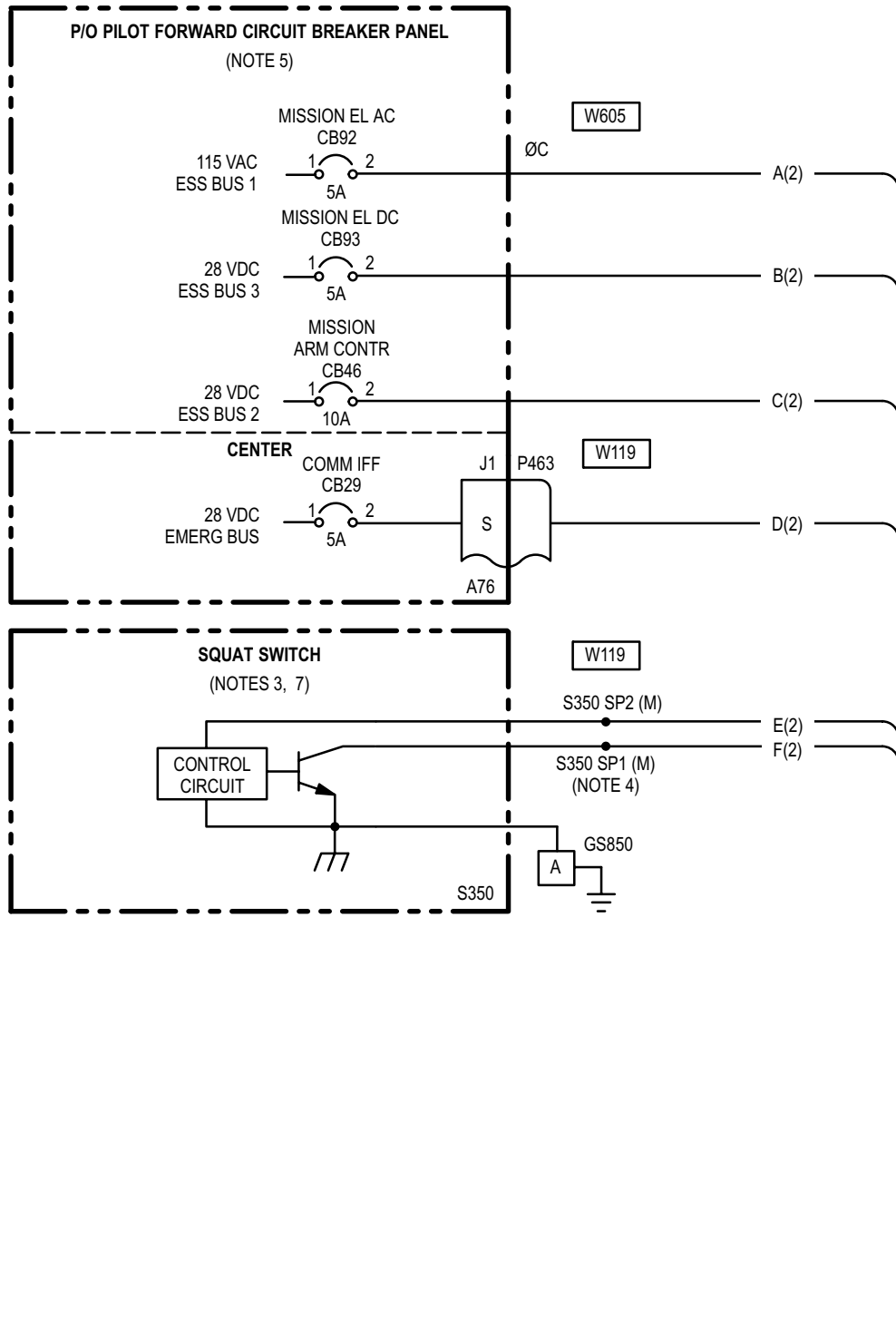

1

16-13. EXTERNAL STORES ELEVATION CONTROL - WIRING INTERCONNECT DIAGRAM (cont)

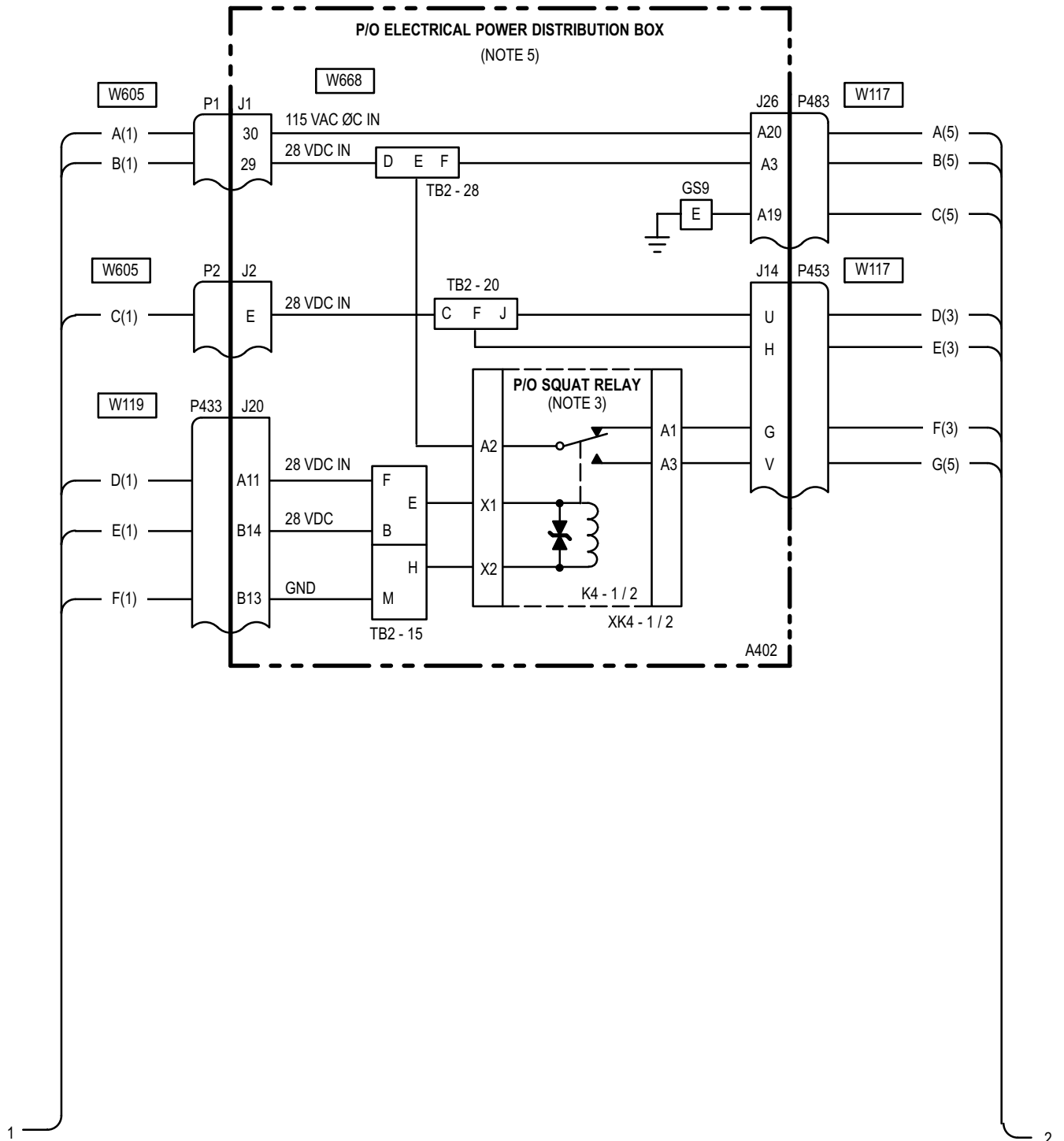

16-13. EXTERNAL STORES ELEVATION CONTROL - WIRING INTERCONNECT  
 DIAGRAM (cont)

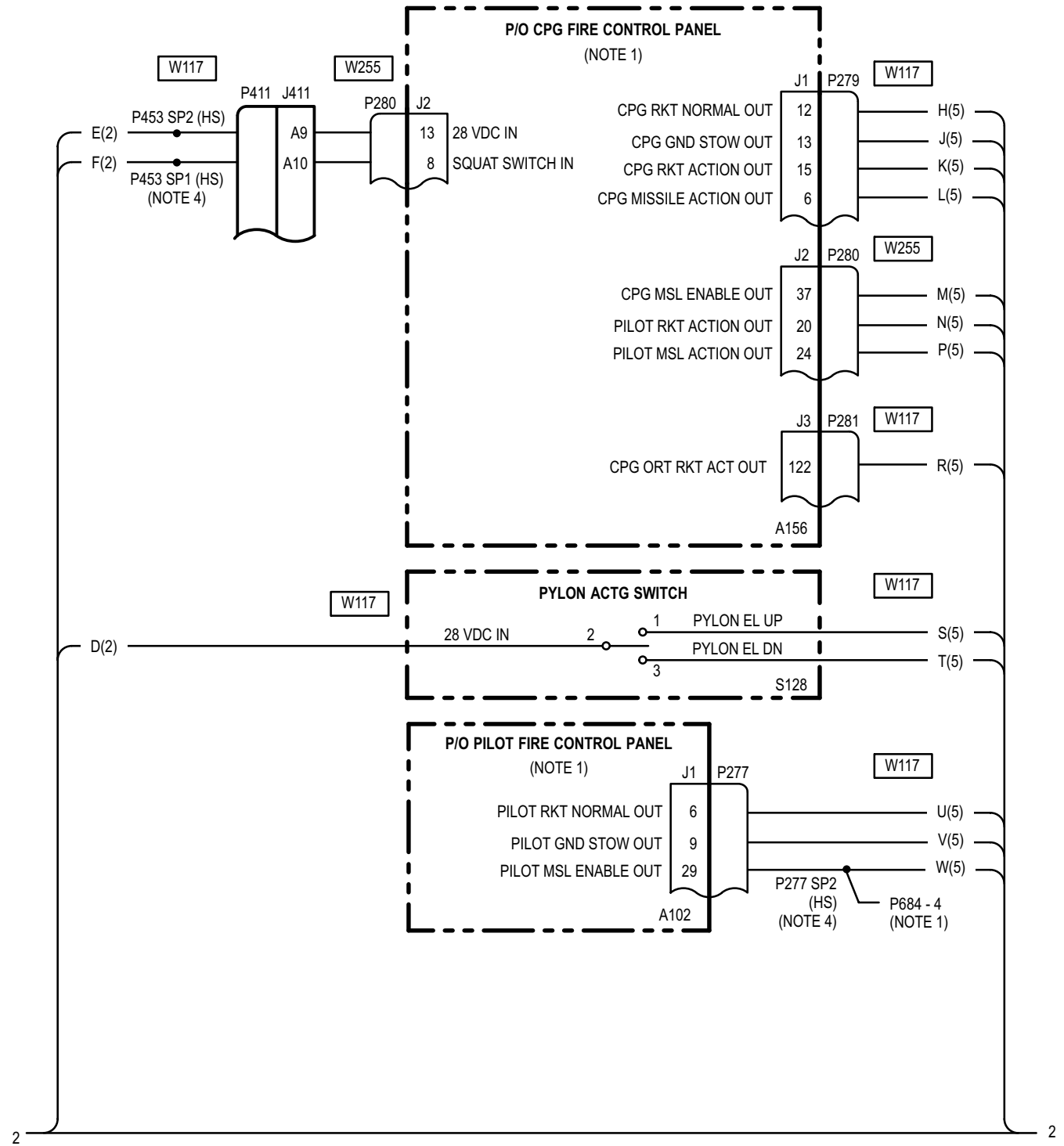



16-13. EXTERNAL STORES ELEVATION CONTROL - WIRING INTERCONNECT DIAGRAM (cont)

16-13

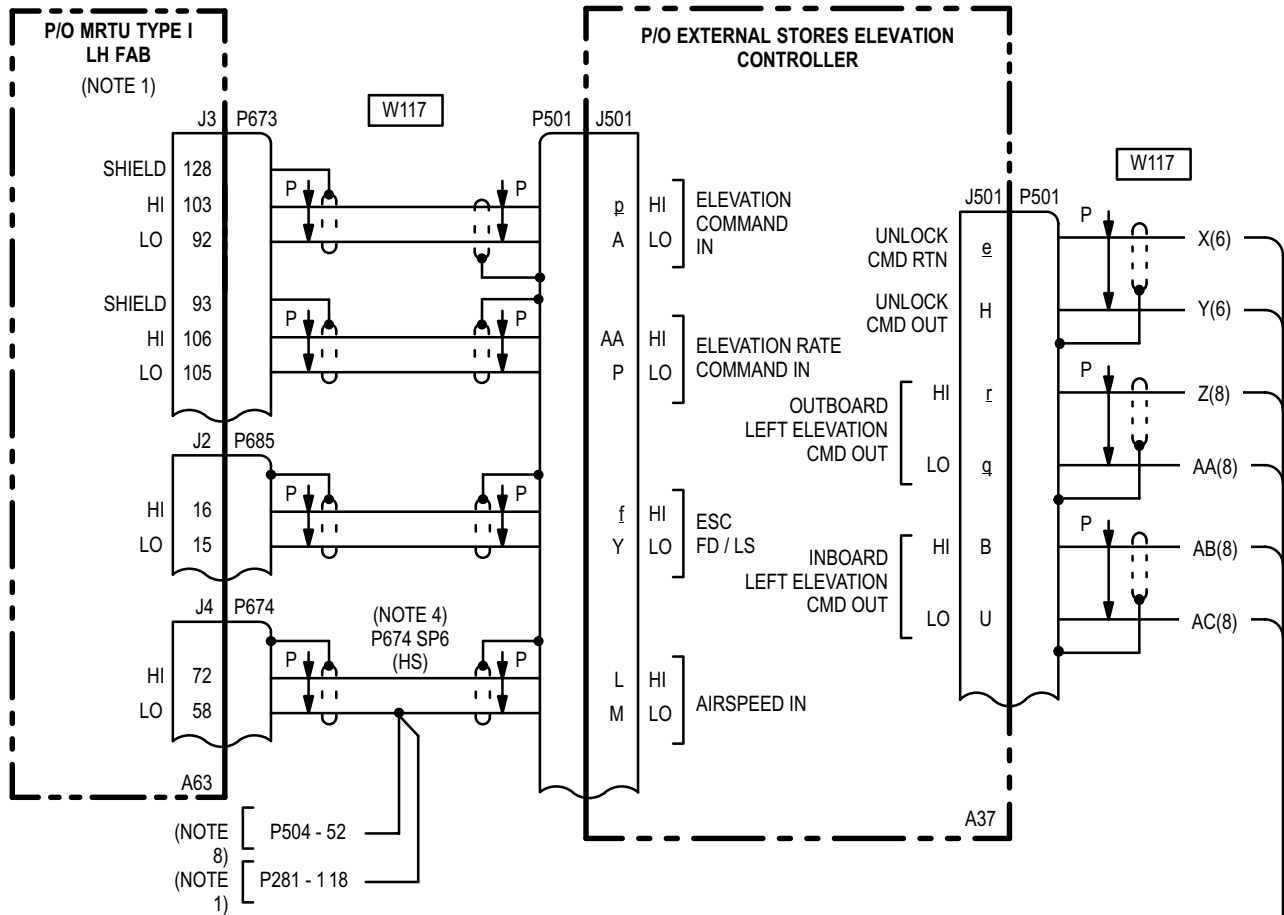

2

2

16-13. EXTERNAL STORES ELEVATION CONTROL - WIRING INTERCONNECT DIAGRAM (cont)

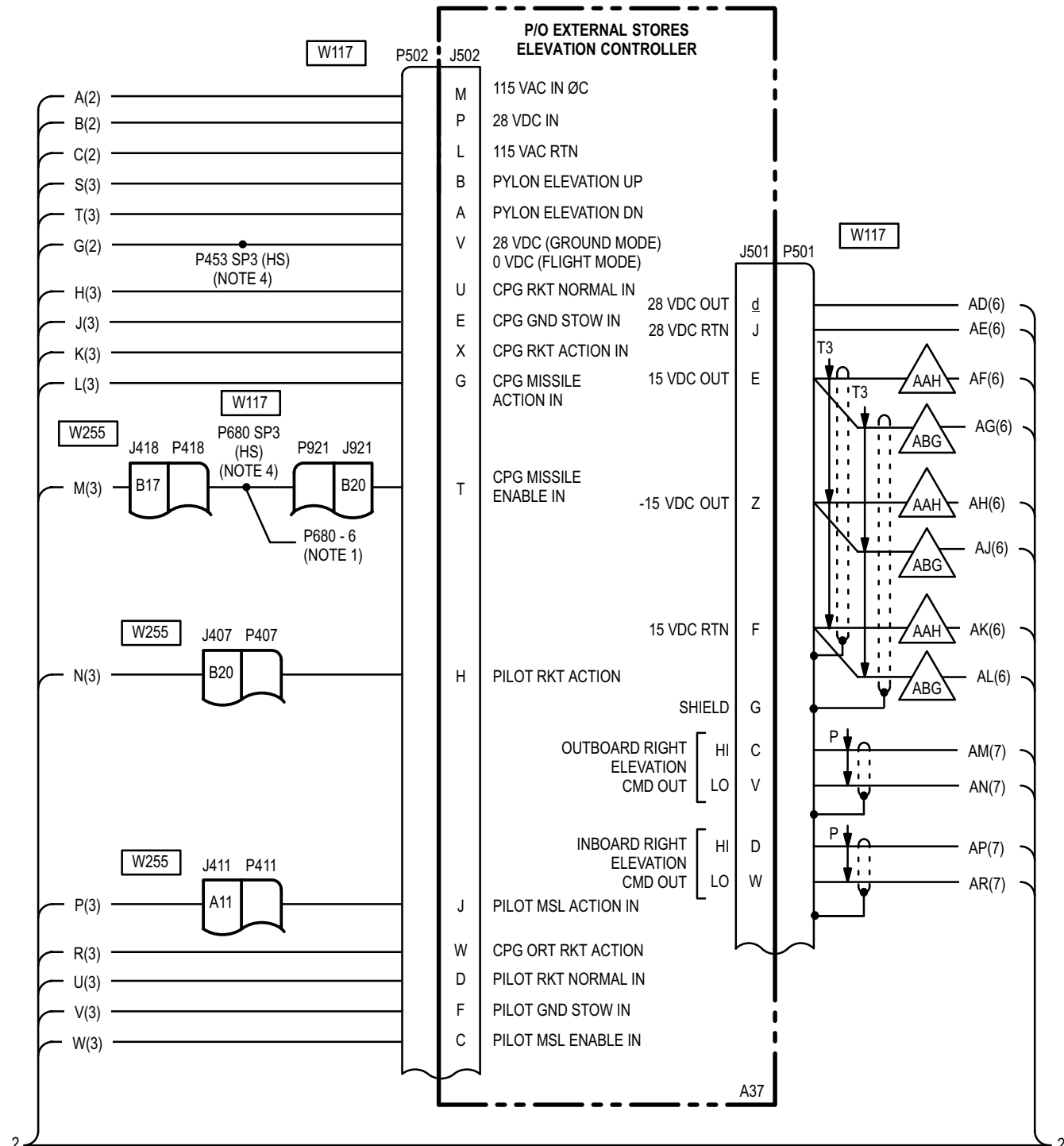

16-13. EXTERNAL STORES ELEVATION CONTROL - WIRING INTERCONNECT DIAGRAM (cont)

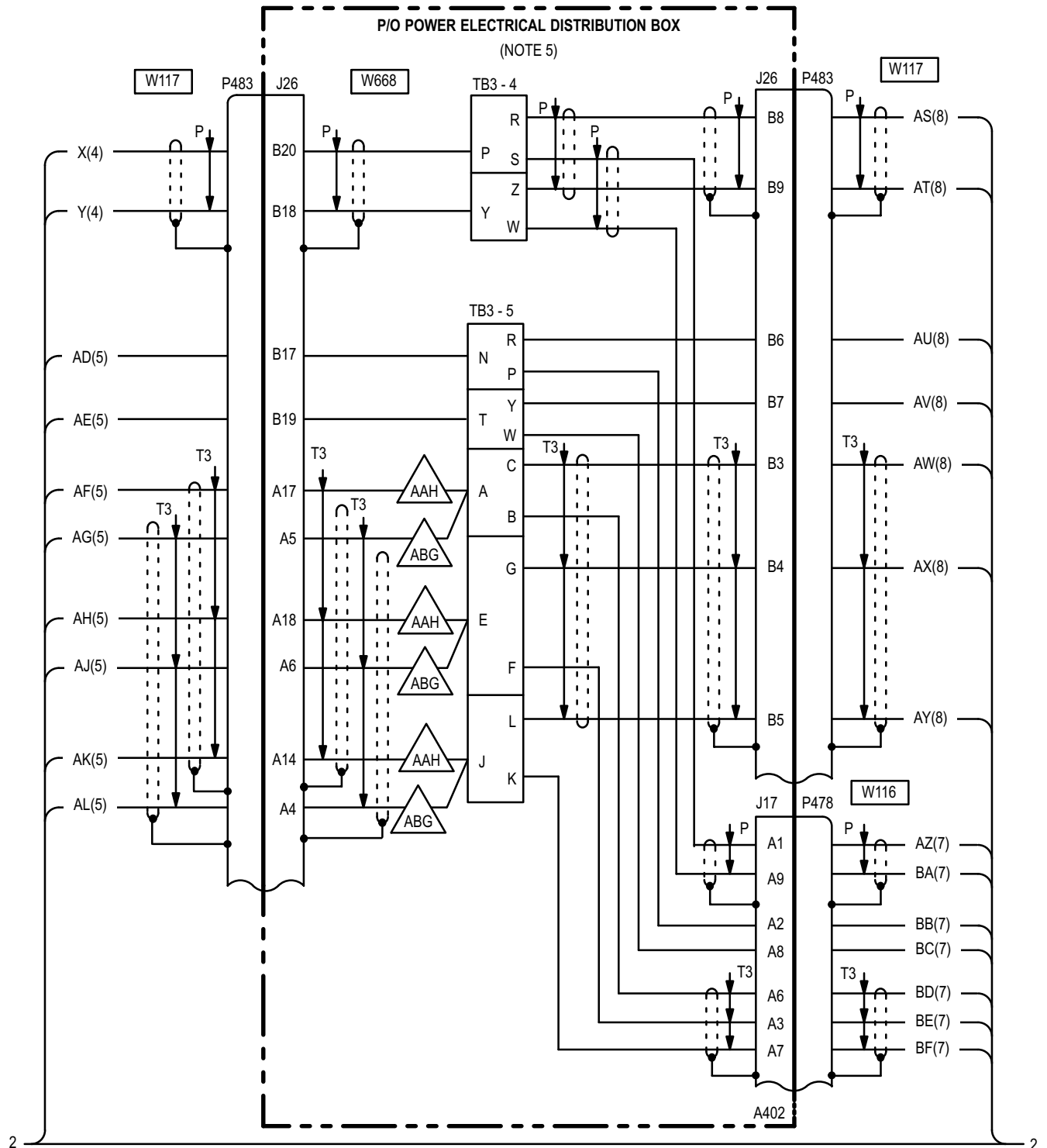

16-13. EXTERNAL STORES ELEVATION CONTROL - WIRING INTERCONNECT  
 DIAGRAM (cont)

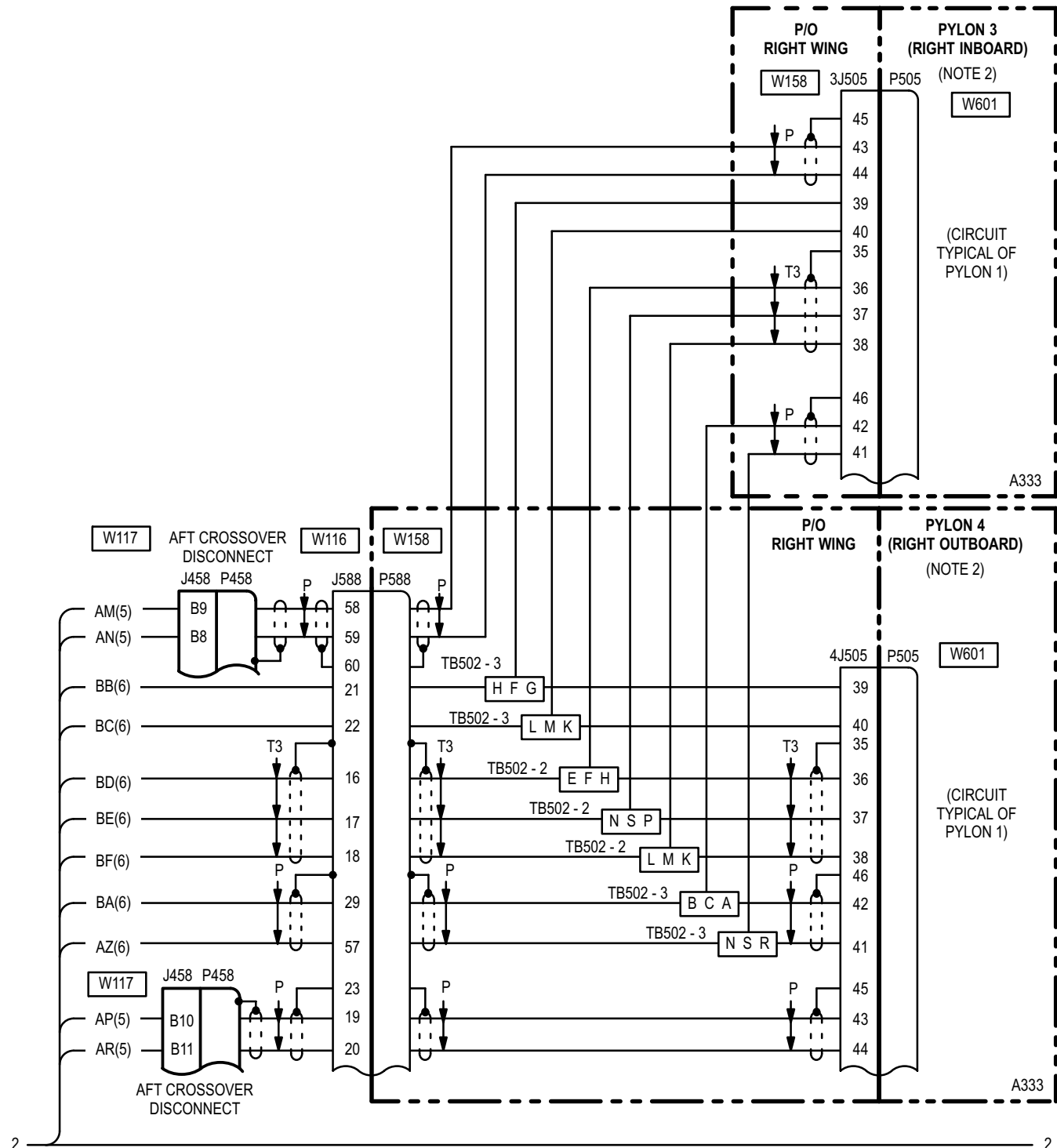

16-13. EXTERNAL STORES ELEVATION CONTROL - WIRING INTERCONNECT  
DIAGRAM (cont)

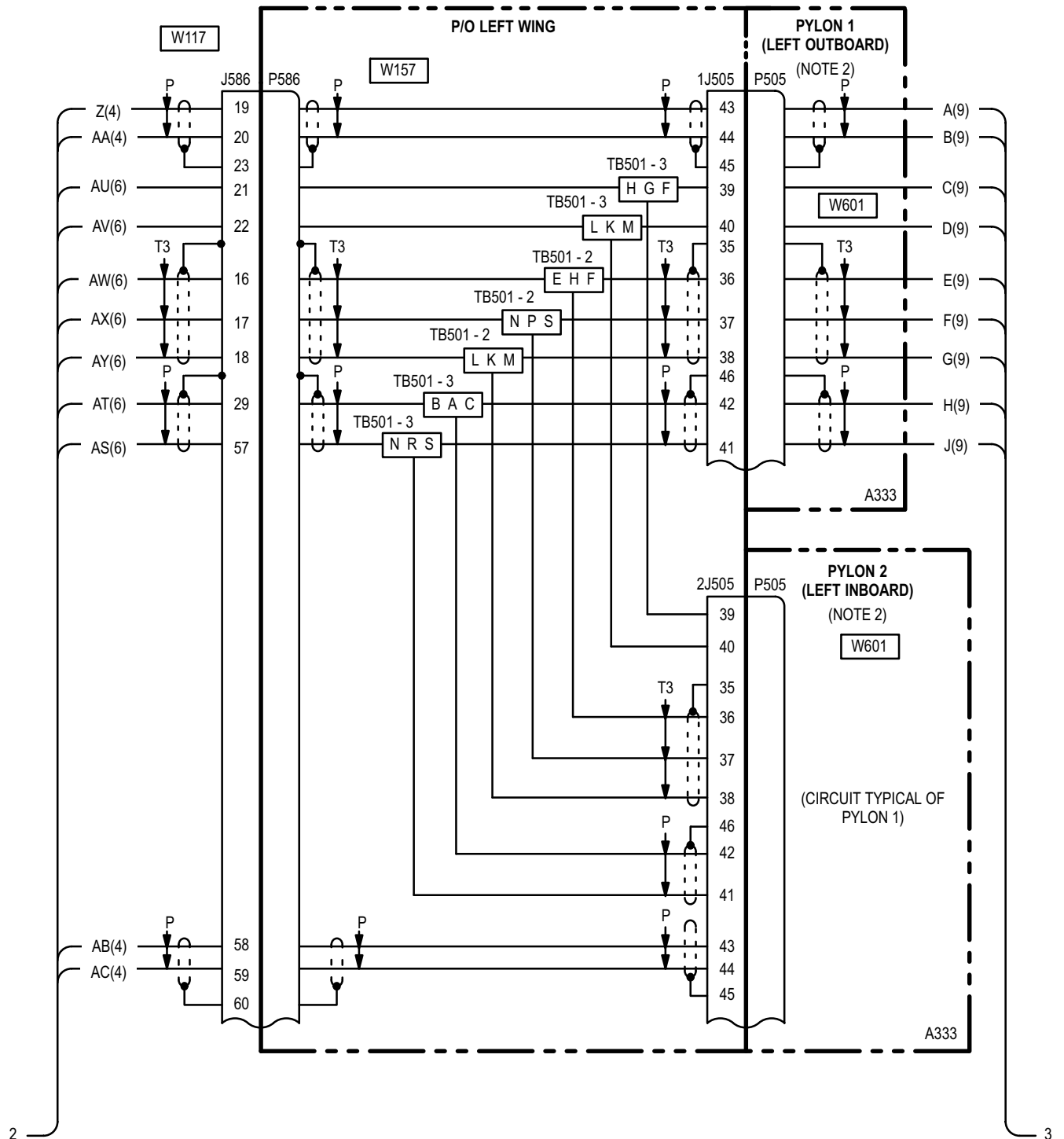

16-13. EXTERNAL STORES ELEVATION CONTROL - WIRING INTERCONNECT DIAGRAM (cont)

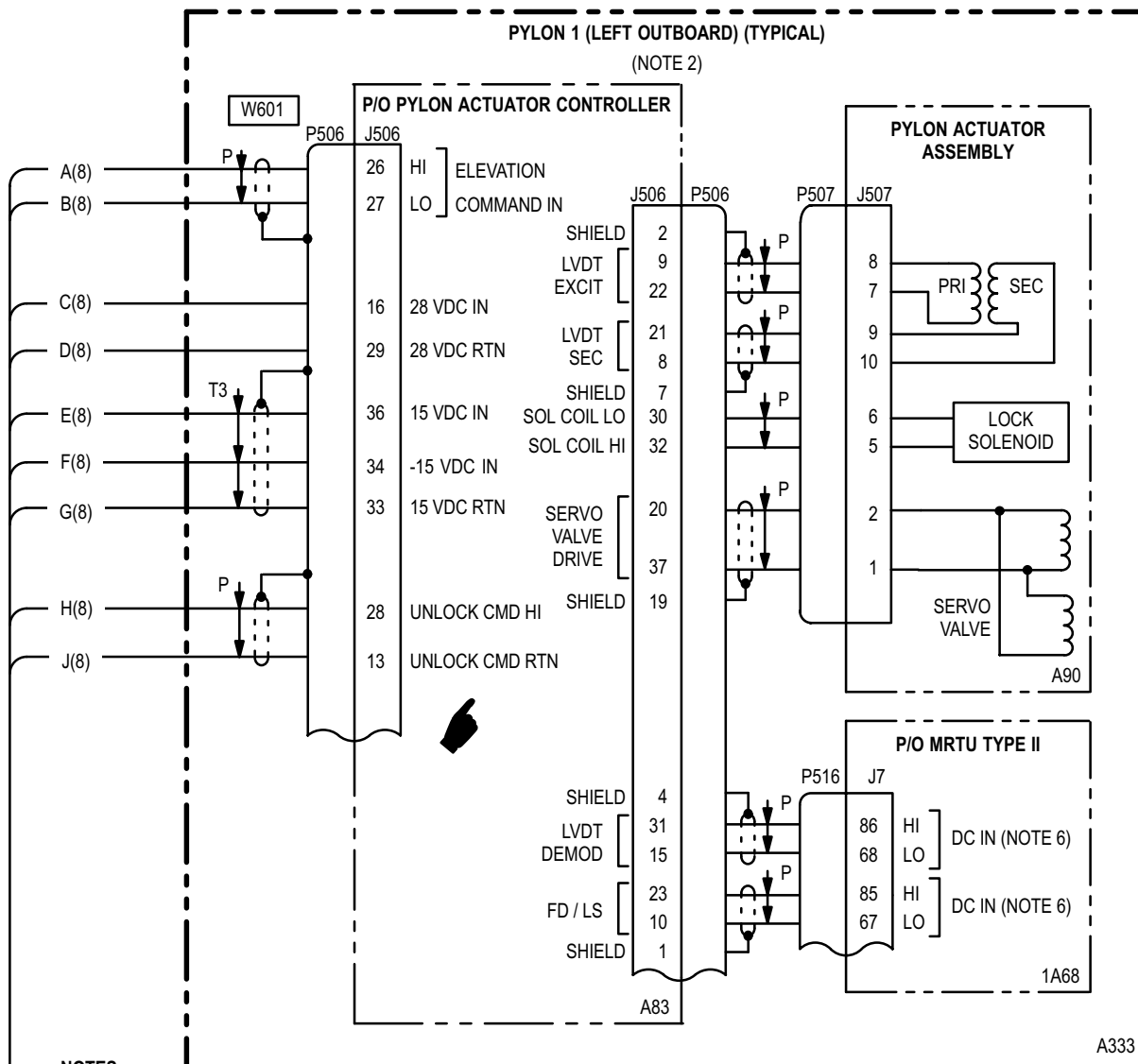

NOTES:

HIGHWAY USE: THE ALPHA CHARACTER IDENTIFIES A SPECIFIC LINE, AND THE NUMBER IN PARENTHESIS IDENTIFIES THE SHEET NUMBER WHERE THE SIGNAL TERMINATES.

1. FIRE CONTROL SYSTEM (TM 9-1230-476-20-2).
2. EXTERNAL STORES.
3. AIRBORNE - CONTACTS A2 AND A3 CLOSED.  
ON GROUND - CONTACTS A2 AND A1 CLOSED.  
WHEN HELICOPTER ON GROUND, SQUAT SWITCH REMOVES GROUND FROM THIS LINE.  
(GROUND PROVIDED WHEN SQUAT SWITCH FIXTURE INSTALLED.)
4. HS DESIGNATES A HARD SPLICE WHICH CANNOT BE DISCONNECTED.  
M DESIGNATES A SOFT SPLICE WHICH MAY BE DISCONNECTED FOR A WIRING CHECK.
5. ELECTRICAL SYSTEM (TM 1-1520-238-T-6).
6. SERIAL DIGITAL DATA.
7. IFF - AVIONICS CONFIGURATION (TM 11-1520-238-23-2).
8. AERIAL ROCKET CONTROL SYSTEM - ARMAMENT SUBSYSTEM (TM 9-1090-208-23-2).

3

**16-14. MISSION EL AC CIRCUIT BREAKER (CB92) - DOES NOT STAY CLOSED****16-14****Tools:**

<u>Nomenclature</u>	<u>Part Number</u>
Tool Kit, Electrical Repairer's	SC518099CLA06
Multimeter, Digital	AN/PSM-45

**Personnel Required:**

68X Armament/Electrical Systems Repairer

**References:**

TM 1-1520-238-T-6

TM 1-1520-238-23

<b>WARNING</b>
----------------

**Turn off power before detaching or attaching wires and connectors. High current 28 VDC or 115 VAC is present. Failure to do so could result in death or serious injury.**

- Open **MISSION EL AC** circuit breaker (CB92).  
Check for short between P1-30 and ground.  
**Does short exist?**

YES	Refer to TM 1-1520-238-T-6 to troubleshoot circuit protection system (ac essential bus 1 - pilot station).
NO	Go to step 2.
- Detach P502. Check for short between (A402)J1-30 and ground.  
**Does short exist?**

YES	Repair shorted wire between (A402): J1-30 and J26-A10. Go to paragraph 16-12.
NO	Replace external stores elevation controller (TM 1-1520-238-23).

END OF TASK

**16-15. MISSION EL DC CIRCUIT BREAKER (CB93) - DOES NOT STAY CLOSED**

**16-15**

**Tools:**

<u>Nomenclature</u>	<u>Part Number</u>
Tool Kit, Electrical Repairer's	SC518099CLA06
Multimeter, Digital	AN/PSM-45
Extractor, Relay	CTJ-RO6

**Personnel Required:**

68X Armament/Electrical Systems Repairer

**References:**

- TM 1-1520-238-T-6
- TM 1-1520-238-23
- TM 9-1230-476-20-1

**WARNING**

**Turn off power before detaching or attaching wires and connectors. High current 28 VDC or 115 VAC is present. Failure to do so could result in death or serious injury.**

1. Open **MISSION EL DC** circuit breaker (CB93). Check for short between P1-29 and ground.  
**Does short exist?**
  - YES Refer to TM 1-1520-238-T-6 to troubleshoot circuit protection system (dc essential bus 2 - pilot station).
  - NO Go to step 2.
  
2. Detach P453 and P483. Check for short between (A402)J1-29 and ground.  
**Does short exist?**
  - YES Go to step 6.
  - NO Go to step 3.
  
3. Check for short between P453-G and ground.  
**Does short exist?**
  - YES Go to step 4.
  - NO Go to step 5.

4. Detach P280. Check for short between P453-G and ground.

**Does short exist?**

- YES Repair shorted wire between: J411-A10 and P453-G, P411-A10 and P280-8. Go to paragraph 16-12.
- NO Replace CPG **FIRE CONTROL** panel (TM 9-1230-476-20-1).

5. Detach P502. Check for short between P483-A3 and ground.

**Does short exist?**

- YES Repair shorted wire between P483-A3 and P502-P. Go to paragraph 16-12.
- NO Replace external stores elevation controller (TM 1-1520-238-23).

6. With squat relay (A402)K4-1/2 removed, check for short between relay case and (A402)K4-1/2-A2.

**Does short exist?**

- YES Replace relay (A402)K4-1/2 (TM 1-1520-238-23).
- NO Repair shorted wire between (A402): J1-29 and TB2-28-D, J14-G and XK4-1/2-A1, J26-A3 and TB2-28-F, TB2-28-E and XK4-1/2-A2. Go to paragraph 16-12.

END OF TASK



**16-16. MISSION ARM CONTR CIRCUIT BREAKER (CB46) - DOES NOT STAY CLOSED**

**16-16**

**Tools:**

<u>Nomenclature</u>	<u>Part Number</u>
Tool Kit, Electrical Repairer's	SC518099CLA06
Multimeter, Digital	AN/PSM-45

**Personnel Required:**

68X Armament/Electrical Systems Repairer

**References:**

- TM 1-1520-238-T-6
- TM 1-1520-238-23
- TM 9-1230-476-20-1



**Turn off power before detaching or attaching wires and connectors. High current 28 VDC or 115 VAC is present. Failure to do so could result in death or serious injury.**

1. Open **MISSION ARM CONTR** circuit breaker (CB46). Check for short between P2-E and ground.

**Does short exist?**

YES	Refer to TM 1-1520-238-T-6 to troubleshoot circuit protection system (dc essential bus 2 - pilot station).
NO	Go to step 2.

2. Detach wires from (A402):  
TB2-20-C,  
TB2-20-F,  
TB2-20-J.

Check for short between (A402):  
J2-E and ground,  
J14-H and ground,  
J14-U and ground.

**Does short exist?**

YES	Repair shorted wire between (A402): J2-E and TB2-20-C, J14-H and TB2-20-F, J14-U and TB2-20-J. Go to paragraph 16-12.
NO	Go to step 3.

3. Check for short between P453-H and ground.
- Does short exist?**

YES	Go to step 4.
NO	Go to step 5.

4. Remove P280. Check for short between P453-H and ground.

**Does short exist?**

YES	Repair shorted wire between P453-H and P280-13. Go to paragraph 16-12.
NO	Replace CPG <b>FIRE CONTROL</b> panel (TM 9-1230-476-20-1).

5. Detach wire from S128-2. Check for short between P453-U and ground.

**Does short exist?**

YES	Repair shorted wire between P453-U and S128-2. Go to paragraph 16-12.
NO	Go to step 6.

---

**16-16. MISSION ARM CONTR CIRCUIT BREAKER (CB46) - DOES NOT STAY CLOSED (cont)**

---

**16-16**

6. Detach wires from S128-1 and S128-3. Check for short between:  
P502-B and ground,  
P502-A and ground.

**Does short exist?**

- |     |  |
|-----|--|
| YES | Repair shorted wire between:<br>P502-B and S128-1,<br>P502-A and S128-3.<br>Go to paragraph 16-12. |
| NO  | Replace external stores<br>elevation controller<br>(TM 1-1520-238-23).                             |

END OF TASK

16-17. LEFT INBOARD PYLON - DOES NOT MOVE

16-17

**Tools:**

<u>Nomenclature</u>	<u>Part Number</u>
Tool Kit, Electrical Repairer's	SC518099CLA06
Multimeter, Digital	AN/PSM-45

**Personnel Required:**

68X Armament/Electrical Systems Repairer

**References:**

TM 1-1520-238-23

**Equipment Conditions:**

<u>Ref</u>	<u>Condition</u>
TM 1-1520-238-23	Pylon fairing removed



**Turn off power before detaching or attaching wires and connectors. High current 28 VDC or 115 VAC is present. Failure to do so could result in death or serious injury.**

- Detach (2)P507 and (2)P506. Check for open between:  
(2)P506-21 and (2)P507-9,  
(2)P506-8 and (2)P507-10,  
(2)P506-30 and (2)P507-6,  
(2)P506-32 and (2)P507-5.  
**Does open exist?**  

YES	Repair open wire. Go to paragraph 16-12.
NO	Go to step 2.
- Check for open between:  
(2)J507-5 and (2)J507-6,  
(2)J507-9 and (2)J507-10.  
**Does open exist?**  

YES	Replace pylon actuator 2 (TM 1-1520-238-23).
NO	Go to step 3.

- Check for short between:  
(2)J507-6 and case,  
(2)J507-9 and case.  
**Does open exist?**  

YES	Replace pylon actuator 2 (TM 1-1520-238-23).
NO	Go to step 4.
- Check for short between:  
(2)P506-8 and backshell,  
(2)P506-21 and backshell,  
(2)P506-30 and backshell,  
(2)P506-32 and backshell.  
**Does open exist?**  

YES	Repair shorted wire. Go to paragraph 16-12.
NO	Go to step 5.
- Check for open between:  
(2)J507-7 and (2)J507-8,  
(2)J507-1 and (2)J507-2.  
**Does open exist?**  

YES	Replace pylon actuator 2 (TM 1-1520-238-23).
NO	Go to step 6.
- Check for short between:  
(2)J507-8 and case,  
(2)J507-2 and case.  
**Does open exist?**  

YES	Replace pylon actuator 2 (TM 1-1520-238-23).
NO	Go to step 7.
- Detach TB501-2-S and (2)P506. Check for open between: (2)P506-34 and wire and TB501-2-S.  
**Does open exist?**  

YES	Repair open wire. Go to paragraph 16-12.
NO	Go to step 8.

---

16-17. LEFT INBOARD PYLON - DOES NOT MOVE (cont)

---

16-17

8. Check for short between:  
(2)P507-8 and backshell,  
(2)P507-7 and backshell,  
(2)P507-2 and backshell,  
(2)P507-1 and backshell.

**Does open exist?**

- |     |  |
|-----|--|
| YES | Repair shorted wire.<br>Go to paragraph 16-12.                 |
| NO  | Replace pylon actuator<br>controller 2<br>(TM 55-1520-238-23). |

END OF TASK

**16-18. LEFT OUTBOARD PYLON - DOES NOT MOVE**

**16-18**

**Tools:**

<u>Nomenclature</u>	<u>Part Number</u>
Tool Kit, Electrical Repairer's	SC518099CLA06
Multimeter, Digital	AN/PSM-45

**Personnel Required:**

68X Armament/Electrical Systems Repairer

**References:**

TM 1-1520-238-23

**Equipment Conditions:**

<u>Ref</u>	<u>Condition</u>
TM 1-1520-238-23	Pylon fairing removed



**Turn off power before detaching or attaching wires and connectors. High current 28 VDC or 115 VAC is present. Failure to do so could result in death or serious injury.**

1. Detach (1)P507 and (1)P506. Check for open between:  
 (1)P506-21 and (1)P507-9,  
 (1)P506-8 and (1)P507-10,  
 (1)P506-30 and (1)P507-6,  
 (1)P506-32 and (1)P507-5.  
**Does open exist?**  

YES	Repair open wire. Go to paragraph 16-12.
NO	Go to step 2.
  
2. Check for open between:  
 (1)J507-5 and (1)J507-6,  
 (1)J507-9 and (1)J507-10.  
**Does open exist?**  

YES	Replace pylon actuator 1 (TM 1-1520-238-23).
NO	Go to step 3.

3. Check for short between:  
 (1)J507-6 and case,  
 (1)J507-9 and case.  
**Does open exist?**  

YES	Replace pylon actuator 1 (TM 1-1520-238-23).
NO	Go to step 4.
  
4. Check for short between:  
 (1)P506-8 and backshell,  
 (1)P506-21 and backshell,  
 (1)P506-30 and backshell,  
 (1)P506-32 and backshell.  
**Does open exist?**  

YES	Repair shorted wire. Go to paragraph 16-12.
NO	Go to step 5.
  
5. Check for open between:  
 (1)J507-7 and (1)J507-8,  
 (1)J507-1 and (1)J507-2.  
**Does open exist?**  

YES	Replace pylon actuator 1 (TM 1-1520-238-23).
NO	Go to step 6.
  
6. Check for short between:  
 (1)J507-8 and case,  
 (1)J507-2 and case.  
**Does open exist?**  

YES	Replace pylon actuator 1 (TM 1-1520-238-23).
NO	Go to step 7.
  
7. Detach TB501-2-P and (1)P506. Check for open between (1)P506-34 and wire end TB501-2-P.  
**Does open exist?**  

YES	Repair open wire. Go to paragraph 16-12.
NO	Go to step 8.

---

**16-18. LEFT OUTBOARD PYLON - DOES NOT MOVE (cont)**

---

**16-18**

8. Check for short between:  
(1)P507-8 and backshell,  
(1)P507-7 and backshell,  
(1)P507-2 and backshell,  
(1)P507-1 and backshell.

**Does open exist?**

- |     |   |
|-----|---|
| YES | Repair shorted wire.<br>Go to paragraph 16-12.                |
| NO  | Replace pylon actuator<br>controller 1<br>(TM 1-1520-238-23). |

END OF TASK

**16-19. RIGHT INBOARD PYLON - DOES NOT MOVE**

**16-19**

**Tools:**

<u>Nomenclature</u>	<u>Part Number</u>
Tool Kit, Electrical Repairer's	SC518099CLA06
Multimeter, Digital	AN/PSM-45

**Personnel Required:**

68X Armament/Electrical Systems Repairer

**References:**

TM 1-1520-238-23

**Equipment Conditions:**

<u>Ref</u>	<u>Condition</u>
TM 1-1520-238-23	Pylon fairing removed

**WARNING**

**Turn off power before detaching or attaching wires and connectors. High current 28 VDC or 115 VAC is present. Failure to do so could result in death or serious injury.**

1. Detach (3)P507 and (3)P506. Check for open between:
  - (3)P506-21 and (3)P507-9,
  - (3)P506-8 and (3)P507-10,
  - (3)P506-30 and (3)P507-6,
  - (3)P506-32 and (3)P507-5.

**Does open exist?**

YES	Repair open wire. Go to paragraph 16-12.
NO	Go to step 2.
  
2. Check for open between:
  - (3)J507-5 and (3)J507-6,
  - (3)J507-9 and (3)J507-10.

**Does open exist?**

YES	Replace pylon actuator 3 (TM 1-1520-238-23).
NO	Go to step 3.

3. Check for short between:
  - (3)J507-6 and case,
  - (3)J507-9 and case.

**Does open exist?**

YES	Replace pylon actuator 3 (TM 1-1520-238-23).
NO	Go to step 4.
  
4. Check for short between:
  - (3)P506-8 and backshell,
  - (3)P506-21 and backshell,
  - (3)P506-30 and backshell,
  - (3)P506-32 and backshell.

**Does open exist?**

YES	Repair shorted wire. Go to paragraph 16-12.
NO	Go to step 5.
  
5. Detach (3)P507. Check for open between:
  - (3)J507-7 and (3)J507-8,
  - (3)J507-1 and (3)J507-2.

**Does open exist?**

YES	Replace pylon actuator 3 (TM 1-1520-238-23).
NO	Go to step 6.
  
6. Check for short between:
  - (3)J507-8 and case,
  - (3)J507-2 and case.

**Does open exist?**

YES	Replace pylon actuator 3 (TM 1-1520-238-23).
NO	Go to step 7.
  
7. Detach TB502-2-S and (3)P506. Check for open between: (3)P506-34 and wire and TB502-2-S.
 

**Does open exist?**

YES	Repair open wire. Go to paragraph 16-12.
NO	Go to step 8.

---

**16-19. RIGHT INBOARD PYLON - DOES NOT MOVE (cont)**

---

**16-19**

8. Check for short between:  
(3)P507-8 and backshell,  
(3)P507-7 and backshell,  
(3)P507-2 and backshell,  
(3)P507-1 and backshell.

**Does open exist?**

YES      Repair shorted wire.  
            Go to paragraph 16-12.

NO        Replace pylon actuator  
            controller 3  
            (TM 1-1520-238-23).

END OF TASK



**16-20. RIGHT OUTBOARD PYLON - DOES NOT MOVE**

**16-20**

**Tools:**

<u>Nomenclature</u>	<u>Part Number</u>
Tool Kit, Electrical Repairer's	SC518099CLA06
Multimeter, Digital	AN/PSM-45

**Personnel Required:**

68X Armament/Electrical Systems Repairer

**References:**

TM 1-1520-238-23

**Equipment Conditions:**

<u>Ref</u>	<u>Condition</u>
TM 1-1520-238-23	Pylon fairing removed



**Turn off power before detaching or attaching wires and connectors. High current 28 VDC or 115 VAC is present. Failure to do so could result in death or serious injury.**

1. Detach (4)P506 and (4)P507. Check for open between:  
 (4)P506-21 and (4)P507-9,  
 (4)P506-8 and (4)P507-10,  
 (4)P506-30 and (4)P507-6,  
 (4)P506-32 and (4)P507-5.  
**Does open exist?**  
 YES      Repair open wire.  
             Go to paragraph 16-12.  
 NO        Go to step 2.
  
2. Check for open between:  
 (4)J507-5 and (4)J507-6,  
 (4)J507-9 and (4)J507-10.  
**Does open exist?**  
 YES      Replace pylon actuator 4  
             (TM 1-1520-238-23).  
 NO        Go to step 3.

3. Check for short between:  
 (4)J507-6 and case,  
 (4)J507-9 and case.  
**Does open exist?**  
 YES      Replace pylon actuator 4  
             (TM 1-1520-238-23).  
 NO        Go to step 4.
  
4. Check for short between:  
 (4)P506-8 and backshell,  
 (4)P506-21 and backshell,  
 (4)P506-30 and backshell,  
 (4)P506-32 and backshell.  
**Does open exist?**  
 YES      Repair shorted wire.  
             Go to paragraph 16-12.  
 NO        Go to step 5.
  
5. Detach (4)P507. Check for open between:  
 (4)J507-7 and (4)J507-8,  
 (4)J507-1 and (4)J507-2.  
**Does open exist?**  
 YES      Replace pylon actuator 4  
             (TM 1-1520-238-23).  
 NO        Go to step 6.
  
6. Check for short between:  
 (4)J507-8 and case,  
 (4)J507-2 and case.  
**Does open exist?**  
 YES      Replace pylon actuator 4  
             (TM 1-1520-238-23).  
 NO        Go to step 7.
  
7. Detach TB502-2-P and (4)P506. Check for open between (4)P506-34 and wire and TB502-2-P.  
**Does open exist?**  
 YES      Repair open wire.  
             Go to paragraph 16-12.  
 NO        Go to step 8.

---

**16-20. RIGHT OUTBOARD PYLON - DOES NOT MOVE (cont) (cont)**

---

**16-20**

8. Check for short between:  
(4)P507-8 and backshell,  
(4)P507-7 and backshell,  
(4)P507-2 and backshell,  
(4)P507-1 and backshell.

**Does open exist?**

- |     |   |
|-----|---|
| YES | Repair shorted wire.<br>Go to paragraph 16-12.                |
| NO  | Replace pylon actuator<br>controller 4<br>(TM 1-1520-238-23). |

END OF TASK

**16-21. EXTERNAL STORES JETTISON - MAINTENANCE OPERATIONAL CHECK**

**16-21**

<b>Tools:</b>		<b>Equipment Conditions:</b>	
<u>Nomenclature</u>	<u>Part Number</u>	<u>Ref</u>	<u>Condition</u>
Tool Kit, Electrical Repairer's	SC518099CLA06	TM 1-1520-238-23	All 4 pylon jettison firing cartridges - removed
Test Set, Pylon Ejector	2952D24395		External power application - Electrical
Multimeter, Digital	AN/PSM-45	TM 1-1520-238-T-4	Maintenance headset connected
<b>Personnel Required:</b>		Paragraph 16-10	EXTERNAL STORES - POWER UP completed
68X Armament/Electrical Systems Repairer	One person to assist		
<b>References:</b>			
TM 1-1520-238-T-4			
TM 1-1520-238-23			

**WARNING**

**Ensure that pylon jettison firing cartridges are removed from pylons before attempting troubleshooting. Failure to do so could result in death or serious injury.**

**NOTE**

- Refer to pilot station (fig. 16-12) and CPG station (fig. 16-13) for cockpit configuration and equipment.
- If referenced out of one paragraph or volume into another for additional troubleshooting, upon completion of the task, return to the maintenance operational check for the original paragraph or volume.

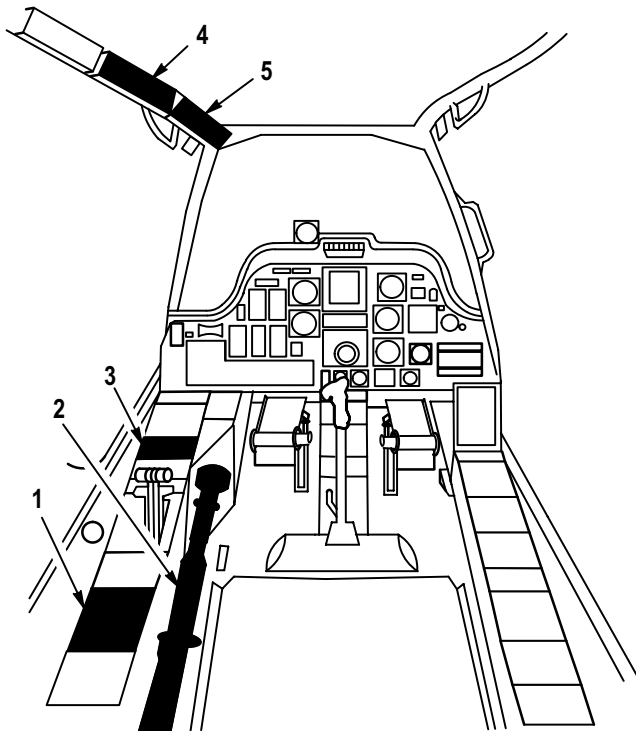

1. PILOT EXT LT / INTR LT PANEL
2. PILOT COLLECTIVE STICK
3. PILOT STORES JETT PANEL
4. PILOT CENTER CIRCUIT BREAKER PANEL
5. PILOT FORWARD CIRCUIT BREAKER PANEL

M71-202

Figure 16-12. Pilot Station

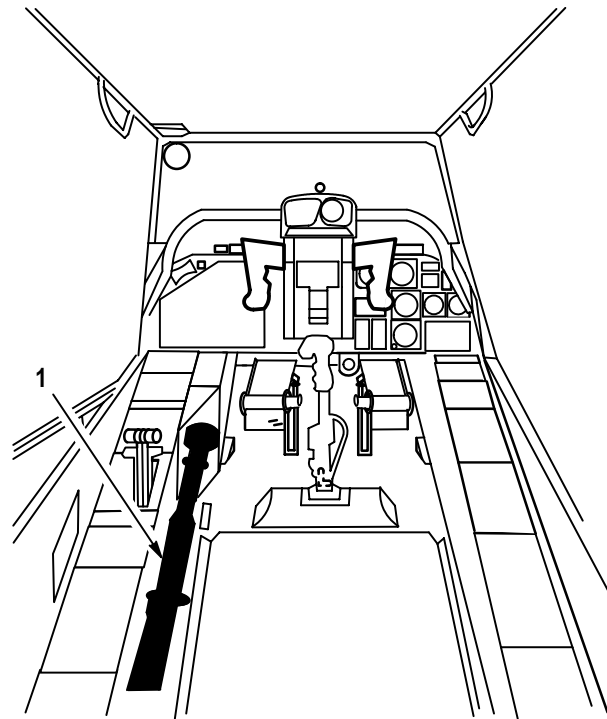

1. CPG COLLECTIVE STICK

M71-203

Figure 16-13. CPG Station

1. Perform visual check of pilot **STORES JETT** panel.
2. On pilot circuit breaker panels (fig. 16-14), open **MISSION JETT** and **JETT** circuit breakers.
3. Complete the maintenance operational check as follows:

16-21. EXTERNAL STORES JETTISON - MAINTENANCE OPERATIONAL CHECK (cont)

16-21

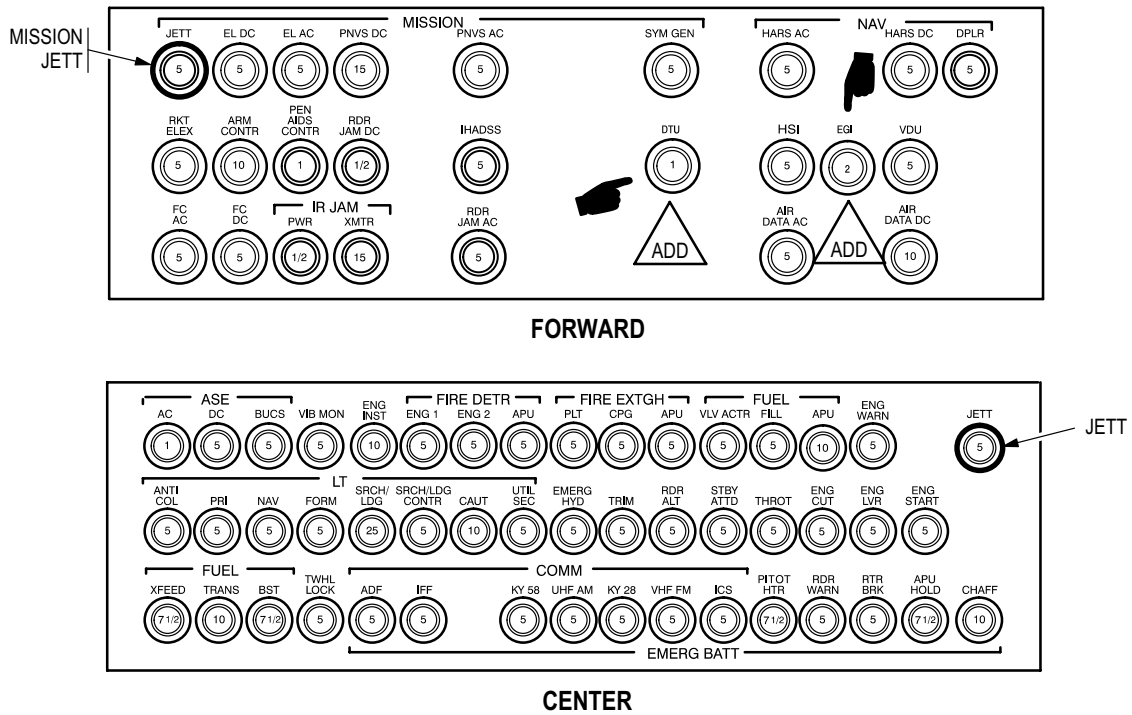
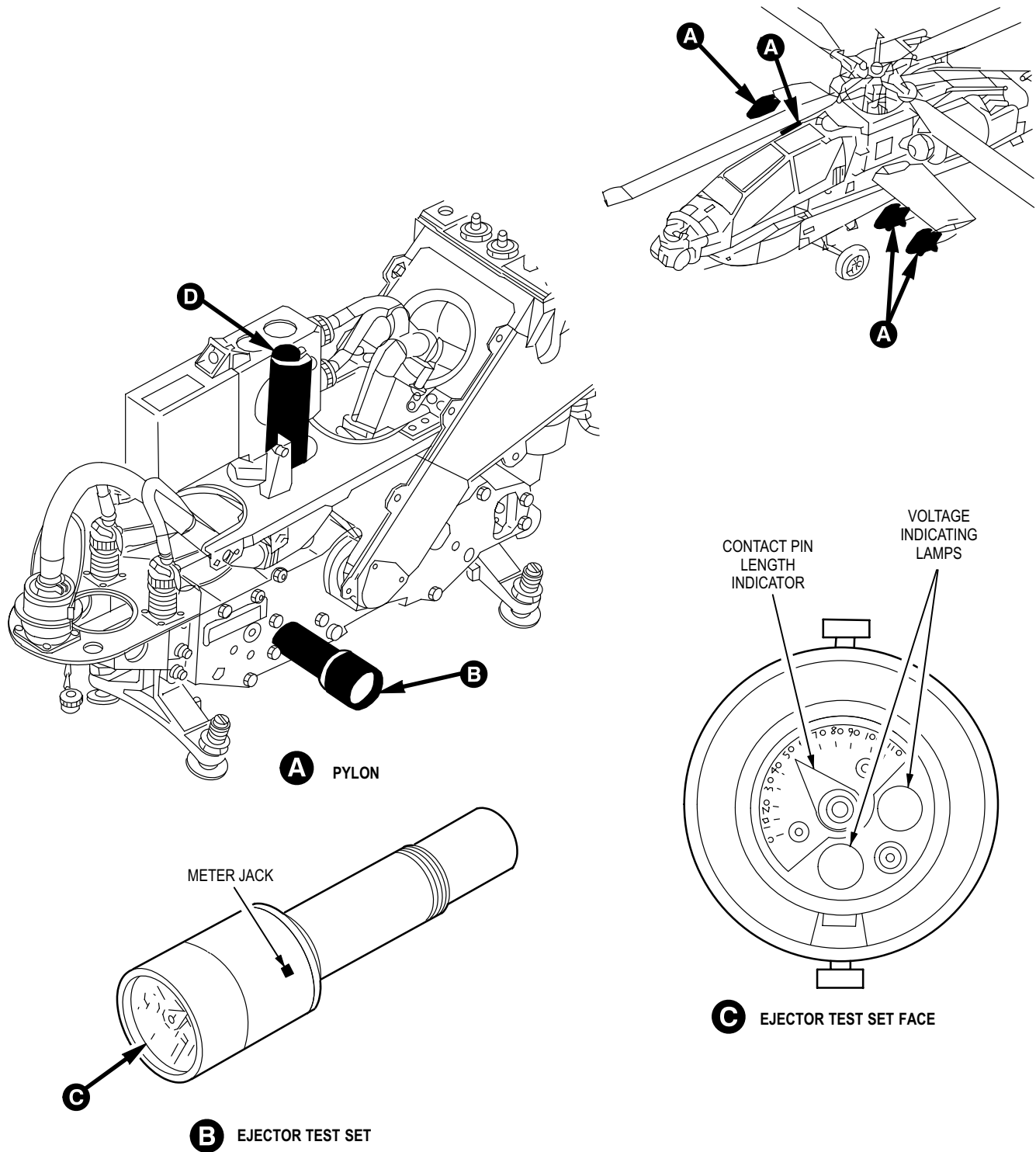

Figure 16-14. Pilot Circuit Breaker Panels

NOTE

The following procedure is common to all 4 pylons on the helicopter.

Task	Result
a. Install pylon external stores ejector test set (fig. 16-15) in pylon to be checked (TM 1-1520-238-23).	
b. Check the firing contact pin length (fig. 16-15) of pylon with test set installed.	If contact pin length is not between 0.025 and 0.065 inch on face of test set, replace pylon contact pin (TM 1-1520-238-23).
c. On pilot forward circuit breaker panel (fig. 16-14), close <b>MISSION JETT</b> circuit breaker.	If <b>MISSION JETT</b> circuit breaker does not stay closed, go to paragraph 16-31.



M71-206-1

Figure 16-15. Ejector Test Set and Firing Contact Pin (Sheet 1 of 2)

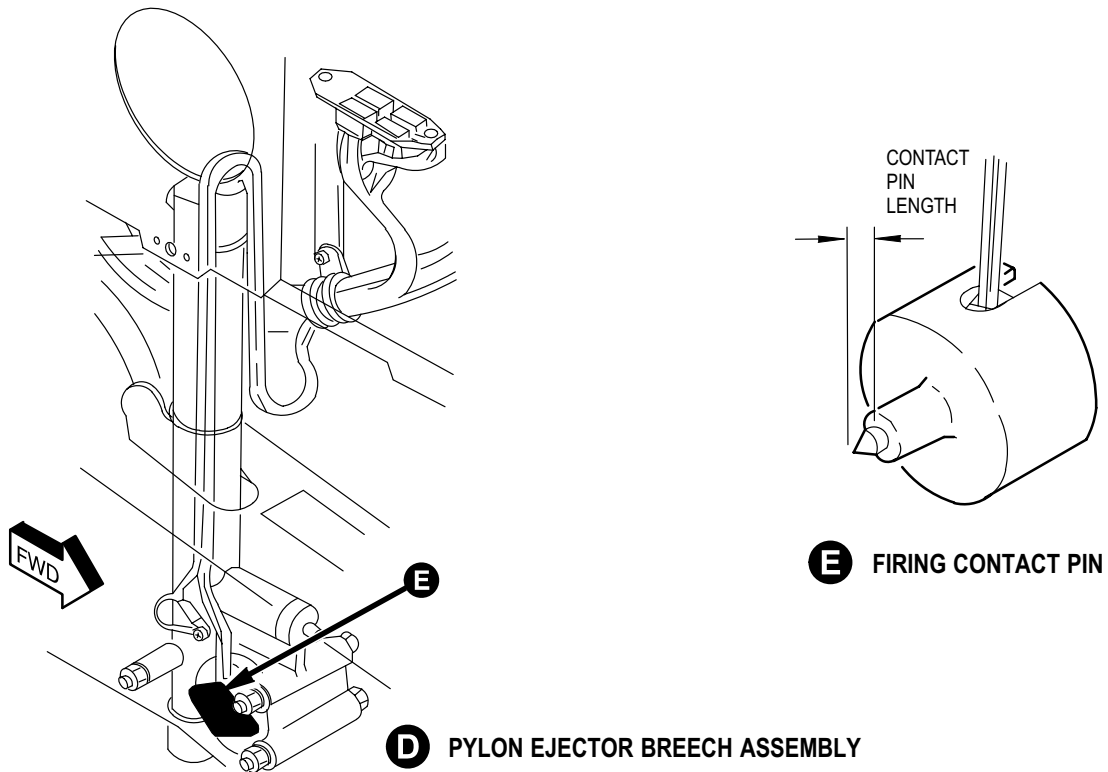

M71-206-2

Figure 16-15. Ejector Test Set and Firing Contact Pin (Sheet 2 of 2)

**CAUTION**

Do not hold stores jettison switches closed for longer than 2 seconds. If switches are closed for longer than 2 seconds, damage could occur.

**NOTE**

For precise voltage measurement, connect positive meter lead to jack on test set, and negative meter lead to ground. Set meter to 50 VDC scale.

Task	Result
<p>d. On pilot collective stick (fig. 16-16), lift <b>ST JTSN</b> switch cover and press release <b>ST JTSN</b> switch. Check for lamp on test set to light and meter to indicate 28 VDC.</p>	<p>If <b>MISSION JETT</b> circuit breaker does not stay closed, go to paragraph 16-34.</p> <p>If 28 VDC is present on meter and lamp does not light, replace pylon ejector test set.</p> <p>If 28 VDC is not present and lamp does not light, go to paragraph 16-23.</p>

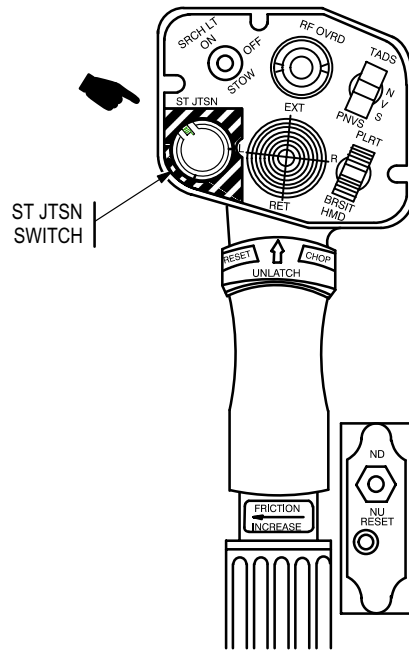

M71-207A

Figure 16-16. Collective Stick

Task	Result
------	--------

e. On pilot **STORES JETT** panel (fig. 16-17), close (up position) and release **STORES JETT** switch for pylon being checked. Check for 28 VDC and lamp on test set to light.

If 28 VDC is not present, go to paragraph 16-28.

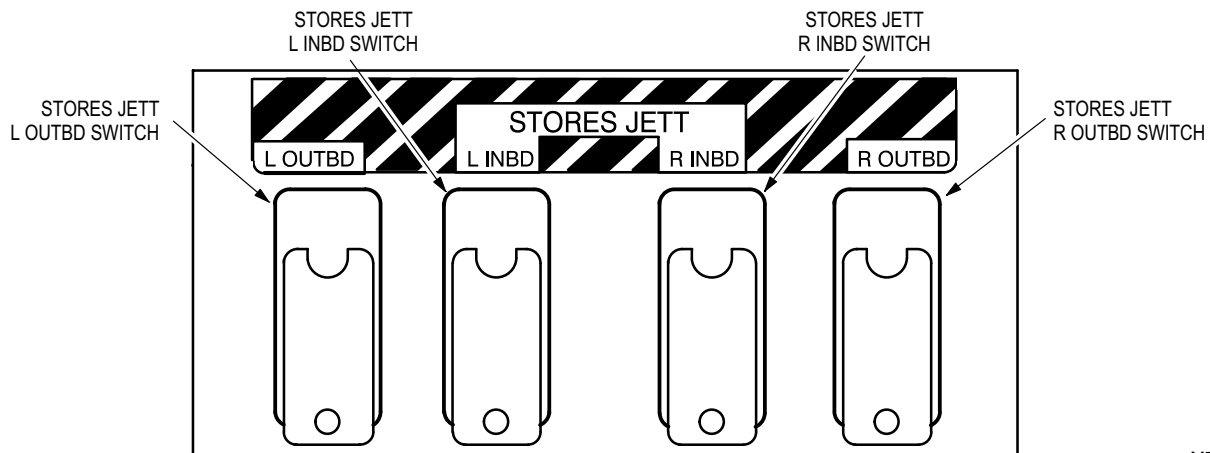

M71-208

Figure 16-17. Pilot STORES JETT Panel



**16-21. EXTERNAL STORES JETTISON - MAINTENANCE OPERATIONAL CHECK (cont)** **16-21**

Task	Result
f. On CPG collective stick (fig. 16-16), press and release <b>ST JTSN</b> switch. Check for 28 VDC and lamp on test set to light.	If 28 VDC is not present, go to paragraph 16-24.  If <b>MISSION JETT</b> circuit breaker does not stay closed, go to paragraph 16-35.
g. On pilot circuit breaker panels (fig. 16-14), close <b>JETT</b> circuit breaker and open <b>MISSION JETT</b> circuit breaker.	If <b>JETT</b> circuit breaker does not stay closed, go to paragraph 16-32.
h. On pilot collective stick, press and release <b>ST JTSN</b> switch. Check for 28 VDC and lamp on test set to light.	If 28 VDC is not present, go to paragraph 16-25.  If <b>JETT</b> circuit breaker does not stay closed, go to paragraph 16-33.
i. On CPG collective stick, press and release <b>ST JTSN</b> switch. Check for 28 VDC and lamp on test set to light.	If 28 VDC is not present, go to paragraph 16-26.  If <b>JETT</b> circuit breaker does not stay closed, go to paragraph 16-33.
j. Repeat steps a thru i for all other pylons.	
k. On pilot <b>EXT LT/INTR LT</b> panel (fig. 16-18), turn <b>L CSL</b> control to <b>BRT</b> .	If <b>STORES JETT</b> panel edge-light does not light, go to paragraph 16-27.

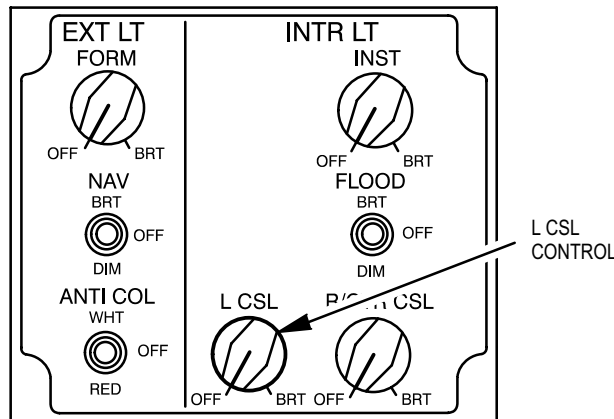

M71-209

**Figure 16-18. Pilot EXT LT/INTR LT Panel**

4. Perform EXTERNAL STORES - POWER DOWN (para 16-11).
5. Remove external power - electrical (TM 1-1520-238-23).
6. Perform pylon external stores ejector test set removal (TM 1-1520-238-23).
7. Install jettison firing cartridges in all 4 pylons (TM 1-1520-238-23).
8. Install fairings on all 4 pylons (TM 1-1520-238-23).
9. Disconnect maintenance headset (TM 1-1520-238-T-4).

END OF TASK

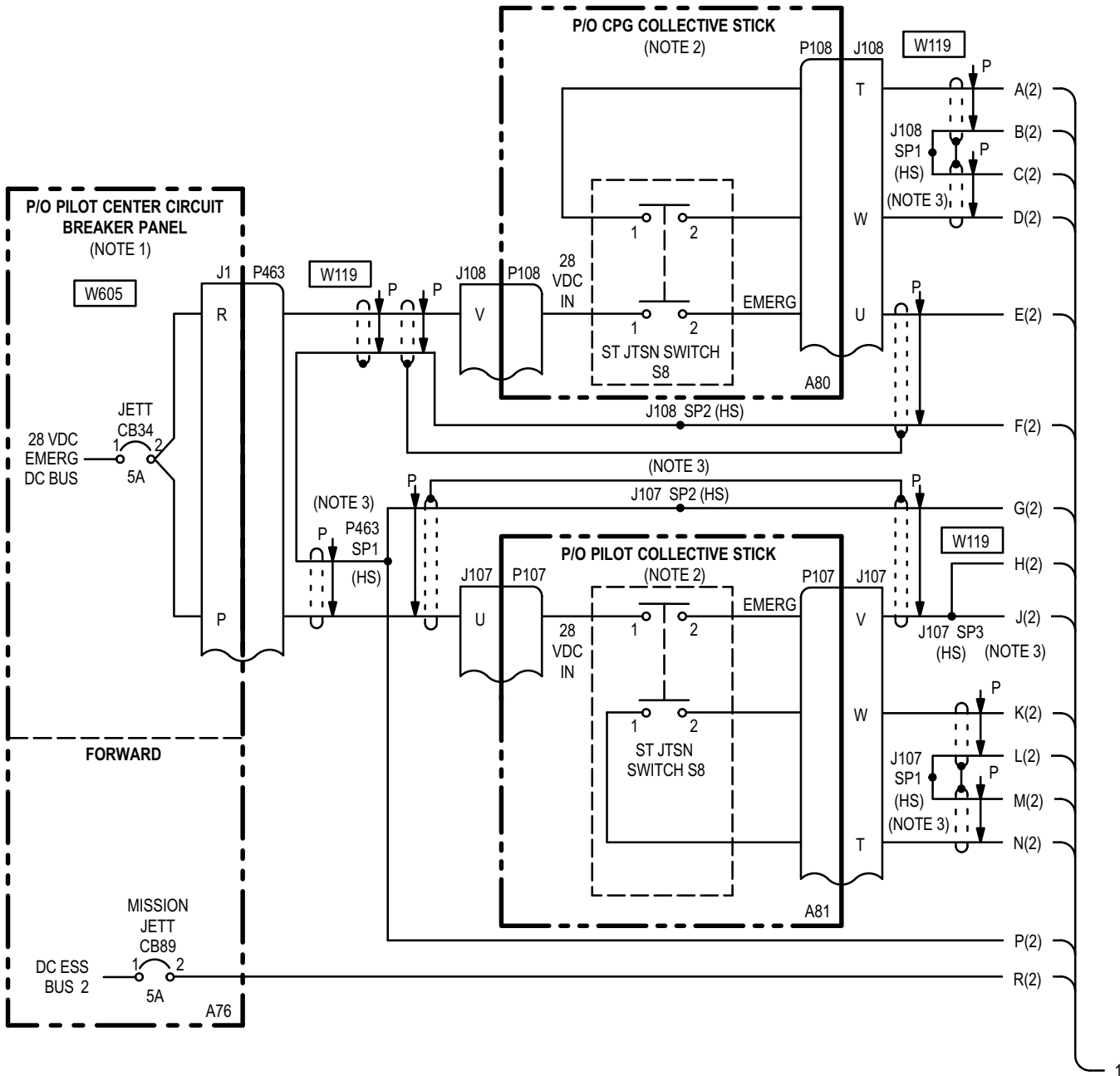

16-22. EXTERNAL STORES JETTISON - WIRING INTERCONNECT DIAGRAM (cont)

16-22

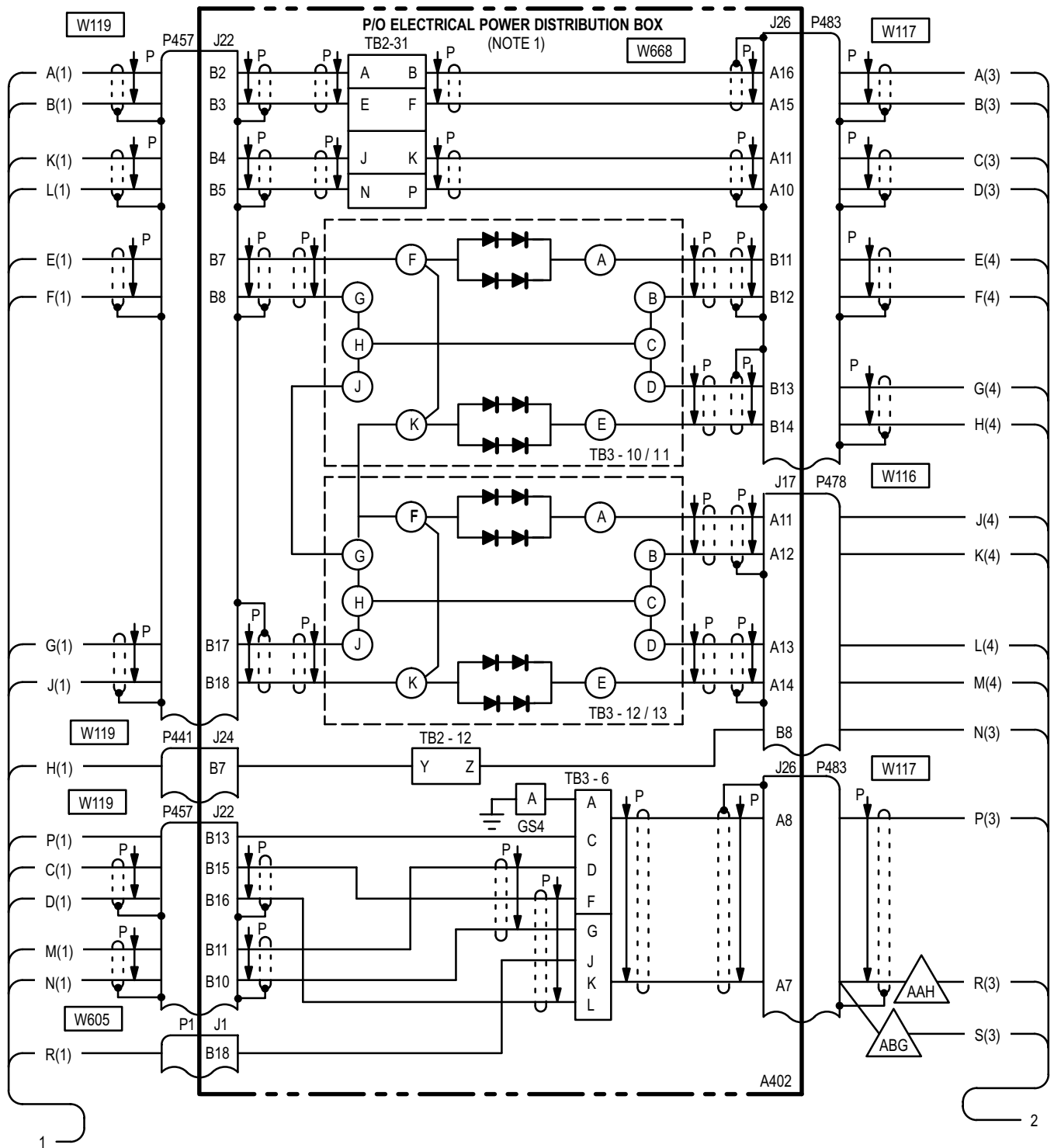

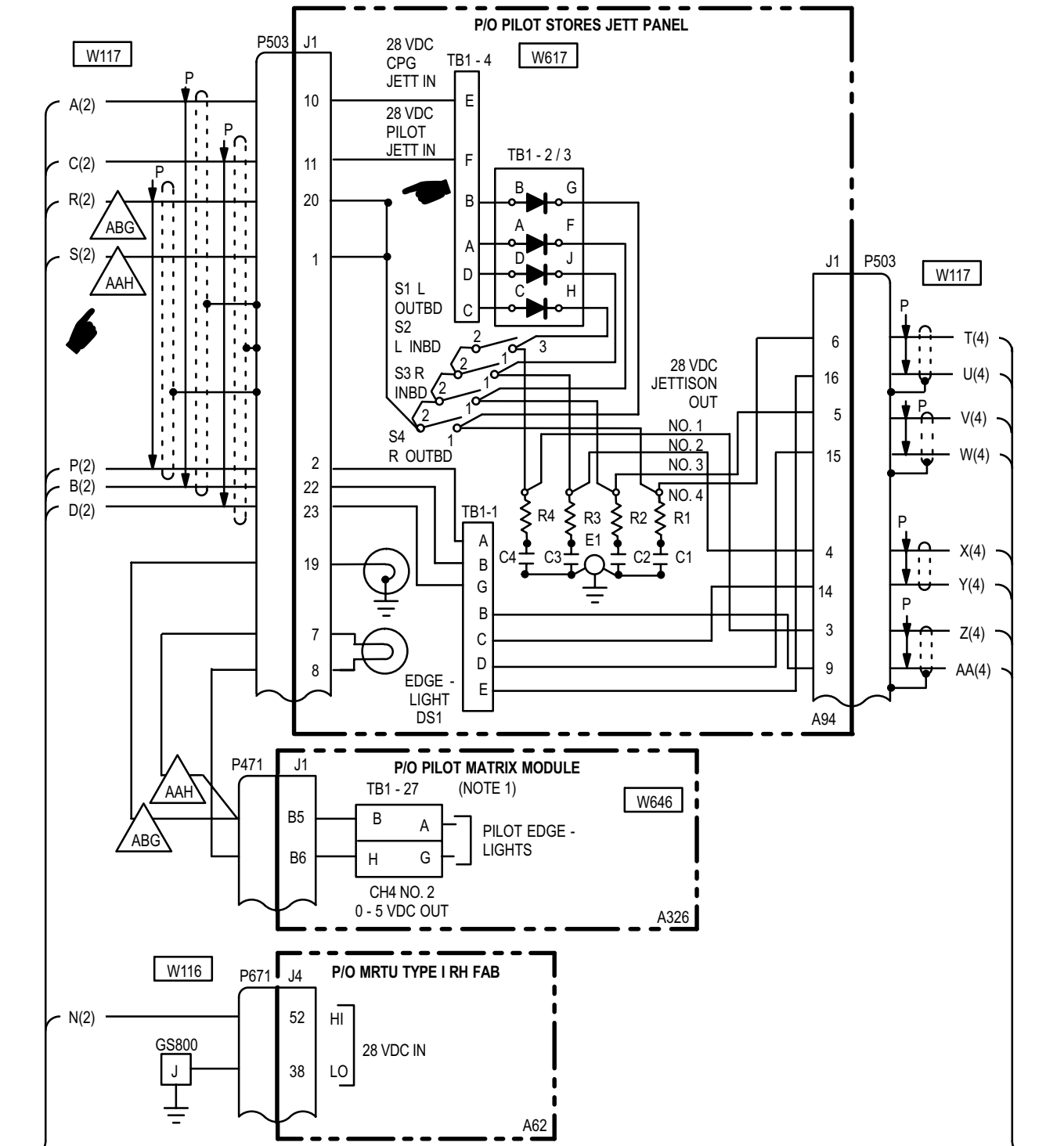

16-22. EXTERNAL STORES JETTISON - WIRING INTERCONNECT DIAGRAM (cont)

16-22

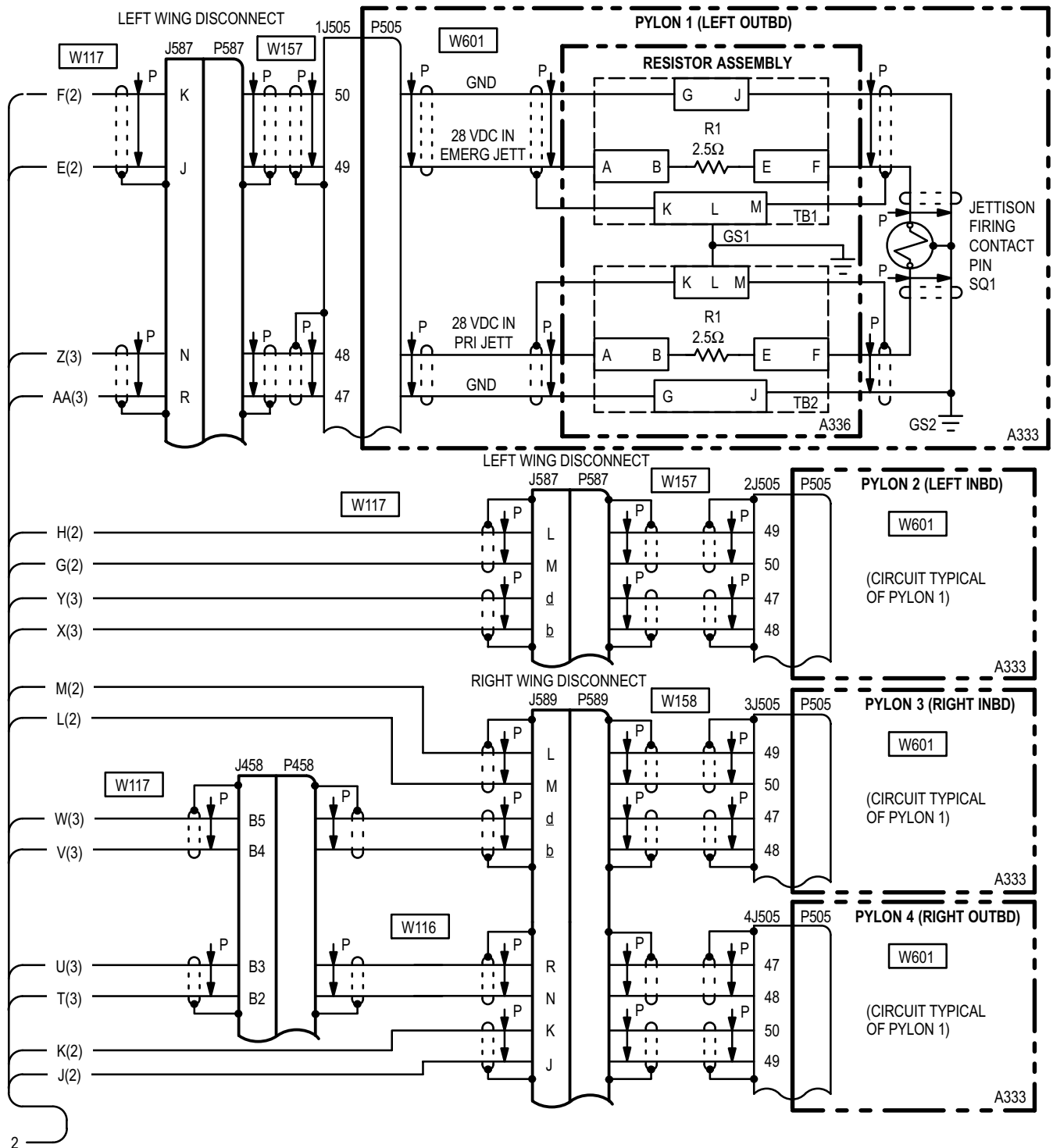

2

NOTES:

HIGHWAY USE: THE ALPHA CHARACTER IDENTIFIES A SPECIFIC LINE, AND THE NUMBER IN PARENTHESIS IDENTIFIES THE SHEET NUMBER WHERE THE SIGNAL TERMINATES.

1. ELECTRICAL SYSTEM (TM 1-1520-238-T-6).
2. FLIGHT CONTROL SYSTEM (TM 1-1520-238-T-7).
3. HS DESIGNATES A HARD SPLICE WHICH CANNOT BE DISCONNECTED.  
M DESIGNATES A SOFT SPLICE WHICH MAY BE DISCONNECTED FOR A WIRING CHECK.
4. FIRE CONTROL SYSTEM (TM 9-1230-476-20-2).

**16-23. PILOT ST JTSN SWITCH - NO PRIMARY JETTISON CONTROL VOLTAGE**

**16-23**

**Tools:**

<u>Nomenclature</u>	<u>Part Number</u>
Tool Kit, Electrical Repairer's	SC518099CLA06
Multimeter, Digital	AN/PSM-45

**Personnel Required:**

68X Armament/Electrical Systems Repairer  
One person to assist

**References:**

TM 1-1520-238-T-6  
TM 1-1520-238-23  
TM 9-1090-208-23-1

**Equipment Conditions:**

<u>Ref</u>	<u>Condition</u>
TM 1-1520-238-23	All 4 pylon jettison firing cartridges removed
TM 9-1090-208-23-1	<b>STORES JETT</b> panel removed

**WARNING**

- **Ensure that pylon jettison firing cartridges are removed from pylons before attempting troubleshooting. Failure to do so could result in death or serious injury.**
- **Turn off power before detaching or attaching wires and connectors. High current 28 VDC or 115 VAC is present. Failure to do so could result in death or serious injury.**

1. On pilot collective stick, press and hold **ST/JTSN** switch. Check for 28 VDC at P503-11.

**Is voltage present?**

YES	Go to paragraph 16-29 to troubleshoot jettison voltage to pylon.
NO	Go to step 2.

2. Press and hold **ST/JTSN** switch. Check for 28 VDC at J26-A11.

**Is voltage present?**

YES	Repair open wire between P483-A11 and P503-11. Go to paragraph 16-21.
NO	Go to step 3.

3. Check for 28 VDC between J107-T and ground.

**Is voltage present?**

YES	Go to step 4.
NO	Go to step 6.

4. Check for open between J107-W and J26-A11.

**Does open exist?**

YES	Go to step 5.
NO	Replace pilot <b>ST JTSN</b> switch (S8) (TM 1-1520-238-23).

5. Check for open between:

J107-W and P457-B4.  
(A402):  
J22-B4 and TB2-31-J,  
TB2-31-K and J26-A11.

**Does open exist?**

YES	Repair open wire. Go to paragraph 16-21.
NO	Replace terminal board (A402)TB2-31 (TM 1-1520-238-23).

---

**16-23. PILOT ST JTSN SWITCH - NO PRIMARY JETTISON CONTROL VOLTAGE (cont)**

---

**16-23**

6. Check for 28 VDC at  
(A402)J2-B10.

**Is voltage present?**

- |     |  |
|-----|--|
| YES | Repair open wire between<br>J107-T and P457-B10.<br>Go to paragraph 16-21. |
| NO  | Go to step 7.  |

7. Check for 28 VDC at P1-18.

**Is voltage present?**

- |     |   |
|-----|---|
| YES | Go to step 8.   |
| NO  | Refer to TM 1-1520-238-T-6 to<br>troubleshoot circuit protection<br>system (dc essential bus 2 -<br>pilot station). |

8. Check for open between (A402):  
J1-18 and TB3-6-J,  
J22-B10 and TB3-6-G.

**Does open exist?**

- |     |  |
|-----|--|
| YES | Repair open wire.<br>Go to paragraph 16-21.                  |
| NO  | Replace terminal board<br>(A402)TB3-6<br>(TM 1-1520-238-23). |

END OF TASK



**16-24. CPG ST JTSN SWITCH - NO PRIMARY JETTISON CONTROL VOLTAGE**

**16-24**

**Tools:**

<u>Nomenclature</u>	<u>Part Number</u>
Tool Kit, Electrical Repairer's	SC518099CLA06
Multimeter, Digital	AN/PSM-45

**Personnel Required:**

68X Armament/Electrical Systems Repairer  
One person to assist

**References:**

TM 1-1520-238-23  
TM 9-1090-208-23-1

**Equipment Conditions:**

<u>Ref</u>	<u>Condition</u>
TM 1-1520-238-23	All 4 pylon jettison firing cartridges removed
TM 9-1090-208-23-1	<b>STORES JETT</b> panel removed



- **Ensure that pylon jettison firing cartridges are removed from pylons before attempting troubleshooting. Failure to do so could result in death or serious injury.**
- **Turn off power before detaching or attaching wires and connectors. High current 28 VDC or 115 VAC is present. Failure to do so could result in death or serious injury.**

1. On CPG collective stick, press and hold **ST JTSN** switch. Check for 28 VDC at P503-10.  
**Is voltage present?**

YES	Go to paragraph 16-29 to troubleshoot jettison voltage to pylon.
NO	Go to step 2.

2. Press CPG **ST JTSN** switch. Check for 28 VDC at (A402)J26-A16.  
**Is voltage present?**

YES	Repair open wire between P483-A16 and P503-10. Go to paragraph 16-21.
NO	Go to step 3.
3. Check for 28 VDC at J108-W.  
**Is voltage present?**

YES	Go to step 4.
NO	Go to step 6.
4. Check for open between J108-T and (A402)J26-A16.  
**Does open exist?**

YES	Go to step 5.
NO	Replace CPG collective stick (TM 1-1520-238-23).
5. Check for open between: J108-T and P457-B2. (A402): J22-B2 and TB2-31-A, TB2-31-B and J26-A16.  
**Does open exist?**

YES	Repair open wire. Go to paragraph 16-21.
NO	Replace terminal board (A402)TB2-31 (TM 1-1520-238-23).
6. Check for 28 VDC at (A402)J22-B16.  
**Is voltage present?**

YES	Repair open wire between J108-W and P457-B16. Go to paragraph 16-21.
NO	Repair open wire between (A402): TB3-6-L and J22-B16. Go to paragraph 16-21.

END OF TASK

**16-25. PILOT ST JTSN SWITCH - NO EMERGENCY JETTISON CONTROL VOLTAGE**

**16-25**

**Tools:**

<u>Nomenclature</u>	<u>Part Number</u>
Tool Kit, Electrical Repairer's	SC518099CLA06
Multimeter, Digital	AN/PSM-45

**Personnel Required:**

68X Armament/Electrical Systems Repairer  
One person to assist

**References:**

TM 1-1520-238-T-6  
TM 1-1520-238-23

**Equipment Conditions:**

<u>Ref</u>	<u>Condition</u>
TM 1-1520-238-23	All 4 pylon jettison firing cartridges removed



- **Ensure that pylon jettison firing cartridges are removed from pylons before attempting troubleshooting. Failure to do so could result in death or serious injury.**
- **Turn off power before detaching or attaching wires and connectors. High current 28 VDC or 115 VAC is present. Failure to do so could result in death or serious injury.**

1. Check for 28 VDC at (A76)J1-P.

**Is voltage present?**

YES	Go to step 2.
NO	Refer to TM 1-1520-238-T-6 to troubleshoot circuit protection system (dc emergency bus - pilot station).

2. Check for 28 VDC at J107-U.

**Is voltage present?**

YES	Go to step 3.
NO	Repair open wire between J107-U and P463-P. Go to paragraph 16-21.

3. On pilot collective stick, press and hold **ST JTSN** switch. Check for 28 VDC at P457-B18.

**Is voltage present?**

YES	Go to paragraph 16-30 to troubleshoot jettison firing cartridge energizing voltage.
NO	Go to step 4.

4. Check for open between J107-V and P457-B18.

**Does open exist?**

YES	Repair open wire. Go to paragraph 16-21.
NO	Replace pilot <b>ST JTSN</b> switch (S8) (TM 1-1520-238-23).

END OF TASK

**16-26. CPG ST JTSN SWITCH - NO EMERGENCY JETTISON CONTROL VOLTAGE**

**16-26**

**Tools:**

<u>Nomenclature</u>	<u>Part Number</u>
Tool Kit, Electrical Repairer's	SC518099CLA06
Multimeter, Digital	AN/PSM-45

**Personnel Required:**

68X Armament/Electrical Systems Repairer  
One person to assist

**References:**

TM 1-1520-238-T-6  
TM 1-1520-238-23

**Equipment Conditions:**

<u>Ref</u>	<u>Condition</u>
TM 1-1520-238-23	All 4 pylon jettison firing cartridges removed



- **Ensure that pylon jettison firing cartridges are removed from pylons before attempting troubleshooting. Failure to do so could result in death or serious injury.**
- **Turn off power before detaching or attaching wires and connectors. High current 28 VDC or 115 VAC is present. Failure to do so could result in death or serious injury.**

1. Check for 28 VDC at (A76)J1-R.

**Is voltage present?**

YES	Go to step 2.
NO	Refer to TM 1-1520-238-T-6 to troubleshoot circuit protection system (dc emergency bus - pilot station).

2. Attach (A76)J1. Check for 28 VDC at J108-V.  
**Is voltage present?**

YES	Go to step 3.
NO	Repair open wire between J108-V and P463-R. Go to paragraph 16-21.

3. Attach J108. On CPG collective stick, press and hold **ST JTSN** switch. Check for 28 VDC at P457-B7.

**Is voltage present?**

YES	Go to paragraph 16-30 to troubleshoot jettison firing cartridge energizing voltage.
NO	Go to step 4.

4. Check for open between J108-U and P457-B7.  
**Does open exist?**

YES	Repair open wire. Go to paragraph 16-21.
NO	Replace CPG <b>ST JTSN</b> switch (S8) (TM 1-1520-238-23).

END OF TASK

**16-27. PILOT STORES JETT PANEL EDGE-LIGHT - DOES NOT LIGHT**

**16-27**

**Tools:**

<u>Nomenclature</u>	<u>Part Number</u>
Tool Kit, Electrical Repairer's	SC518099CLA06
Multimeter, Digital	AN/PSM-45

**Personnel Required:**

68X Armament/Electrical Systems Repairer  
One person to assist

**References:**

TM 1-1520-238-T-6  
TM 9-1090-208-23-1

**Equipment Conditions:**

<u>Ref</u>	<u>Condition</u>
TM 9-1090-208-23-1	<b>STORES JETT</b> panel removed.



**Turn off power before detaching or attaching wires and connectors. High current 28 VDC or 115 VAC is present. Failure to do so could result in death or serious injury.**

1. Check for 5 VDC between:  
**(AAH)** P503-7 and P503-8.  
**(ABG)** P503-19 and P503-8.

**Is voltage present?**

- |     |   |
|-----|---|
| YES | Replace <b>STORES JETT</b> panel edge-light (TM 9-1090-208-23-1). |
| NO  | Go to step 2.   |

2. Check for 5 VDC between (A326):  
TB1-27-B and TB1-27-H.

**Is voltage present?**

- |     |  |
|-----|--|
| YES | Repair open wire between: P503-7 and P451-B5, P503-8 and P471-B6. (A326): J1-B5 and TB1-27-B, J1-B6 and TB1-27-H. Go to paragraph 16-21. |
| NO  | Refer to TM 1-1520-238-T-6 to troubleshoot pilot and CPG edge-lights.  |

END OF TASK

**16-28. PILOT STORES JETT PANEL - NO JETTISON VOLTAGE TO PYLON**

**16-28**

**Tools:**

<u>Nomenclature</u>	<u>Part Number</u>
Tool Kit, Electrical Repairer's	SC518099CLA06
Multimeter, Digital	AN/PSM-45

**Personnel Required:**

68X Armament/Electrical Systems Repairer  
One person to assist

**References:**

TM 1-1520-238-23  
TM 9-1090-208-23-1

**Equipment Conditions:**

<u>Ref</u>	<u>Condition</u>
TM 9-1090-208-23-1	<b>STORES JETT</b> panel removed

**WARNING**

- **Ensure that pylon jettison firing cartridges are removed from pylons before attempting troubleshooting. Failure to do so could result in death or serious injury.**
- **Turn off power before detaching or attaching wires and connectors. High current 28 VDC or 115 VAC is present. Failure to do so could result in death or serious injury.**

1. Check for 5 VDC at:  
**(AAH)** P503-20.  
**(ABG)** P503-1.

**Is voltage present?**

YES	Go to step 2.
NO	Repair open wire between: (A402): J26-A7 and TB3-6-K. <b>(AAH)</b> P503-20 and P483-A7. <b>(ABG)</b> P503-1 and P483-A7. Go to paragraph 16-21.

2. On pilot **STORES JETT** panel:  
Close **L OUTBD** switch. Check for open between (A94): J1-1 and J1-3. Release **L OUTBD** switch.

Close **L INBD** switch. Check for open between (A94): J1-1 and J1-4. Release **L INBD** switch.

Close **R INBD** switch. Check for open between (A94): J1-1 and J1-5. Release **R INBD** switch.

Close **R OUTBD** switch. Check for open between (A94): J1-1 and J1-6. Release **R OUTBD** switch.

**Does open exist?**

YES	Replace defective switch (TM 9-1090-208-23-1).
NO	Go to step 3.

3. Close **L OUTBD** switch. Check for 28 VDC at 1J505-48.

Close **L INBD** switch. Check for 28 VDC at 2J505-48.

Close **R INBD** switch. Check for 28 VDC at 3J505-48.

Close **R OUTBD** switch. Check for 28 VDC at 4J505-48.

**Is voltage present?**

- YES        Go to step 4.
- NO        Repair open wire between:  
             1J505-48 and P503-3,  
             2J505-48 and P503-4,  
             3J505-48 and P503-5,  
             4J505-48 and P503-6.  
             Go to paragraph 16-21.

4. Detach wire at (A336)TB2-A and (A336)TB2-F. Check for open between: (A333)P505-48 and wire end at A, jettison firing contact pin and wire end at (A336)TB2-F.

**Does open exist?**

- YES        Repair open wire.  
             Go to paragraph 16-21.
- NO        Replace resistor R2 (TM 1-1520-238-23).

END OF TASK

**16-29. NO PRIMARY JETTISON CONTROL VOLTAGE TO JETTISON FIRING CARTRIDGE**

**16-29**

**Tools:**

<u>Nomenclature</u>	<u>Part Number</u>
Tool Kit, Electrical Repairer's	SC518099CLA06
Multimeter, Digital	AN/PSM-45

**Personnel Required:**

68X Armament/Electrical Systems Repairer  
One person to assist

**References:**

TM 1-1520-238-23  
TM 9-1090-208-23-1

**Equipment Conditions:**

<u>Ref</u>	<u>Condition</u>
TM 1-1520-238-23	All 4 pylon jettison firing cartridges removed Access provisions - LW9 cover and LW10 fairing removed Pilot seat - tilted forward

**WARNING**

- **Ensure that pylon jettison firing cartridges are removed from pylons before attempting troubleshooting. Failure to do so could result in death or serious injury.**
- **Turn off power before detaching or attaching wires and connectors. High current 28 VDC or 115 VAC is present. Failure to do so could result in death or serious injury.**

1. On pilot collective stick, press and hold **ST JTSN** switch. Check for 28 VDC:

J587-N,  
J587-b,  
J458-B2,  
J458-B4.

**Is voltage present?**

YES Go to step 2.  
NO Go to step 5.

2. Attach J587 and P458. On pilot collective stick, press and hold **ST JTSN** switch. Check for 28 VDC at:

J589-N,  
J589-b.

**Is voltage present?**

YES Go to step 3.  
NO Repair open wire between:  
J589-N and P458-B2,  
J589-b and P458-B4.  
Go to paragraph 16-21.

3. On pilot collective stick, press and hold **ST JTSN** switch. Check for 28 VDC at:

1J505-48,  
2J505-48,  
3J505-48,  
4J505-48.

**Is voltage present?**

YES Go to step 4.  
NO Repair open wire between:  
1J505-48 and J587-N,  
2J505-48 and J587-b,  
3J505-48 and J589-b,  
4J505-48 and J589-N.  
Go to paragraph 16-21.

4. Check for open between:  
(A336)P505-48 and (A336)TB2-A,  
(A336)TB2-F and (A333)SQ1.

**Does open exist?**

YES Repair open wire.  
Go to paragraph 16-21.  
NO Replace resistor R2  
(TM 1-1520-238-23).

---

16-29. NO PRIMARY JETTISON CONTROL VOLTAGE TO JETTISON FIRING CARTRIDGE (cont) 16-29

---

5. Check for open between:

J587-N and P503-3,  
J587-b and P503-4,  
J458-B4 and P503-5,  
J458-B2 and P503-6.

**Does open exist?**

- |     |   |
|-----|---|
| YES | Repair open wire.<br>Go to paragraph 16-21.                     |
| NO  | Replace pilot <b>STORES JETT</b><br>panel (TM 9-1090-208-23-1). |

END OF TASK



**16-30. NO EMERGENCY JETTISON CONTROL VOLTAGE TO JETTISON FIRING CARTRIDGE**

**16-30**

**Tools:**

<u>Nomenclature</u>	<u>Part Number</u>
Tool Kit, Electrical Repairer's	SC518099CLA06
Multimeter, Digital	AN/PSM-45

**Personnel Required:**

68X Armament/Electrical Systems Repairer  
One person to assist

**References:**

TM 1-1520-238-23

**Equipment Conditions:**

<u>Ref</u>	<u>Condition</u>
TM 1-1520-238-23	All 4 pylon jettison firing cartridges removed Access provisions - L200 and R200 panels removed

**WARNING**

- **Ensure that pylon jettison firing cartridges are removed from pylons before attempting troubleshooting. Failure to do so could result in death or serious injury.**
- **Turn off power before detaching or attaching wires and connectors. High current 28 VDC or 115 VAC is present. Failure to do so could result in death or serious injury.**

1. Press **ST JTSN** switch. Check for 28 VDC at (A402):  
J17-A11,  
J17-A14,  
J26-B11,  
J26-B14.

**Is voltage present?**

YES      Go to step 2.  
NO        GO to step 5.

2. Attach (A402): J17 and J26. On pilot collective stick, press and hold **ST JTSN** switch. Check for 28 VDC at:  
J587-J,  
J587-L,  
J589-J,  
J589-L.

**Is voltage present?**

YES      Go to step 3.  
NO        Repair open wire between:  
P478-A11 and J589-J,  
P478-A14 and J589-L,  
P483-B11 and J587-J,  
P483-B14 and J587-L.  
Go to paragraph 16-21.

3. Attach J587 and J589. On pilot collective stick, press and hold **ST JTSN** switch. Check for 28 VDC at J505-49 on 4 pylons.

**Is voltage present?**

YES      Go to step 4.  
NO        Repair open wire between:  
P589-J and 4J505-49,  
P589-L and 3J505-49,  
P587-J and 1J505-49,  
P587-L and 2J505-49.  
Go to paragraph 16-21.

4. Check for open between:  
(A333)P505-49 and (A336)TB1-A,  
(A336)TB1-F and (A333)SQ1.

**Does open exist?**

YES      Repair open wire.  
Go to paragraph 16-21.  
NO        Replace resistor R1  
(TM 1-1520-238-23).

---

**16-30. NO EMERGENCY JETTISON CONTROL VOLTAGE TO JETTISON FIRING  
CARTRIDGE (cont) (cont)**

---

16-30

## 5. Check for open between (A402):

J22-B7 and TB3-10/11-F,  
TB3-10/11-K and TB3-12/13-F,  
TB3-10/11-A and J26-B11,  
TB3-10/11-E and J26-B14,  
TB3-12/13-A and J17-A11,  
TB3-12/13-E and J17-A14,  
J22-B18 and TB3-12/13-K.

**Does open exist?**

- |     |  |
|-----|--|
| YES | Repair open wire.<br>Go to paragraph 16-21.                                  |
| NO  | Replace (A402):<br>TB3-10/11 or TB3-12/13 as<br>required (TM 1-1520-238-23). |

END OF TASK

**16-31. MISSION JETT CIRCUIT BREAKER (CB89) - DOES NOT STAY CLOSED**

**16-31**

**Tools:**

<u>Nomenclature</u>	<u>Part Number</u>
Tool Kit, Electrical Repairer's	SC518099CLA06
Multimeter, Digital	AN/PSM-45

**Personnel Required:**

68X Armament/Electrical Systems Repairer

**References:**

- TM 1-1520-238-T-6
- TM 1-1520-238-23
- TM 9-1090-208-23-1



- **Ensure that pylon jettison firing cartridges are removed from pylons before attempting troubleshooting. Failure to do so could result in death or serious injury.**
- **Turn off power before detaching or attaching wires and connectors. High current 28 VDC or 115 VAC is present. Failure to do so could result in death or serious injury.**

1. Open **MISSION JETT** circuit breaker (CB89). Check for short between P1-18 and ground.  
**Does short exist?**

YES	Refer to TM 1-1520-238-T-6 to troubleshoot circuit protection system (dc essential bus 2 - pilot station).
NO	Go to step 2.

2. Detach P457 and P483. Check for short between (A402)J1-18 and ground.

**Does short exist?**

YES	Repair shorted wire between (A402): TB3-6-J and J1-18, TB3-6-K and J26-A7, TB3-6-G and J22-B10, TB3-6-L and J22-B16. Go to paragraph 16-21.
NO	Go to step 3.

3. Check for short between P483-A7 and ground.

**Does short exist?**

YES	Go to step 7.
NO	Go to step 4.

4. Check for short between P457-B10 and ground.

**Does short exist?**

YES	Go to step 6.
NO	Go to step 5.

5. Detach J108. Check for short between P457-B16 and ground.

**Does short exist?**

YES	Repair shorted wire between P457-B16 and J108-W. Go to paragraph 16-21.
NO	Replace CPG collective stick (TM 1-1520-238-23).

6. Detach J107. Check for short between P457-B10 and ground.

**Does short exist?**

YES	Repair shorted wire between P457-B10 and J107-T. Go to paragraph 16-21.
NO	Replace pilot collective stick (TM 1-1520-238-23).

---

16-31. MISSION JETT CIRCUIT BREAKER (CB89) - DOES NOT STAY CLOSED (cont) (cont)

---

16-31

7. Detach P503. Check for short between P483-A7 and ground.

**Does short exist?**

- |     |   |
|-----|---|
| YES | Repair shorted wire between:<br><b>(AAH)</b> P483-A7 and P503-20.<br><b>(ABG)</b> P483-A7 and P503-1.<br>Go to paragraph 16-21. |
| NO  | Replace pilot <b>STORES JETT</b><br>panel (TM 9-1090-208-23-1).   |

END OF TASK

**16-32. JETT CIRCUIT BREAKER (CB34) - DOES NOT STAY CLOSED**

**16-32**

**Tools:**

<u>Nomenclature</u>	<u>Part Number</u>
Tool Kit, Electrical Repairer's	SC518099CLA06
Multimeter, Digital	AN/PSM-45

**Personnel Required:**

68X Armament/Electrical Systems Repairer

**References:**

TM 1-1520-238-T-6  
 TM 1-1520-238-23

**WARNING**

- **Ensure that pylon jettison firing cartridges are removed from pylons before attempting troubleshooting. Failure to do so could result in death or serious injury.**
- **Turn off power before detaching or attaching wires and connectors. High current 28 VDC or 115 VAC is present. Failure to do so could result in death or serious injury.**

1. Open **JETT** circuit breaker (CB34). Check for short between (A76):  
 J1-P and ground,  
 J1-R and ground.

**Does short exist?**

YES	Refer to TM 1-1520-238-T-6 to troubleshoot circuit protection system (dc emergency bus - pilot station).
NO	Go to step 2.

2. Check for short between P463-P and ground.

**Does short exist?**

YES	Go to step 4.
NO	Go to step 3.

3. Detach J108. Check for short between P463-R and ground.

**Does short exist?**

YES	Repair shorted wire between P463-R and J108-V. Go to paragraph 16-21.
NO	Replace CPG collective stick (TM 1-1520-238-23).

4. Detach J107. Check for short between P463-P and ground.

**Does short exist?**

YES	Repair shorted wire between P463-P and J107-U. Go to paragraph 16-21.
NO	Replace pilot collective stick (TM 1-1520-238-23).

END OF TASK

**16-33. JETT CIRCUIT BREAKER (CB34) - DOES NOT STAY CLOSED WITH PILOT OR CPG ST JTSN SWITCH PRESSED**

**Tools:**

<u>Nomenclature</u>	<u>Part Number</u>
Tool Kit, Electrical Repairer's	SC518099CLA06
Multimeter, Digital	AN/PSM-45

**Personnel Required:**

68X Armament/Electrical Systems Repairer

**References:**

- TM 1-1520-238-23
- TM 9-1230-476-20-1

**WARNING**

- **Ensure that pylon jettison firing cartridges are removed from pylons before attempting troubleshooting. Failure to do so could result in death or serious injury.**
- **Turn off power before detaching or attaching wires and connectors. High current 28 VDC or 115 VAC is present. Failure to do so could result in death or serious injury.**

1. Attach positive meter lead to (A402)J22-B18 and check for 0 to 50 ohms resistance between (A402)J22-B18 and ground.

**Is resistance present?**

- |     |               |
|-----|---------------|
| YES | Go to step 6. |
| NO  | Go to step 2. |

2. Check for short between P457-B18 and ground.

**Does short exist?**

- |     |               |
|-----|---------------|
| YES | Go to step 3. |
| NO  | Go to step 5. |

3. Detach P671. Check for short between P457-B18 and ground.

**Does short exist?**

- |     |   |
|-----|---|
| YES | Go to step 4.                                   |
| NO  | Replace MRTU type I (A62) (TM 9-1230-476-20-1). |

4. Detach J107. Check for short between P457-B18 and ground.

**Does short exist?**

- |     |  |
|-----|--|
| YES | Repair shorted wire between: P671-52 and P478-B8, P441-B7 and J107-SP3, J107-SP3 and P457-B18, J107-SP3 and J107-V. (A402): J17-B8 and TB2-12-Z, TB2-12-Y and J24-B7. Go to paragraph 16-21. |
| NO  | Replace pilot collective stick (TM 1-1520-238-23).   |

5. Detach P108. Check for short between P457-B7 and ground.

**Does short exist?**

- |     |  |
|-----|--|
| YES | Repair shorted wire between P457-B7 and J108-U. Go to paragraph 16-21. |
| NO  | Replace CPG collective stick (TM 1-1520-238-23).                       |

6. Detach P483 and P478. Check for short between (A402)J22-B18 and ground.

**Does short exist?**

- |     |  |
|-----|--|
| YES | Repair shorted wire between (A402): J22-B18 and TB3-12/13-K, TB3-12/13-E and J17-A14, TB3-12/13-A and J17-A11, TB3-12/13-F and TB3-10/11-K, TB3-10/11-E and J26-B14, TB3-10/11-A and J26-B11, TB3-10/11-F and J22-B7. Go to paragraph 16-21. |
| NO  | Go to step 7.  |

---

**16-33. JETT CIRCUIT BREAKER (CB34) - DOES NOT STAY CLOSED  
WITH PILOT OR CPG ST JTSN SWITCH PRESSED (cont)**

---

16-33

- |   |   |
|---|---|
| <p>7. In pylon 1, detach (A336):<br/>TB1-F and TB2-F. Check for short between<br/>P483-B11 and ground.<br/><b>Does short exist?</b></p> <p>YES      Repair shorted wire between:<br/>P483-B11 and J587-J,<br/>P587-J and 1J505-49,<br/>(A333)P505-49 and<br/>(A336)TB1-A,<br/>(A336)TB1-B and (A336)TB1-E.<br/>Go to paragraph 16-21.</p> <p>NO      Go to step 8.</p>            | <p>11. In pylon 3, detach wire from (A336):<br/>TB1-F and TB2-F. Check for short between<br/>P478-A14 and ground.<br/><b>Does short exist?</b></p> <p>YES      Repair shorted wire between:<br/>P478-A14 and J589-L,<br/>P589-L and 3J505-49,<br/>(A333)P505-49 and<br/>(A336)TB1-A,<br/>(A336)TB1-B and (A336)TB1-E.<br/>Go to paragraph 16-21.</p> <p>NO      Go to step 12.</p>  |
| <p>8. Check for short between end of wire at<br/>(A336)TB1-F and ground.<br/><b>Does short exist?</b></p> <p>YES      Repair shorted wire between<br/>(A336):<br/>TB1-F and TB2-F.<br/>Go to paragraph 16-21.</p> <p>NO      Go to step 9.</p>  | <p>12. Check for short between end of wire at<br/>(A336)TB1-F and ground.<br/><b>Does short exist?</b></p> <p>YES      Repair shorted wire between<br/>(A336):<br/>TB1-F and TB2-F.<br/>Go to paragraph 16-21.</p> <p>NO      Go to step 13.</p>  |
| <p>9. In pylon 2, detach wire from (A336):<br/>TB1-F and TB2-F. Check for short between<br/>P483-B14 and ground.<br/><b>Does short exist?</b></p> <p>YES      Repair shorted wire between:<br/>P483-B14 and J587-L,<br/>P587-L and 2J505-49,<br/>(A333)P505-49 and<br/>(A336)TB1-A,<br/>(A336)TB1-B and (A336)TB1-E.<br/>Go to paragraph 16-21.</p> <p>NO      Go to step 10.</p> | <p>13. In pylon 4, detach wire from (A336):<br/>TB1-F and TB2-F. Check for short between<br/>P478-A11 and ground.<br/><b>Does short exist?</b></p> <p>YES      Repair shorted wire between:<br/>P478-A11 and J589-J,<br/>P589-J and 4J505-49,<br/>(A333)P505-49 and<br/>(A336)TB1-A,<br/>(A336)TB1-B and (A336)TB1-E.<br/>Go to paragraph 16-21.</p> <p>NO      Repair shorted wire between<br/>(A336):<br/>TB1-F and TB2-F.<br/>Go to paragraph 16-21.</p> |
| <p>10. Check for short between end of wire at<br/>(A336)TB1-F and ground.<br/><b>Does short exist?</b></p> <p>YES      Repair shorted wire between<br/>(A336):<br/>TB1-F and TB2-F.<br/>Go to paragraph 16-21.</p> <p>NO      Go to step 11.</p>  |   |

END OF TASK

**16-34. MISSION JETT CIRCUIT BREAKER (CB89) - DOES NOT STAY CLOSED WITH PILOT ST JTSN SWITCH PRESSED**

**Tools:**

<u>Nomenclature</u>	<u>Part Number</u>
Tool Kit, Electrical Repairer's	SC518099CLA06
Multimeter, Digital	AN/PSM-45

**Personnel Required:**

68X Armament/Electrical Systems Repairer

**References:**

- TM 1-1520-238-23
- TM 9-1090-208-23-1



- **Ensure that pylon jettison firing cartridges are removed from pylons before attempting troubleshooting. Failure to do so could result in death or serious injury.**
- **Turn off power before detaching or attaching wires and connectors. High current 28 VDC or 115 VAC is present. Failure to do so could result in death or serious injury.**

1. Detach P503. Check for short between J107-W and ground.

**Does short exist?**

- |     |  |
|-----|--|
| YES | Repair shorted wire between: J107-W and P457-B4, P483-A11 and P503-11. (A402): J22-B4 and TB2-31-J. TB2-31-K and J26-A11. Go to paragraph 16-21. |
| NO  | Go to step 2.  |

2. Check for short between:

- P503-3 and ground,
- P503-4 and ground,
- P503-5 and ground,
- P503-6 and ground,
- 1J505-48 and ground,
- 2J505-48 and ground,
- 3J505-48 and ground,
- 4J505-48 and ground.

**Does short exist?**

- |     |   |
|-----|---|
| YES | Repair shorted wire. Go to paragraph 16-21. |
| NO  | Go to step 3.                               |

3. Check for short to ground between (A333)P505-48 and jettison firing contact pin on each pylon.

**Does short exist?**

- |     |  |
|-----|--|
| YES | Replace defective resistor assembly (A336) (TM 1-1520-238-23). |
| NO  | Go to step 4.  |

4. On pilot collective stick, press and hold **ST JTSN** switch. Check for short between P107-W and ground.

**Does short exist?**

- |     |  |
|-----|--|
| YES | Replace collective stick (TM 1-1520-238-23).           |
| NO  | Replace <b>STORES JETT</b> panel (TM 9-1090-208-23-1). |

END OF TASK



**16-35. MISSION JETT CIRCUIT BREAKER (CB89) - DOES NOT STAY CLOSED WITH CPG ST JTSN SWITCH PRESSED**

16-35

**Tools:**

<u>Nomenclature</u>	<u>Part Number</u>
Tool Kit, Electrical Repairer's	SC518099CLA06
Multimeter, Digital	AN/PSM-45

**Personnel Required:**

68X Armament/Electrical Systems Repairer  
One person to assist

**References:**

TM 1-1520-238-23  
TM 9-1090-208-23-1

2. Check for short between:

J108-T and ground,  
P457-B2 and ground,  
P483-A16 and ground,  
P503-10 and ground.  
(A402):  
J22-B2 and ground,  
TB2-31-A and ground,  
TB2-31-B and ground,  
J26-A16 and ground.

**Does short exist?**

YES Repair shorted wire.  
Go to paragraph 16-21.

NO Replace pilot **STORES JETT** panel (TM 9-1090-208-23-1).

**WARNING**

- **Ensure that pylon jettison firing cartridges are removed from pylons before attempting troubleshooting. Failure to do so could result in death or serious injury.**
- **Turn off power before detaching or attaching wires and connectors. High current 28 VDC or 115 VAC is present. Failure to do so could result in death or serious injury.**

1. On CPG collective stick, press and hold **ST JTSN** switch. Check for short between (A80)P108-T and ground.

**Does short exist?**

YES Replace CPG collective stick (TM 1-1520-238-23).

NO Go to step 2.

END OF TASK



## APPENDIX A

### REFERENCES

#### A-1. SCOPE.

This appendix contains a list of all official publications referenced in manuals TM 1-1520-238-T-4 through TM 1-1520-238-T-8.

#### A-2. REFERENCES.

##### TECHNICAL MANUALS

TM 1-1520-238-T-1	Aviation Unit Maintenance Manual for Army AH-64A Helicopter Fault Detection/Location System
TM 1-1520-238-T-2	Aviation Unit Maintenance Manual for Army AH-64A Helicopter Integrated Troubleshooting Master Failure Symptom Index
TM 1-1520-238-T-3	Aviation Unit Maintenance Manual for Army AH-64A Helicopter Multiplex Read Codes
TM 1-1520-238-T-4	Aviation Unit and Intermediate Troubleshooting Manual for Army AH-64A Helicopter
TM 1-1520-238-T-5	Aviation Unit and Intermediate Troubleshooting Manual for Army AH-64A Helicopter
TM 1-1520-238-T-6	Aviation Unit and Intermediate Troubleshooting Manual for Army AH-64A Helicopter
TM 1-1520-238-T-7	Aviation Unit and Intermediate Troubleshooting Manual for Army AH-64A Helicopter
TM 1-1520-238-T-8	Aviation Unit and Intermediate Troubleshooting Manual for Army AH-64A Helicopter
TM 1-1520-238-T-9	Aviation Unit and Intermediate Troubleshooting Manual for Army AH-64A Helicopter Theory of Operation
TM 1-1520-238-T-10	Aviation Unit Troubleshooting Manual for Army Model AH-64A Helicopter Wiring Diagrams
TM 3-4240-312-12&P	Operator's and Unit Maintenance Manual for Mask, Chemical-Biological: Aircraft, M43, Type I Small, Medium, Large, Extra Large; Type II Small, Medium, Large, Extra Large
TM 9-1090-208-23-1	Aviation Unit and Intermediate Maintenance Manual for Armament Subsystem, Helicopter: M139 Gun, Automatic, 30-Millimeter: M230 Rocket Management Subsystem, Inventory-Deployment: M140
TM 9-1090-208-23-2	Aviation Unit and Intermediate Troubleshooting Manual for Armament Subsystem, Helicopter: M139 Gun, Automatic, 30-Millimeter: M230 Rocket Management Subsystem, Inventory-Deployment: M140
TM 9-1230-476-20-1	Aviation Unit Maintenance Manual for Army AH-64A Helicopter, Fire Control System

**A-2 REFERENCES (cont).**

TM 9-1230-476-20-2	Aviation Unit Troubleshooting Manual for Army AH-64A Helicopter Fire Control System
TM 9-1270-221-23	Aviation Unit and Intermediate Maintenance Manual for Fire Control Subsystem, Helmet Directed: M142
TM 9-1427-475-20	Aviation Unit Maintenance Manual for Army AH-64A Helicopter Hellfire Missile Equipment (Point Target Weapon System) and Launcher Interface (Launcher, Guided Missile Aircraft, M272 Part No. 13009444)
TM 11-1520-238-23-1	Aviation Unit and Intermediate Maintenance Manual for Army Model AH-64A Helicopter Avionics Configuration
TM 11-1520-238-23-2	Aviation Unit and Intermediate Troubleshooting Manual for Army AH-64A Helicopter Avionics Configuration
TM 11-5855-265-20-2	Aviation Unit Maintenance Manual: Pilot Night Vision Sensor (PNVS) Assembly AN/AAQ-11, AH-64A Helicopter
TM 11-6140-203-14-2	Operators, Organizational, Direct Support, and General Support Maintenance Manual for Aircraft Nickel-Cadmium Batteries
TM 11-6605-300-23&P	Aviation Unit and Intermediate Maintenance Manual (Including Repair Parts and Special Tools List) Attitude Heading Reference System AN/ASN-134
TM 11-6625-3085-12-1	Operator and Aviation UNIT Maintenance (AVUM) Deployment, Operation and Teardown Procedures AH-64A Electronic Equipment Test Facility (EETF) OQ-290(V)2/MSM
TM 55-1500-323-24	Installation Practices, Aircraft Electric and Electronic Wiring
TM 1-1520-238-CL	Operators Checklist for Army AH-64A Helicopter
TM 1-1520-238-PM	Phased Maintenance Inspection Checklist for Army AH-64A Helicopter
TM 1-1520-238-PMS	AH-64A Helicopter 10-hour/14-Day Inspection Checklist
TM 1-1520-238-10	Operators Manual for Army AH-64A Helicopter
TM 1-1520-238-23	Aviation Unit and Aviation Intermediate Maintenance Manual for Army AH-64A Helicopter
TM 55-1730-229-12	Operator and Organizational Maintenance Manual Power Unit Aviation, Power Unit, Multi-Output GTED Electrical, Hydraulic, Pneumatic (AGPU) Wheel Mounted, Self-propelled. Towable, AC 400Hz, 3PH, 0.8PF, 115/200V, 30KW DC 28 VDC 700 Amps, Pneumatic 60 lbs/min at 40 psig, Hydraulic 15 gpm at 3000 psig, DOD Model MEP-360A
TM 55-2840-248-23	Aviation Unit and Intermediate Maintenance Manual, Engine, Aircraft Turboshift, Model T700-GE-700, T700-GE-701 and T700-GE-701C

# GLOSSARY

## SECTION I. ABBREVIATIONS AND ACRONYMS

AC	.....	Alternating Current
ACC	.....	Accessory/Accumulator
ADS	.....	Air Data System
ACT	.....	Action/Active
ACTG	.....	Actuating
ACTR	.....	Actuator
AD	.....	Air Data
ADF	.....	Automatic Direction Finder
AGPU	.....	Aviation Ground Power Unit
ALT	.....	Altimeter
AM	.....	Amplitude Modulation
AMMO	.....	Ammunition
AMP	.....	Ampere
APU	.....	Auxiliary Power Unit
APRCH	.....	Approach
ARCS	.....	Aerial Rocket Control System
ASE	.....	Automatic Stabilization Equipment
ASSY	.....	Assembly
ATTD	.....	Attitude
AUTO	.....	Automatic
AUX	.....	Auxiliary
AVA	.....	Aviation Vibration Analysis
AVIM	.....	Aviation Intermediate Maintenance
AVUM	.....	Aviation Unit Maintenance
AWS	.....	Area Weapon System

**ABBREVIATIONS AND ACRONYMS (cont)**

BATT	Battery
BIT	Built In Test
BK	Brake
BLO	Blower
BRK	Brake
BRT	Bright
BST	Boost
BTL	Bottle
BUCS	Backup Control System
BYP	Bypass
C	Celsius/Capacitor
CAB	Cabin
CAP	Capacitor
CAS	Command Augmentation System
CAUT	Caution
CB	Circuit Breaker
CBR	Chemical Biological Radiation
CCA	Closed Circuit Adapter
CCR	Contact Control Relay
CHGR	Charger
CKT	Circuit
CLR	Clear
CLTV	Collective
CM	Centimeter
COL	Collision
COM	Common
COMM	Communication/Common
CONTR	Control/Controller

**ABBREVIATIONS AND ACRONYMS (cont)**

CONUS .....	Continental United States
CPG .....	Copilot/Gunner
CRT .....	Cathode Ray Tube
CTR .....	Center
CSL .....	Console
DASE .....	Digital Automatic Stabilization Equipment
DASEC .....	Digital Automatic Stabilization Equipment Computer
DC .....	Direct Current
DCPLR .....	Decoupler
DEC .....	Digital Electronic Control
DEG .....	Degree
DES .....	Designation
DET .....	Detector
DGT .....	Dim/Test Panel Engine Instruments
DIO .....	Diode
DISCH .....	Discharge
DOD .....	Department of Defense
DPLR .....	Doppler
E .....	Empty
ECLC .....	Electrical Component Location and Configuration
ECS .....	Environmental Control System
ECU .....	Engine Control Unit
EETF .....	Electronic Equipment Test Facility
EGT .....	Engine Gas Turbine/Exhaust Gas Temperature
EHV .....	Electrohydraulic Valve
EL .....	Elevation
ELEC .....	Electrical
ELEK .....	Electronics

**ABBREVIATIONS AND ACRONYMS (cont)**

EMERG	Emergency
EMI	Electromagnetic Interference
EMP	Empty
ENCU	Environmental Control Unit
ENG	Engine
EXT	External/Extinguisher/Extend
EXTGH	Extinguisher
F	Fahrenheit
FAB	Forward Avionics Bay
FC	Fire Control
FCC	Fire Control Computer
FCDC	Flexible Confined Detonating Cord
FCS	Fire Control System
FD/LS	Fault Detection and Location System
FIP	Fault Isolation Procedure
FM	Frequency Modulation
FOD	Foreign Object Damage
FORM	Formation
FR	Front
FSC	Fuel Signal Conditioner
FT	Feet
FWD	Forward
G	Grams
GCU	Generator Control Unit
GCR	Generator Control Relay
GEN	Generator
GND	Ground
GPM	Gallons Per Minute



**ABBREVIATIONS AND ACRONYMS (cont)**

GRBX	.....	Gearbox
GSE	.....	Ground Service Equipment
HARS	.....	Heading Attitude Reference System
HDG	.....	Heading
HI	.....	High
HMU	.....	Hydromechanical Unit
HOD	.....	Heads Out Display
HS	.....	Hard Splice
HSI	.....	Horizontal Situation Indicator
HTR	.....	Heater
HYDR	.....	Hydraulic
HZ	.....	Hertz
ICS	.....	Intercommunication System
IDCDR	.....	Inductor
IFF	.....	Identification Friend or FOE
IGB	.....	Intermediate Gearbox
IGN	.....	Ignition
IHADSS	.....	Integrated Helmet and Display Sight System
INBD	.....	Inboard
IND	.....	Indicator
INSTR	.....	Instrument
INT	.....	Internal/Interior/Intermediate Gearbox
INTLK	.....	Interlock
INTMD	.....	Intermediate
INTL	.....	Internal
INTR	.....	Internal/Interior
IPAS	.....	Integrated Pressurized Air System
IPS	.....	Inches Per Second

**ABBREVIATIONS AND ACRONYMS (cont)**

IR	Infrared
JAM	Jammer
JETT	Jettison
JTSN	Jettison
K	Relay
KG	Kilogram
KIAS	Knots Indicated Airspeed
KVA	Kilo-Volt Amps
L	Left/Inductor
LB	Pound
LAT	Lateral
LCHR	Launcher
LDG	Landing
LDS	Load Demand Spindle
LH	Left-Hand
LO	Low
LOP	Low Oil Pressure
LONG	Longitudinal
LRU	Line Replaceable Unit
LVDT	Linear Variable Differential Transducer
LVL	Level
LVR	Lever/Louver
LW	Left Wing
LWC	Liquid Water Content
M	Meter/Hard Splice
MA	Missile Alert
MAINT	Maintenance
MAN	Manual

**ABBREVIATIONS AND ACRONYMS (cont)**

MAX	Maximum
MIN	Minute/Minimum
MLG	Main Landing Gear
MOC	Maintenance Operational Check
MOD	Moderate
MON	Monitor
MOT	Motor
MRTU	Multiplex Remote Terminal Unit
MSL	Missile
MTR	Motor
MUX	Multiplex
N	Nose
NATO	North Atlantic Treaty Organization
NAV	Navigation
NC	Normally Closed
ND	Nose Down
NG	Gas Generator Speed
NGB	Nose Gearbox
NI-CAD	Nickel Cadmium
NIU	Nitrogen Inerting Unit
NO	Normally Open
NOE	Nap Of Earth
NORM	Normal
NP	Engine Torque
NR	Rotor Speed
NRML	Normal
NU	Nose Up
OAS	Outside Air Sensor

**ABBREVIATIONS AND ACRONYMS (cont)**

OAT	Outside Air Temperature
OPR	Operate
ORT	Optical Relay Tube
ORIDE	Override
OUTBD	Outboard
OVERTEMP	Over Temperature
OVRD	Override
OVSP	Overspeed
PAS	Pressurized Air System
PEN	Penetration
PF	Picofarad
PLT	Pilot
PMG	Permanent Magnet Generator
PMP	Pump
PNVS	Pilot Night Vision Sensor
PPH	Pounds Per Hour
PRI	Primary
PSI	Pound-Force Per Square Inch
PSID	Pound-Force Per Square Inch Of Difference
PSIG	Pound-Force Per Square Inch Of Gage
PTO	Power Takeoff
PWR	Power
PYL	Pylon
PYLN	Pylon
QTY	Quantity
R	Right/Resistor
RAI	Remote Attitude Indicator
RCCB	Remote Control Circuit Breaker

**ABBREVIATIONS AND ACRONYMS (cont)**

RCDR	Recorder
RDR	Radar
RECT	Rectifier
REF	Reference
REL	Release
REM	Remaining
RES	Reservoir/Reserve
RET	Retract
RH	Right-Hand
RHI	Remote Heading Indicator
RKT	Rocket
RMI	Remote Magnetic Indicator
RPM	Revolutions Per Minute
RT	Right
RTR	Rotor
RW	Right Wing
SAI	Standby Attitude Indicator
SAS	Stability Augmentation System
SCU	Stabilization Control Unit
SDC	Signal Data Converter/Shaft Driven Compressor
SDD	Selectable Digital Display
SEC	Secondary/Seconds
SEL	Select
SHP	Shaft Horsepower
SMDC	Shielded Mild Detonating Cord
SNSR	Sensor
SP	Splice
SPA	Single Point Adapter

**ABBREVIATIONS AND ACRONYMS (cont)**

SPAD	Shear Pin Activated Decoupler
SPD	Speed
SRCH	Search
ST	Stores
STA	Station
STAB	Stabilator
STBY	Standby
SW	Switch
SYM	Symbol
T	Top/Transformer
TADS	Target Acquisition Designation Sight
TEMP	Temperature
TGB	Tail Rotor Gearbox
TGT	Turbine Gas Temperature
THROT	Throttle
TK	Tank
TLG	Tail Landing Gear
TM	Technical Manual
TNK	Tank
TR	Transformer Rectifier/Tail Rotor
TRANS	Transfer
TST	Test
TWHL	Tail Wheel
UHF	Ultra High Frequency
UTIL	Utility
VAC	Volts Alternating Current
VDC	Volts Direct Current
VDU	Video Display Unit

**ABBREVIATIONS AND ACRONYMS (cont)**

VHF	Very High Frequency
VIB	Vibration
VSI	Vertical Situation Indicator
WARN	Warning
WHT	White
WPR	Wiper
WSHLD	Windshield
XDCR	Transducer
XFEED	Crossfeed
XFER	Transfer
XFMR	Transformer
XFR	Transfer
XK	Relay Socket
XMN	Transmission
XMSN	Transmission
XMTR	Transmitter

## SECTION II. COMMON NAMES

<u>COMMON NAME</u>	<u>OFFICIAL NOMENCLATURE</u>
1G Spring Assembly .....	Cylinder, Assembly, Actuating
4-way Fuel Supply Check Valve .....	Valve, Check
Accelerometer .....	Accelerometer, Mechanical
Accessory Drive Oil Filter .....	Bowl, Filter
Accessory Drive Oil Pump .....	Pump, Rotary
AC Contactor .....	Relay, Electromagnetic
AC Generator .....	Generator, Alternating
Aft Fuel Cell .....	Aft Fuel Cell Assembly
Aft Fuel Quantity Transmitter .....	Transmitter, Liquid
Air Duct Assembly .....	Duct Assembly, Air C
Air Particle Separator .....	Separator, Air Particle
Air Pressure Manifold .....	Manifold, Fluid, Air circulating
Air Pressure Regulating Valve .....	Valve, Regulating, Fluid
Airspeed Indicator .....	Indicator, Airspeed
Airspeed Transducer .....	Transducer, Stabilator Airspeed
Air Vent/Pressure Relief Valve .....	Valve, Relief, Pressure
Anti Flail Assembly .....	Support Assembly, Damper
Anti-Ice Valve .....	Valve, Anti-Icing
APU Boost Pump .....	Pump Unit, Fuel, APU
<b>APU FIRE PULL</b> Handle .....	Switch, Push-Pull
<b>APU</b> Fire Test Panel .....	Auxiliary Power Unit, Fire Panel Assembly
APU Fuel Boost Pump .....	APU Fuel Pump Unit
APU Fuel Control .....	Fuel Control Assy
APU Fuel Shutoff Valve .....	Valve, Shutoff, APU



**COMMON NAMES (cont)**

<u>COMMON NAME</u>	<u>OFFICIAL NOMENCLATURE</u>
APU Input Flange .....	Flange, Drive, Auxiliary
ASE Panel .....	Automatic Stabilization Equipment Panel Assembly
Auxiliary Fuel Tank Air .....	Valve, Auxiliary Fuel
Auxiliary Fuel Transfer Shutoff Valve .....	Valve, Solenoid Shutoff Valve
Barometric Altimeter .....	Altimeter, Pressure
Battery .....	Battery Assembly
Battery Charger .....	Charger, Battery
Battery Relay .....	Relay, Battery
Blade De-Ice Relay .....	Relay, Electromagnetic
Blade De-Ice Remote Control Circuit Breaker .....	Circuit Breaker
Bleed Air Check Valve .....	Valve, Check
Bleed Air Relay .....	Relay, Electromagnetic
Bleed Air Shutoff Valve .....	Valve, Relief Pressure
Bleed Air Tube .....	Tube Assembly, Metal
Boost Pump Shutoff Valve .....	Valve, Solenoid
Brake Disc .....	Disk, Solid, Plain
Canopy Temperature Control .....	Control Box, Electronic Windshield Anti-Ice
Cap Assembly .....	Cap, Filler Opening
Clock .....	Clock, Aircraft, Mechanical
Collective Bellcrank .....	Bell Crank, Collective
Collective Mechanical Control Linkage .....	Push-Pull Rod Assembly
Collective Servocylinder .....	Main Rotor Servocylinder, Collective
Compressor Flange .....	Adaptor, Compressor
Controller .....	Temperature Control
Cooling Doors .....	Door Assembly
Cooling Fan And Coupling Assembly .....	Diffuser, Gearbox CO/Fan Centrifical
Cooling Turbine/Fan Assembly .....	Turbine, Aircraft Co

**COMMON NAMES (cont)**

<u>COMMON NAME</u>	<u>OFFICIAL NOMENCLATURE</u>
Coupling .....	Coupling, Assembly, Q
Coupling Assembly .....	Retainer, Bearing
CPG <b>ARM/SAFE</b> Indicator .....	Light Assembly, Indicator
CPG <b>AUX ANTI-ICE</b> Panel .....	Auxiliary Panel Assembly, CPG
CPG Caution/Warning Panel .....	Panel, Copilot/Gunner Annunciator Fault Function
CPG Circuit Breaker Panel 1 .....	Panel Assembly, Circuit Breaker No. 1
CPG Circuit Breaker Panel 2 .....	Panel Assembly, Circuit Breaker No. 2
CPG Collective Stick .....	Stick Assembly, Collective
CPG <b>ENG 1 FIRE PULL</b> Handle .....	Switch, Push-Pull
CPG <b>ENG 2 FIRE PULL</b> Handle .....	Switch, Push-Pull
CPG <b>INTR LT</b> Panel .....	Panel, Power distribution
CPG Master Caution/Warning Panel .....	Panel, Pilot (DS28) and Copilot/Gunner (DS31) Annunciator Fault Location
CPG Secondary Light .....	Utility and Glareshield Light Assembly
CPG Selectable Digital Display .....	Copilot/Gunner Selectable Parameter Digital Display Panel
CPG Utility Light .....	Utility and Glareshield Light Assembly
CPG Utility Light Mounting Bracket .....	Mounting, Base, Cockpit
CPG Windshield Wiper Converter .....	Converter, Windshield
CPG Windshield Wiper Flexdrive .....	Shaft Assembly, Flex
Cyclic Stick .....	Stick Assembly, Cyclic
DASE Computer (DASEC) .....	Computer, Flight Control
DC Bus Tie Contactor .....	Relay, Electromagnetic
Defog Shutoff Valve .....	Valve, Linear Direct
Dim/Test Panel .....	Dim/Test Control Panel Assembly
Directional Bellcrank .....	Bell Crank
Directional Feel Spring Assembly .....	Spring, Helical, Component
Directional Magnetic Brake Assembly .....	Brake Assembly, Magnetic

**COMMON NAMES (cont)**

<u>COMMON NAME</u>	<u>OFFICIAL NOMENCLATURE</u>
Directional Mechanical Control Linkage .....	Connecting Link, Rigging
Directional Pedal .....	Pedal, Control
Directional Servocylinder .....	Tail Rotor Servocylinder
Drive Link .....	Connecting Link, Assembly
Drive Shaft 5 .....	Shaft Assembly, Tail Rotor
Drive Shaft 6 .....	Shaft, Transmission
Dual Hydraulic Pressure Indicator .....	Indicator, Pressure
ECS Shutoff Valve .....	Valve, Shutoff Temperature Control
Ejector Assembly .....	Ejector Assembly, Rack P
Electrical Power Distribution Box .....	Distribution Box Installation, Electrical Power
Emergency Hydraulic Pressure Indicator .....	Indicator, Pressure
Emergency Power Check Overspeed Test Panel .....	Panel Assembly, Emergency
Enclosure .....	Bulkhead Enclosure
End Cap .....	Cap, Trailing Arm, La
Engine 1 Input Clutch .....	Clutch Assembly, Transmission
Engine Air Starter .....	Starter, Engine, Air
Engine Anti-Ice Bleed Start Valve .....	Anti-Icing Bleed and Start Valve
Engine Gas Generator ( <b>NG</b> ) RPM Indicator .....	Engine Gas Generator Indicator
Engine Inlet Anti-Ice Valve .....	Valve, Anti-Icing
Engine Inlet Cowling .....	Inlet Assembly, Air
Engine Nose Gearbox Assembly 1 .....	Gearbox, Engine Nose LH
Engine Nose Gearbox Assembly 2 .....	Gearbox, Engine Nose RH
<b>ENG OIL</b> Pressure Indicator .....	Engine Oil Pressure Indicator
Excitation Transformer .....	Transformer, Automatic
Exhaust Duct .....	Exhaust Mixer Duct
Exhaust Gas Temperature Thermocouple .....	Thermocouple
External Air Receptacle .....	Valve Assembly, Air, Star

**COMMON NAMES (cont)**

<u>COMMON NAME</u>	<u>OFFICIAL NOMENCLATURE</u>
External Fuel Tank .....	Auxiliary Wing Tank
External Power Contactor .....	Relay, Electromagnetic
External Power Monitor .....	Power Monitor, External
External Stores Elevation Controller .....	Controller, Ext Strs Stores
Feel Spring Assembly .....	Spring, Helical, Component
Fire Bottle Thermal Discharge Indicator .....	Indicator - Thermal D
Fire/Overheat Detector .....	Sensing Element, Fir
Flame Detector .....	Detector, Flame
Flame Detector Amplifier .....	Control, Amplifier
Fork Assembly .....	Fork, Tail Rotor/Fork, Landing, Gear, Tail
Forward Bearing Hanger Assembly .....	Hanger Assembly, FWD Brg
Forward Fuel Cell .....	Forward Fuel Cell Assembly
Forward Fuel Quantity Transmitter .....	Transmitter, Liquid
Fuel Boost Pump .....	Pump, Fuel Booster
Fuel Nozzle .....	Fuel Nozzle Assy
Fuel Panel .....	Panel Assembly, Fuel
Fuel Pressure Switch .....	Switch, Pressure
<b>FUEL</b> Quantity Indicator .....	Engine Fuel Quantity Indicator
Fuel Shutoff Valve .....	Valve, Shutoff
Fuel Signal Conditioner (FSC) .....	Conditioner, Signal
Fuel Solenoid Valve .....	Solenoid Valve
Fuel Transfer Pump .....	Pump, Submerged, Aircraft
Fuel Transfer Shutoff Valve .....	Valve, Solenoid
Fuel Transfer Valve .....	Valve, Fuel Transfer
Fuel Vent Shutoff Valve .....	Valve, Shutoff, Fuel
Generator Contactor .....	Relay, Electromagnetic
Generator Control Unit .....	Control, Generator

**COMMON NAMES (cont)**

<u>COMMON NAME</u>	<u>OFFICIAL NOMENCLATURE</u>
Gravity Filler Neck .....	Filler Neck
Ground Service Equipment (GSE) Panel .....	Equipment Panel Assembly
Housing .....	Housing Assembly
Hydraulic Starter .....	APU Hydraulic Starter
Ice Detector Relay .....	Relay, Electromagnetic
Ice Detector Sensor .....	Sensing Head, Ice De
Ice Detector Signal Processor .....	Signal Processor Unit Assembly, Ice Detector
Ice Detector Warm Air Supply Valve .....	Valve, Solenoid
Icing Severity Meter .....	Meter, Icing
Igniter Box .....	APU Ignition Exciter
Inlet Throttle Valve .....	Valve, Solenoid
Input Flange .....	Shaft, Shouldered
Intermediate Gearbox Assembly .....	Gearbox, Intermediate
Lamp .....	Lamp, Incandescent
Lateral Feel Spring Assembly .....	Spring, Helical, Component
Lateral Link .....	Link Assembly, Main Rotor
Lateral Magnetic Brake Assembly .....	Brake Assembly, Magnetic
Lateral Mechanical Control Linkage .....	Push-Pull Rod Assembly
Lateral Servocylinder .....	Main Rotor Servocylinder, Lateral
Left Anti-Collision Light .....	Light Subassembly, Anti-Collision
Left Crossfeed/Shutoff Valve .....	Valve, Solenoid
left Engine Nacelle Engine 1 .....	Nacelle Assembly, Engine LH
Left Main Landing Gear Assembly .....	Landing Gear Assembly LH
Linear Variable Differential Transducer (LVDT) .....	Transducer, Position
Longitudinal Mechanical Control Linkage .....	Push-Pull Rod Assembly
Longitudinal Servocylinder .....	Main Rotor Servocylinder, Longitudinal
Louver Actuator .....	Cylinder, Assembly, Actuator

**COMMON NAMES (cont)**

<u>COMMON NAME</u>	<u>OFFICIAL NOMENCLATURE</u>
Louver Assembly .....	Louver Assembly, Engine Cooling
Low Level Shutoff Valve .....	Valve, Solenoid
Lower Piston Assembly .....	Piston, Linear Actuator
Magnetic Brake Assembly .....	Brake Assembly, Magnetic
Magnetic Compass .....	Compass, Magnetic
Main Rotor Blade .....	Blade, Rotary Wing
Main Rotor Distributor Assembly .....	Power Dist Assembly
Main Transmission Assembly .....	Transmission, Main
Maintenance Light .....	Cable Assembly, Maintenance Light
Mixer Assembly .....	Rotor Controls, Upper Main
Navigation Light .....	Light, Navigation
Nitrogen Check Valve .....	Valve, Check
Nose Gearbox Fairing .....	Fairing Installation, Nose Gearbox
OAT Sensor .....	Detector
Outlet Check Valve .....	Valve, Check
Outlet Pressure Switch .....	Switch, Pressure
Output Flange .....	Flange Assembly, Drive
Outside Air Temperature Indicator .....	Indicator Assembly
Overboard Vent .....	Hose, Fuel Vent System
Pilot <b>ANTI ICE</b> Panel .....	Anti-Ice Panel Assembly, Pilot
Pilot <b>Arm/Safe</b> Indicator .....	Light Assembly, Indicator
Pilot Caution/Warning Panel .....	Panel, Pilot Annunciator Fault Function
Pilot Circuit Breaker Panel .....	Panel Installation, Circuit Breaker (Pilot)
Pilot Collective Stick .....	Stick Assembly, Collective
Pilot <b>ECS</b> Panel .....	Environmental Control System, Panel Assembly (Pilot)
Pilot <b>ELEC PWR</b> Panel .....	Panel Assembly, Electrical Power (Pilot)
Pilot <b>ENG 1 FIRE PULL</b> Handle .....	Switch, Push-Pull

**COMMON NAMES (cont)**

<u>COMMON NAME</u>	<u>OFFICIAL NOMENCLATURE</u>
Pilot <b>ENG 2 FIRE PULL</b> Handle .....	Switch, Push-Pull
Pilot <b>EXT LT/INTR LT</b> Panel .....	Panel, Power Distribution
Pilot Master Caution/Warning Panel .....	Panel, Pilot (DS28) and Copilot/Gunner (DS31) Annunciator Fault Location
Pilot Power Quadrant Panel .....	Pilot Power Quadrant Assembly
Pilot Radar Warning Control Panel .....	Panel,, Blank
Pilot Remote Transmitter Selector Panel .....	Communication System
Pilot Rockets Panel .....	Panel, Pilot Rocket
Pilot Secondary Light .....	Utility and Glareshield Light Assembly
Pilot Tail Wheel Lock Panel .....	Panel, Indicator Light
Pilot Utility Light .....	Utility and Glareshield Light Assembly
Pilot Utility Light Mounting Bracket .....	Mounting, Base, Cockpit
Pilot Valve .....	Valve, Solenoid
Pilot Windshield Wiper Converter .....	Converter, Windshield
Pilot Windshield Wiper Flexdrive .....	Shaft Assembly, Flex
Pitch Change Link .....	Connecting Link, Rigging
Pitch Link .....	Pitch Link Assembly
Pitch Magnetic Brake and Feel Spring Assembly .....	Brake Assy, Magnetic and Spring, Helical, Component
Pitch Rate Gyro .....	Gyroscope, Rate
Pitot Tube .....	Static Tube
Power Take-Off Clutch .....	Clutch Assy
Pressure Fuel Manifold .....	Manifold, Pressure, Fuel
Primary Exhaust Nozzle .....	Nozzle Assembly, Exhaust
Primary Fire Bottle Assembly .....	Extinguisher, Airkra
Primary Heat Exchanger .....	Heat Exchanger, Air
Primary Hydraulic Manifold .....	Manifold, Hydraulic
Primary Hydraulic Pump .....	Pump, Axial Pistons

**COMMON NAMES (cont)**

<u>COMMON NAME</u>	<u>OFFICIAL NOMENCLATURE</u>
Pylon Actuating Switch .....	Switch, Toggle, Pylon Ground Maintenance
Pylon Actuator .....	Cylinder Assembly
Pylon Actuator Controller .....	Controller Pylon
Rack Assembly .....	Rack, External Stores
Refuel/Defuel Check Valve .....	Valve, Fuel/Defuel
Refuel Indicator .....	Indicator, Refuel
Refueling Panel .....	Refueling and Transfer Fuel System Panel Assembly
Regulating Valve .....	Valve, Regulating, FL
Remote Attitude Indicator (RAI) .....	Indicator, Attitude
Reserve Fire Bottle Assembly .....	Extinguisher, Airera
Right Anti-Collision Light .....	Light Subassembly, Anti-Collision
Right Crossfeed/Shutoff Valve .....	Valve, Solenoid
Right Engine Nacelle Engine 2 .....	Nacelle Assembly, Engine RH
Right Main Landing Gear Assembly .....	Landing Gear Assembly RH
Roll Magnetic Brake and Feel Spring Assembly .....	Brake Assy, Magnetic and Spring, Helical, Component
Rotating Swashplate .....	Swashplate Assembly, Rotating
Rotor Blades De-Ice Controller .....	Controller, De-Icing
Rotor Brake Disk .....	Disk, Rotor, Brake
Scissor Assembly .....	Scissors Assembly, Main
Secondary Exhaust Nozzle .....	Nozzle Assembly, Suppres
Selectable Digital Display (SDD) Panel .....	Copilot/Gunner Selectable Parameter Digital Display Panel
Servoactuator .....	Servocylinder
Shaft Driven Compressor (SDC) .....	Compressor, Rotor Centrifugal
Shear Pin Activated Decoupler (SPAD) .....	SPAD Assembly
Shock Strut .....	Shock Strut Assembly



**COMMON NAMES (cont)**

<u>COMMON NAME</u>	<u>OFFICIAL NOMENCLATURE</u>
Signal Data Converter (SDC) .....	Data Converter Assembly
Stabilator Actuator Assembly .....	Actuator Assembly, Stabilator
Stabilator Control Unit (SCU) .....	Controller, Stabilator
Stabilator Position (STAB POS) Indicator .....	Indicator, Stabilization
Stabilator Position Transducer .....	Transducer, Stabilator Position
Stabilator Relay Box .....	Relay Assembly
Standby Attitude Indicator (SAI) .....	Indicator, Attitude
Static Mast .....	Mast, Assembly
Static Port .....	Static Tube
<b>STORES JETT</b> Panel .....	Panel Assembly, Stores Jettison
Sump Drain Valve .....	Cock, Poppet Drain
Surge Valve .....	Valve, Solenoid
Suspension Hook Assembly .....	Hook, Suspension Rac
Swashplate Assembly .....	Swashplate, Controller
Tail Rotor Gearbox Assembly .....	Gearbox, Tail Rotor
Tail Rotor Output Flange .....	Flange Assembly, Tail
Tail Wheel Lock Control Valve .....	Valve, Solenoid
Temperature Control Sensor .....	Control, Temperature
Temperature Control Valve .....	Valve, Shutoff Temperature Control
Thermal Switch .....	Thermal Switch Assembly, LH and RH
Thermistor .....	Sensor, Temperature
Thermostatic Switch .....	Switch, Thermostatic
Tire .....	Tire, Pneumatic
TLG Assembly .....	Tail Landing Gear Assembly
Torque Link .....	Connecting Link, Rigging
Trailing Arm Assemblies .....	Arm And Socket, Landing
Transfer/Rectifier .....	Power Transformer

**COMMON NAMES (cont)**

<u>COMMON NAME</u>	<u>OFFICIAL NOMENCLATURE</u>
Trim Brake Relay .....	Relay, Electromagnet
Turbine Gas Temperature ( <b>TGT</b> ) Indicator .....	Engine Turbine Gas Temperature Indicator
Turbine Speed Control .....	Control Unit, Turbine Engine Speed
Upper Piston Assembly .....	Piston Assembly, Shock Strut
Utility Air Receptacle .....	Coupling Half-Quick
Utility Heat Exchanger .....	Heat Exchanger, Air
Utility Hydraulic Accumulator Assembly .....	Manifold, Utility Accumulator
Utility Hydraulic Manifold .....	Manifold, Assembly
Utility Hydraulic Pump .....	Pump, Axial Piston
Utility Hydraulic Return Accumulator .....	Accumulator, Hydraulic
Vaneaxial Fan .....	Fan, Vaneaxial
Vent Tube .....	Tube, Vent, Fuel Cell
Vertical Speed Indicator ( <b>VSI</b> ) .....	Indicator, Vertical
Vertical Velocity Indicator .....	Indicator, Vertical
Wheel .....	Wheel Assembly, Main Landing Gear
Wheel Assembly .....	Wheel Assembly, Tail
Windshield Wiper Motor .....	Motor, Windshield Wiper
Yaw Magnetic Brake and Feel Spring Assembly .....	Brake Assembly, Magnetic and Spring, Helical, Component

## ALPHABETICAL INDEX

Para Title	Para. No.
<b>A</b>	
AC Electrical Power Generation - Maintenance Operational Check .....	9-12
AC Electrical Power Generation - Power Down .....	9-11
AC Electrical Power Generation - Power Up .....	9-10
AC Electrical Power Generation - Wiring Interconnect Diagram .....	9-13
AH-64A Helicopter, Introduction, Troubleshooting the .....	1-5
APU Fire Detection - Maintenance Operational Check .....	12-123
APU Fire Detection - Power Down .....	12-122
APU Fire Detection - Power Up .....	12-121
APU Fire Detection - Wiring Interconnect Diagram .....	12-124
Abbreviations and Acronyms .....	Glossary
Anti-Collision Lights - Maintenance Operational Check .....	9-72
Anti-Collision Lights - Wiring Interconnect Diagram .....	9-73
Audio Warning System - Maintenance Operational Check .....	9-397
Audio Warning System - Wiring Interconnect Diagram .....	9-398
Auxiliary Fuel System - Maintenance Operational Check .....	10-100
Auxiliary Fuel System - Wiring Interconnect Diagram .....	10-101
Auxiliary Power Unit, Controls and Indicators .....	15-6
Auxiliary Power Unit, Electrical Component Location and Configuration (ECLC) Index .....	15-9
Auxiliary Power Unit, Equipment Characteristics, Capabilities, and Features .....	15-1
Auxiliary Power Unit, Equipment Configuration .....	15-4
Auxiliary Power Unit, Equipment Data .....	15-3
Auxiliary Power Unit, Location and Description of Major Components .....	15-2
Auxiliary Power Unit - Maintenance Operational Check .....	15-12
Auxiliary Power Unit, Multiplex Read Codes .....	15-8
Auxiliary Power Unit - Power Down .....	15-11
Auxiliary Power Unit - Power Up .....	15-10
Auxiliary Power Unit, Safety, Care and Handling of Equipment .....	15-5
Auxiliary Power Unit, System Description .....	15-7

**ALPHABETICAL INDEX**

<b>Para Title</b>	<b>Para. No.</b>
Auxiliary Power Unit - Wiring Interconnect Diagram .....	15-13
<b>B</b>	
Battery - Maintenance Operational Check .....	9-42
Battery - Wiring Interconnect Diagram .....	9-43
Blade Tab Adjustment - In-Flight Tracking, Rotors, Main Rotor .....	5-13
<b>C</b>	
CPG Caution and Warning System - Maintenance Operational Check .....	9-666
CPG Caution and Warning System - Wiring Interconnect Diagram .....	9-667
CPG Edge-Lights - Maintenance Operational Check .....	9-134
CPG Edge-Lights - Wiring Interconnect Diagram .....	9-135
CPG Utility and Secondary Lights - Maintenance Operational Check .....	9-110
CPG Utility and Secondary Lights - Wiring Interconnect Diagram .....	9-111
Canopy Defog and Anti-Ice - Maintenance Operational Check .....	12-12
Canopy Defog and Anti-Ice - Power Down .....	12-11
Canopy Defog and Anti-Ice - Power Up .....	12-10
Canopy Defog and Anti-Ice - Wiring Interconnect Diagram .....	12-13
Capacitance and Indicating Test (Using TF 579 Test Set), Fuel Quantity System - .....	10-48
Capacitance and Indicating Test (Using PSD 60-1AF Test Set), Fuel Quantity System - .....	10-48A
Circuit Breaker Edge-Light Panels - Maintenance Operational Check .....	9-328
Circuit Breaker Edge-Light Panels - Wiring Interconnect Diagram .....	9-329
Circuit Breaker Reference List .....	9-150
Circuit Protection System (AC Essential Bus 1 - CPG Station) - Maintenance Operational Check .....	9-174
Circuit Protection System (AC Essential Bus 1 - CPG Station) - Wiring Interconnect Diagram .....	9-175
Circuit Protection System (AC Essential Bus 1 - Pilot Station) - Maintenance Operational Check .....	9-152
Circuit Protection System (AC Essential Bus 1 - Pilot Station) - Wiring Interconnect Diagram .....	9-153
Circuit Protection System (AC Essential Bus 2 - CPG Station) - Maintenance Operational Check .....	9-201

**ALPHABETICAL INDEX**

<b>Para Title</b>	<b>Para. No.</b>
Circuit Protection System (AC Essential Bus 2 - CPG Station) - Wiring Interconnect Diagram .....	9-202
Circuit Protection System (AC Essential Bus 2 - Pilot Station) - Maintenance Operational Check .....	9-191
Circuit Protection System (AC Essential Bus 2 - Pilot Station) - Wiring Interconnect Diagram .....	9-192
Circuit Protection System (DC Emergency Bus - CPG Station) - Maintenance Operational Check .....	9-306
Circuit Protection System (DC Emergency Bus - CPG Station) - Wiring Interconnect Diagram .....	9-307
Circuit Protection System (DC Emergency Bus - Pilot Station) - Maintenance Operational Check .....	9-265
Circuit Protection System (DC Emergency Bus - Pilot Station) - Wiring Interconnect Diagram .....	9-266
Circuit Protection System (DC Essential Bus 1 - CPG Station) - Maintenance Operational Check .....	9-217
Circuit Protection System (DC Essential Bus 1 - CPG Station) - Wiring Interconnect Diagram .....	9-218
Circuit Protection System (DC Essential Bus 1 - Pilot Station) - Maintenance Operational Check .....	9-208
Circuit Protection System (DC Essential Bus 1 - Pilot Station) - Wiring Interconnect Diagram .....	9-209
Circuit Protection System (DC Essential Bus 2 - Pilot Station) - Maintenance Operational Check .....	9-222
Circuit Protection System (DC Essential Bus 2 - Pilot Station) - Wiring Interconnect Diagram .....	9-223
Circuit Protection System (DC Essential Bus 3 - CPG Station) - Maintenance Operational Check .....	9-251
Circuit Protection System (DC Essential Bus 3 - CPG Station) - Wiring Interconnect Diagram .....	9-252
Circuit Protection System (DC Essential Bus 3 - Pilot Station) - Maintenance Operational Check .....	9-235
Circuit Protection System (DC Essential Bus 3 - Pilot Station) - Wiring Interconnect Diagram .....	9-236
Circuit Protection System (DC Ground Circuit Breakers - CPG Station) - Maintenance Operational Check .....	9-319

**ALPHABETICAL INDEX**

<b>Para Title</b>	<b>Para. No.</b>
Circuit Protection System (DC Ground Circuit Breakers - CPG Station) - Wiring Interconnect Diagram .....	9-320
Circuit Protection System (DC Ground Circuit Breakers - Pilot Station) - Maintenance Operational Check .....	9-314
Circuit Protection System (DC Ground Circuit Breakers - Pilot Station) - Wiring Interconnect Diagram .....	9-315
Collective Flight Controls - Rigging Operational Check .....	11-19
Common Names .....	Glossary
Controls and Indicators, Auxiliary Power Unit .....	15-6
Controls and Indicators, Drive System .....	6-6
Controls and Indicators, Electrical System .....	9-6
Controls and Indicators, Flight Control System .....	11-6
Controls and Indicators, Fuel System .....	10-6
Controls and Indicators, Hydraulic and Pneumatic Systems .....	7-6
Controls and Indicators, Instruments .....	8-6
Controls and Indicators, Landing Gear System .....	3-6
Controls and Indicators, Mission Equipment .....	16-6
Controls and Indicators, Power Plants .....	4-6
Controls and Indicators, Rotors .....	5-6
Controls and Indicators, Utility Systems .....	12-6

**D**

DASE - Maintenance Operational Check .....	11-23
DASE - Wiring Interconnect Diagram (BUCS Activated) .....	11-28
DASE - Wiring Interconnect Diagram (Collective) (BUCS Deactivated) .....	11-27
DASE - Wiring Interconnect Diagram (Pitch) (BUCS Deactivated) .....	11-24
DASE - Wiring Interconnect Diagram (Roll) (BUCS Deactivated) .....	11-25
DASE - Wiring Interconnect Diagram (Yaw) (BUCS Deactivated) .....	11-26
DASE/Stabilator - Power Down .....	11-11
DASE/Stabilator - Power Up .....	11-10
DC Electrical Power Generation - Maintenance Operational Check .....	9-23

## ALPHABETICAL INDEX

<b>Para Title</b>	<b>Para. No.</b>
DC Electrical Power Generation System - Wiring Interconnect Diagram .....	9-24
Directional Flight Controls - Rigging Operational Check .....	11-22
Drive System, Controls and Indicators .....	6-6
Drive System, Dynamic Operational Check .....	6-13
Drive System, Electrical Component Location and Configuration (ECLC) Index .....	6-9
Drive System, Equipment Characteristics, Capabilities, and Features .....	6-1
Drive System, Equipment Configuration .....	6-4
Drive System, Equipment Data .....	6-3
Drive System - Indicators Maintenance Operational Check .....	6-12
Drive System, Location and Description of Major Components .....	6-2
Drive System, Multiplex Read Codes .....	6-8
Drive System - Power Down .....	6-11
Drive System - Power Up .....	6-10
Drive System, Safety, Care and Handling of Equipment .....	6-5
Drive System, System Description .....	6-7
Drive System - Vibration Maintenance Operational Check .....	6-81
Drive System - Wiring Interconnect Diagram .....	6-14

## E

Electrical System, Electrical Component Location and Configuration (ECLC) Index .....	9-9
Electrical System, Controls and Indicators .....	9-6
Electrical System, Equipment Characteristics, Capabilities, and Features .....	9-1
Electrical System, Equipment Configuration .....	9-4
Electrical System, Equipment Data .....	9-3
Electrical System, Location and Description of Major Components .....	9-2
Electrical System, Multiplex Read Codes .....	9-8
Electrical System, Safety, Care and Handling Of Equipment .....	9-5
Electrical System, System Description .....	9-7
Engine 1 Fire Detection - Maintenance Operational Check .....	12-99

## ALPHABETICAL INDEX

<b>Para Title</b>	<b>Para. No.</b>
Engine 1 Fire Detection - Power Down .....	12-98
Engine 1 Fire Detection - Power Up .....	12-97
Engine 1 Fire Detection - Wiring Interconnect Diagram .....	12-100
Engine 2 Fire Detection - Maintenance Operational Check .....	12-112
Engine 2 Fire Detection - Power Down .....	12-111
Engine 2 Fire Detection - Power Up .....	12-110
Engine 2 Fire Detection - Wiring Interconnect Diagram .....	12-113
Engine Instruments - Maintenance Operational Check .....	8-10
Engine Instruments - Wiring Interconnect Diagram .....	8-11
Engine Anti-Ice - Maintenance Operational Check .....	12-25
Engine Anti-Ice - Wiring Interconnect Diagram .....	12-26
Environmental Control System - Description .....	13-7
Environmental Control System, Electrical Component Location and Configuration (ECLC) Index .....	13-9
Environmental Control System, Equipment Characteristics, Capabilities, and Features .....	13-1
Environmental Control System, Equipment Configuration .....	13-4
Environmental Control System, Equipment Data .....	13-3
Environmental Control System, Location and Description of Major Components .....	13-2
Environmental Control System - Maintenance Operational Check .....	13-12
Environmental Control System, Multiplex Read Codes .....	13-8
Environmental Control System - Power Down .....	13-11
Environmental Control System - Power Up .....	13-10
Environmental Control System, Safety, Care and Handling of Equipment .....	13-5
Environmental Control System - Wiring Interconnect Diagram .....	13-13
External Power - Power Down .....	9-47
External Power - Power Up .....	9-46
External Power and Ground Service Utility Receptacle - Maintenance Operational Check .....	9-48
External Power and Ground Service Utility Receptacle - Wiring Interconnect Diagram .....	9-49
External Stores - Power Down .....	16-11



## ALPHABETICAL INDEX

<b>Para Title</b>	<b>Para. No.</b>
External Stores - Power Up .....	16-10
External Stores Elevation Control - Maintenance Operational Check .....	16-12
External Stores Elevation Control - Wiring Interconnect Diagram .....	16-13
External Stores Jettison - Maintenance Operational Check .....	16-21
External Stores Jettison - Wiring Interconnect Diagram .....	16-22
<b>F</b>	
Fire Extinguishers - Maintenance Operational Check .....	12-133
Fire Extinguishers - Power Down .....	12-132
Fire Extinguishers - Power Up .....	12-131
Fire Extinguishers - Wiring Interconnect Diagram .....	12-134
Flight Control System - Maintenance Operational Check .....	11-12
Flight Control System, Controls and Indicators .....	11-6
Flight Control System, Electrical Component Location and Configuration (ECLC) Index .....	11-9
Flight Control System, Equipment Characteristics, Capabilities, and Features .....	11-1
Flight Control System, Equipment Configuration .....	11-4
Flight Control System, Equipment Data .....	11-3
Flight Control System, Location and Description of Major Components .....	11-2
Flight Control System, Multiplex Read Codes .....	11-8
Flight Control System, Safety, Care and Handling of Equipment .....	11-5
Flight Control System, System Description .....	11-7
Flight Controls - Rigging Operational Check, Collective .....	11-19
Flight Controls - Rigging Operational Check, Directional .....	11-22
Flight Controls - Rigging Operational Check, Lateral (Cyclic) .....	11-21
Flight Controls - Rigging Operational Check, Longitudinal (Cyclic) .....	11-20
Flight Instruments - Maintenance Operational Check .....	8-91
Flight Instruments - Wiring Interconnect Diagram .....	8-92
Force Trim - Wiring Interconnect Diagram .....	11-13
Formation Lights - Maintenance Operational Check .....	9-64

**ALPHABETICAL INDEX**

<b>Para Title</b>	<b>Para. No.</b>
Formation Lights - Wiring Interconnect Diagram .....	9-65
Fuel Crossfeed/Boost System - Maintenance Operational Check .....	10-17
Fuel Crossfeed/Boost System - Wiring Interconnect Diagram .....	10-18
Fuel Quantity Indication/Transfer - Maintenance Operational Check .....	10-47
Fuel Quantity Indication/Transfer - Wiring Interconnect Diagram .....	10-49
Fuel Quantity System - Capacitance and Indicating Test (Using TF 579 Test Set) .....	10-48
Fuel Quantity System - Capacitance and Indicating Test (Using PSD 60-1AF Test Set) .....	10-48A
Fuel System - Power Down .....	10-11
Fuel System - Power Up .....	10-10
Fuel System, Controls and Indicators .....	10-6
Fuel System, Electrical Component Location and Configuration (ECLC) Index .....	10-9
Fuel System, Equipment Characteristics, Capabilities, and Features .....	10-1
Fuel System, Equipment Configuration .....	10-4
Fuel System, Equipment Data .....	10-3
Fuel System, Location and Description of Major Components .....	10-2
Fuel System, Multiplex Read Codes .....	10-8
Fuel System, Safety, Care and Handling of Equipment .....	10-5
Fuel System, System Description .....	10-7

**G**

Gravity Refueling/Defueling - Maintenance Operational Check .....	10-72
---	-------

**H**

Helicopter Fuel System - Visual Check .....	10-12
Hydraulic and Pneumatic Systems, System Description .....	7-7
Hydraulic and Pneumatic Systems. Equipment Characteristics, Capabilities, and Features .....	7-1
Hydraulic and Pneumatic Systems, Controls and Indicators .....	7-6
Hydraulic and Pneumatic Systems, Electrical Component Location and Configuration (ECLC) Index .....	7-9
Hydraulic and Pneumatic Systems, Equipment Configuration .....	7-4
Hydraulic and Pneumatic Systems, Equipment Data .....	7-3

## ALPHABETICAL INDEX

<b>Para Title</b>	<b>Para. No.</b>
Hydraulic and Pneumatic Systems, Location and Description of Major Components .....	7-2
Hydraulic and Pneumatic Systems, Multiplex Read Codes .....	7-8
Hydraulic and Pneumatic Systems, Safety, Care and Handling of Equipment .....	7-5
<b>I</b>	
Instruments, Controls and Indicators .....	8-6
Instruments, Electrical Component Location and Configuration (ECLC) Index .....	8-9
Instruments, Equipment Characteristics, Capabilities, and Features .....	8-1
Instruments, Equipment Configuration .....	8-4
Instruments, Equipment Data .....	8-3
Instruments, Location and Description of Major Components .....	8-2
Instruments, Multiplex Read Codes .....	8-8
Instruments, Safety, Care and Handling of Equipment .....	8-5
Instruments, System Description .....	8-7
Introduction, Completing Troubleshooting .....	1-13
Introduction, During Troubleshooting .....	1-12
Introduction, Electrical Data .....	1-4
Introduction, Electronic Equipment Test Facility Testable (EETF) LRUs .....	1-16
Introduction, Failure Symptoms and Troubleshooting .....	1-6
Introduction, Fault Detection/Location System (FD/LS) Check .....	1-8
Introduction, Fault Isolation Procedures (FIPs) .....	1-10
Introduction, General Procedures - Summary .....	1-14
Introduction, Maintenance Headset Connection Procedure .....	1-17
Introduction, Maintenance Operational Checks (MOCs) .....	1-7
Introduction, Manual Content and Format .....	1-2
Introduction, Reference Manuals .....	1-3
Introduction, Roadmap Approach .....	1-9
Introduction, Scope .....	1-1
Introduction, Starting Troubleshooting .....	1-11

## ALPHABETICAL INDEX

Para Title	Para. No.
Introduction, Troubleshooting Line Replaceable Units (LRUs) off the Helicopter .....	1-15
Introduction, Troubleshooting the AH-64A Helicopter .....	1-5
<b>J</b>	
<b>K</b>	
<b>L</b>	
Landing Gear System, Controls and Indicators .....	3-6
Landing Gear System, Electrical Component Location and Configuration (ECLC) Index .....	3-9
Landing Gear System, Equipment Characteristics, Capabilities, and Features .....	3-1
Landing Gear System, Equipment Configuration .....	3-4
Landing Gear System, Equipment Data .....	3-3
Landing Gear System, Location and Description of Major Components .....	3-2
Landing Gear System, Multiplex Read Codes .....	3-8
Landing Gear System, Safety, Care and Handling of Equipment .....	3-5
Landing Gear System, System Description .....	3-7
Landing/Search Light - Maintenance Operational Check .....	9-82
Landing/Search Light - Wiring Interconnect Diagram .....	9-83
Lateral (Cyclic) Flight Controls - Rigging Operational Check .....	11-21
Longitudinal (Cyclic) Flight Controls - Rigging Operational Check .....	11-20
<b>M</b>	
Main Landing Gear - Maintenance Operational Check .....	3-10
Main Rotor - Track and Balance Troubleshooting Using AVA Equipment .....	5-22
Main Rotor - Track and Balance Using AVA Equipment .....	5-17
Maintenance Lights - Maintenance Operational Check .....	9-100
Maintenance Lights - Wiring Interconnect Diagram .....	9-101
Miscellaneous Instruments - Maintenance Operational Check .....	8-105
Miscellaneous Instruments - Wiring Interconnect Diagram .....	8-106
Mission Equipment, Controls and Indicators .....	16-6
Mission Equipment, Electrical Component Location and Configuration (ECLC) Index .....	16-9

## ALPHABETICAL INDEX

<b>Para Title</b>	<b>Para. No.</b>
Mission Equipment, Equipment Characteristics, Capabilities, and Features .....	16-1
Mission Equipment, Equipment Configuration .....	16-4
Mission Equipment, Equipment Data .....	16-3
Mission Equipment, Location and Description of Major Components .....	16-2
Mission Equipment, Multiplex Read Codes .....	16-8
Mission Equipment, Safety, Care and Handling of Equipment .....	16-5
Mission Equipment, System Description .....	16-7
Multiplex Read Codes, Hydraulic and Pneumatic Systems .....	7-8
Multiplex Read Codes, Auxiliary Power Unit .....	15-8
Multiplex Read Codes, Drive System .....	6-8
Multiplex Read Codes, Electrical System .....	9-8
Multiplex Read Codes, Environmental Control System .....	13-8
Multiplex Read Codes, Flight Control System .....	11-8
Multiplex Read Codes, Fuel System .....	10-8
Multiplex Read Codes, Instruments .....	8-8
Multiplex Read Codes, Landing Gear System .....	3-8
Multiplex Read Codes, Mission Equipment .....	16-8
Multiplex Read Codes, Power Plants .....	4-8
Multiplex Read Codes, Rotors .....	5-8
Multiplex Read Codes, Utility Systems .....	12-8
<b>N</b>	
Navigation Lights - Maintenance Operational Check .....	9-57
Navigation Lights - Wiring Interconnect Diagram .....	9-58
Nitrogen Inerting System - Maintenance Operational Check .....	10-67
Nitrogen Inerting System - Wiring Interconnect Diagram .....	10-68
<b>O</b>	
<b>P</b>	
Pilot and CPG Caution and Warning Panels, Indicators Functional Data .....	9-333

## ALPHABETICAL INDEX

<b>Para Title</b>	<b>Para. No.</b>
Pilot and CPG Caution and Warning Panels - Wiring Interconnect Diagram .....	9-334
Pilot Caution and Warning System - Maintenance Operational Check .....	9-335
Pilot Caution and Warning System - Wiring Interconnect Diagram .....	9-336
Pilot Circuit Breaker Panel, Removal, Installation Procedure .....	9-151
Pilot Edge-Lights - Maintenance Operational Check .....	9-115
Pilot Edge-Lights - Wiring Interconnect Diagram .....	9-116
Pilot Utility and Secondary Lights - Maintenance Operational Check .....	9-105
Pilot Utility and Secondary Lights - Wiring Interconnect Diagram .....	9-106
Pitot Anti-Ice - Maintenance Operational Check .....	12-56
Pitot Anti-Ice - Power Down .....	12-55
Pitot Anti-Ice - Power Up .....	12-54
Pitot Anti-Ice - Wiring Interconnect Diagram .....	12-57
Power Plants, Controls and Indicators .....	4-6
Power Plants, Electrical Component Location and Configuration (ECLC) Index .....	4-9
Power Plants, Equipment Characteristics, Capabilities, and Features .....	4-1
Power Plants, Equipment Configuration .....	4-4
Power Plants, Equipment Data .....	4-3
Power Plants, Location and Description of Major Components .....	4-2
Power Plants - Maintenance Operational Check (Engine 1) .....	4-12
Power Plants - Maintenance Operational Check (Engine 2) .....	4-13
Power Plants, Multiplex Read Codes .....	4-8
Power Plants - Power Down .....	4-11
Power Plants - Power Up .....	4-10
Power Plants, Safety, Care and Handling of Equipment .....	4-5
Power Plants, System Description .....	4-7
Power Plants - Wiring Interconnect Diagram .....	4-14
Pressure Refueling/Defueling - Maintenance Operational Check .....	10-76
Pressure Refueling/Defueling - Wiring Interconnect Diagram .....	10-77

**ALPHABETICAL INDEX**

<b>Para Title</b>	<b>Para. No.</b>
Pressurized Air System - Maintenance Operational Check .....	7-45
Pressurized Air System - Wiring Interconnect Diagram .....	7-46
Primary Hydraulic System - Maintenance Operational Check .....	7-10
Primary Hydraulic System - Wiring Interconnect Diagram .....	7-11

**Q**

**R**

Recommended Steps Prior to Aircraft Operations .....	5-18
Rotor Blades De-Ice - Maintenance Operational Check .....	12-62
Rotor Blades De-Ice - Wiring Interconnect Diagram .....	12-63
Rotors, Controls and Indicators .....	5-6
Rotors, Equipment Characteristics, Capabilities, and Features .....	5-1
Rotors, Equipment Configuration .....	5-4
Rotors, Equipment Data .....	5-3
Rotors, Flight Check and Adjustment Using AVA Equipment .....	5-21
Rotors, Ground Track and Adjustment Using AVA Equipment .....	5-19
Rotors, Initial Check and Adjustment Using AVA Equipment .....	5-20
Rotors, Isolating/Monitoring Other Vibrations Using AVA Equipment .....	5-24
Rotors, Location and Description of Major Components .....	5-2
Rotors, Main Rotor - Track and Balance Maintenance Using AVA Equipment .....	5-17
Rotors, Main Rotor - Track and Balance Troubleshooting Using AVA Equipment .....	5-22
Rotors, Multiplex Read Codes .....	5-8
Rotors, Safety, Care and Handling of Equipment .....	5-5
Rotors, System Description .....	5-7
Rotors, Tail Rotor Balance - Maintenance Operational Check Using AVA Equipment .....	5-23

**S**

Squat Switch System - Maintenance Operational Check .....	9-413
Squat Switch System - Wiring Interconnect Diagram .....	9-414
Stabilator - Maintenance Operational Check .....	11-88
Stabilator - Power Down, DASE/ .....	11-11
Stabilator - Power Up, DASE/ .....	11-10

## ALPHABETICAL INDEX

Para Title	Para. No.
Stabilator - Wiring Interconnect Diagram .....	11-89

### T

Tail Landing Gear - Maintenance Operational Check .....	3-11
■ Tail Rotor Balance - Maintenance Operational Check Using AVA .....	5-13
Torque Sharing System - Maintenance Operational Check .....	4-15
Torque Sharing System - Wiring Interconnect Diagram .....	4-16
■ Track and Balance Troubleshooting Using AVA Equipment, Main Rotor .....	5-22
■ Track and Balance Using AVA Equipment, Main Rotor .....	5-17

### U

Utility Hydraulic System - Maintenance Operational Check .....	7-20
Utility Hydraulic System - Wiring Interconnect Diagram .....	7-21
Utility Systems, Controls and Indicators .....	12-6
Utility Systems, Description .....	12-7
Utility Systems, Electrical Component Location and Configuration (ECLC) Index .....	12-9
Utility Systems, Equipment Characteristics, Capabilities, and Features .....	12-1
Utility Systems, Equipment Configuration .....	12-4
Utility Systems, Equipment Data .....	12-3
Utility Systems, Location and Description of Major Components .....	12-2
Utility Systems, Multiplex Read Codes .....	12-8
Utility Systems, Safety, Care and Handling of Equipment .....	12-5

### V

### W

Windshield Wipers - Maintenance Operational Check .....	12-87
Windshield Wipers - Power Down .....	12-86
Windshield Wipers - Power Up .....	12-85
Windshield Wipers - Wiring Interconnect Diagram .....	12-88
Wiring Interconnect Diagram (BUCS Activated), DASE - .....	11-28
Wiring Interconnect Diagram (Collective) (BUCS Deactivated), DASE - .....	11-27
Wiring Interconnect Diagram (Pitch) (BUCS Deactivated), DASE - .....	11-24



## ALPHABETICAL INDEX

<b>Para Title</b>	<b>Para. No.</b>
Wiring Interconnect Diagram (Roll) (BUCS Deactivated), DASE - .....	11-25
Wiring Interconnect Diagram (Yaw) (BUCS Deactivated), DASE - .....	11-26
Wiring Interconnect Diagram, AC Electrical Power Generation - .....	9-13
Wiring Interconnect Diagram, APU Fire Detection - .....	12-124
Wiring Interconnect Diagram, Anti-Collision Lights - .....	9-73
Wiring Interconnect Diagram, Audio Warning System - .....	9-398
Wiring Interconnect Diagram, Auxiliary Fuel System - .....	10-101
Wiring Interconnect Diagram, Auxiliary Power Unit - .....	15-13
Wiring Interconnect Diagram, Battery - .....	9-43
Wiring Interconnect Diagram, CPG Caution and Warning System - .....	9-667
Wiring Interconnect Diagram, CPG Edge-Lights - .....	9-135
Wiring Interconnect Diagram, CPG Utility and Secondary Lights - .....	9-111
Wiring Interconnect Diagram, Canopy Defog and Anti-Ice - .....	12-13
Wiring Interconnect Diagram, Circuit Breaker Edge-Light Panels - .....	9-329
Wiring Interconnect Diagram, DC Electrical Power Generation System - .....	9-24
Wiring Interconnect Diagram, Drive System - .....	6-14
Wiring Interconnect Diagram, Engine 1 Fire Detection - .....	12-100
Wiring Interconnect Diagram, Engine 2 Fire Detection - .....	12-113
Wiring Interconnect Diagram, Engine Instruments - .....	8-11
Wiring Interconnect Diagram, Engine anti-Ice - .....	12-26
Wiring Interconnect Diagram, Environmental Control System - .....	13-13
Wiring Interconnect Diagram, External Stores Elevation Control - .....	16-13
Wiring Interconnect Diagram, External Stores Jettison - .....	16-22
Wiring Interconnect Diagram, Fire Extinguishers - .....	12-134
Wiring Interconnect Diagram, Flight Instruments - .....	8-92
Wiring Interconnect Diagram, Force Trim - .....	11-13
Wiring Interconnect Diagram, Formation Lights - .....	9-65
Wiring Interconnect Diagram, Fuel Crossfeed/Boost System - .....	10-18

**ALPHABETICAL INDEX**

<b>Para Title</b>	<b>Para. No.</b>
Wiring Interconnect Diagram, Fuel Quantity Indication/Transfer - .....	10-49
Wiring Interconnect Diagram, Landing/Search Light - .....	9-83
Wiring Interconnect Diagram, Maintenance Lights - .....	9-101
Wiring Interconnect Diagram, Miscellaneous Instruments - .....	8-106
Wiring Interconnect Diagram, Navigation Lights - .....	9-58
Wiring Interconnect Diagram, Nitrogen Inerting System - .....	10-68
Wiring Interconnect Diagram, Pilot and CPG Caution and Warning Panels - .....	9-334
Wiring Interconnect Diagram, Pilot Caution and Warning System - .....	9-336
Wiring Interconnect Diagram, Pilot Edge-Lights - .....	9-116
Wiring Interconnect Diagram, Pilot Utility and Secondary Lights - .....	9-106
Wiring Interconnect Diagram, Pitot Anti-Ice - .....	12-57
Wiring Interconnect Diagram, Power Plants - .....	4-14
Wiring Interconnect Diagram, Pressure Refueling/Defueling - .....	10-77
Wiring Interconnect Diagram, Pressurized Air System - .....	7-45
Wiring Interconnect Diagram, Primary Hydraulic System - .....	7-10
Wiring Interconnect Diagram, Rotor Blades De-Ice - .....	12-63
Wiring Interconnect Diagram, Squat Switch System - .....	9-414
Wiring Interconnect Diagram, Stabilator - .....	11-89
Wiring Interconnect Diagram, Torque Sharing System - .....	4-16
Wiring Interconnect Diagram, Utility Hydraulic System - .....	7-21
Wiring Interconnect Diagram, Windshield Wipers - .....	12-88
Wiring Interconnect Diagram, Circuit Protection System (DC Essential Bus 3 - Pilot Station) - .....	9-236
Wiring Interconnect Diagram, External Power and Ground Service Utility Receptacle - .....	9-49

**X**

**Y**

**Z**

**By Order of the Secretary of the Army:**

**Official:**

GORDON R. SULLIVAN  
*General, United States Army*  
*Chief of Staff*

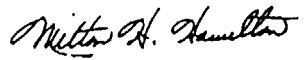
  
MILTON H. HAMILTON  
*Administrative Assistant to the*  
*Secretary of the Army*  
01687

**DISTRIBUTION:**

To be distributed in accordance with DA Form 12-31-E, block no. 3122, AVUM and AVIM maintenance requirements for TM 1-1520-238-T-8.



**THESE ARE THE INSTRUCTIONS FOR SENDING AN ELECTRONIC 2028**

The following format must be used if submitting an electronic 2028. The subject line must be exactly the same and all fields must be included; however only the following fields are mandatory: 1, 3, 4, 5, 6, 7, 8, 9, 10, 13, 15, 16, 17, and 27.

From: "Whomever" <whomever@avma27.army.mil>

To: ls-lp@redstone.army.mil

Subject: DA Form 2028

1. **From:** Joe Smith
2. Unit: Home
3. **Address:** 4300 Park
4. **City:** Hometown
5. **St:** MO
6. **Zip:** 77777
7. **Date Sent:** 19-Oct-93
8. **Pub no:** 55-2840-229-23
9. **Pub Title:** TM
10. **Publication Date:** 04-Jul-85
11. Change Number: 7
12. Submitter Rank: MSG
13. **Submitter Fname:** Joe
14. Submitter Mname: T
15. **Submitter Lname:** Smith
16. **Submitter Phone:** (123) 123-1234
17. **Problem:** 1
18. Page: 2
19. Paragraph: 3
20. Line: 4
21. NSN: 5
22. Reference: 6
23. Figure: 7
24. Table: 8
25. Item: 9
26. Total: 123
27. **Text:**

This is the text for the problem below line 27.



<b>RECOMMENDED CHANGES TO PUBLICATIONS AND BLANK FORMS</b> For use of the for, see AR 25-35; the proponent agency is ODISC4						Use Part II (reverse) for Repair Parts and Special Tool Lists (RPSTL) and Supply Catalogs/Supply Manuals (SC/SM).	<b>DATE</b> 8/30/02
<b>TO:</b> (Forward to proponent of the publication or form) (Include ZIP Code) Commander, U.S. Army Aviation and Missile Command Attn: AMSAM-MMC-MA-NP Redstone Arsenal, AL 35898						<b>FROM:</b> (Activity and location) (Include ZIP Code) SP4 John Doe F Troop 5 <sup>th</sup> Ca. 1 <sup>st</sup> Taining Bldg. Fort Knox, Kentucky 12345-6789	
<b>PART I - ALL PUBLICATIONS (EXCEPT RPSTL AND SC/SM) AND BLANK FORMS</b>							
PUBLICATION/FORM NUMBER TM 9-1005-43-24						DATE 16 Sep 2002	TITLE Organizational, Direct Support And General Support Maintenance Manual for Machine Gun, .50 Caliber M3P and M3P Machine Gun Electrical Test Set Used on Avenger Air Defense Weapon System
ITEM	PAGE	PARA-GRAPH	LINE	FIGURE NO.	TABLE	RECOMMENDED CHANGES AND REASON	
1	WP0005 PG 3		1			Test or Corrective Action column should identify a different WP number.	
<b>EXAMPLE</b>							
<i>*Reference to line numbers within the paragraph or subparagraph.</i>							
TYPED NAME, GRADE OR TITLE				TELEPHONE EXCHANGE/AUTOVON, PLUS EXTENTION		SIGNATURE	

<b>TO:</b> <i>(Forward direct to addressee listed in publication)</i> Commander, U.S. Army Aviation and Missile Command ATTN: AMSAM-MMC-MA-NP RedstoneArsenal, 35898	<b>FROM:</b> <i>(Activity and location) (Include ZIP Code)</i> MSG, Jane Q. Doe 1234 Any Street Nowhere Town, AL 34565	<b>DATE</b> 8/30/02
---	---	------------------------

**PART II - REPAIR PARTS AND SPECIAL TOOL LISTS AND SUPPLY CATALOGS/SUPPLY MANUALS**

PUBLICATION NUMBER	DATE	TITLE
--------------------	------	-------

PAGE NO.	COLM NO.	LINE NO.	NATIONAL STOCK NUMBER	REFERENCE NO.	FIGURE NO.	ITEM NO.	TOTAL NO. OF MAJOR ITEMS SUPPORTED	RECOMMENDED ACTION

**PART III - REMARKS** *(Any general remarks or recommendations, or suggestions for improvement of publications and blank forms. Additional blank sheets may be used if more space is needed.)*

**EXAMPLE**

TYPED NAME, GRADE OR TITLE	TELEPHONE EXCHANGE/AUTOVON, PLUS EXTENTION	SIGNATURE
----------------------------	--	-----------



<b>RECOMMENDED CHANGES TO PUBLICATIONS AND BLANK FORMS</b> For use of the for, see AR 25-35; the proponent agency is ODISC4						Use Part II ( <i>reverse</i> ) for Repair Parts and Special Tool Lists (RPSTL) and Supply Catalogs/Supply Manuals (SC/SM).	<b>DATE</b>
<b>TO:</b> ( <i>Forward to proponent of the publication or form</i> ) ( <i>Include ZIP Code</i> )						<b>FROM:</b> ( <i>Activity and location</i> ) ( <i>Include ZIP Code</i> )	
<b>PART I - ALL PUBLICATIONS (EXCEPT RPSTL AND SC/SM) AND BLANK FORMS</b>							
PUBLICATION/FORM NUMBER TM 1-1520-238-T-8					DATE 30 April 1992	TITLE Aviation Unit and Intermediate Troubleshooting Manual for Army Model AH-64A Helicopter	
ITEM	PAGE	PARA-GRAPH	LINE	FIGURE NO.	TABLE	RECOMMENDED CHANGES AND REASON	
<i>*Reference to line numbers within the paragraph or subparagraph.</i>							
TYPED NAME, GRADE OR TITLE				TELEPHONE EXCHANGE/AUTOVON, PLUS EXTENTION		SIGNATURE	

<b>TO:</b> <i>(Forward direct to addressee listed in publication)</i>	<b>FROM:</b> <i>(Activity and location) (Include ZIP Code)</i>	<b>DATE</b>
---	--	-------------

**PART II - REPAIR PARTS AND SPECIAL TOOL LISTS AND SUPPLY CATALOGS/SUPPLY MANUALS**

<b>PUBLICATION NUMBER</b> TM 1-1520-238-T-8	<b>DATE</b> 30 April 1992	<b>TITLE</b> Aviation Unit and Intermediate Troubleshooting Manual for Army Model AH-64A Helicopter
--	------------------------------	---

PAGE NO.	COLM NO.	LINE NO.	NATIONAL STOCK NUMBER	REFERENCE NO.	FIGURE NO.	ITEM NO.	TOTAL NO. OF MAJOR ITEMS SUPPORTED	RECOMMENDED ACTION

**PART III - REMARKS** *(Any general remarks or recommendations, or suggestions for improvement of publications and blank forms. Additional blank sheets may be used if more space is needed.)*

--

TYPED NAME, GRADE OR TITLE	TELEPHONE EXCHANGE/AUTOVON, PLUS EXTENTION	SIGNATURE
----------------------------	--	-----------

# The Metric System and Equivalents

## Linear Measure

1 centimeter = 10 millimeters = .39 inch  
 1 decimeter = 10 centimeters = 3.94 inches  
 1 meter = 10 decimeters = 39.37 inches  
 1 dekameter = 10 meters = 32.8 feet  
 1 hectometer = 10 dekameters = 328.08 feet  
 1 kilometer = 10 hectometers = 3,280.8 feet

## Weights

1 centigram = 10 milligrams = .15 grain  
 1 decigram = 10 centigrams = 1.54 grains  
 1 gram = 10 decigrams = .035 ounce  
 1 dekagram = 10 grams = .35 ounce  
 1 hectogram = 10 dekagrams = 3.52 ounces  
 1 kilogram = 10 hectograms = 2.2 pounds  
 1 quintal = 100 kilograms = 220.46 pounds  
 1 metric ton = 10 quintals = 1.1 short tons

## Liquid Measure

1 centiliter = 10 milliliters = .34 fl. ounces  
 1 deciliter = 10 centiliters = 3.38 fl. ounces  
 1 liter = 10 deciliters = 33.81 fl. ounces  
 1 dekaliter = 10 liters = 2.64 gallons  
 1 hectoliter = 10 dekaliters = 26.42 gallons  
 1 kiloliter = 10 hectoliters = 264.18 gallons

## Square Measure

1 sq. centimeter = 100 sq. millimeters = .155 sq. inch  
 1 sq. decimeter = 100 sq. centimeters = 15.5 sq. inches  
 1 sq. meter (centare) = 100 sq. decimeters = 10.76 sq. feet  
 1 sq. dekameter (are) = 100 sq. meters = 1,076.4 sq. feet  
 1 sq. hectometer (hectare) = 100 sq. dekameters = 2.47 acres  
 1 sq. kilometer = 100 sq. hectometers = .386 sq. mile

## Cubic Measure

1 cu. centimeter = 1000 cu. millimeters = .06 cu. inch  
 1 cu. decimeter = 1000 cu. centimeters = 61.02 cu. inches  
 1 cu. meter = 1000 cu. decimeters = 35.31 cu. feet

## Approximate Conversion Factors

To change	To	Multiply by	To change	To	Multiply by
inches	centimeters	2.540	ounce-inches	newton-meters	.007062
feet	meters	.305	centimeters	inches	.394
yards	meters	.914	meters	feet	3.280
miles	kilometers	1.609	meters	yards	1.094
square inches	square centimeters	6.452	kilometers	miles	.621
square feet	square meters	.093	square centimeters	square inches	.155
square yards	square meters	.836	square meters	square feet	10.764
square miles	square kilometers	2.590	square meters	square yards	1.196
acres	square hectometers	.405	square kilometers	square miles	.386
cubic feet	cubic meters	.028	square hectometers	acres	2.471
cubic yards	cubic meters	.765	cubic meters	cubic feet	35.315
fluid ounces	milliliters	29.573	cubic meters	cubic yards	1.308
pints	liters	.473	milliliters	fluid ounces	.034
quarts	liters	.946	liters	pints	2.113
gallons	liters	3.785	liters	quarts	1.057
ounces	grams	28.349	liters	gallons	.264
pounds	kilograms	.454	grams	ounces	.035
short tons	metric tons	.907	kilograms	pounds	2.205
pound-feet	newton-meters	1.356	metric tons	short tons	1.102
pound-inches	newton-meters	.11296			

## Temperature (Exact)

° F Fahrenheit temperature  $\frac{5}{9}$  (after subtracting 32) Celsius temperature ° C

